



AIRE ACONDICIONADO

Manual Técnico 2010

Instalación y Localización de Averías

Mr. SLIM

INVERTER S-SERIES**SEZ-KD25-35-50-60-71VA | SLZ-KA25-35-50VA |****SUZ-KA25-35-50-60-71VA**

Especificaciones	I16
Plano de dimensiones.....	I11
Esquemas Eléctricos.....	I15
Esquemas Frigoríficos	I21
Funciones	I26
Datos de flujo de aire.....	I27
Datos de instalaciones.....	I29

GAMA POWER INVERTER**PLA-RP-BA | PUHZ-RP35-50-60-71-100-125-140VKA | PEAD-RP-JA | PUHZ-RP100-125-140YKA | PEAD-RP-JA | PKA-RP-HAL | PKA-RP-KAL | PCA-RP-KA | PSA-RP-GA E**

Especificaciones	I32
Plano de dimensiones.....	I53
Esquemas Eléctricos.....	I73
Esquemas Frigoríficos	I87
Funciones	I100
Datos de instalaciones.....	I104

GAMA STANDARD INVERTER**PLA-RP-BA | PEAD-RP-JA | PKA-RP-HAL | PKA-RP-KAL PCA-RP-KA
PSA-RP-GA | SUZ- KA35-50-60-71VA | PUHZ-P100-125-140VKA**

Especificaciones	I106
Plano de dimensiones.....	I118
Esquemas Eléctricos.....	I139
Esquemas Frigoríficos	I151
Funciones	I159
Datos de instalaciones.....	I162

GAMA NO INVERTER

**PLA-RP-AA | PUH-P71-100VHA | PEAD-RP-EA | PUH-P71-100-125-140YHA |
 PEAD-RP-GA | PU-P71-100VHA | PKA-RP-GAL | PU-P71-100-125-140YHA |
 PKA-RP-FAL | PCA-RP-GA | PSA-RP-GA**

Especificaciones	I164
Plano de dimensiones.....	I178
Esquemas Eléctricos.....	I197
Esquemas Frigoríficos	I210
Funciones	I218
Datos de instalaciones	I220

DATOS DE FLUJO DE AIRE

**PLA-RP-AA | PEAD-RP-EA | PEAD-RP-GA | PKA-RP-GAL | PKA-RP-FAL
 PCA-RP-GA | PSA-RP-GA** I224

RESOLUCIÓN DE AVERÍAS..... I240

FUNCIONES	I825
Función de monitoreo de operación de la unidad exterior a través de la opcional PAC-Sk52	I826
Configuración de funciones	I834
Función de monitoreo de operación de las unidades a través del control PAR-21MAA	I840
Función de mantenimiento fácil a través del control PAR-21MAA	I850
ASISTENTE TÉCNICO SMS	I854
GARANTÍA / CONTACTO	I860
AGENDA	I862

INVERTER S-SERIES

CONDUCTOS

SEZ-KD25VA

SUZ-KA25/35/50/60/71VA

CASSETTE

SLZ-KA25/35/50VA

SUZ-KA25/35/50/60/71VA

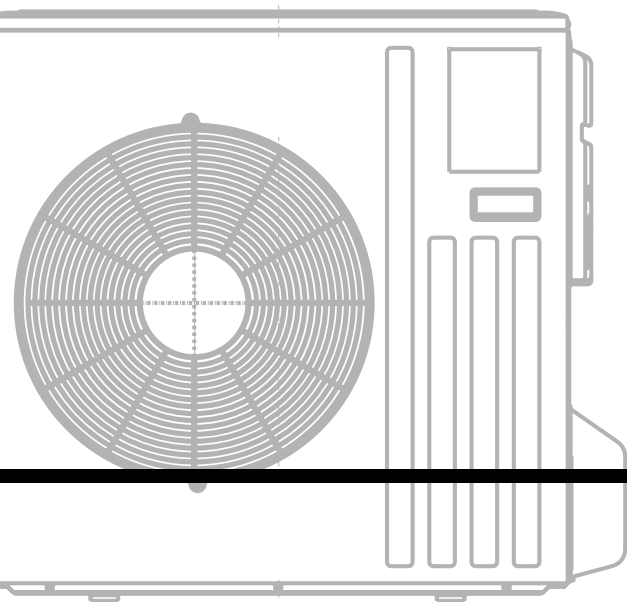

Model Name		SEZ-KD25VA(L)			SEZ-KD35VA(L)		
Capacity		Cooling	Heating		Cooling	Heating	
		kW	2.5	3.0	3.5	4.0	
Power source			230V (50Hz)		230V (50Hz)		
Power input	kW	0.04		0.04	0.05	0.05	
Current	A	0.39		0.39	0.46	0.46	
Temperature set range	Remote controller	C/F	19 to 30 (67 to 86)	17 to 28 (63 to 83)	19 to 30 (67 to 86)	17 to 28 (63 to 83)	
Airflow direction							
Fan	Type x Quantity		Sirocco fan x 2		Sirocco fan x 2		
	External static press	Pa	5-15-35-50		5-15-35-50		
	Motor type		DC brushless motor		DC brushless motor		
	Motor output	kW	0.096		0.096		
	Driving mechanism		Direct-driven		Direct-driven		
	Airflow rate(Low-Mid-High)	m ³ /min	5.5-7.0-9.0		7.0-9.0-11.0		
External finish							
			Galvanized		Galvanized		
External dimension							
H x W x D		mm	200 x 700 x 700		200 x 900 x 700		
		In.	7-7/8 x 27-9/16 x 27-9/16		7-7/8 x 35-7/16 x 27-9/16		
Net weight							
		kg	18		21		
Wiring							
	Min.size of wire	mm(in.)	1.6 (1/8)		1.6 (1/8)		
	Amperage of wire breaker	A	15		15		
Refrigerant piping diameter	Liquid	R410A	ø6.35 (ø1/4) Flare		ø6.35 (ø1/4) Flare		
	Gas	R410A	ø9.52 (ø3/8) Flare		ø9.52 (ø3/8) Flare		
Drain piping diameter		mm(in.)	O.D. 32 (1-9/32)		O.D. 32 (1-9/32)		
Noise level (Low-Mid-High) (measured in anechoic room)		dB<A>	23-26-30		23-28-33		
Insulation material							
Air filter			Polystyrene foam, Polyethylene foam, Urethane foam		Polystyrene foam, Polyethylene foam, Urethane foam		
Refrigerant control device			FP Honeycomb fabric (washable)		FP Honeycomb fabric (washable)		
Connectable outdoor unit							
			R410A SUZ-KA25VA(H)		R410A SUZ-KA35VA(H)		
Protection devices							
			Fuse (250V 6.3A)		Fuse (250V 6.3A)		
Heat exchanger							
			Cross fin (Aluminum fin and copper tube)		Cross fin (Aluminum fin and copper tube)		
Varistor							
			ERZV10D471		ERZV10D471		
Terminal block							
			To outdoor unit : 3P To wired remote controller : 2P		To outdoor unit : 3P To wired remote controller : 2P		
Power outlet							
		A	10		10		
Standard attachment							
	Document		Installation Manual, Instruction Book		Installation Manual, Instruction Book		
	Accessory	*3	Drain hose (flexible joint), Remote Controller		Drain hose (flexible joint), Remote Controller		
Optional parts							
			Drain lift-up mechanism (PAC-KE07DM-E)		Drain lift-up mechanism (PAC-KE07DM-E)		
Remark							
Note							
1.Cooling/Heating capacity indicates the maximum value at operation under the following condition. -<Cooling> Indoor: 27°C DB, 19°C WB, (81°F DB, / 66°F WB, Outdoor: 35°C DB, (95°F DB,) -<Heating> Indoor: 20°C DB, (68°F DB,) Outdoor: 7°C DB, / 6°C WB, (45°F DB, / 43°F WB,) Pipe length: 7.5m (24-9/16ft) Height difference: 0m (0ft)							
2.The external static pressure is set to 15 Pa at factory shipment.							
3.Wired Remote Controller for VA model , Wireless Remote Controller for VAL model							

Model Name		SEZ-KD50VA(L)		SEZ-KD60VA(L)	
Capacity		Cooling	Heating	Cooling	Heating
	kW	5.0	6.0	5.5	7.0
Power source		230V (50Hz)		230V (50Hz)	
Power input	kW	0.07	0.07	0.07	0.07
Current	A	0.63	0.63	0.63	0.63
Temperature set range Remote controller	°C (°F)	19 to 30 (67 to 86)	17 to 28 (63 to 83)	19 to 30 (67 to 86)	17 to 28 (63 to 83)
Airflow direction		-		-	
Fan	Type x Quantity	Sirocco fan x 3		Sirocco fan x 4	
	External static press	5-15-35-50		5-15-35-50	
	Motor type	DC brushless motor		DC brushless motor	
	Motor output	0.096		0.096	
	Driving mechanism	Direct-driven		Direct-driven	
Airflow rate(Low-Mid-High)	m ³ /min	10.0-12.5-15.0		12.0-15.0-18.0	
External finish		Galvanized		Galvanized	
External dimension	mm	200 x 900 x 700		200 x 1100 x 700	
H x W x D	in.	7-7/8 x 35-7/16 x 27-9/16		7-7/8 x 43-5/16 x 27-9/16	
Net weight	kg	23		27	
Wiring	Min.size of wire	mm(in.) 1.6 (1/8)		1.6 (1/8)	
	Amperage of wire breaker	A 15		15	
Refrigerant piping diameter	Liquid R410A	mm(in.) ø6.35 (ø1/4) Flare		ø6.35 (ø1/4) Flare	
	Gas R410A	mm(in.) ø12.7 (ø1/2) Flare		ø15.88 (ø5/8) Flare	
Drain piping diameter	mm(in.)	O.D. 32 (1-9/32)		O.D. 32 (1-9/32)	
Noise level (Low-Mid-High) (measured in anechoic room)	dB<A>	30-34-37		30-34-38	
Insulation material		Polystyrene foam, Polyethylene foam, Urethane foam		Polystyrene foam, Polyethylene foam, Urethane foam	
Air filter		PP Honeycomb fabric (washable)		PP Honeycomb fabric (washable)	
Refrigerant control device		-		-	
Connectable outdoor unit		R410A, SUZ-KA50VA		R410A, SUZ-KA60VA	
Protection devices		Fuse (250V 6.3A)		Fuse (250V 6.3A)	
Heat exchanger		Cross fin (Aluminum fin and copper tube)		Cross fin (Aluminum fin and copper tube)	
Varistor		ERZV10D471		ERZV10D471	
Terminal block		To outdoor unit : 3P To wired remote controller : 2P		To outdoor unit : 3P To wired remote controller : 2P	
Power outlet		20		20	
Standard attachment	Document	Installation Manual, Instruction Book		Installation Manual, Instruction Book	
	Accessory	*3	Drain hose (flexible joint), Remote Controller	Drain hose (flexible joint), Remote Controller	
Optional parts		Drain lift-up mechanism (PAC-KE07DM-E)		Drain lift-up mechanism (PAC-KE07DM-E)	
Remark					
Note		<p>1.Cooling/Heating capacity indicates the maximum value at operation under the following condition.</p> <p><Cooling> Indoor: 27 °C.D.B./19 °C.W.B. (81 °F.D.B. / 66 °F.W.B. Outdoor:35 °C.D.B. (95 °F.D.B.)</p> <p><Heating> Indoor:20 °C.D.B. (68 °F.D.B.) Outdoor:7 °C.D.B. / 6 °C.W.B. (45 °F.D.B. / 43 °F.W.B.)</p> <p>Pipe length: 7.5m (24-9/16ft) Height difference: 0m (0ft)</p> <p>2.The external static pressure is set to 15 Pa at factory shipment.</p> <p>3.Wired Remote Controller for VA model , Wireless Remote Controller for VAL model</p>			

Model Name		SEZ-KD71VA(L)	
Capacity		Cooling	Heating
		7.1	8.1
Power source		230V (50Hz)	
Power input		0.10	0.10
Current		0.84	0.84
Temperature set range Remote controller		C(F)	19 to 30 (67 to 86)
Airflow direction		17 to 28 (63 to 83)	
Fan		Sirocco fan x 4	
Type x Quantity		5-15-35-50	
External static press		Pa	
Motor type		DC brushless motor	
Motor output		kW	
Driving mechanism		0.096	
Airflow rate(Low-Mid-High)		Direct-driven	
		12.0-16.0-20.0	
External finish		Galvanized	
External dimension		mm	
H x W x D		230 x 1100 x 700	
		In.	
		7-7/8 x 43-5/16 x 27-9/16	
Net weight		kg	
		27	
Wiring		mm(in.)	
Min.size of wire		1.6 (1/8)	
Amperage of wire breaker		A	
		15	
Refrigerant piping diameter		mm(in.)	
Liquid R410A		ø9.52 (ø3/8) Flare	
Gas R410A		ø15.88 (ø5/8) Flare	
Drain piping diameter		mm(in.)	
		O.D. 32 (1-9/32)	
Noise level (Low-Mid-High) (measured in anechoic room)		dB<A>	
		30-35-40	
Insulation material		Polystyrene foam, Polyethylene foam, Urethane foam	
Air filter		PP Honeycomb fabric (washable)	
Refrigerant control device		-	
Connectable outdoor unit		R410A SUZ-KA71VA	
Protection devices		Fuse (250V 6.3A)	
Heat exchanger		Cross fin (Aluminum fin and copper tube)	
Varistor		ERZV10D471	
Terminal block		To outdoor unit : 3P To wired remote controller : 2P	
Power outlet		A	
		20	
Standard attachment		Document	
Accessory		*3 Installation Manual, Instruction Book	
Optional parts		Drain hose (flexible joint), Remote Controller	
Remark		Drain lift-up mechanism (PAC-KE07DM-E)	
Note		<p>1.Cooling/Heating capacity indicates the maximum value at operation under the following condition.</p> <p><Cooling> Indoor: 27 C.D.B./19° C.W.B. (81° F.D.B. / 66° F.W.B. Outdoor: 35° C.D.B. (95° F.D.B.)</p> <p><Heating> Indoor: 20 C.D.B. (68° F.D.B.) Outdoor: 7° C.D.B. / 6° C.W.B. (45° F.D.B. / 43° F.W.B.)</p> <p>Pipe length: 7.5m (24-9/16ft) Height difference: 0m (0ft)</p> <p>2.The external static pressure is set to 15 Pa at factory shipment.</p> <p>3.Wired Remote Controller for VA model , Wireless Remote Controller for VAL model</p>	

Modelo interior			SLZ-KA25VAL.TH SLZ-KA25VA.TH		SLZ-KA35VAL.TH SLZ-KA35VA.TH		SLZ-KA50VAL.TH SLZ-KA50VA.TH	
Función			Refrigeración	Calefacción	Refrigeración	Calefacción	Refrigeración	Calefacción
Suministro de energía			Monofásico 230V, 50Hz		Monofásico 230V, 50Hz		Monofásico 230V, 50Hz	
Capacidad	Circulación de aire (Alto/Medio/Bajo)	K/h	600/540/480		660/540/480		660/540/480	
Información eléctrica	Consumo	A	10		10		20	
	Corriente *1	A	0.35		0.40		0.65	
	Potencia consumida	W	75		85		85	
	Calefactor para evitar condensación	(kW)	0.014		0.014		0.014	
	Factor de energía *1	%	90	93	94	94	97	97
	Corriente del motor del ventilador	*1 A	0.19		0.26		0.27	
Motor del ventilador	Modelo		PK6V15-LD		PK6V20-LL		PK6V20-LM	
	Resistencia devanada (a20:)	Ω	BlANCo-NeGRo : 407 NeGRo-aZUL : 86 aZUL-aMaRILLo : 30 MaRRóN-RoJo : 165		BlANCo-NeGRo : 393 NeGRo-aZUL : 164 aZUL-aMaRILLo : 47 MaRRóN-RoJo : 319		BlANCo-NeGRo : 325 NeGRo-aZUL : 143 aZUL-aMaRILLo : 47 MaRRóN-RoJo : 309	
Dimensiones	Ancho	mm(in)	UNIDAD : 570(22-7/16)		UNIDAD : 570(22-7/16)		PANEL : 650(25-9/16)	
	Alto	mm(in)	UNIDAD : 208(8-3/16)		UNIDAD : 208(8-3/16)		PANEL : 20(13/16)	
	Profundidad	mm(in)	UNIDAD : 570(22-7/16)		UNIDAD : 570(22-7/16)		PANEL : 650(25-9/16)	
	Peso	kg	UNIDAD : 16.5		UNIDAD : 16.5		PANEL : 3	
Observaciones especiales	Dirección del aire		4		4		4	
	Nivel de sonido(Alto/Medio/Bajo)	dB(A)	37/31/28		38/33/29		39/34/30	
	Velocidad Ventilador(Alto/Medio/Bajo)	rpm	650/530/480		690/570/510		710/590/530	
	Regulador de velocidad del ventilador		3		3		3	
	Termistor TH1(a25°C)	k Ω	10		10		10	
	Termistor TH2(a25°C)	k Ω	10		10		10	
	Termistor TH5(a25°C)	k Ω	10		10		10	

NOTA : Las condiciones de prueba se basan en las normas ISO 5151

Refrigeración : Interior B.S. 27°C B.H. 19°C

Exterior B.S. 35°C B.H. 24°C

Calefacción : Interior B.S. 20°C B.H. 15°C

Exterior B.S. 7°C B.H. 6°C

Longitud de tubería refrigerante (unidireccional): 5m

*1 Medidos bajo frecuencia de operación nominal.

Especificaciones y condiciones de evaluación de las piezas eléctricas principales

UNIDAD INTERIOR

Item	Modelo	SLZ-KA25VAL.TH	SLZ-KA35VAL.TH	SLZ-KA50VAL.TH
		SLZ-KA25VA.TH	SLZ-KA35VA.TH	SLZ-KA50VA.TH
Capacitor del ventilador interior (C1)		1.5+ 440V		
Fusible (FUSIBLE)		250V 6.3A		
Motor de aleta (MV)		MSBPC20 12V 250"		
Bloque terminal (TB)		A UNIDAD EXTERIOR : 3P A CONTROL REMOTO ALAMBRICO: 2P (SLZ-KA25/35/50VA.TH)		
Fusible térmico del motor del ventilador interior		145: i 2:		
Calefactor con Cable (H2)		240V CA 15W		

Specifications and rating conditions of main electric parts

SUZ-KA25VA.TH SUZ-KA25VAH.TH

SUZ-KA35VA.TH SUZ-KA35VAH.TH

Item	Model	SUZ-KA25VA.TH	SUZ-KA25VAH.TH	SUZ-KA35VA.TH	SUZ-KA35VAH.TH
Current transformer	(CT)	ETA19Z59BZ			
Current transformer	(CT761, CT781)	ETQ19Z71AY			
Smoothing capacitor	(C63A, C63B, C63C)	620+ 420V			
Diode module	(DB61, DB65)	D25XB60			
Fuse	(F61)	250V 20A			
Fuse	(F71, F801, F901)	250V 3.15A			
Defrost heater	(H)	—	230V 130W	—	230V 130W
Intelligent power module	(IPM)	PS21244-A-203			
Expansion valve coil	(LEV)	CAD-MD12ME 12VDC			
Reactor	(L61)	10A 23.0mH			
Current-detecting resistor	(R61)	45m" 5W (1 element)		50m" 5W (2 elements)	
Current-detecting resistor	(R831)	25m" 5W			
Current-limiting resistor	(R64A, R64B)	5.1" 5W			
Terminal block	(TB1, TB2)	3P			
Relay	(X63)	G5NB-1a			
Relay	(X64)	G4A-1A-PS			
Relay	(X66)	—	G5NB-1a	—	G5NB-1a
R.V. coil	(21S4)	STF-01AJ503			
Heater protector	(26H)	—	Open 45:	—	Open 45:

SUZ-KA50VA.TH

SUZ-KA60VA.TH

SUZ-KA71VA.TH

Item	Model	SUZ-KA50VA.TH	SUZ-KA60VA.TH	SUZ-KA71VA.TH
Smoothing capacitor	(CB1,2,3)	560+ 450V		
Current transformer	(CT1,2)	ETQ19Z68AY		
Current transformer	(CT61)	ETQ19Z53AY		
Fuse	(F64)	250V 2A		
Fuse	(F801)	250V 3.15A		
Fuse	(F911)	250V 1A		
Intelligent power module	(HC930)	PS21661-RZ		
High pressure switch	(HPS)	—		ACB-DB156
Intelligent power module	(IPM)	PS21244-A		
Reactor	(L)	340μH 20A		
Expansion valve coil	(LEV)	CAM-MD12ME		
Power factor controller	(PFC)	PSS1259-A		
Resistor	(R64A,B)	10" 10W		
Resistor	(R937A,B)	1.1" 2W 2%		
Resistor	(RS1-4)	0.04" 7W		
Solenoid coil relay	(SSR61)	TLP3506		
Terminal block	(TB1)	3P		
Terminal block	(TB2)	3P		
Relay	(X64)	G4A		
R.V. coil	(21S4)	LD30013		

SUZ-KA25VA.TH SUZ-KA25VAH.TH
 SUZ-KA35VA.TH SUZ-KA35VAH.TH

Unit: mm

OUTDOOR UNIT

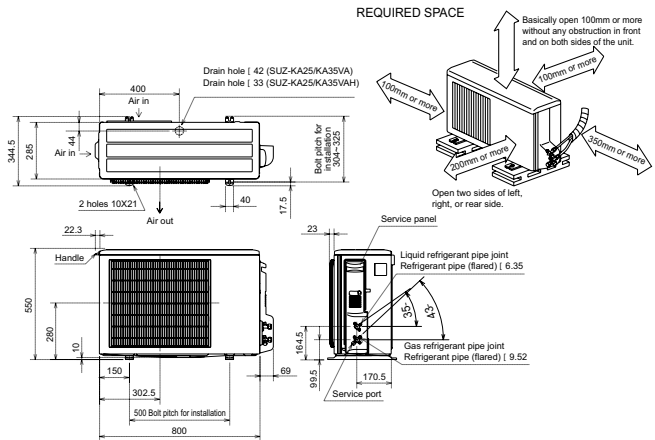

SUZ-KA50VA
 SUZ-KA60VA
 SUZ-KA71VA

Unit: mm

REQUIRED SPACE

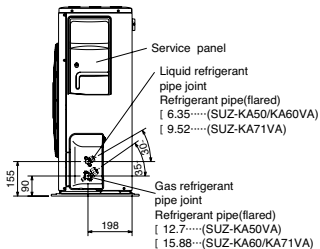
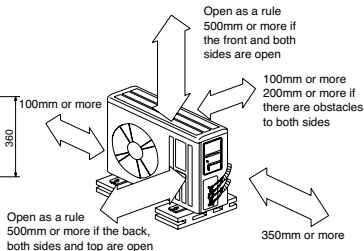
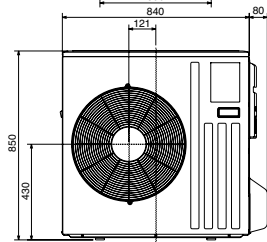
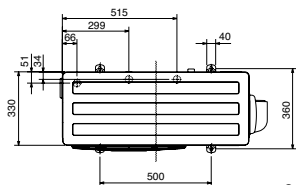

SEZ-KD25VA(L).TH
 SEZ-KD35VA(L).TH
 SEZ-KD50VA(L).TH
 SEZ-KD60VA(L).TH
 SEZ-KD71VA(L).TH

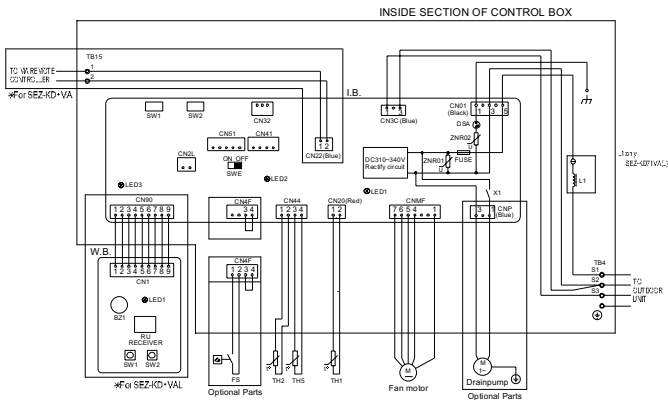

SYMBOL EXPLANATION

SYMBOL	NAME	SYMBOL	NAME
I.B.	INDOOR CONTROLLER BOARD	W.B.	WIRELESS REMOTE CONTROLLER BOARD
FUSE	FUSE AC250V 6.3A	RU	RECEIVING UNIT
ZNR01.02	VARISTOR	BZ1	BUZZER
DSA	ARRESTER	LED1	LED (RUN INDICATOR)
X1	AUX. RELAY	SW1	SWITCH (HEATING ON/OFF)
CN2L	CONNECTOR (LOSSNAY)	SW2	SWITCH (COOLING ON/OFF)
CN32	CONNECTOR (REMOTE SWITCH)	TH1	INTAKE AIR TEMP. THERMISTOR
CN41	CONNECTOR (HA TERMINAL-A)	TH2	PIPE TEMP. THERMISTOR/LIQUID
CN51	CONNECTOR (CENTRALLY CONTROL)	TH5	COND. EVA. TEMP. THERMISTOR
LED1	POWER SUPPLY (I.B.)	L1	AC REACTOR(POWER FACTOR IMPROVEMENT)
LED2	POWER SUPPLY (I.B.)	FS	FLOAT SWITCH
LED3	TRANSMISSION(INDOOR-OUTDOOR)	TB4	TERMINAL BLOCK (INDOOR/OUTDOOR CONNECTING LINE)
SW1	SWITCH (FOR MODE SELECTION)	TB15	TERMINAL BLOCK (REMOTE CONTROLLER TRANSMISSION LINE)
SW2	SWITCH (FOR CAPACITY CODE)		
SWE	CONNECTOR (EMERGENCY OPERATION)		

NOTE)1. Since the outdoor side electric wiring may change be sure to check the outdoor unit electric wiring for servicing.
 2. Indoor and outdoor connecting wires are made with polarities, make wiring matching terminal numbers(S1,S2,S3).
 3. Symbols used in wiring diagram above are,
 ⊕:Connector, ⊙:Terminal Block.

SLZ-KA25VAL.TH SLZ-KA25VA.TH SLZ-KA35VAL.TH SLZ-KA35VA.TH SLZ-KA50VAL.TH SLZ-KA50VA.TH

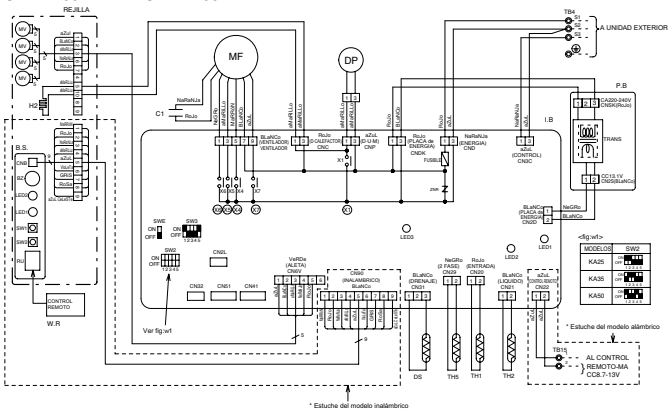

(LEYENDA)

SÍMBOLO	NOMBRE	SÍMBOLO	NOMBRE
P.B	PLACA DE ENERGIA INTERIOR	W.B	PLACA DE CONTROL REMOTO INALAMBICO
I.B	PLACA DE CONTROL INTERIOR	RU	UNIDAD RECEPTORA
CN2L	CONECTOR(LOSSNAY)	BZ	ZUMBADOR
CN32	CONECTOR(INTERRUPTOR REMOTO)	LED1	LED(INDICADOR de FUNCIONAMIENTO)
CN41	CONECTOR(HA TERMINAL-A)	LED2	LED(AJUSTE CALIENTE)
CN51	CONTROLADO CENTRALMENTE	SW1	INTERRUPTOR(CALEFACCION ENCENDIDO/APAGADO)
FUSE	FUSIBLE(T6.3AL250V)	SW2	INTERRUPTOR(REFRIGERACION ENCENDIDO/APAGADO)
LED1	SUMINISTRO DE ENERGIA(I.B)	C1	CAPACITOR(MOTOR del VENTILADOR)
LED2	SUMINISTRO DE ENERGIA(I.B)	DP	MAQUINA DE DRENAJE
LED3	TRANSMISION(INTERIOR-EXTERIOR)	DS	SENSOR DE DRENAJE
SW2	INTERRUPTOR(CODIGO DE CAPACIDAD)	H2	CALEFACTOR para EVITAR CONDENSACION
SW3	INTERRUPTOR(SELECCION DE MODO)	MF	MOTOR del VENTILADOR
SWE	INTERRUPTOR(OPERACION DE EMERGENCIA)	MV	MOTOR DE ALETA
X1	BOMBA de DRENAJE/CALEFACTOR para EVITAR CONDENSACION	TB4	BLOQUE TERMINAL(LINEA CONECTORA INTERIOR/EXTERIOR)
X4	RELAY(MOTOR del VENTILADOR LL)	TB15	BLOQUE TERMINAL(LINEA DE TRANSMISION DEL CONTROL REMOTO)
X5	RELAY(MOTOR del VENTILADOR Bajo)	TH1	TERMISTOR de TEMP AMBIENTE (0°C/15kΩ,25°C/5.4kΩ DETECT)
X6	RELAY(MOTOR del VENTILADOR Alto)	TH2	TERMISTOR de TEMP. de TUBERIA/LIQUIDO (0°C/15kΩ,25°C/5.4kΩ DETECT)
X7	RELAY(MOTOR del VENTILADOR Medio)	TH5	TERMISTOR de TEMP. del COND./EVA. (0°C/15kΩ,25°C/5.4kΩ DETECT)
ZNR	VARISTOR		

NOTES: 1.Como el cableado electrónico del lado exterior puede cambiar, asegurarse de controlar este cableado para su mantenimiento.

2.Los cables conectores de interior y exterior están hechos con polaridades, hacer que el cableado coincida en los números de los terminales(S1 S2.S3).

3.Los símbolos usados en el diagrama de cableado más arriba son: □:Conector, ●:Terminal (bloque).

w Para detalles de cómo operar el autodiagnóstico ver los manuales técnicos, etc.

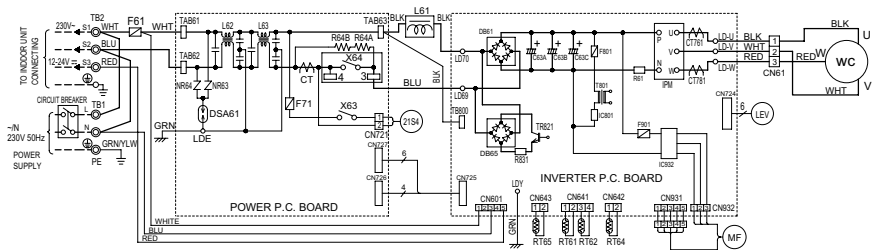

SYMBOL	NAME	SYMBOL	NAME	SYMBOL	NAME
CT,CT781,CT781	CURRENT TRANSFORMER	L61	REACTOR	R61,R831	CURRENT-DETECTING RESISTOR
CB3A,CB3B,CB3C	SMOOTHING CAPACITOR	L62,L63	CMC COIL	R64A,R64B	CURRENT-LIMITING RESISTOR
DB61,DB65	DIODE MODULE	MC	COMPRESSOR	TB1,TB2	TERMINAL BLOCK
DSA61	SURGE ABSORBER	MF	OUTDOOR FAN MOTOR	TR821	SWITCHING POWER TRANSISTOR
F61	FUSE (T20AL250V)	NR63,NR64	VARISTOR	T801	TRANSFORMER
F71	FUSE (T3.15AL250V)	RT61	DEFROST THERMISTOR	X63,X64	RELAY
F801,F901	FUSE (T3.15AL250V)	RT62	DISCHARGE TEMPERATURE THERMISTOR	21S4	R.V. COIL
IC801	INTELLIGENT POWER DEVICE	RT64	FIN TEMPERATURE THERMISTOR	LEV	EXPANSION VALVE COIL
IPM,IC932	INTELLIGENT POWER MODULE	RT65	AMBIENT TEMPERATURE THERMISTOR		

- NOTE:1. About the indoor side electric wiring refer to the indoor unit electric wiring diagram for servicing.
2. Use copper conductors only. (For field wiring)
3. Symbols below indicate.
○: Terminal block, □: Connector

SUZ-KA25VAH.TH
SUZ-KA35VAH.TH
OUTDOOR UNIT

MODELS WIRING DIAGRAM

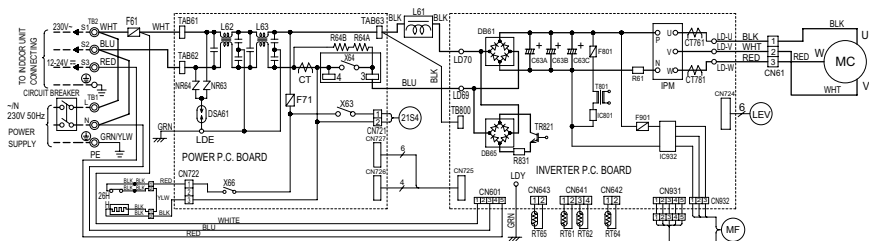

SYMBOL	NAME	SYMBOL	NAME	SYMBOL	NAME
CT,CT781,CT781	CURRENT TRANSFORMER	L61	REACTOR	R64A,R64B	CURRENT-LIMITING RESISTOR
C63A,C63B,C63C	SMOOTHING CAPACITOR	L62,L63	CMC COIL	TB1,TB2	TERMINAL BLOCK
DB61,DB65	DIODE MODULE	MC	COMPRESSOR	TR821	SWITCHING POWER TRANSISTOR
DSA61	SURGE ABSORBER	MF	OUTDOOR FAN MOTOR	T801	TRANSFORMER
F61	FUSE (T20AL250V)	NR63,NR64	VARIATOR	X63,X64,X66	RELAY
F71	FUSE (T3.15AL250V)	RT61	DEFROST THERMISTOR	21S4	R.V. COIL
F801,F901	FUSE (T3.15AL250V)	RT62	DISCHARGE TEMPERATURE THERMISTOR	H	DEFROST HEATER
IC801	INTELLIGENT POWER DEVICE	RT64	FIN TEMPERATURE THERMISTOR	26H	HEATER PROTECTOR
IPM,IC932	INTELLIGENT POWER MODULE	RT65	AMBIENT TEMPERATURE THERMISTOR		
LEV	EXPANSION VALVE COIL	R61,R831	CURRENT-DETECTING RESISTOR		

- NOTE:1. About the indoor side electric wiring refer to the indoor unit electric wiring diagram for servicing.
2. Use copper conductors only. (For field wiring)
3. Symbols below indicate.
○ Terminal block, □ Connector

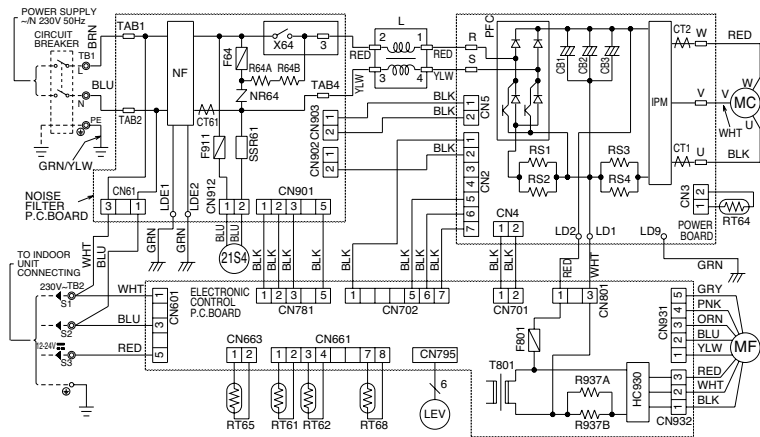

SYMBOL	NAME	SYMBOL	NAME	SYMBOL	NAME
CB1-3	SMOOTHING CAPACITOR	MC	COMPRESSOR	RT64	FIN TEMPERATURE THERMISTOR
CT1, 2	CURRENT TRANSFORMER	MF	OUTDOOR FAN MOTOR	RT65	AMBIENT TEMPERATURE THERMISTOR
CT61	CURRENT TRANSFORMER	NF	NOISE FILTER	RT68	OUTDOOR HEAT EXCHANGER TEMPERATURE THERMISTOR
F64	FUSE (T2AL 250V)	NR64	VARIATOR	T801	SOLENOID COIL RELAY
F801	FUSE (T3.15AL 250V)	PFC	POWER FACTOR CONTROLLER	T81	TRANSFORMER
F911	FUSE (T1AL 250V)	R64A,B	RESISTOR	TB01	TERMINAL BLOCK
HC930	INTELLIGENT POWER MODULE	R937A,B	RESISTOR	TB2	TERMINAL BLOCK
IPM	INTELLIGENT POWER MODULE	RS1-4	RESISTOR	TB2	TERMINAL BLOCK
L	REACTOR	RT61	DEFROST THERMISTOR	X64	RELAY
LEV	EXPANSION VALVE COIL	RT62	DISCHARGE TEMPERATURE THERMISTOR	X64	RELAY
				21S4	R.V. COIL

- NOTES: 1.About the indoor side electric wiring refer to the indoor unit electric wiring diagram for servicing.
2.Use copper conductors only (for field wiring).
3.Symbols below indicate.
●:Terminal block □:Connector

SUZ-KA71VA

MODEL WIRING DIAGRAM

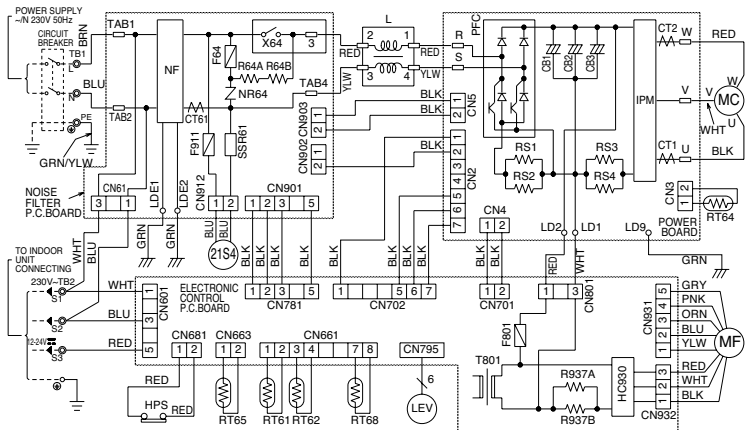

SYMBOL	NAME	SYMBOL	NAME	SYMBOL	NAME
CB1-3	SMOOTHING CAPACITOR	MC	COMPRESSOR	RT65	AMBIENT TEMPERATURE THERMISTOR
CT1, 2	CURRENT TRANSFORMER	MF	OUTDOOR FAN MOTOR	RT68	OUTDOOR HEAT EXCHANGER TEMPERATURE THERMISTOR
CT61	CURRENT TRANSFORMER	NF	NOISE FILTER	RT68	TEMPERATURE THERMISTOR
F64	FUSE (T2AL 250V)	NR64	VARIATOR	SSR61	SOLENOID COIL RELAY
F801	FUSE (T3.15AL 250V)	PFC	POWER FACTOR CONTROLLER	T801	TRANSFORMER
F911	FUSE (T1AL 250V)	R64A,B	RESISTOR	TB1	TERMINAL BLOCK
HC930	INTELLIGENT POWER MODULE	R937A, B	RESISTOR	TB2	TERMINAL BLOCK
HPS	HIGH PRESSURE SWITCH	RS1-4	RESISTOR	X64	RELAY
IPM	INTELLIGENT POWER MODULE	RT61	DEFROST THERMISTOR	21S4	R.V. COIL
L	REACTOR	RT62	DISCHARGE TEMPERATURE THERMISTOR		
LEV	EXPANSION VALVE COIL	RT64	FIN TEMPERATURE THERMISTOR		

- NOTES: 1.About the indoor side electric wiring refer to the indoor unit electric wiring diagram for servicing.
 2.Use copper conductors only (for field wiring).
 3.Symbols below indicate.
 ●:Terminal block □:Connector

SEZ-KD25VA(L).TH
 SEZ-KD35VA(L).TH
 SEZ-KD50VA(L).TH
 SEZ-KD60VA(L).TH
 SEZ-KD71VA(L).TH

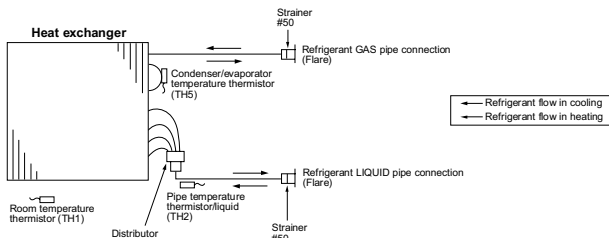

SLZ-KA25VAL.TH SLZ-KA25VA.TH
 SLZ-KA35VAL.TH SLZ-KA35VA.TH
 SLZ-KA50VAL.TH SLZ-KA50VA.TH

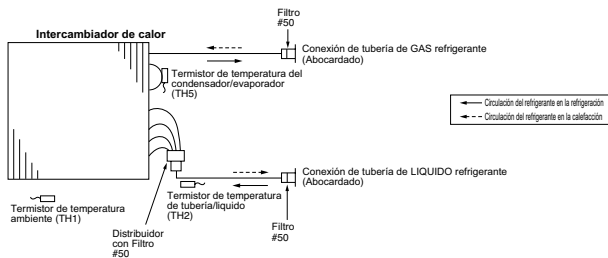

SUZ-KA25VA.TH
SUZ-KA25VAH.TH
OUTDOOR UNIT

Unit:mm

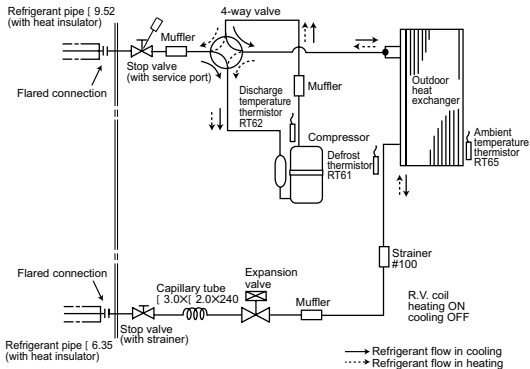

SUZ-KA35VA.TH
SUZ-KA35VAH.TH
OUTDOOR UNIT

Unit:mm

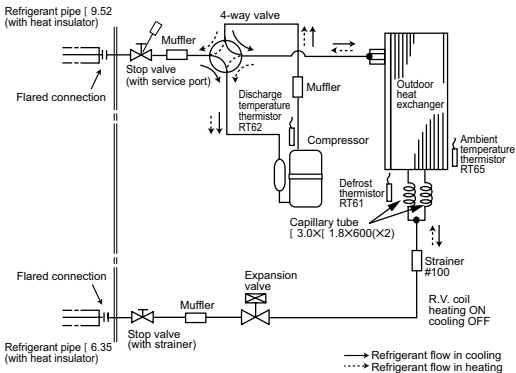

SUZ-KA50VA
SUZ-KA60VA

Unit:mm

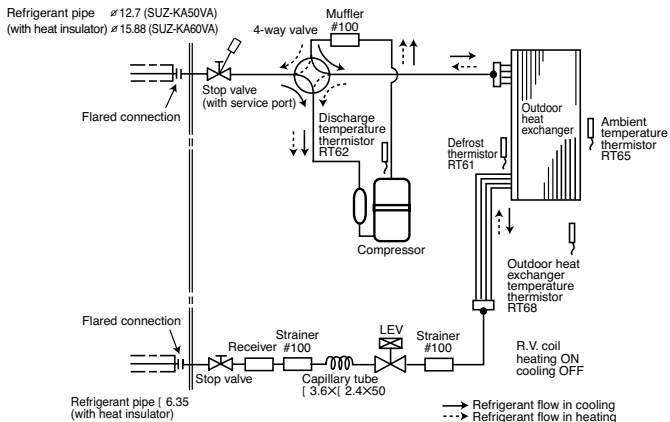

SUZ-KA71VA

Unit:mm

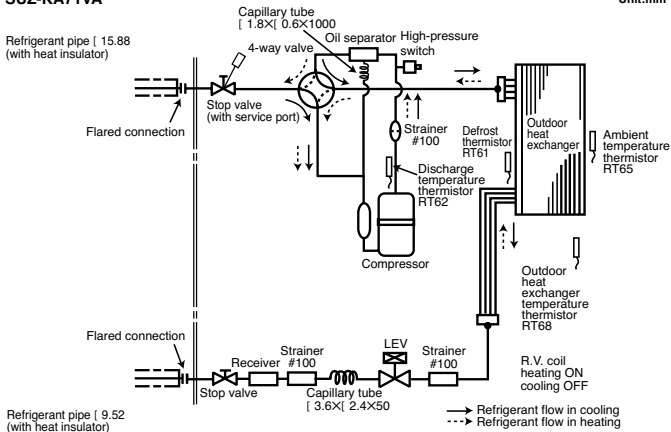

**SUZ-KA25VA.TH SUZ-KA25VAH.TH
SUZ-KA35VA.TH SUZ-KA35VAH.TH**

MAX. REFRIGERANT PIPING LENGTH

Models	Refrigerant piping Max. length : m A	Piping size O.D : mm	
		Gas	Liquid
SUZ-KA25VA.TH SUZ-KA35VA.TH SUZ-KA25VAH.TH SUZ-KA35VAH.TH	20	9.52	6.35

MAX. HEIGHT DIFFERENCE

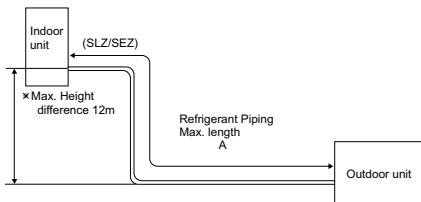

*Height difference should be within 12m regardless of which unit, indoor or outdoor position is high.

ADDITIONAL REFRIGERANT CHARGE (R410A:g)

Models	Outdoor unit precharged	Refrigerant piping length (one way)											
		5m	6m	7m	8m	9m	10m	11m	12m	13m	14m	15m	20m
SUZ-KA25VA.TH SUZ-KA25VAH.TH	900	0	0	0	90	120	150	180	210	240	270	300	450
SUZ-KA35VA.TH SUZ-KA35VAH.TH	1,050	0	0	0	90	120	150	180	210	240	270	300	450

Calculation : $Xg=30g/mo(\text{Refrigerant piping length}(m) - 5)$

SUZ-KA50VA
 SUZ-KA60VA
 SUZ-KA71VA

MAX. REFRIGERANT PIPING LENGTH

Model	Refrigerant piping Max. length : m A	Piping size O.D : mm	
		Gas	Liquid
SUZ-KA50VA	30	12.7	6.35
SUZ-KA60VA		15.88	
SUZ-KA71VA			9.52

MAX. HEIGHT DIFFERENCE

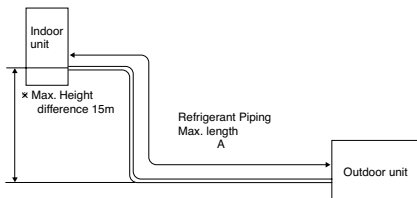

* Height difference should be within 15m regardless of which unit, indoor or outdoor position is high.

ADDITIONAL REFRIGERANT CHARGE(R410A : g)

Model	Outdoor unit precharged	Refrigerant piping length (one way)					
		7m	10m	15m	20m	25m	30m
SUZ-KA50VA	1,600	0	60	160	260	360	460
SUZ-KA60VA	1,800	0	60	160	260	360	460

Calculation : $X_g = 20g/m \times (\text{Refrigerant piping length (m)} - 7)$

Model	Outdoor unit precharged	Refrigerant piping length (one way)					
		7m	10m	15m	20m	25m	30m
SUZ-KA71VA	2,000	0	165	440	715	990	1,265

Calculation : $X_g = 55g/m \times (\text{Refrigerant piping length (m)} - 7)$

CONFIGURACION SW3 SEZ/SLZ

SW3	FUNCION	OFF	ON
SW3-1	AUTO.RESTART	OFF	ON
SW3-2	4 GRADOS	HABILITADO	NO HABILITADO
SW3-3	VELOCIDAD CUANDO HEAT OFF	EXTRA LOW	STOP
SW3-4	-	-	-
SW3-5	FUNCIONES DE SW3	NO HABILITADAS	HABILITADAS

7-1. Entrada de aire puro (Ubicación para la instalación)

Al momento de instalación, usar los orificios de conducto (aislados) ubicados en las posiciones que se muestran en el siguiente diagrama, como y cuando se lo requiera.

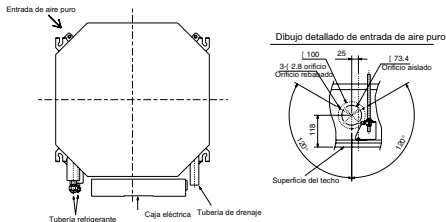

7-2. Características de cantidad de entrada de aire puro & presión estática

SLZ-KA25VAL.TH SLZ-KA25VA.TH
 SLZ-KA35VAL.TH SLZ-KA35VA.TH
 SLZ-KA50VAL.TH SLZ-KA50VA.TH

Entrada de aire en la unidad

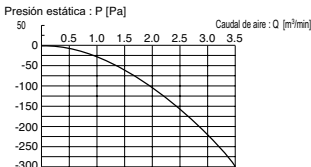

NOTA: La cantidad de entrada de aire puro debería ser del 20% o menos de la cantidad de aire total para evitar gotas de humedad.

Cómo leer las curvas

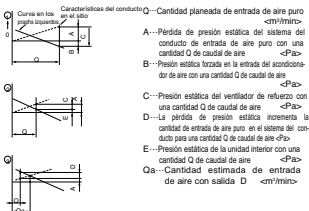

7-3. Método de operación de interbloqueo con ventilador de conducto (Ventilador de refuerzo)

- Cada vez que la unidad interior está funcionando, funciona el ventilador de conducto.

- (1) Conectar el adaptador del control remoto múltiple opcional (PAC-SA88HA-E) al conector CN51 en la placa del control interior.
- (2) Hacer funcionar el relé después de conectar el relé de 12V CC entre los cables conectores Amarillo y Naranja.

Usar un relé por debajo de 1W.

MB: Relé de energía del interruptor electromagnético para el ventilador de conducto.

X: Relé auxiliar (12V CC LY-1F)

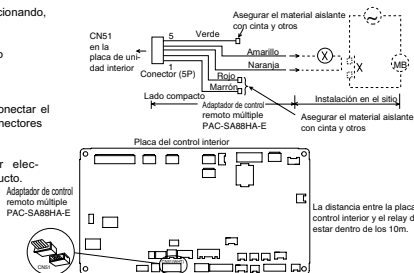

La distancia entre la placa del control interior y el relé debe estar dentro de los 10m.

7-4. Cómo fijar la aleta horizontal

La aleta horizontal de cada salida de aire puede fijarse de acuerdo al ambiente en que se instala.

Procedimiento de ajuste

- 1) Apagar el suministro principal de energía (Apagar el disyuntor).
- 2) Desconectar el conector del motor de aleta en la dirección de la flecha presionando el botón de apertura como se muestra en la figura abajo.

La electricidad se aísla en el conector que está desconectado con la cinta aisladora.

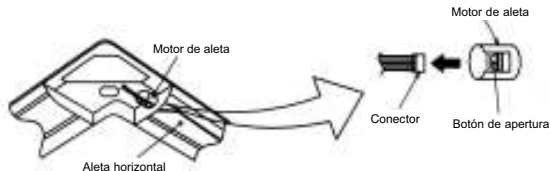

- 3) Colocar la aleta vertical de salida de aire, que se fija manualmente con suavidad, dentro del rango que se indica en la tabla de abajo.

Medida de posición
standard de la rejilla

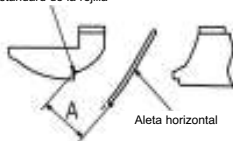

<Rango fijado>

Norma de posición horizontal	Nivel 30° (Min.)	Hacia abajo 45°	Hacia abajo 55°	Hacia abajo 70° (Max.)
Dimensión A (mm)	21	25	28	30

w La dimensión se puede ajustar arbitrariamente entre 21 mm y 30 mm.

Precaución	No ajustar la dimensión fuera de este rango.
	El ajuste erróneo puede producir gotas de humedad, manchas en el techo o un mal funcionamiento de la unidad.

SPLIT CASSETTE

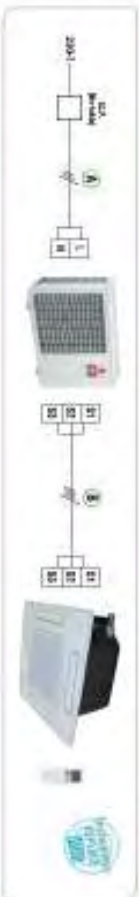

DC INVERTER

DATOS DE INSTALACION

MODELO	dimensiões de instalação		distância de instalação (H)		potência máxima (W)	COP (A/C)	tubo de refrigerante		potência máxima de refrigeração		tubo de drenagem	tubo de gás	tubo de água	tubo de gás	tubo de água
	altura	largura	topo	base			líquido	vácuo	líquido	vácuo					
SL246-070A	2420x17	912x247	517	527	538	18	Ø33-1147	Ø52-047	12	Ø3	Ø3	Ø3	Ø3	Ø3	Ø3
SL46-070A	2425x17	915x247	462	458	810	18	Ø33-1147	Ø52-047	12	Ø3	Ø3	Ø3	Ø3	Ø3	Ø3
SL246-090A	2441x17	918x247	711	627	86	20	Ø33-1147	Ø52-047	20	Ø3	Ø3	Ø3	Ø3	Ø3	Ø3

NOTAS: Para o comprimento superior consulte o manual de instalação página 27.

ERRETTA ANCHESSILI DE BEVERESTABENTE

31,27-02020-001, Para detalhes de instalação consulte o Técnico ERRT + 35974 e endereço de 01-4100-0127-94909-001. Para detalhes de instalação consulte o Técnico ERRT + 35974 e endereço de 01-4100-0127-94909-001.

GAMA POWER INVERTER

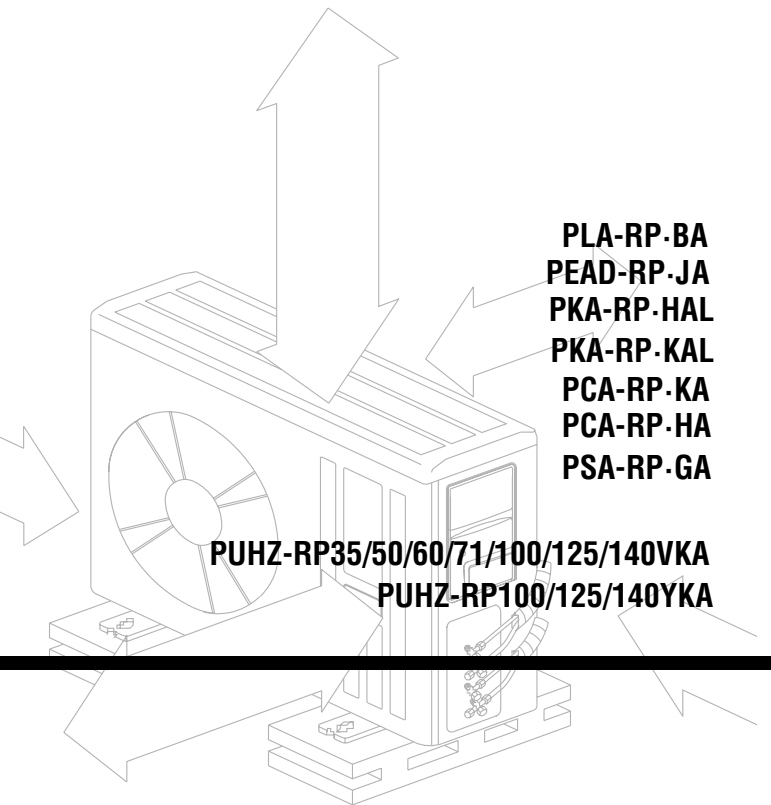

PLA-RP-BA
PEAD-RP-JA
PKA-RP-HAL
PKA-RP-KAL
PCA-RP-KA
PCA-RP-HA
PSA-RP-GA

PUHZ-RP35/50/60/71/100/125/140VKA

PUHZ-RP100/125/140YKA

2-1. CEILING CASSETTE TYPE

Model name	Indoor unit		PLA-RP35BA	PLA-RP50BA	
	Outdoor unit		PUHZ-RP35VHA4	PUHZ-RP50VHA4	
Cooling	Capacity	Btu/h	12,300	17,100	
		kW	3.6(1.6-4.5)	5.0(2.3-6.6)	
	Total input	kW	1.07	1.55	
	EER		3.36	3.23	
	Energy label class		A	A	
Heating	Capacity	Btu/h	14,000	20,500	
		kW	4.1(1.6-5.2)	6.0(2.5-7.3)	
	Total input	kW	1.12	1.66	
	COP		3.66	3.61	
	Energy label class		A	A	
Power supply	Booster heater	kW	-	-	
	Phase	ϕ		1	
	Cycle	Hz		50	
	Voltage	V		230	
	Breaker size	A		16	
Indoor unit	Air flow (Low-Medium2-Medium1-High)	CMM	11-12-13-15	12-14-16-18	
		CFM	390-425-460-530	425-495-565-635	
	External pressure	Pa	0	0	
	Sound level (Low-Medium2-Medium1-High)	dB(A)		27-28-29-31	28-29-31-32
	External finish (Panel)			White Munsell 6.4Y 8.9/0.4	
	Dimension	W : mm		840 (950)	
			D : mm	840 (950)	
	Unit (Panel)	H : mm	258 (35)		
		W : inch	33-1/16 (37-3/8)		
		D : inch	33-1/16 (37-3/8)		
		H : inch	10-3/16 (1-3/8)		
	Weight	kg	22(6)		
	Unit (Panel)	lbs	49(13)		
		Field drain pipe O.D.	mm	32	
	inch	1-1/4			
Outdoor unit	Air flow	CMM	35		
		CFM	1,240		
	Sound level at cooling	dB(A)		44	
				46	
	Sound level at heating	dB(A)		44	
				46	
	External finish			Ivory Munsell 3Y 7.8/1.1	
Dimension	W : mm		800		
		D : mm	300+23		
		H : mm	600		
		W : inch	31-1/2		
		D : inch	11-13/16 + 7/8		
		H : inch	23-5/8		
Weight	kg	42			
	lbs	93			
Refrigerant pipe size	Gas side O.D.	mm	12.7		
		inch	1/2		
	Liquid side O.D.	mm	6.35		
		inch	1/4		
		Height difference	m	Max. 30	
Length	m	Max. 50			

NOTE: 1. Rating conditions (Standard)
 Cooling Indoor D.B. 27°C (80°F) W.B. 19°C (66°F) Outdoor D.B. 35°C (95°F) W.B. 24°C (75°F)
 Heating Indoor D.B. 20°C (68°F) Outdoor D.B. 7°C (45°F) W.B. 6°C (43°F)
 Refrigerant piping length: standard 100-200 m.

2. Overhead operating range

		Indoor	Outdoor
Cooling	Upper limit	D.B. 35°C (95°F) W.B. 24°C (75°F)	D.B. 46°C
	Lower limit	D.B. 18°C (64°F) W.B. 13°C (55°F)	D.B. 23°C
Heating	Upper limit	D.B. 26°C	D.B. 19°C (66°F)
	Lower limit	D.B. 17°C	D.B. 7°C (45°F)

3. Inverter unit rating

1. Inverter unit rating
 2. Inverter unit rating
 3. Inverter unit rating

4. Inverter unit rating
 5. Inverter unit rating
 6. Inverter unit rating

7. Inverter unit rating
 8. Inverter unit rating

Model name	Indoor unit		PLA-RP60BA	PLA-RP71BA	
	Outdoor unit		PUHZ-RP60VHA4	PUHZ-RP71VHA4	
Cooling	Capacity	Btu/h	20,500	24,200	
		kW	6.0(2.7-6.7)	7.1(3.3-8.1)	
	Total input	kW	1.60	2.09	
	EER		3.75	3.40	
	Energy label class		A	-	
	SHF		0.76	0.73	
Heating	Capacity	Btu/h	23,900	27,300	
		kW	7.0(2.8-8.2)	8.0(3.5-10.2)	
	Total input	kW	1.82	2.15	
	COP		3.85	3.72	
	Energy label class		A	-	
	Booster heater	kW	-	-	
Power supply	Phase	ϕ	1		
	Cycle	Hz	50		
	Voltage	V	230		
	Breaker size	A	25		
	Air flow (Low-Medium2-Medium1-High)	CMM	12-14-16-18	14-16-18-21	
External pressure	Pa	0	0		
Sound level (Low-Medium2-Medium1-High)	dB(A)	28-29-31-32	28-30-32-34		
External finish (Panel)	White Munsell 6.4Y 8.9/0.4				
Dimension	Unit (Panel)	W : mm	840 (950)		
		D : mm	840 (950)		
		H : mm	258 (35)		
		W : inch	33-1/16 (37-3/8)		
		D : inch	33-1/16 (37-3/8)		
		H : inch	10-3/16 (1-3/8)		
Weight	kg	23(6)			
	lbs	51(13)			
Field drain pipe O.D.	mm	32			
	inch	1-1/4			
Outdoor unit	Air flow	CMM	60		
		CFM	2,120		
	Sound level at cooling	dB(A)	47		
	Sound level at heating	dB(A)	48		
	External finish	Ivory Munsell 3Y 7.8/1.1			
	Dimension	Unit (Panel)	W : mm	950	
D : mm			330+30		
H : mm			943		
W : inch			37-3/8		
D : inch			13 + 1-3/16		
H : inch			37-1/8		
Weight	kg	67			
	lbs	148			
Refrigerant pipe size	Gas side O.D.	mm	15.88		
		inch	5/8		
	Liquid side O.D.	mm	9.52		
		inch	3/8		
Refrigerant pipe length	Height difference	m	Max. 30		
	Length	m	Max. 50		

NOTE: 1. Rating conditions (ISO T1)

Cooling Indoor : D.B. 27°C (80°F) W.B. 19°C (66°F)

Heating Indoor : D.B. 20°C (68°F)

Refrigerant piping length (one way) : 5m (16ft.)

2. Guaranteed operating range

	Indoor		Outdoor
Cooling	Upper limit	D.B. 35°C, W.B. 22.5°C	D.B. 46°C
	Lower limit	D.B. 19°C, W.B. 15°C	D.B. -5°C
Heating	Upper limit	D.B. 28°C	D.B. 21°C, W.B. 15°C
	Lower limit	D.B. 17°C	D.B. -20°C, W.B. -20°C

3. Guaranteed voltage

198-264V, 50Hz

4. Above data are based on the indicated voltage.

Indoor unit Single phase 230V 50Hz

Outdoor unit Single phase 230V 50Hz

* If optional air protect guide installed, D.B. -15°C

Model name	Indoor unit		PLA-RP71BA2	PLA-RP100BA	PLA-RP100BA3	
Cooling	Outdoor unit		PUHZ-RP71VHA4	PUHZ-RP100VKA	PUHZ-RP100VKA	
	Capacity	Btu/h	24,200	34,100	34,100	
		kW	7.1(3.3-8.1)	10.0(4.9-11.4)	10.0(4.9-11.4)	
	Total input		kW	1.90	2.65	2.39
	EER			3.74	3.77	4.18
	Energy label class			A	-	A
	SHF			0.73	0.74	0.74
Heating	Capacity	Btu/h	27,300	38,200	38,200	
		kW	8.0(3.5-10.2)	11.2(4.5-14.0)	11.2(4.5-14.0)	
	Total input		kW	1.90	2.79	2.43
	COP			4.21	4.01	4.61
	Energy label class			A	-	A
	Booster heater		kW	-	-	-
Power supply	Phase		ϕ			
	Cycle		Hz			
	Voltage		V			
	Breaker size		A	25	32	
	External pressure		Pa	0	0	
Indoor unit	Air flow (Low-Medium2-Medium1-High)		CMM	14-16-18-21	20-23-26-30	
	CFM		495-565-635-740	710-810-920-1060		
	External pressure		Pa	0	0	
	Sound level (Low-Medium2-Medium1-High)		dB(A)	28-30-32-34	32-34-37-40	
	External finish (Panel)		White Munsell 6.4Y 8.9/0.4			
	Dimension Unit (Panel)	W : mm		840 (950)		
		D : mm		840 (950)		
		H : mm		258 (35)	298 (35)	
		W : inch		33-1/16 (37-3/8)		
		D : inch		33-1/16 (37-3/8)		
		H : inch		10-3/16 (1-3/8)	11-3/4 (1-3/8)	
	Weight Unit (Panel)	kg		23(6)	25(6)	26(6)
		lbs		51(13)	55(13)	57(13)
	Field drain pipe O.D.		mm	32		
		inch	1-1/4			
Outdoor unit	Air flow		CMM	60	110	
	CFM		2,120	3,880		
	Sound level at cooling		dB(A)	47	49	
	Sound level at heating		dB(A)	48	51	
	External finish		Ivory Munsell 3Y 7.8/1.1			
	Dimension	W : mm		950	1,050	
		D : mm		330+30		
		H : mm		943	1,338	
		W : inch		37-3/8	41-5/16	
		D : inch		13 + 1-3/16		
		H : inch		37-1/8	52-11/16	
	Weight	kg		67	116	
		lbs		148	256	
	Refrigerant pipe size	Gas side O.D.		mm	15.88	
		inch	5/8			
Liquid side O.D.		mm	9.52			
		inch	3/8			
Refrigerant pipe length	Height difference		m	Max. 30		
	Length		m	Max. 50	Max. 75	

NOTE: 1. Rating conditions (ISO T1)

Cooling Indoor : D.B. 27°C (80°F) W.B. 19°C (66°F) Outdoor : D.B. 35°C (95°F) W.B. 24°C (75°F)
 Heating Indoor : D.B. 20°C (68°F) Outdoor : D.B. 7°C (45°F) W.B. 6°C (43°F)
 Refrigerant piping length (one way) : 5m (16ft.)

2. Guaranteed operating range

		Indoor		Outdoor	
		Upper limit	D.B. 35°C, W.B. 22.5°C	D.B. 46°C	Upper limit
Cooling	Lower limit	D.B. 19°C, W.B. 15°C	D.B. -5°C	∞	
	Upper limit	D.B. 28°C	D.B. 21°C, W.B. 15°C		
Heating	Upper limit	D.B. 17°C	D.B. -20°C, W.B. -20°C		
	Lower limit	D.B. 17°C	D.B. -20°C, W.B. -20°C		

3. Guaranteed voltage

198-264V, 50Hz
 4. Above data are based on the indicated voltage.
 Indoor unit Single phase 230V 50Hz
 Outdoor unit Single phase 230V 50Hz
 ∞ If optional air protect guide installed. D.B.-15°C

Model name	Indoor unit	PLA-RP125BA	PLA-RP125BA2	PLA-RP140BA2
Cooling	Outdoor unit	PUHZ-RP125VKA	PUHZ-RP125VKA	PUHZ-RP140VKA
	Capacity	Btu/h 42,700	42,700	47,800
		kW 12.5(5.5-14.0)	12.5(5.5-14.0)	14.0(6.2-15.3)
	Total input	kW 3.83	3.67	4.36
	EER	3.26	3.41	3.21
	Energy label class	-	A	A
	SHF	0.71	0.71	0.71
Heating	Capacity	Btu/h 47,800	47,800	54,600
		kW 14.0(5.0-16.0)	14.0(5.0-16.0)	16.0(5.7-18.0)
	Total input	kW 3.86	3.50	4.32
	COP	3.63	4.00	3.70
	Energy label class	-	A	A
	Booster heater	kW -	-	-
	Phase	ϕ	1	
Power supply	Cycle	Hz	50	
	Voltage	V	230	
	Breaker size	A	32	40
	Air flow (Low-Medium2-Medium1-High)	CMM	22-25-28-31	22-25-28-31
External pressure	Pa	0	0	0
Sound level (Low-Medium2-Medium1-High)	dB(A)	34-36-39-41	34-36-39-41	36-39-42-44
External finish (Panel)		White Munsell 6.4Y 8.9/0.4		
Dimension	W : mm	840 (950)		
	D : mm	840 (950)		
	H : mm	298 (35)		
	W : inch	33-1/16 (37-3/8)		
	D : inch	33-1/16 (37-3/8)		
	H : inch	11-3/4 (1-3/8)		
Weight	kg	25(6)	27(6)	27(6)
	lbs	55(13)	60(13)	60(13)
Field drain pipe O.D.	mm	32		
	inch	1-1/4		
Outdoor unit	Air flow	CMM	120	
		CFM	4,230	
	Sound level at cooling	dB(A)	50	
	Sound level at heating	dB(A)	52	
	External finish		Ivory Munsell 3Y 7.8/1.1	
	Dimension	W : mm	1,050	
		D : mm	330+30	
		H : mm	1,338	
		W : inch	41-5/16	
		D : inch	13 + 1-3/16	
H : inch		52-11/16		
Weight	kg	116	119	
	lbs	256	262	
Refrigerant pipe size	Gas side O.D.	mm	15.88	
		inch	5/8	
	Liquid side O.D.	mm	9.52	
		inch	3/8	
Refrigerant pipe length	Height difference	m	Max. 30	
	Length	m	Max. 75	

NOTE: 1. Rating conditions (ISO T1)

Cooling Indoor : D.B. 27°C (80°F) W.B. 19°C (66°F)

Outdoor : D.B. 35°C (95°F) W.B. 24°C (75°F)

Heating Indoor : D.B. 20°C (68°F)

Outdoor : D.B. 7°C (45°F) W.B. 6°C (43°F)

Refrigerant piping length (one way) : 5m (16ft.)

2. Guaranteed operating range

	Indoor		Outdoor	
Cooling	Upper limit	D.B. 35°C W.B. 22.5°C	D.B. 46°C	
	Lower limit	D.B. 19°C W.B. 15°C	D.B. -6°C	※
Heating	Upper limit	D.B. 28°C	D.B. 21°C W.B. 15°C	
	Lower limit	D.B. 17°C	D.B. -20°C W.B. -20°C	

3. Guaranteed voltage

198-264V, 50Hz

4. Above data are based on the indicated voltage.

Indoor unit Single phase 230V 50Hz

Outdoor unit Single phase 230V 50Hz

※ If optional air protect guide installed. D.B. -15°C

Model name	Indoor unit	PLA-RP100BA		PLA-RP100BA3		
	Outdoor unit	PUHZ-RP100YKA		PUHZ-RP100YKA		
Cooling	Capacity	Btu/h	34,100	34,100		
		kW	10.0(4.9-11.4)	10.0(4.9-11.4)		
	Total input	kW	2.65	2.39		
	EER		3.77	4.18		
	Energy label class		-	A		
Heating	SHF		0.74	0.74		
	Capacity	Btu/h	38,200	38,200		
		kW	11.2(4.5-14.0)	11.2(4.5-14.0)		
	Total input	kW	2.79	2.43		
COP		4.01	4.61			
Energy label class		-	A			
Power supply	Booster heater	kW	-	-		
	Phase	φ	3			
	Cycle	Hz	50			
	Voltage	V	400			
Indoor unit	Breaker size	A	16			
	Air flow	CMM	20-23-26-30	20-23-26-30		
		CFM	710-810-920-1,060	710-810-920-1,060		
	External pressure	Pa	0			
	Sound level	dB(A)	32-34-37-40	32-34-37-40		
	External finish (Panel)		White Munsell 6.4Y 8.9/0.4			
	Dimension	Unit (Panel)	W : mm	840 (950)		
			D : mm	840 (950)		
			H : mm	298 (35)		
			W : inch	33-1/16 (37-3/8)		
			D : inch	33-1/16 (37-3/8)		
H : inch			11-3/4 (1-3/8)			
Weight	kg	25 (6)	26 (6)			
	Unit (Panel)	lbs	55 (13)	57 (13)		
Field drain pipe O.D.	mm	32				
	inch	1-1/4				
Outdoor unit	Air flow	CMM	110			
		CFM	3,880			
	Sound level at cooling	dB(A)	49			
	Sound level at heating	dB(A)	51			
External finish		Ivory Munsell 3Y 7.8/1.1				
Dimension	Weight	W : mm	1,050			
		D : mm	330*30			
		H : mm	1,338			
		W : inch	41-5/16			
		D : inch	13 + 1-3/16			
		H : inch	52-11/16			
Refrigerant pipe size	Gas side O.D.	mm	15.88			
		inch	5/8			
	Liquid side O.D.	mm	9.52			
		inch	3/8			
Refrigerant pipe length	Height difference	m	Max. 30			
	Length	m	Max. 75			

NOTE: 1. Rating conditions (ISO T1)

Cooling Indoor : D.B. 27°C (80°F) W.B. 19°C (66°F)

Outdoor : D.B. 35°C (95°F) W.B. 24°C (75°F)

Heating Indoor : D.B. 20°C (68°F)

Outdoor : D.B. 7°C (45°F) W.B. 6°C (43°F)

Refrigerant piping length (one way) : 5m (16ft.)

2. Guaranteed operating range

		Indoor		Outdoor	
		Upper limit	Lower limit	Upper limit	Lower limit
Cooling	Upper limit	D.B. 35°C	W.B. 22.5°C	D.B. 46°C	
	Lower limit	D.B. 19°C	W.B. 15°C	D.B. -5°C	※
Heating	Upper limit	D.B. 28°C		D.B. 21°C	W.B. 15°C
	Lower limit	D.B. 17°C		D.B. -20°C	W.B. -20°C

3. Guaranteed voltage

Indoor unit 198~264V, 50Hz

Outdoor unit 342~457V, 50Hz

4. Above data are based on the indicated voltage.

Indoor unit Single phase 230V 50Hz

Outdoor unit 3 phase 400V 50Hz

※ If optional air protect guide installed. D.B. -15°C

Model name	Indoor unit	PLA-RP125BA	PLA-RP125BA2	PLA-RP140BA2	
Cooling	Outdoor unit	PUHZ-RP125YKA	PUHZ-RP125YKA	PUHZ-RP140YKA	
	Capacity	Btu/h	42,700	42,700	47,800
		kW	12.5(5.5-14.0)	12.5(5.5-14.0)	14.0(6.2-15.3)
	Total input	kW	3.83	3.67	4.36
	EER		3.26	3.41	3.21
	Energy label class		-	A	A
	SHF		0.71	0.71	0.71
Heating	Capacity	Btu/h	47,800	47,800	54,600
	Total input	kW	14.0(5.0-16.0)	14.0(5.0-16.0)	16.0(5.7-18.0)
		kW	3.86	3.50	4.32
	COP		3.63	4.00	3.70
	Energy label class		-	A	A
	Booster heater	kW	-	-	-
	Power supply	Phase	ϕ	3	
Cycle		Hz	50		
Voltage		V	400		
Breaker size		A	16		
Indoor unit		Air flow	CMM	22-25-28-31	22-25-28-31
		CFM	780-880-990-1090	780-880-990-1090	850-920-1020-1130
	External pressure	Pa	0	0	0
	Sound level	dB(A)	34-36-39-41	34-36-39-41	36-39-42-44
	External finish (Panel)		White Munsell 6.4Y 8.9/0.4		
	Dimension Unit (Panel)	W : mm	840 (950)		
		D : mm	840 (950)		
		H : mm	298 (35)		
		W : inch	33-1/16 (37-3/8)		
		D : inch	33-1/16 (37-3/8)		
		H : inch	11-3/4 (1-3/8)		
	Weight Unit (Panel)	kg	25(6)	27(6)	27(6)
		lbs	55(13)	60(13)	60(13)
Field drain pipe O.D.	mm	32			
	inch	1-1/4			
Outdoor unit	Air flow	CMM	120		
		CFM	4,230		
	Sound level at cooling	dB(A)	50		
	Sound level at heating	dB(A)	52		
	External finish		Ivory Munsell 3Y 7.8/1.1		
	Dimension	W : mm	1,050		
		D : mm	330+30		
		H : mm	1,338		
		W : inch	41-5/16		
		D : inch	13 + 1-3/16		
		H : inch	52-11/16		
	Weight	kg	126	132	
		lbs	278	291	
Refrigerant pipe size	Gas side O.D.	mm	15.88		
		inch	5/8		
	Liquid side O.D.	mm	9.52		
		inch	3/8		
	Refrigerant pipe length	Height difference	m	Max. 30	
Length		m	Max. 75		

NOTE: 1. Rating conditions (ISO T1)

Cooling Indoor: D.B. 27°C (80°F) W.B. 19°C (66°F)

Outdoor: D.B. 35°C (95°F) W.B. 24°C (75°F)

Heating Indoor: D.B. 20°C (68°F)

Outdoor: D.B. 7°C (45°F) W.B. 6°C (43°F)

Refrigerant piping length (one way) : 5m (16ft.)

2. Guaranteed operating range

Cooling	Upper limit	Indoor		Outdoor
		D.B. 35°C, W.B. 22.5°C	D.B. 46°C	D.B. 46°C
Heating	Lower limit	D.B. 19°C, W.B. 15°C	D.B. -5°C	D.B. -5°C
	Upper limit	D.B. 28°C	D.B. 21°C, W.B. 15°C	D.B. 21°C, W.B. 15°C
	Lower limit	D.B. 17°C	D.B. -20°C, W.B. -20°C	D.B. -20°C, W.B. -20°C

3. Guaranteed voltage

Indoor unit 198-264V, 50Hz

Outdoor unit 342-457V, 50Hz

4. Above data are based on the indicated voltage.

Indoor unit Single phase 230V 50Hz

Outdoor unit 3 phase 400V 50Hz

* If optional air protect guide installed. D.B. -15°C

2-2. CEILING-CONCEALED TYPE

Model name	Indoor unit		PEAD-RP35JA(L)	PEAD-RP50JA(L)
	Outdoor unit		PUHZ-RP35VHA4	PUHZ-RP50VHA4
Cooling	Capacity	Btu/h	12,300	17,100
		kW	3.6(1.6-4.5)	5.0(2.3-5.6)
	Total input	kW	1.02(1.00)	1.55(1.53)
	EER		3.53(3.60)	3.23(3.27)
	Energy label class		A	A
Heating	Capacity	Btu/h	14,000	20,500
		kW	4.1(1.6-5.2)	6.0(2.5-7.3)
	Total input	kW	1.10	1.56
	COP		3.73	3.85
	Energy label class		A	A
Power supply	Booster heater	kW	-	-
	Phase	φ		1
	Cycle	Hz		50
	Voltage	V		230
Indoor unit	Air flow (Low-Middle-High)	CMM	10-12-14	12-14.5-17
		CFM	353-424-494	424-512-600
	External pressure	Pa	35/50/70/100/150	
	Sound level (Low-Middle-High/ 50Pa)	dB(A)	23-27-30	26-31-36
	External finish		Galvanized sheets	
	Dimension	W : mm	900	
		D : mm	732	
		H : mm	250	
		W : inch	35-7/16	
		D : inch	28-7/8	
		H : inch	9-7/8	
	Weight	kg	26(25)	28(27)
		lbs	58(56)	62(60)
Field drain pipe O.D.	mm	32		
	inch	1-1/4		
Outdoor unit	Air flow	CMM	35	
		CFM	1,240	
	Sound level at cooling	dB(A)	44	
	Sound level at heating	dB(A)	46	
	External finish		Ivory Munsell 3Y 7.8/1.1	
	Dimension	W : mm	800	
		D : mm	300+23	
H : mm		600		
W : inch		31-1/2		
D : inch		11-13/16 + 7/8		
H : inch		23-5/8		
Weight	kg	42		
	lbs	93		
Refrigerant pipe size	Gas side O.D.	mm	12.7	
		inch	1/2	
	Liquid side O.D.	mm	6.35	
		inch	1/4	
Refrigerant pipe length	Height difference	m	Max. 30	
	Length	m	Max. 50	

NOTE: 1. Rating conditions (ISO T1)

Cooling Indoor : D.B. 27°C (80°F) W.B. 19°C (66°F)

Heating Indoor : D.B. 20°C (68°F)

Refrigerant piping length (one way) : 5m (16ft.)

Outdoor : D.B. 35°C (95°F) W.B. 24°C (75°F)

Outdoor : D.B. 7°C (45°F) W.B. 6°C (43°F)

2. Guaranteed operating range

		Indoor	Outdoor
Cooling	Upper limit	D.B. 35°C, W.B. 22.5°C	D.B. 46°C
	Lower limit	D.B. 19°C, W.B. 15°C	D.B. -5°C
Heating	Upper limit	D.B. 28°C	D.B. 21°C, W.B. 15°C
	Lower limit	D.B. 17°C	D.B. -11°C, W.B. -12°C

3. Guaranteed voltage

198-264V, 50Hz

4. Above data are based on the indicated voltage.

Indoor unit Single phase 230V 50Hz

Outdoor unit Single phase 230V 50Hz

※ If optional air protect guide installed, D.B. -15°C

Model name	Indoor unit		PEAD-RP60JA(L)	PEAD-RP71JA(L)
Cooling	Outdoor unit		PUHZ-RP60VHA4	PUHZ-RP71VHA4
	Capacity	Btu/h	20,500	24,200
		kW	6.0(2.7-6.7)	7.1(3.3-8.1)
	Total input	kW	1.60(1.58)	2.03(2.01)
	EER		3.75(3.80)	3.50(3.53)
	Energy label class		A	A
SHF		0.83	0.83	
Heating	Capacity	Btu/h	23,900	27,300
		kW	7.0(2.8-8.2)	8.0(3.5-10.2)
	Total input	kW	1.75	2.00
	COP		4.00	4.00
	Energy label class		A	A
	Booster heater	kW	-	-
Power supply	Phase	φ	1	
	Cycle	Hz	50	
	Voltage	V	230	
	Breaker size	A	25	
	Indoor unit	Air flow	CMM	14.5-18-21
(Low-Middle-High)		CFM	512-636-742	618-742-883
External pressure		Pa	35/50/70/100/150	
Sound level (Low-Middle-High/ 50Pa)		dB(A)	25-29-33	26-30-34
External finish			Galvanized sheets	
Dimension		W : mm	1,100	
		D : mm	732	
		H : mm	250	
		W : inch	43-5/16	
		D : inch	28-7/8	
		H : inch	9-7/8	
Weight		kg	33(32)	33(32)
		lbs	73(71)	73(71)
Field drain pipe O.D.	mm	32		
	inch	1-1/4		
Outdoor unit	Air flow	CMM	60	60
		CFM	2,120	2,120
	Sound level at cooling	dB(A)	47	47
	Sound level at heating	dB(A)	48	48
	External finish		Ivory Munsell 3Y 7.8/1.1	
	Dimension	W : mm	950	950
		D : mm	330+30	330+30
		H : mm	943	943
		W : inch	37-3/8	37-3/8
		D : inch	13 + 1-3/16	13 + 1-3/16
		H : inch	37-1/8	37-1/8
	Weight	kg	67	
		lbs	148	
Refrigerant pipe size	Gas side O.D.	mm	15.88	15.88
		inch	5/8	5/8
	Liquid side O.D.	mm	9.52	9.52
		inch	3/8	3/8
Refrigerant pipe length	Height difference	m	Max. 30	Max. 30
	Length	m	Max. 50	Max. 50

NOTE: 1. Rating conditions (ISO T1)

Cooling Indoor : D.B. 27°C (80°F) W.B. 19°C (66°F)

Heating Indoor : D.B. 20°C (68°F)

Refrigerant piping length (one way) : 5m (16ft.)

Outdoor : D.B. 35°C (95°F) W.B. 24°C (75°F)

Outdoor : D.B. 7°C (45°F) W.B. 6°C (43°F)

2. Guaranteed operating range

		Indoor		Outdoor	
Cooling	Upper limit	D.B. 35°C, W.B. 22.5°C	D.B. 46°C		
	Lower limit	D.B. 19°C, W.B. 15°C	D.B. -5°C	≅	
Heating	Upper limit	D.B. 28°C	D.B. 21°C, W.B. 15°C		
	Lower limit	D.B. 17°C	D.B. -20°C, W.B. -20°C		

3. Guaranteed voltage

198-264V, 50Hz

4. Above data are based on the indicated voltage.

Indoor unit Single phase 230V 50Hz

Outdoor unit Single phase 230V 50Hz

≅ If optional air protect guide installed. D.B. -15°C

Model name	Indoor unit		PEAD-RP100JA(L)	PEAD-RP125JA(L)	PEAD-RP140JA(L)	
Cooling	Outdoor unit		PUHZ-RP100VKA	PUHZ-RP125VKA	PUHZ-RP140VKA	
	Capacity	Btu/h	34,100	42,700	47,800	
		kW	10.0(4.9-11.4)	12.5(5.5-14.0)	14.0(6.2-15.3)	
	Total input	kW	2.77(2.75)	3.86(3.84)	4.36(4.34)	
	EER		3.61(3.64)	3.24(3.26)	3.21(3.23)	
	Energy label class			A	A	
SHF			0.82	0.84		
Heating	Capacity	Btu/h	38,200	47,800	54,600	
		kW	11.2(4.5-14.0)	14.0(5.0-16.0)	16.0(5.7-18.0)	
	Total input	kW	2.72	3.50	4.04	
	COP		4.12	4.00	3.96	
	Energy label class			A	A	
	Booster heater		kW	-	-	-
Power supply	Phase		ϕ			
	Cycle		Hz			
	Voltage		V			
	Breaker size		A			
	Air flow		CMM	24-29-34	29.5-35.5-42	32-39-46
(Low-Middle-High)		CFM	847-1,024-1,201	1,042-1,253-1,483	1,130-1,377-1,624	
External pressure		Pa	35/50/70/100/150			
Sound level (Low-Middle-High50Pa)		dB(A)	29-34-38	33-36-40	34-38-43	
External finish		Galvanized sheets				
Dimension	W : mm		1,400		1,600	
	D : mm		732			
	H : mm		250			
	W : inch		55-1/8		63	
	D : inch		28-7/8			
	H : inch		9-7/8			
	Weight	kg	41(40)	43(42)	47(46)	
lbs		91(89)	95(93)	104(102)		
Field drain pipe O.D.	mm		32			
	inch		1-1/4			
Outdoor unit	Air flow		CMM	110	120	
			CFM	3,880	4,230	
	Sound level at cooling		dB(A)	49	50	
	Sound level at heating		dB(A)	51	52	
	External finish		Ivory Munsell 3Y 7.8/1.1			
	Dimension	W : mm		1,050		
		D : mm		330+30		
		H : mm		1,338		
		W : inch		41-5/16		
		D : inch		13 + 1-3/16		
	H : inch		52-11/16			
Weight	kg	116	116	119		
	lbs	256	256	262		
Refrigerant pipe size	Gas side O.D.		mm			
			15.88			
			inch			
			5/8			
Liquid side O.D.		mm				
		9.52				
		inch				
		3/8				
Refrigerant pipe length	Height difference		m			
	Length		Max. 30			
		m				
		Max. 75				

NOTE: 1. Rating conditions (ISO T1)

Cooling Indoor : D.B. 27°C (80°F) W.B. 19°C (66°F) Outdoor : D.B. 35°C (95°F) W.B. 24°C (75°F)
 Heating Indoor : D.B. 20°C (68°F) Outdoor : D.B. 7°C (45°F) W.B. 6°C (43°F)

Refrigerant piping length (one way) : 5m (16ft.)

2. Guaranteed operating range

	Indoor		Outdoor	
	Cooling	Upper limit D.B. 35°C, W.B. 22.5°C	D.B. 46°C	Upper limit D.B. 35°C, W.B. 22.5°C
	Lower limit D.B. 19°C, W.B. 15°C	D.B. -5°C	Lower limit D.B. 19°C, W.B. 15°C	D.B. -5°C
Heating	Upper limit D.B. 28°C	D.B. 27°C, W.B. 15°C	Upper limit D.B. 28°C	D.B. 27°C, W.B. 15°C
	Lower limit D.B. 17°C	D.B. -20°C, W.B. -20°C	Lower limit D.B. 17°C	D.B. -20°C, W.B. -20°C

3. Guaranteed voltage

198~264V, 50Hz

4. Above data are based on the indicated voltage.

Indoor unit Single phase 230V 50Hz

Outdoor unit Single phase 230V 50Hz

Ⓐ If optional air protect guide installed. D.B. -15°C

Model name	Indoor unit		PEAD-RP100JA(L)	PEAD-RP125JA(L)	PEAD-RP140JA(L)
	Outdoor unit		PUHZ-RP100YKA	PUHZ-RP125YKA	PUHZ-RP140YKA
Cooling	Capacity	Btu/h	34,100	42,700	47,800
		kW	10.0(4.9-11.4)	12.5(5.5-14.0)	14.0(6.2-15.3)
	Total input	kW	2.77(2.75)	3.86(3.84)	4.36(4.34)
	EER		3.61(3.64)	3.24(3.26)	3.21(3.23)
	Energy label class		A	A	A
	SHF		0.82	0.84	0.83
Heating	Capacity	Btu/h	38,200	47,800	54,600
		kW	11.2(4.5-14.0)	14.0(5.0-16.0)	16.0(5.7-18.0)
	Total input	kW	2.72	3.50	4.04
	COP		4.12	4.00	3.96
	Energy label class		A	A	A
	Booster heater	kW	-	-	-
Power supply	Phase	φ		3	
	Cycle	Hz		50	
	Voltage	V		400	
	Breaker size	A		16	
Indoor unit	Air flow	CMM	24-29-34	29.5-35.5-42	32-39-46
	(Low-Middle-High)	CFM	847-1,024-1,201	1,042-1,253-1,483	1,130-1,377-1,624
	External pressure	Pa	35/50/70/100/150		
	Sound level	dB(A)	29-34-38	33-36-40	34-38-43
	(Low-Middle-High/50Pa)				
	External finish		Galvanized sheets		
	Dimension	W : mm		1,400	1,600
			D : mm	732	
		H : mm		250	
		W : inch		55-1/8	63
			D : inch	28-7/8	
		H : inch		9-7/8	
	Weight	kg	41(40)	43(42)	47(46)
lbs		91(89)	95(93)	104(102)	
Field drain pipe O.D.	mm	32			
	inch	1-1/4			
Outdoor unit	Air flow	CMM	110	120	
		CFM	3,880	4,230	
	Sound level at cooling	dB(A)	49	50	
	Sound level at heating	dB(A)	51	52	
	External finish		Ivory Munsell 3Y 7.8/1.1		
	Dimension	W : mm		1,050	
			D : mm	330+30	
		H : mm		1,338	
		W : inch		41-5/16	
			D : inch		13 + 1-3/16
H : inch			52-11/16		
Weight	kg	124	126	132	
	lbs	273	278	291	
Refrigerant pipe size	Gas side O.D.	mm	15.88		
		inch	5/8		
	Liquid side O.D.	mm	9.52		
		inch	3/8		
Refrigerant pipe length	Height difference	m	Max. 30		
	Length	m	Max. 75		

NOTE: 1. Rating conditions (ISO T1)

Cooling Indoor : D.B. 27°C (80°F) W.B. 19°C (66°F) Outdoor : D.B. 35°C (95°F) W.B. 24°C (75°F)

Heating Indoor : D.B. 20°C (68°F) Outdoor : D.B. 7°C (45°F) W.B. 6°C (43°F)

Refrigerant piping length (one way) : 5m (16ft.)

2. Guaranteed operating range

	Indoor		Outdoor	
Cooling	Upper limit	D.B. 35°C, W.B. 22.5°C	D.B. 46°C	
	Lower limit	D.B. 19°C, W.B. 15°C	D.B. -5°C	※
Heating	Upper limit	D.B. 28°C	D.B. 21°C, W.B. 15°C	
	Lower limit	D.B. 17°C	D.B. -20°C, W.B. -20°C	

3. Guaranteed voltage

Indoor unit 198-264V, 50Hz

Outdoor unit 342-457V, 50Hz

4. Above data are based on the indicated voltage.

Indoor unit Single phase 230V 50Hz

Outdoor unit 3 phase 400V 50Hz

※ If optional air protect guide installed, D.B. -15°C

Model name	Indoor unit		PEA-RP200GA	PEA-RP250GA	
	Outdoor unit		PUHZ-RP200YKA	PUHZ-RP250YKA	
Cooling	Capacity	Btu/h	65,000	75,000	
		kW	19.0(9.0-22.4)	22.0(11.2-28.0)	
	Total input	kW	6.70	8.34	
	EER		2.84	2.64	
	Energy label class		-	-	
Heating	Capacity	Btu/h	0.81	0.86	
		kW	22.4(9.5-25.0)	27.0(12.5-31.5)	
	Total input	kW	6.50	8.20	
	COP		3.45	3.29	
	Energy label class		-	-	
	Booster heater	kW	-	-	
Power supply	Phase	φ	3		
	Cycle	Hz	50		
	Voltage	V	400		
	Breaker size	A	Indoor 15 / Outdoor 32		
Indoor unit	Air flow	CMM	52-65	64-80	
	(Low-High)	CFM	1835-2295	2260-2825	
	External pressure	Pa	150		
	Sound level	dB(A)	48-51		
	(Low-High)		49-52		
	External finish	Galvanized steel			
	Dimension	W : mm	1400	1600	
		D : mm	634		
		H : mm	400		
		W : inch	55-1/8	63	
		D : inch	25		
		H : inch	15-3/4		
	Weight	kg	70	77	
lbs		155	170		
Unit drain pipe	R1				
Outdoor unit	Air flow	CMM	140		
		CFM	4,940		
	Sound level at cooling	dB(A)	58		
	Sound level at heating	dB(A)	59		
	External finish	Ivory Munsell 3Y 7.8/1.1			
	Dimension	W : mm	1,050		
		D : mm	330+30		
		H : mm	1,338		
		W : inch	41-5/16		
		D : inch	13 + 1-3/16		
		H : inch	52-11/16		
Weight	kg	135	141		
	lbs	297	311		
Refrigerant pipe size	Gas side O.D.	mm	25.4		
		inch	1		
	Liquid side O.D.	mm	9.52	12.7	
		inch	3/8	1/2	
Refrigerant pipe length	Height difference	m	Max. 30		
	Length	m	Max. 100		

NOTE: 1. Rating conditions (ISO T1)

Cooling Indoor : D.B. 27°C (80°F) W.B. 19°C (66°F)

Outdoor : D.B. 35°C (95°F) W.B. 24°C (75°F)

Heating Indoor : D.B. 20°C (68°F)

Outdoor : D.B. 7°C (45°F) W.B. 6°C (43°F)

Refrigerant piping length (one way) : 5m (16ft.)

2. Guaranteed operating range

		Indoor		Outdoor	
Cooling	Upper limit	D.B. 35°C	W.B. 22.5°C	D.B. 46°C	
	Lower limit	D.B. 19°C	W.B. 15°C	D.B. -5°C	≧1
Heating	Upper limit	D.B. 28°C		D.B. 21°C	W.B. 15°C
	Lower limit	D.B. 17°C		D.B. -20°C	W.B. -20°C

3. Guaranteed voltage

342-457V, 50Hz

4. Above data are based on the indicated voltage.

Indoor unit 3 phase 400V 50Hz

Outdoor unit 3 phase 400V 50Hz

≧1. If optional air protect guide is installed : D.B. -15°C

Model name	Indoor unit		PEA-RP400GA	PEA-RP500GA
	Outdoor unit		PUHZ-RP200YKA×2	PUHZ-RP250YKA×2
Cooling	Capacity	Btu/h	130,000	150,000
		kW	38.0(18.0-44.8)	44.0(22.4-56.0)
	Total input	kW	12.95	17.16
	EER		2.93	2.56
	Energy label class		-	-
Heating	Capacity	Btu/h	0.75	0.77
		kW	153,000	184,000
	Total input	kW	44.8(18.0-50.0)	54.0(25.0-63.0)
	COP		12.55	16.88
	Energy label class		3.57	3.20
	Booster heater	kW	-	-
Power supply	Phase	φ	3	
	Cycle	Hz	50	
	Voltage	V	400	
	Breaker size	A	Indoor 15 / Outdoor 32 × 2	
Indoor unit	Air flow	CMM	120	160
		(High)	CFM	4240
	External pressure	Pa	150	
	Sound level	dB(A)	52	53
	(High)			
	External finish	Galvanized steel		
	Dimension	W : mm	1,947	
			764	
		H : mm	595	
			79-11/16	
		D : inch	30-1/8	
			23-7/16	
	Weight	kg	130	133
		lbs	286	293
Unit drain pipe	R1			
Outdoor unit (Per 1 outdoor unit)	Air flow	CMM	140	
		CFM	4,940	
	Sound level at cooling	dB(A)	58	
	Sound level at heating	dB(A)	59	
	External finish	Ivory Munsell 3Y 7.8/1.1		
	Dimension	W : mm	1,050	
			330+30	
		H : mm	1,338	
			41-5/16	
		D : inch	13 + 1-3/16	
52-11/16				
Weight	kg	135	141	
	lbs	297	311	
Refrigerant pipe size	Gas side O.D.	mm	25.4 × 2	
		inch	1 × 2	
	Liquid side O.D.	mm	9.52 × 2	
		inch	3/8 × 2	
Refrigerant pipe length	Height difference	m	Max. 30	
	Length	m	Max. 100 (per 1 outdoor unit)	

NOTE: 1. Rating conditions (ISO T1)

Cooling Indoor : D.B. 27°C (80°F) W.B. 19°C (66°F) Outdoor : D.B. 35°C (95°F) W.B. 24°C (75°F)
 Heating Indoor : D.B. 20°C (68°F) Outdoor : D.B. 7°C (45°F) W.B. 6°C (43°F)

Refrigerant piping length (one way) : 5m (16ft.)

2. Guaranteed operating range

	Indoor		Outdoor
Cooling	Upper limit	D.B. 35°C, W.B. 22.5°C	D.B. 46°C
	Lower limit	D.B. 19°C, W.B. 15°C	D.B. -5°C
Heating	Upper limit	D.B. 28°C	D.B. 21°C, W.B. 15°C
	Lower limit	D.B. 17°C	D.B. -20°C, W.B. -20°C

3. Guaranteed voltage

342-457V, 50Hz

4. Above data are based on the indicated voltage.

Indoor unit 3 phase 400V 50Hz

Outdoor unit 3 phase 400V 50Hz

※1. If optional air protect guide is installed : D.B. -15°C

2-3. WALL MOUNTED TYPE

Model name	Indoor unit		PKA-RP35HAL	PKA-RP50HAL	
	Outdoor unit		PUHZ-RP35VHA4	PUHZ-RP50VHA4	
Cooling	Capacity	Btu/h	12,300	15,700	
		kW	3.6(1.6-4.5)	4.6(2.3-5.6)	
	Total input	kW	0.98	1.43	
	EER		3.67	3.22	
	Energy label class		A	A	
Heating	Capacity	Btu/h	14,000	17,100	
		kW	4.1(1.6-5.2)	5.0(2.5-7.3)	
	Total input	kW	1.13	1.38	
	COP		3.63	3.62	
	Energy label class		A	A	
Power supply	Booster heater	kW	-	-	
	Phase	φ	1		
	Cycle	Hz	50		
	Voltage	V	230		
	Breaker size	A	16		
Indoor unit	Air flow	CMM	9-10.5-12		
	(Low-Middle-High)	CFM	320-370-425		
	External pressure	Pa	0		
	Sound level				
	(Low-Middle-High)	dB(A)	36-40-43		
	External finish		White Munsell 1.0Y 9.2/0.2		
	Dimension	W : mm	898		
		D : mm	249		
		H : mm	295		
		W : inch	35-3/8		
		D : inch	9-13/16		
		H : inch	11-5/8		
	Weight	kg	13		
		lbs	29		
	Field drain pipe I.D.	mm	16		
inch		5/8			
Outdoor unit	Air flow	CMM	35		
		CFM	1,240		
	Sound level at cooling	dB(A)	44		
	Sound level at heating	dB(A)	46		
	External finish		Ivory Munsell 3Y 7.8/1.1		
	Dimension	W : mm	800		
		D : mm	300+23		
		H : mm	600		
		W : inch	31-1/2		
		D : inch	11-13/16 + 7/8		
H : inch		23-5/8			
Weight	kg	42			
	lbs	93			
Refrigerant pipe size	Gas side O.D.	mm	12.7		
		inch	1/2		
	Liquid side O.D.	mm	6.35		
		inch	1/4		
Refrigerant pipe length	Height difference	m	Max. 30		
	Length	m	Max. 50		

NOTE: 1. Rating conditions (ISO T1)

Cooling Indoor : D.B. 27°C (80°F) W.B. 19°C (66°F)

Heating Indoor : D.B. 20°C (68°F)

Refrigerant piping length (one way) : 5m (16ft.)

Outdoor : D.B. 35°C (95°F) W.B. 24°C (75°F)

Outdoor : D.B. 7°C (45°F) W.B. 6°C (43°F)

2. Guaranteed operating range

	Indoor		Outdoor
Cooling	Upper limit	D.B. 35°C, W.B. 22.5°C	D.B. 46°C
	Lower limit	D.B. 19°C, W.B. 15°C	D.B. -5°C
Heating	Upper limit	D.B. 28°C	D.B. 21°C, W.B. 15°C
	Lower limit	D.B. 17°C	D.B. -11°C, W.B. -12°C

3. Guaranteed voltage

198-264V, 50Hz

4. Above data are based on the indicated voltage.

Indoor unit Single phase 230V 50Hz

Outdoor unit Single phase 230V 50Hz

※ If optional air protect guide installed. D.B. -15°C

Model name	Indoor unit	PKA-RP60KAL	PKA-RP71KAL	PKA-RP100KAL	PKA-RP100KAL	
Cooling	Outdoor unit	PUHZ-RP60VHA4	PUHZ-RP71VHA4	PUHZ-RP100VKA	PUHZ-RP100YKA	
	Capacity	Btu/h	20,500	24,200	34,100	34,100
		kW	6.0(2.7-6.7)	7.1(3.3-8.1)	10.0(4.9-11.4)	10.0(4.9-11.4)
	Total input	kW	1.54	1.96	2.90	2.90
	EER		3.90	3.62	3.45	3.45
	Energy label class		A	A	A	A
	SHF		0.86	0.78	0.73	0.73
Heating	Capacity	Btu/h	23,900	27,300	38,200	38,200
		kW	7.0(2.8-8.2)	8.0(3.5-10.2)	11.2(4.5-14.0)	11.2(4.5-14.0)
	Total input	kW	1.76	2.13	3.10	3.10
	COP		3.98	3.76	3.61	3.61
	Energy label class		A	A	A	A
	Booster heater	kW	-	-	-	-
	Power supply	Phase	φ	1		3
Cycle		Hz		50	50	
Voltage		V		230	400	
Breaker size		A	25	25	32	16
Indoor unit		Air flow (Low-Middle-High)	CMM	18-20-22		20-23-26
		CFM	635-705-780		705-810-920	
	External pressure	Pa	0			
	Sound level (Low-Middle-High)	dB(A)	39-42-45		41-45-49	
	External finish		Munsell 1.0Y 9.2/0.2			
	Dimension	W : mm	1,170			
		D : mm	295			
		H : mm	365			
		W : inch	46-1/16			
		D : inch	11-5/8			
		H : inch	14-3/8			
	Weight	kg	21			
		lbs	46			
	Field drain pipe I.D.	mm	16			
		inch	5/8			
Outdoor unit	Air flow	CMM	60		110	
		CFM	2,120		3,880	
	Sound level at cooling	dB(A)	47		49	
	Sound level at heating	dB(A)	48		51	
	External finish		Ivory Munsell 3Y 7.8/1.1			
	Dimension	W : mm	950		1,050	
		D : mm		330+30		
		H : mm	943		1,338	
		W : inch	37-3/8		41-5/16	
		D : inch		13 + 1-3/16		
H : inch		37-1/8		52-11/16		
Weight	kg	67		116		
	lbs	148		256		
Refrigerant pipe size	Gas side O.D.	mm	15.88			
		inch	5/8			
	Liquid side O.D.	mm	9.52			
		inch	3/8			
Refrigerant pipe length	Height difference	m	Max. 30		Max. 30	
	Length	m	Max. 50		Max. 75	

NOTE: 1. Rating conditions (ISO T1)

- Cooling Indoor : D.B. 27°C (80°F) W.B. 19°C (66°F) Outdoor : D.B. 35°C (95°F) W.B. 24°C (75°F)
 Heating Indoor : D.B. 20°C (68°F) Outdoor : D.B. 7°C (45°F) W.B. 6°C (43°F)
 Refrigerant piping length (one way) : 5m (16ft.)

2. Guaranteed operating range

	Indoor	Outdoor
Cooling	Upper limit D.B. 35°C, W.B. 22.5°C	D.B. 46°C
	Lower limit D.B. 19°C, W.B. 15°C	D.B. -5°C ※
Heating	Upper limit D.B. 28°C	D.B. 21°C, W.B. 15°C
	Lower limit D.B. 17°C	D.B. -20°C, W.B. -20°C

3. Guaranteed voltage

- 198-264V, 50Hz (RP100Y: 342-457V, 50Hz)
 4. Above data are based on the indicated voltage.
 Indoor unit Single phase 230V 50Hz
 Outdoor unit V: Single phase 230V 50Hz
 Y: 3phase 400V 50Hz
 ※ If optional air protect guide installed. D.B. -15°C

2-4. CEILING SUSPENDED TYPE

Model name	Indoor unit	PCA-RP50KA	PCA-RP60KA	PCA-RP71KA	
	Outdoor unit	PUHZ-RP50VHA4	PUHZ-RP60VHA4	PUHZ-RP71VHA4	
Cooling	Capacity	Btu/h	17,100	20,500	
		kW	5.0(2.3-5.6)	6.0(2.7-6.7)	7.1(3.3-8.1)
	Total input	kW	1.56	1.50	1.96
	EER		3.21	4.00	3.62
	Energy label class		A	A	A
	SHF		0.79	0.81	0.76
Heating	Capacity	Btu/h	18,800	23,900	27,300
		kW	5.5(2.5-6.6)	7.0(2.8-8.2)	8.0(3.5-10.2)
	Total input	kW	1.52	1.94	2.21
	COP		3.62	3.61	3.62
	Energy label class		A	A	A
	Booster heater		kW	-	-
Power supply	Phase	ϕ	1		
	Cycle	Hz	50		
	Voltage	V	230		
	Breaker size	A	16	25	
	Indoor unit	Air flow (Low-Medium2-Medium1-High)	CMM	10-11-13-15	15-16-17-19
External pressure	CFM	355-390-460-530	530-565-600-670	565-600-635-705	
External pressure	Pa	0			
Sound level (Low-Medium2-Medium1-High)	dB(A)	32-34-37-40	33-35-37-40	35-37-39-41	
External finish		White Munsell 6.4Y 8.9/0.4			
Dimension	W : mm	960	1,280		
		D : mm	680		
		H : mm	230		
	W : inch	37-13/16	50-3/8		
		D : inch	26-3/4		
		H : inch	9-1/16		
Weight	kg	25	32		
	lbs	55	71		
Field drain pipe O.D.	mm	26			
	inch	1			
Outdoor unit	Air flow	CMM	35	60	
		CFM	1,240	2,120	
	Sound level at cooling	dB(A)	44	47	
	Sound level at heating	dB(A)	46	48	
	External finish		Ivory Munsell 3Y 7.8/1.1		
	Dimension	W : mm	800	950	
		D : mm	330+23	330+30	
		H : mm	600	943	
		W : inch	31-1/2	37-3/8	
		D : inch	13 + 7/8	13 + 1-3/16	
Weight	H : inch	23-5/8	37-1/8		
	kg	42	67		
Refrigerant pipe size	Gas side O.D.	mm	12.7	15.88	
		inch	1/2	5/8	
	Liquid side O.D.	mm	6.35	9.52	
		inch	1/4	3/8	
Refrigerant pipe length	Height difference	m	Max. 30	Max. 30	
	Length	m	Max. 50	Max. 50	

NOTE: 1. Rating conditions (ISO T1)

Cooling Indoor : D.B. 27°C (80°F) W.B. 19°C (66°F)

Heating Indoor : D.B. 20°C (68°F)

Refrigerant piping length (one way) : 5m (16ft.)

2. Guaranteed operating range

	Indoor		Outdoor	
Cooling	Upper limit	D.B. 35°C, W.B. 22.5°C	D.B. 46°C	
	Lower limit	D.B. 19°C, W.B. 15°C	D.B. -5°C	±1
Heating	Upper limit	D.B. 28°C	D.B. 21°C, W.B. 15°C	
	Lower limit	D.B. 17°C	D.B. -11°C, W.B. -12°C	±2

3. Guaranteed voltage

198~264V, 50Hz

4. Above data are based on the indicated voltage.

Indoor unit Single phase 230V 50Hz

Outdoor unit Single phase 230V 50Hz

※1. If optional air protect guide installed. D.B. -15°C

※2. For RP60/71 D.B. -20°C, W.B. -20°C

Model name	Indoor unit	PCA-RP100KA	PCA-RP125KA	PCA-RP140KA	
	Outdoor unit	PUHZ-RP100VKA	PUHZ-RP125VKA	PUHZ-RP140VKA	
Cooling	Capacity	Btu/h	34,100	42,700	47,800
		kW	10.0(4.9-11.4)	12.5(5.5-14.0)	14.0(6.2-15.3)
	Total input	kW	2.63	3.88	4.36
	EER		3.80	3.22	3.21
	Energy label class		A	A	A
	SHF		0.77	0.72	0.71
Heating	Capacity	Btu/h	38,200	47,800	54,600
		kW	11.2(4.5-14.0)	14.0(5.0-16.0)	16.0(5.7-18.0)
	Total input	kW	3.02	3.88	4.43
	COP		3.71	3.61	3.61
	Energy label class		A	A	A
	Booster heater	kW	-	-	-
Power supply	Phase	ϕ	1		
	Cycle	Hz	50		
	Voltage	V	230		
	Breaker size	A	32	40	
Indoor unit	Air flow	CMM	22-24-26-28	23-25-27-29	24-26-29-32
	(Low-Medium2-Medium1-High)	CFM	775-850-920-990	810-885-955-1,025	850-920-1,025-1,130
	External pressure	Pa	0		
	Sound level (Low-Medium2-Medium1-High)	dB(A)	37-39-41-43	39-41-43-45	41-43-45-48
	External finish		White Munsell 6.4Y 8.9/0.4		
	Dimension	W : mm		1,600	
D : mm			680		
H : mm			230		
W : inch			63		
D : inch			26-3/4		
H : inch			9-1/16		
Weight	kg	36	38	39	
	lbs	79	84	86	
Field drain pipe O.D.	mm	26			
	inch	1			
Outdoor unit	Air flow	CMM	110	120	
		CFM	3,880	4,230	
	Sound level at cooling	dB(A)	49	50	
	Sound level at heating	dB(A)	51	52	
	External finish		Ivory Munsell 3Y 7.8/1.1		
	Dimension	W : mm		1,050	
D : mm			330+30		
H : mm			1,338		
W : inch			41-5/16		
D : inch			13 + 1-3/16		
H : inch			52-11/16		
Weight	kg	116	119		
	lbs	256	262		
Refrigerant pipe size	Gas side O.D.	mm	15.88		
		inch	5/8		
	Liquid side O.D.	mm	9.52		
		inch	3/8		
Refrigerant pipe length	Height difference	m	Max. 30		
	Length	m	Max. 75		

NOTE: 1. Rating conditions (ISO T1)

Cooling Indoor: D.B. 27°C (80°F) W.B. 19°C (66°F)

Outdoor: D.B. 35°C (95°F) W.B. 24°C (75°F)

Heating Indoor: D.B. 20°C (68°F)

Outdoor: D.B. 7°C (45°F) W.B. 6°C (43°F)

Refrigerant piping length (one way): 5m (16ft.)

2. Guaranteed operating range

		Indoor	Outdoor
Cooling	Upper limit	D.B. 35°C, W.B. 22.5°C	D.B. 46°C
	Lower limit	D.B. 19°C, W.B. 15°C	D.B. -5°C
Heating	Upper limit	D.B. 28°C	D.B. 21°C, W.B. 15°C
	Lower limit	D.B. 17°C	D.B. -20°C, W.B. -20°C

3. Guaranteed voltage

198-264V, 50Hz

4. Above data are based on the indicated voltage.

Indoor unit Single phase 230V 50Hz

Outdoor unit Single phase 230V 50Hz

※ If optional air protect guide installed, D.B. -15°C

Model name	Indoor unit	PCA-RP100KA	PCA-RP125KA	PCA-RP140KA	
	Outdoor unit	PUHZ-RP100YKA	PUHZ-RP125YKA	PUHZ-RP140YKA	
Cooling	Capacity	Btu/h	34,100	42,700	47,800
		kW	10.0(4.9-11.4)	12.5(5.5-14.0)	14.0(6.2-15.3)
	Total input	kW	2.63	3.88	4.36
	EER		3.80	3.22	3.21
	Energy label class		A	A	A
	SHF		0.77	0.72	0.71
Heating	Capacity	Btu/h	38,200	47,800	54,600
		kW	11.2(4.5-14.0)	14.0(5.0-16.0)	16.0(5.7-18.0)
	Total input	kW	3.02	3.88	4.43
	COP		3.71	3.61	3.61
	Energy label class		A	A	A
	Booster heater	kW	-	-	-
Power supply	Phase	φ	3		
	Cycle	Hz	50		
	Voltage	V	400		
	Breaker size	A	16		
Indoor unit	Air flow	CMM	22-24-26-28	23-25-27-29	24-26-29-32
	(Low-Medium2-Medium1-High)	CFM	775-850-920-990	810-885-955-1,025	850-920-1,025-1,130
	External pressure	Pa	0		
	Sound level (Low-Medium2-Medium1-High)	dB(A)	37-39-41-43	39-41-43-45	41-43-45-48
	External finish		White Munsell 6.4Y 8.9/0.4		
	Dimension	W : mm	1,600		
		D : mm	680		
		H : mm	230		
		W : inch	63		
		D : inch	26-3/4		
		H : inch	9-1/16		
	Weight	kg	36	38	39
		lbs	79	84	86
	Field drain pipe O.D.	mm	26		
inch		1			
Outdoor unit	Air flow	CMM	110	120	
		CFM	3,880	4,230	
	Sound level at cooling	dB(A)	49	50	
	Sound level at heating	dB(A)	51	52	
	External finish		Ivory Munsell 3Y 7.8/1.1		
	Dimension	W : mm	1,050		
D : mm		330*30			
H : mm		1,338			
W : inch		41-5/16			
D : inch		13 + 1-3/16			
H : inch		52-11/16			
Weight	kg	124	126	132	
	lbs	273	278	291	
Refrigerant pipe size	Gas side O.D.	mm	15.88		
		inch	5/8		
	Liquid side O.D.	mm	9.52		
		inch	3/8		
Refrigerant pipe length	Height difference	m	Max. 30		
	Length	m	Max. 75		

NOTE: 1. Rating conditions (ISO T1)

Cooling Indoor : D.B. 27°C (80°F) W.B. 19°C (66°F) Outdoor : D.B. 35°C (95°F) W.B. 24°C (75°F)
 Heating Indoor : D.B. 20°C (68°F) Outdoor : D.B. 7°C (45°F) W.B. 6°C (43°F)

Refrigerant piping length (one way) : 5m (16ft.)

2. Guaranteed operating range

		Indoor	Outdoor
Cooling	Upper limit	D.B. 35°C, W.B. 22.5°C	D.B. 46°C
	Lower limit	D.B. 19°C, W.B. 15°C	D.B. -5°C ※
Heating	Upper limit	D.B. 28°C	D.B. 21°C, W.B. 15°C
	Lower limit	D.B. 17°C	D.B. -20°C, W.B. -20°C

3. Guaranteed voltage

Indoor unit 198-264V, 50Hz

Outdoor unit 342-457V, 50Hz

4. Above data are based on the indicated voltage.

Indoor unit Single phase 230V 50Hz

Outdoor unit 3 phase 400V 50Hz

※ If optional air protect guide installed. D.B. -15°C

Model name	Indoor unit		PCA-RP71HA	PCA-RP125HA	PCA-RP125HA	
	Outdoor unit		PUHZ-RP71VHA4	PUHZ-RP125VKA	PUHZ-RP125YKA	
Cooling	Capacity	Btu/h	24,200	42,700	42,700	
		kW	7.1(3.3-8.1)	12.5(5.5-14.0)	12.5(5.5-14.0)	
	Total input	kW	2.21	3.88	3.88	
	EER		3.21	3.22	3.22	
	Energy label class			A	A	
	SHF			0.74	0.77	
Heating	Capacity	Btu/h	25,900	47,100	47,100	
		kW	7.6(3.5-10.2)	13.8(5.0-16.0)	13.8(5.0-16.0)	
	Total input	kW	2.23	4.05	4.05	
	COP		3.41	3.41	3.41	
	Energy label class			B	B	
	Booster heater		kW	-	-	-
Power supply	Phase	φ	1	3	3	
	Cycle	Hz	50	50	50	
	Voltage	V	230	400	400	
	Breaker size	A	25	16	16	
	Indoor unit					
Air flow	CMM	17-19	30-38	30-38		
	(Low-High)	CFM	600-670	1,060-1,350	1,060-1,350	
External pressure		Pa	0	0		
Sound level (Low-High)		dB(A)	34-38	44-50	44-50	
External finish			Stainless steel			
Dimension	W : mm	1136	1520	1520		
		D : mm	650	650		
	H : mm	280	280	280		
	W : inch	44-3/4	59-7/8	59-7/8		
		D : inch	25-5/8	25-5/8		
	H : inch	11	11	11		
Weight	kg	41	56	56		
	lbs	90	124	124		
Field drain pipe O.D.	mm	26	26	26		
	inch	1	1	1		
Outdoor unit	Air flow	CMM	60	120	120	
		CFM	2,120	4,230	4,230	
	Sound level at cooling		dB(A)	47	50	
	Sound level at heating		dB(A)	48	52	
	External finish			Ivory Munsell 3Y 7.8/1.1		
	Dimension	W : mm	950	1,050	1,050	
			D : mm	330+30	330+30	
		H : mm	943	1,338	1,338	
		W : inch	37-3/8	41-5/16	41-5/16	
			D : inch	13 + 1-3/16	13 + 1-3/16	
H : inch		37-1/8	52-11/16	52-11/16		
Weight	kg	67	116	126		
	lbs	148	256	278		
Refrigerant pipe size	Gas side O.D.	mm	15.88	15.88		
		inch	5/8	5/8		
	Liquid side O.D.	mm	9.52	9.52		
		inch	3/8	3/8		
Refrigerant pipe length	Height difference	m	Max. 30	Max. 30		
	Length	m	Max. 50	Max. 75		

NOTE: 1. Rating conditions (ISO T1)

Cooling Indoor: D.B. 27°C (80°F) W.B. 19°C (66°F) Outdoor: D.B. 35°C (95°F) W.B. 24°C (75°F)

Heating Indoor: D.B. 20°C (68°F) Outdoor: D.B. 7°C (45°F) W.B. 6°C (43°F)

Refrigerant piping length (one way): 5m (16ft.)

2. Guaranteed operating range

	Indoor		Outdoor
Cooling	Upper limit	D.B. 35°C, W.B. 22.5°C	D.B. 46°C
	Lower limit	D.B. 19°C, W.B. 15°C	D.B. -5°C
Heating	Upper limit	D.B. 28°C	D.B. 21°C, W.B. 15°C
	Lower limit	D.B. 17°C	D.B. -20°C, W.B. -20°C

3. Guaranteed voltage

198-264V, 50Hz (RP125Y: 342-457V, 50Hz)

4. Above data are based on the indicated voltage.

Indoor unit Single phase 230V 50Hz

Outdoor unit V: Single phase 230V 50Hz

Y: 3 phase 400V 50Hz

※ If optional air protect guide installed. D.B. -15°C

2-5. FLOOR STANDING TYPE

Model name	Indoor unit	PSA-RP71GA		
	Outdoor unit	PUHZ-RP71VHA4		
Cooling	Capacity	Btu/h	24,200	
		kW	7.1(3.3-8.1)	
	Total input	kW	2.20	
	EER		3.23	
	Energy label class		A	
Heating	Capacity	Btu/h	25,900	
		kW	7.6(3.5-10.2)	
	Total input	kW	2.23	
	COP		3.41	
	Energy label class		B	
Power supply	Booster heater	kW	-	
	Phase	φ	1	
	Cycle	Hz	50	
	Voltage	V	230	
	Breaker size	A	25	
Indoor unit	Air flow (Low-High)	CMM	15-18	
	External pressure	Pa	0	
	Sound level (Low-High)	dB(A)	40-45	
	External finish		White Munsell 0.70Y 8.59/0.97	
	Dimension	W : mm		600
		D : mm		270
		H : mm		1,900
		W : inch		23-5/8
		D : inch		10-5/8
		H : inch		74-13/16
	Weight	kg		43
		lbs		98
	Field drain pipe I. D.	mm		20
inch			13/16	
Outdoor unit	Air flow	CMM	60	
		CFM	2,120	
	Sound level at cooling	dB(A)	47	
	Sound level at heating	dB(A)	48	
	External finish		Ivory Munsell 3Y 7.8/1.1	
	Dimension	W : mm		950
		D : mm		330+30
		H : mm		943
		W : inch		37-3/8
		D : inch		13 + 1-3/16
H : inch			37-1/8	
Weight	kg		67	
	lbs		148	
Refrigerant pipe size	Gas side O.D.	mm	15.88	
		inch	5/8	
	Liquid side O.D.	mm	9.52	
		inch	3/8	
Refrigerant pipe length	Height difference	m	Max. 30	
	Length	m	Max. 50	

NOTE: 1. Rating conditions (ISO T1)

Cooling Indoor : D.B. 27°C (80°F) W.B. 19°C (66°F)

Heating Indoor : D.B. 20°C (68°F)

Refrigerant piping length (one way) : 5m (16ft.)

Outdoor : D.B. 35°C (95°F) W.B. 24°C (75°F)

Outdoor : D.B. 7°C (45°F) W.B. 6°C (43°F)

2. Guaranteed operating range

	Indoor		Outdoor	
Cooling	Upper limit	D.B. 35°C, W.B. 22.5°C	D.B. 46°C	
	Lower limit	D.B. 19°C, W.B. 15°C	D.B. -5°C	
Heating	Upper limit	D.B. 28°C	D.B. 21°C, W.B. 15°C	
	Lower limit	D.B. 17°C	D.B. -20°C, W.B. -20°C	

3. Guaranteed voltage

198~264V, 50Hz.

4. Above data are based on the indicated voltage.

Indoor unit Single phase 230V 50Hz

Outdoor unit Single phase 230V 50Hz

※ If optional air protect guide installed. D.B. -15°C

Model name	Indoor unit	PSA-RP100GA	PSA-RP125GA	PSA-RP140GA	
	Outdoor unit	PUHZ-RP100VKA	PUHZ-RP125VKA	PUHZ-RP140VKA	
Cooling	Capacity	Btu/h	34,100	42,300	47,100
		kW	10.0(4.9-11.4)	12.4(5.5-14.0)	13.8(6.2-15.3)
	Total input	kW	2.99	4.12	4.91
	EER		3.34	3.01	2.81
	Energy label class		A	B	C
Heating	SHF		0.81	0.75	0.74
		Capacity	Btu/h	38,200	47,800
		kW	11.2(4.5-14.0)	14.0(5.0-16.0)	16.0(5.7-18.0)
	Total input	kW	3.28	4.11	4.97
	COP		3.41	3.41	3.22
	Energy label class		B	B	C
Power supply	Booster heater	kW	-	-	-
	Phase	φ		1	
	Cycle	Hz		50	
	Voltage	V		230	
Indoor unit	Breaker size	A	32	40	
	Air flow	CMM	24-31	26-33	27-35
		CFM	850-1060	920-1165	955-1240
	External pressure	Pa	0		
	Sound level (Low-High)	dB(A)	44-49	46-51	47-52
	External finish		White Munsell 0.70Y 8.59/0.97		
	Dimension	W : mm	600		
		D : mm	350		
		H : mm	1,900		
		W : inch	23-5/8		
		D : inch	13-3/4		
		H : inch	74-13/16		
	Weight	kg	51		53
lbs		112		117	
Field drain pipe I.D.	mm	20			
	inch	13/16			
Outdoor unit	Air flow	CMM	110	120	
		CFM	3,880	4,230	
	Sound level at cooling	dB(A)	49	50	
	Sound level at heating	dB(A)	51	52	
	External finish		Ivory Munsell 3Y 7.8/1.1		
	Dimension	W : mm	1,050		
D : mm		330+30			
H : mm		1,338			
W : inch		41-5/16			
D : inch		13 + 1-3/16			
H : inch		52-11/16			
Weight	kg	116		119	
	lbs	256		262	
Refrigerant pipe size	Gas side O.D.	mm	15.88		
		inch	5/8		
	Liquid side O.D.	mm	9.52		
		inch	3/8		
Refrigerant pipe length	Height difference	m	Max. 30		
	Length	m	Max. 75		

NOTE: 1. Rating conditions (ISO T1)

Cooling Indoor : D.B. 27°C (80°F) W.B. 19°C (66°F)

Outdoor : D.B. 35°C (95°F) W.B. 24°C (75°F)

Heating Indoor : D.B. 20°C (68°F)

Outdoor : D.B. 7°C (45°F) W.B. 6°C (43°F)

Refrigerant piping length (one way) : 5m (16ft.)

2. Guaranteed operating range

		Indoor	Outdoor
Cooling	Upper limit	D.B. 35°C, W.B. 22.5°C	D.B. 46°C
	Lower limit	D.B. 19°C, W.B. 15°C	D.B. -5°C ※
Heating	Upper limit	D.B. 28°C	D.B. 21°C, W.B. 15°C
	Lower limit	D.B. 17°C	D.B. -20°C, W.B. -20°C

3. Guaranteed voltage

198-264V, 50Hz

4. Above data are based on the indicated voltage.

Indoor unit Single phase 230V 50Hz

Outdoor unit Single phase 230V 50Hz

※ If optional air protect guide installed. D.B. -15°C

Model name	Indoor unit		PSA-RP100GA	PSA-RP125GA	PSA-RP140GA		
	Outdoor unit		PUHZ-RP100YKA	PUHZ-RP125YKA	PUHZ-RP140YKA		
Cooling	Capacity	Btu/h	34,100	42,300	47,100		
		kW	10.0(4.9-11.4)	12.4(5.5-14.0)	13.8(6.2-15.3)		
	Total input	kW	2.99	4.12	4.91		
	EER		3.34	3.01	2.81		
	Energy label class		A	B	C		
Heating	Capacity	Btu/h	38,200	47,800	54,600		
		kW	11.2(4.5-14.0)	14.0(5.0-16.0)	16.0(5.7-18.0)		
	Total input	kW	3.28	4.11	4.97		
	COP		3.41	3.41	3.22		
	Energy label class		B	B	C		
Power supply	Booster heater	kW	-	-	-		
	Phase	φ		3			
	Cycle	Hz		50			
	Voltage	V		400			
Indoor unit	Breaker size	A	16				
	Air flow (Low-High)	CMM	24-31	26-33	27-35		
		CFM	850-1,060	920-1,165	955-1,240		
	External pressure	Pa	0				
	Sound level (Low-High)	dB(A)	44-49	46-51	47-52		
			External finish				
			White Munsell 0.70Y 8.59/0.97				
	Dimension	W : mm	600				
			350				
			1,900				
			W : inch	23-5/8			
				13-3/4			
			H : inch	74-13/16			
	Weight	kg		51	51	53	
		lbs	112	112	117		
Field drain pipe I.D.	mm	20					
	inch	13/16					
Outdoor unit	Air flow	CMM	110	120			
		CFM	3,880	4,230			
	Sound level at cooling	dB(A)	49	50			
			51	52			
	Sound level at heating	dB(A)	51	52			
			External finish				
			Ivory Munsell 3Y 7.8/1.1				
	Dimension	W : mm	1,050				
			330+30				
			1,338				
W : inch			41-5/16				
			13 + 1-3/16				
H : inch			52-11/16				
	Weight	kg	124	126	132		
lbs		273	278	291			
Refrigerant pipe size	Gas side O.D.	mm	15.88				
		inch	5/8				
	Liquid side O.D.	mm	9.52				
		inch	3/8				
Refrigerant pipe length	Height difference	m	Max. 30				
	Length	m	Max. 75				

NOTE: 1. Rating conditions (ISO T1)

Cooling Indoor: D.B. 27°C (80°F) W.B. 19°C (66°F) Outdoor: D.B. 35°C (95°F) W.B. 24°C (75°F)
 Heating Indoor: D.B. 20°C (68°F) Outdoor: D.B. 7°C (45°F) W.B. 6°C (43°F)
 Refrigerant piping length (one way): 5m (16ft.)

2. Guaranteed operating range

		Indoor	Outdoor
Cooling	Upper limit	D.B. 35°C, W.B. 22.5°C	D.B. 46°C
	Lower limit	D.B. 19°C, W.B. 15°C	D.B. -5°C ※
Heating	Upper limit	D.B. 28°C	D.B. 21°C, W.B. 15°C
	Lower limit	D.B. 17°C	D.B. -20°C, W.B. -20°C

3. Guaranteed voltage

Indoor unit 198-264V, 50Hz
 Outdoor unit 342-457V, 50Hz

4. Above data are based on the indicated voltage.

Indoor unit Single phase 230V 50Hz
 Outdoor unit 3 phase 400V 50Hz

※ If optional air protect guide installed. D.B. -15°C

PEAD-RP35, 50, 60, 71, 100, 125, 140JA

Unit : mm

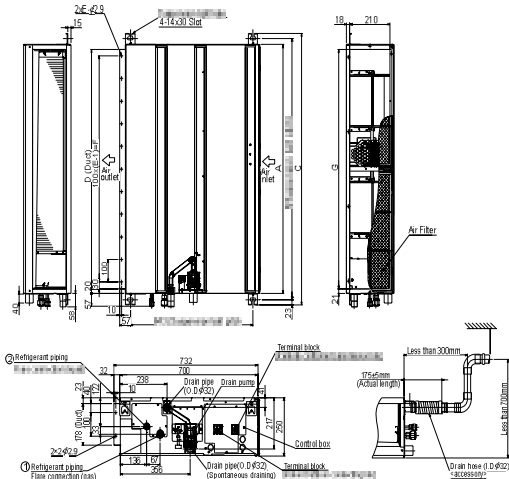

1. El modelo PEAD-RP35, 50JA y PEAD-RP60, 71JA tienen un filtro de carbón activo. Los modelos PEAD-RP100, 125JA y PEAD-RP140JA tienen un filtro de carbón activo y un filtro HEPA. El modelo PEAD-RP100, 125JA y PEAD-RP140JA tienen un filtro HEPA. El modelo PEAD-RP100, 125JA y PEAD-RP140JA tienen un filtro HEPA. El modelo PEAD-RP100, 125JA y PEAD-RP140JA tienen un filtro HEPA.

Model	A	B	C	D	E	F	G	G (Gas pipe)	L (Liquid pipe)
PEAD-RP35,50JA	800	954	1000	880	9	800	858	φ 12.7	φ 6.35
PEAD-RP60,71JA	1100	1154	1200	1060	11	1000	1058		
PEAD-RP100,125JA	1400	1454	1500	1380	14	1300	1358	φ 15.88	φ 9.52
PEAD-RP140JA	1900	1954	1700	1580	18	1500	1558		

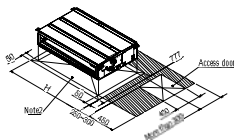
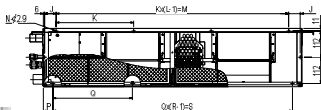
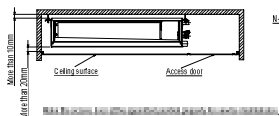

Model	H	I	K	L	M	N	P	Q	R
PEAD-RP35,50JA	1000	94	1000	4	1000	10	40	340	4
PEAD-RP60,71JA	1200	49	1200	4	990	10	40	340	4
PEAD-RP100,125JA	1500	54	1500	5	1280	12	40	380	5
PEAD-RP140JA	1900	54	1700	5	1480	12	40	380	5

REGAR SUJETAR EN ESTOS PUNTOS

PEAD-RP35, 50, 60, 71, 100, 125, 140JAL

Unit : mm

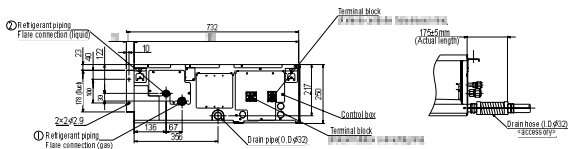
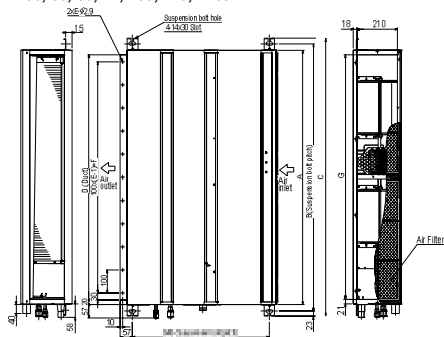

- NOTES: 1. The dimensions refer to the standard model.
 2. The dimensions refer to the standard model.
 3. The dimensions refer to the standard model.
 4. The dimensions refer to the standard model.
 5. The dimensions refer to the standard model.
 6. The dimensions refer to the standard model.
 7. The dimensions refer to the standard model.
 8. The dimensions refer to the standard model.
 9. The dimensions refer to the standard model.
 10. The dimensions refer to the standard model.

Model	A	B	C	D	E	F	G	① Gas pipe	② Liquid pipe
PEAD-RP35,50JAL	900	954	1000	860	9	800	858	φ 12.7	φ 6.35
PEAD-RP60,71JAL	1100	1154	1200	1080	11	1000	1058		
PEAD-RP100,125JAL	1400	1454	1500	1380	14	1300	1358	φ 15.88	φ 9.52
PEAD-RP140JAL	1600	1654	1700	1580	16	1500	1558		

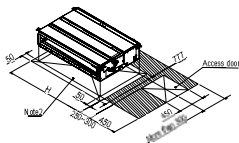
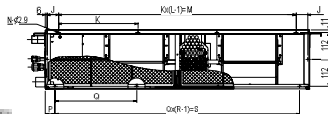
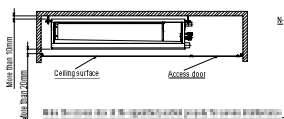

Model	H	I	J	K	L	M	N	P	Q	R
PEAD-RP35,50JAL	1000	90	100	10	100	10	10	10	10	819
PEAD-RP60,71JAL	1200	90	100	10	100	10	10	10	10	1000
PEAD-RP100,125JAL	1500	90	100	10	100	10	10	10	10	1300
PEAD-RP140JAL	1700	90	100	10	100	10	10	10	10	1500

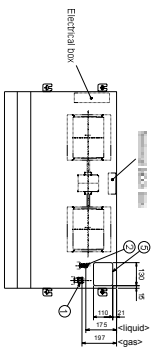

- ① High-pressure liquid refrigerant piping, suspended (structure: 1.41 inch)
- ② Refrigerant piping (suspended) from suspended (structure: 1.41 inch)
- ③ High-pressure liquid refrigerant piping (structure: 1.41 inch)
- ④ High-pressure liquid refrigerant piping (structure: 1.41 inch)
- ⑤ High-pressure liquid refrigerant piping (structure: 1.41 inch)
- ⑥ High-pressure liquid refrigerant piping (structure: 1.41 inch)
- ⑦ High-pressure liquid refrigerant piping (structure: 1.41 inch)
- ⑧ High-pressure liquid refrigerant piping (structure: 1.41 inch)
- ⑨ High-pressure liquid refrigerant piping (structure: 1.41 inch)

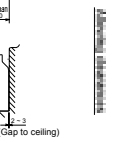
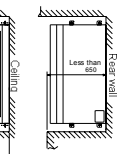
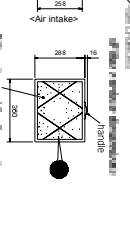
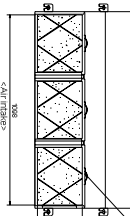
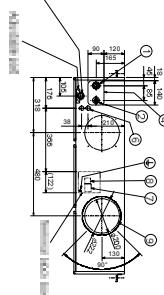
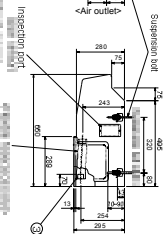
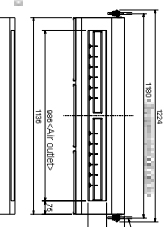
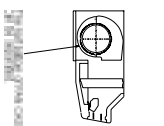

NOTES
1. The unit is not to be installed on a ceiling.

Unit : mm

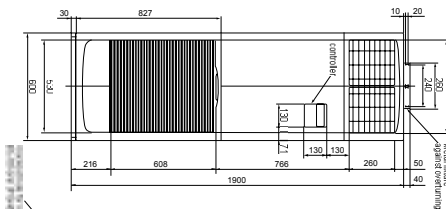
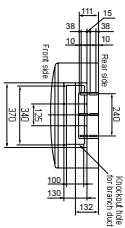

Knockout hole for branch duct



Knockout hole for wiring Ø27

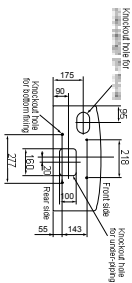

VIEW A

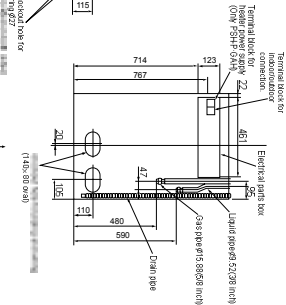

Knockout hole for wiring Ø27

A

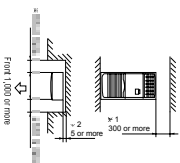
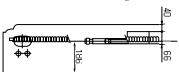

※ 1. Knockout hole for branch duct
※ 2. Adjustable

PSA-RP71GA

Unit : mm

PSA-RP100GA
PSA-RP125GA
PSA-RP140GA

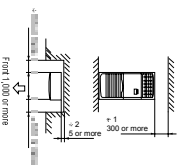
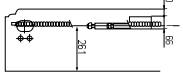
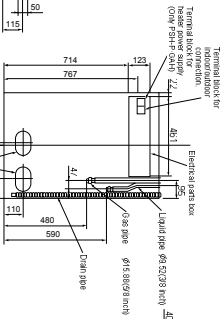
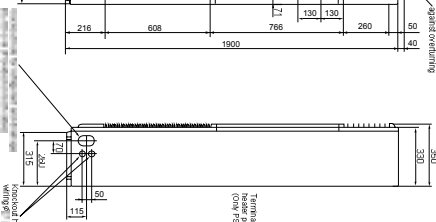
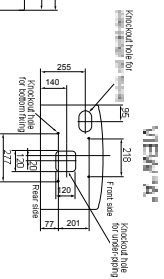
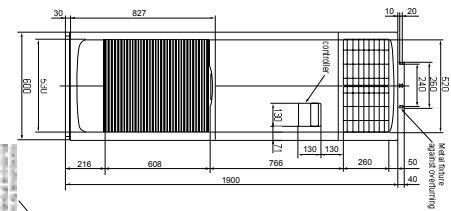
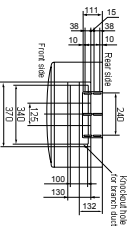

✕ 1 Adjustable
✕ 2 Adjustable

A

Unit : mm

PUHZ-RP35VHA4 PUHZ-RP50VHA4

Unit : mm

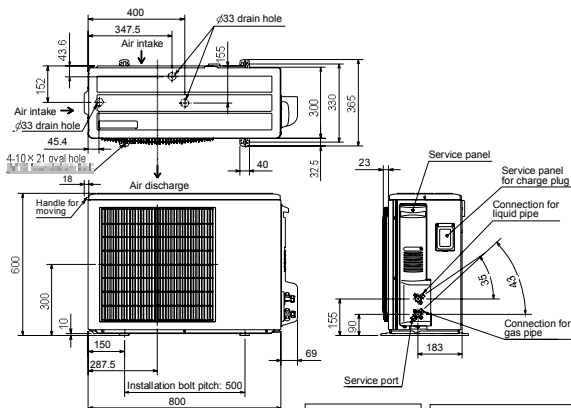

Free space around the outdoor unit (basic example)

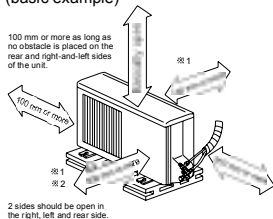

Minimum installation space for outdoor unit

- Ⓐ In the place where short cycle tends to occur, cooling and heating capacity and power consumption might get lowered by 10%. Air outlet guide (optional PAC-SG585G) will help them improve.
- Ⓑ If air discharges to the wall, the surface might get stained.

1. PREPARATION

Please secure the unit firmly with 4 foundation (M10) bolts. (Bolts, washer and nut must be purchased locally.)



2. PIPING AND WIRING CONNECTION

Piping and wiring connection can be made from the rear direction only.

3. ATTACHING THE CONDUIT

In order to attach the conduit, it is necessary to fix the metal plate with 2 screws to the back panel. Procure the metal plate and make screw holes locally. It is recommended to use the metal plate shown below. Align the metal plate to the marks on the unit and attach it.

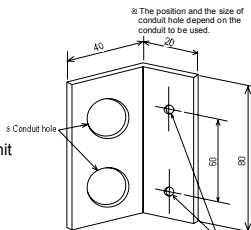

Unit : mm

WIRELESS REMOTE CONTROLLER

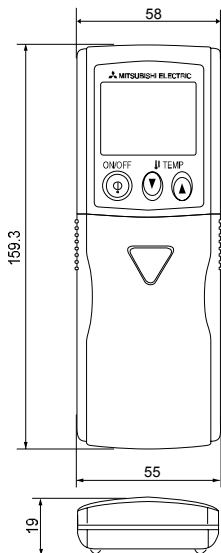

WIRED REMOTE CONTROLLER

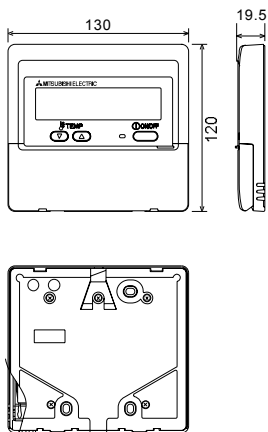

PEA-RP200, 250GA

INDOOR UNIT	SYMBOL	NAME
	MF1	FAN MOTOR
	51F	FUSE
	49F	FUSE
	TR2-4.5	TERMINAL BLOCK
	TH1	ROOM TEMP
	TH2	LIQUID PIPE TEMP
	TH5	COND/EA TEMP
	X1	AUXILIARY RELAY
	CR1-2	SURGE KILLER
	FR	FERRITE CORE
	FUSE	FUSE
	ZNR	VARIABLE
	SW1	SWITCH
	SW2	SWITCH
	SW3	SWITCH
	SW4	SWITCH
	SW5	SWITCH
	SW6	SWITCH
	SW7	SWITCH
	SW8	SWITCH
	SW9	SWITCH
	SW10	SWITCH
	SW11	SWITCH
	SW12	SWITCH
	SW13	SWITCH
	SW14	SWITCH
	SW15	SWITCH
	SW16	SWITCH
	SW17	SWITCH
	SW18	SWITCH
	SW19	SWITCH
	SW20	SWITCH
	SW21	SWITCH
	SW22	SWITCH
	SW23	SWITCH
	SW24	SWITCH
	SW25	SWITCH
	SW26	SWITCH
	SW27	SWITCH
	SW28	SWITCH
	SW29	SWITCH
	SW30	SWITCH
	SW31	SWITCH
	SW32	SWITCH
	SW33	SWITCH
	SW34	SWITCH
	SW35	SWITCH
	SW36	SWITCH
	SW37	SWITCH
	SW38	SWITCH
	SW39	SWITCH
	SW40	SWITCH
	SW41	SWITCH
	SW42	SWITCH
	SW43	SWITCH
	SW44	SWITCH
	SW45	SWITCH
	SW46	SWITCH
	SW47	SWITCH
	SW48	SWITCH
	SW49	SWITCH
	SW50	SWITCH
	SW51	SWITCH
	SW52	SWITCH
	SW53	SWITCH
	SW54	SWITCH
	SW55	SWITCH
	SW56	SWITCH
	SW57	SWITCH
	SW58	SWITCH
	SW59	SWITCH
	SW60	SWITCH
	SW61	SWITCH
	SW62	SWITCH
	SW63	SWITCH
	SW64	SWITCH
	SW65	SWITCH
	SW66	SWITCH
	SW67	SWITCH
	SW68	SWITCH
	SW69	SWITCH
	SW70	SWITCH
	SW71	SWITCH
	SW72	SWITCH
	SW73	SWITCH
	SW74	SWITCH
	SW75	SWITCH
	SW76	SWITCH
	SW77	SWITCH
	SW78	SWITCH
	SW79	SWITCH
	SW80	SWITCH
	SW81	SWITCH
	SW82	SWITCH
	SW83	SWITCH
	SW84	SWITCH
	SW85	SWITCH
	SW86	SWITCH
	SW87	SWITCH
	SW88	SWITCH
	SW89	SWITCH
	SW90	SWITCH
	SW91	SWITCH
	SW92	SWITCH
	SW93	SWITCH
	SW94	SWITCH
	SW95	SWITCH
	SW96	SWITCH
	SW97	SWITCH
	SW98	SWITCH
	SW99	SWITCH
	SW100	SWITCH
	SW101	SWITCH
	SW102	SWITCH
	SW103	SWITCH
	SW104	SWITCH
	SW105	SWITCH
	SW106	SWITCH
	SW107	SWITCH
	SW108	SWITCH
	SW109	SWITCH
	SW110	SWITCH
	SW111	SWITCH
	SW112	SWITCH
	SW113	SWITCH
	SW114	SWITCH
	SW115	SWITCH
	SW116	SWITCH
	SW117	SWITCH
	SW118	SWITCH
	SW119	SWITCH
	SW120	SWITCH
	SW121	SWITCH
	SW122	SWITCH
	SW123	SWITCH
	SW124	SWITCH
	SW125	SWITCH
	SW126	SWITCH
	SW127	SWITCH
	SW128	SWITCH
	SW129	SWITCH
	SW130	SWITCH
	SW131	SWITCH
	SW132	SWITCH
	SW133	SWITCH
	SW134	SWITCH
	SW135	SWITCH
	SW136	SWITCH
	SW137	SWITCH
	SW138	SWITCH
	SW139	SWITCH
	SW140	SWITCH
	SW141	SWITCH
	SW142	SWITCH
	SW143	SWITCH
	SW144	SWITCH
	SW145	SWITCH
	SW146	SWITCH
	SW147	SWITCH
	SW148	SWITCH
	SW149	SWITCH
	SW150	SWITCH
	SW151	SWITCH
	SW152	SWITCH
	SW153	SWITCH
	SW154	SWITCH
	SW155	SWITCH
	SW156	SWITCH
	SW157	SWITCH
	SW158	SWITCH
	SW159	SWITCH
	SW160	SWITCH
	SW161	SWITCH
	SW162	SWITCH
	SW163	SWITCH
	SW164	SWITCH
	SW165	SWITCH
	SW166	SWITCH
	SW167	SWITCH
	SW168	SWITCH
	SW169	SWITCH
	SW170	SWITCH
	SW171	SWITCH
	SW172	SWITCH
	SW173	SWITCH
	SW174	SWITCH
	SW175	SWITCH
	SW176	SWITCH
	SW177	SWITCH
	SW178	SWITCH
	SW179	SWITCH
	SW180	SWITCH
	SW181	SWITCH
	SW182	SWITCH
	SW183	SWITCH
	SW184	SWITCH
	SW185	SWITCH
	SW186	SWITCH
	SW187	SWITCH
	SW188	SWITCH
	SW189	SWITCH
	SW190	SWITCH
	SW191	SWITCH
	SW192	SWITCH
	SW193	SWITCH
	SW194	SWITCH
	SW195	SWITCH
	SW196	SWITCH
	SW197	SWITCH
	SW198	SWITCH
	SW199	SWITCH
	SW200	SWITCH
	SW201	SWITCH
	SW202	SWITCH
	SW203	SWITCH
	SW204	SWITCH
	SW205	SWITCH
	SW206	SWITCH
	SW207	SWITCH
	SW208	SWITCH
	SW209	SWITCH
	SW210	SWITCH
	SW211	SWITCH
	SW212	SWITCH
	SW213	SWITCH
	SW214	SWITCH
	SW215	SWITCH
	SW216	SWITCH
	SW217	SWITCH
	SW218	SWITCH
	SW219	SWITCH
	SW220	SWITCH
	SW221	SWITCH
	SW222	SWITCH
	SW223	SWITCH
	SW224	SWITCH
	SW225	SWITCH
	SW226	SWITCH
	SW227	SWITCH
	SW228	SWITCH
	SW229	SWITCH
	SW230	SWITCH
	SW231	SWITCH
	SW232	SWITCH
	SW233	SWITCH
	SW234	SWITCH
	SW235	SWITCH
	SW236	SWITCH
	SW237	SWITCH
	SW238	SWITCH
	SW239	SWITCH
	SW240	SWITCH
	SW241	SWITCH
	SW242	SWITCH
	SW243	SWITCH
	SW244	SWITCH
	SW245	SWITCH
	SW246	SWITCH
	SW247	SWITCH
	SW248	SWITCH
	SW249	SWITCH
	SW250	SWITCH
	SW251	SWITCH
	SW252	SWITCH
	SW253	SWITCH
	SW254	SWITCH
	SW255	SWITCH
	SW256	SWITCH
	SW257	SWITCH
	SW258	SWITCH
	SW259	SWITCH
	SW260	SWITCH
	SW261	SWITCH
	SW262	SWITCH
	SW263	SWITCH
	SW264	SWITCH
	SW265	SWITCH
	SW266	SWITCH
	SW267	SWITCH
	SW268	SWITCH
	SW269	SWITCH
	SW270	SWITCH
	SW271	SWITCH
	SW272	SWITCH
	SW273	SWITCH
	SW274	SWITCH
	SW275	SWITCH
	SW276	SWITCH
	SW277	SWITCH
	SW278	SWITCH
	SW279	SWITCH
	SW280	SWITCH
	SW281	SWITCH
	SW282	SWITCH
	SW283	SWITCH
	SW284	SWITCH
	SW285	SWITCH
	SW286	SWITCH
	SW287	SWITCH
	SW288	SWITCH
	SW289	SWITCH
	SW290	SWITCH
	SW291	SWITCH
	SW292	SWITCH
	SW293	SWITCH
	SW294	SWITCH
	SW295	SWITCH
	SW296	SWITCH
	SW297	SWITCH
	SW298	SWITCH
	SW299	SWITCH
	SW300	SWITCH

REMOTE CONTROLLER	SYMBOL	NAME
	TE5	REMOTE CONTROLLER
	TE6	TERMINAL BLOCK

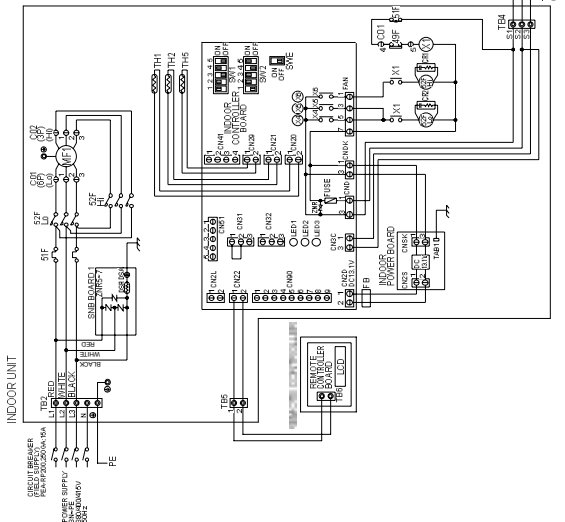

PKA-RP35HAL PKA-RP50HAL

[Explanation of symbols]

Symbol	Name	Symbol	Name
I.B	Indoor controller board	M	Ylave motor
CN2L	Connector (LOSSNAV)	MS	Fan motor
CN32	Connector (Remote switch)	S.W	Switch board
CN41	Connector (HA terminal/A)	SWE2	Emergency operation
CN51	Connector (Centrally control)	TB2	Terminal block (Indoor unit Power (option))
CN60	Connector (Remote operation adapter)	TB4	Terminal block (Indoor/outdoor connecting line)
FUSE	FUSE (13.15A/250V)	TB5	Room temp. Thermistor (0°C/19kΩ, 25°C/5.4kΩ Detect)
LED1	Power supply (L.B)	TH1	Room temp. Thermistor/liquid (0°C/19kΩ, 25°C/5.4kΩ Detect)
LED2	Power supply (R.B)	TH2	Pipe temp. Thermistor/liquid (0°C/19kΩ, 25°C/5.4kΩ Detect)
LED3	Transmission (Indoor-outdoor)	TH5	Cond.leva. temp. Thermistor (0°C/19kΩ, 25°C/5.4kΩ Detect)
SW1	Switch (Model selection) ¹⁾ See table 1	WB	Pub for wireless remote controller
SW2	Switch (Capacity code) ²⁾ See table 2	LED1	LED (Operation indication - Green)
SWE	Connector (Emergency operation)	LED2	LED (Preparation for heating - Orange)
XB	Relay (Drain pump) (option)	REC1	Receiving unit
CNP	Drain pump (option) power supply (Drain pump (option))	REACTOR	REACTOR
CN4F	Drain float switch (Drain pump (option))	DP	DRAIN PUMP (OPTION)
R.B	Wired remote controller(option)	FS	DRAIN FLOAT SWITCH (OPTION)
TB6	Terminal block (Remote controller transmission line)		

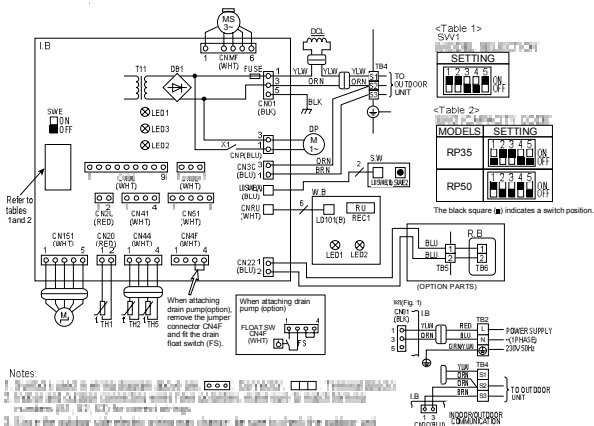

Notes:

- 1) Symbol 1) used in this diagram shows an Terminal block
 - 2) Model and Capacity code combination used for indoor unit is shown in the following table.
 - 3) Use the outdoor unit which is same as shown in the table for the outdoor unit and wiring wiring diagram for service.
 - 4) This diagram shows the a case of indoor and outdoor connecting wires. If used indoor of 230V, please use 230V/50Hz power for power supply.
- ※ If model and capacity code is not included in the above table, refer to Fig. 1.
※ For other wiring system (230V and 115V) in the outdoor unit, please refer to the manual.

PKA-RP60KAL PKA-RP71KAL PKA-RP100KAL

[LEGEND]

SYMBOL	NAME	SYMBOL	NAME
IB	Indoor controller board	M	Vane motor
CN2L	Connector (LOSSNAY)	MS	Fan motor
CN32	Connector (Remote switch)	S.W	Switch board
CN41	Connector (HA terminal-A)	SWE2	Emergency operation
CN51	Connector (Centrally control)	TB2	Terminal block (Indoor unit Power (option))
CN90	Connector (Remote operation adapter)	TB4	Terminal block (Indoor/outdoor connecting line)
FUSE	FUSE (T3 15A/250V)	TB5	Terminal block (Remote controller transmission line)
LED1	Power supply (LB)	TH1	Room temp. Thermistor (0°C / 15kΩ, 25°C / 5.4kΩ Detect)
LED2	Power supply (RB)	TH2	Pipe temp. Thermistor/liquid (0°C / 15kΩ, 25°C / 5.4kΩ Detect)
LED3	Transmission (Indoor-outdoor)	TH5	Cond. / eva. temp. Thermistor (0°C / 15kΩ, 25°C / 5.4kΩ Detect)
SW1	Switch (Model selection) (See table 1)	WB	Box for wireless remote controller
SW2	Switch (Capacity code) (See table 2)	LED1	LED (Operation indication - Green)
SWE	Connector (Emergency operation)	LED2	LED (Preparation for heating - Orange)
X1	Relay (Drain pump(option))	REC1	Receiving unit
CNP	Drain pump (option) power supply (Sold separately/Drain pump(option))	DCL	REACTOR
CN4F	Drain pump (option) Drain pump relay (option)	DP	DRAIN PUMP (OPTION)
R.B	Wired remote controller	FS	DRAIN FLOAT SWITCH (OPTION)
TB6	Terminal block (Remote controller transmission line)		

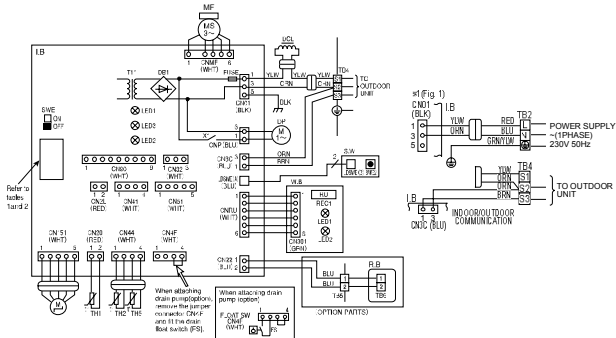

(Table 1)

SW1 MODEL SELECTION



(Table 2)

SW2 (CAPACITY CODE)



The black square (■) indicates a switch position.

Notes:

1. Symbols used in wiring diagrams above are: []: Connector, []: Terminal Block.
2. Indoor and outdoor air conditioning units for the positions, (room temperature) terminal block (TB1, TB2, TB3) for capacity setting.
3. Since the indicator is also used for other models, be sure to check the outdoor unit, etc. etc. wiring diagrams for servicing.
4. It is suggested that the wiring of indoor and outdoor connecting wires (specification of JIS) be installed separately for power and signal.
- ※ If indoor and outdoor units are not compatible (same capacity), refer to Fig. 1.
- ※ For a power supply system of the unit, refer to the installation manual provided as an accessory.

PCA-RP50KA PCA-RP60KA PCA-RP71KA
PCA-RP100KA PCA-RP125KA PCA-RP140KA

(LEGEND)

SYMBOL	NAME	SYMBOL	NAME
IB	INDOOR CONTROLLER BOARD	TB	TERMINAL BLOCK (INDOOR/OUTDOOR CONNECTING LINE)
CBUL	CONNECTOR (LOSSYAT)	TB5	TERMINAL BLOCK (REMOTE CONTROLLER TRANSMISSION LINE)
CBNS	CONNECTOR (REMOTE SWITCH)	TR	ROOM TEMP. THERMISTOR
CBNT	CONNECTOR (ON-TERMINAL A)	TR1	ROOM TEMP. THERMISTOR (6°C / 19°C / 25°C / 5.4°C DETECT)
CBNS1	CONNECTOR (CENTRAL CONTROL)	TR2	PIPE TEMP. THERMISTOR (LQ) (6°C / 19°C / 25°C / 5.4°C DETECT)
FUSE	FUSE (B 3AL 250V)	TR3	COND./EVA. TEMP. THERMISTOR (6°C / 19°C / 25°C / 5.4°C DETECT)
LE2F	POWER SUPPLY (L.B)		
LE2S	POWER SUPPLY (R.B)		
LE2B	TRANSMISSION (INDOOR-OUTDOOR)		
SW1	SWITCH (MODEL SELECTION) (Size 100-1)		
SW2	SWITCH (CAPACITY CODE) (Size 100-2)		
SW3	CONNECTOR (EMERGENCY OPERATION)		
AT	IR EYE (ASIAN FRAME)		
R.S	IR EYE (REMOTE CONTROLLER BOARD)		
DCL	REACTOR		
MF	FAN MOTOR		
MY	WAVE MOTOR		
TB2			

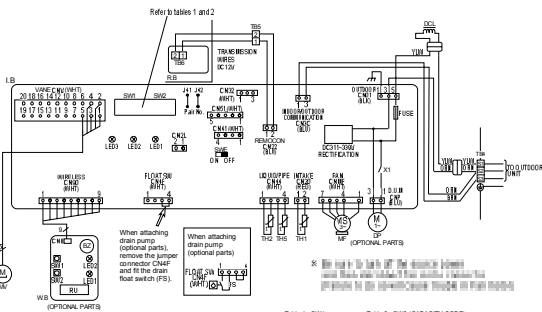

* When used in the heat OFF (heat rejection) operation, connect block with outdoor unit through a capacitor (for protection for the indoor-capacitor through the air filter mechanism)

<Table 1> SW1 (MODEL SELECTION)

SW1	Service
1	OFF
2	ON

<Table 2> SW2 (CAPACITY CODE)

SW2	Service		
	Indicate	Indicate	Service
KA:RP:50	ON	OFF	Indicate (ON)
KA:RP:60	ON	OFF	Indicate (ON)
KA:RP:71	ON	OFF	Indicate (ON)
KA:RP:100	ON	OFF	Indicate (ON)
KA:RP:125	ON	OFF	Indicate (ON)
KA:RP:140	ON	OFF	Indicate (ON)

The black square (■) indicates a switch position.

Notes

1. Before connecting with the outdoor unit, please refer to the outdoor unit manual (Book).
2. Indoor unit should be connected to the outdoor unit by the connecting line. The connecting line should be connected to the outdoor unit by the connecting line.
3. Before connecting with the outdoor unit, please refer to the outdoor unit manual (Book).
4. The connecting line should be connected to the outdoor unit by the connecting line.
5. The connecting line should be connected to the outdoor unit by the connecting line.
6. The connecting line should be connected to the outdoor unit by the connecting line.
7. The connecting line should be connected to the outdoor unit by the connecting line.
8. The connecting line should be connected to the outdoor unit by the connecting line.
9. The connecting line should be connected to the outdoor unit by the connecting line.
10. The connecting line should be connected to the outdoor unit by the connecting line.

* If the indoor unit is used in the heat rejection operation, refer to Fig. 1.
* If the indoor unit is used in the heat rejection operation, refer to Fig. 1.

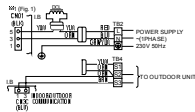

PCA-RP71HA PCA-RP125HA

(LEGEND)

SYMBOL	INDOOR	OUTDOOR	NAME
P.B	INDOOR POWER BOARD	MF1, MF2	FAN MOTOR
I.B	INDOOR CONTROLLER BOARD	C1, C2	CAPACITOR(FAN MOTOR)
FUSE	FUSE (T6.3AL250V)	H2	DEW PREVENTION HEATER
CN2L	CONNECTOR (LOSSNAY)	TB2	TERMINAL BLOCK(INDOOR UNIT POWER (OPTION))
CN32	CONNECTOR (REMOTE SWITCH)	TB4	TERMINAL BLOCK(INDOOR/OUTDOOR CONNECTING LINE)
CN41	CONNECTOR (HA TERMINAL-A)	TB5, TB6	TERMINAL BLOCK(REMOTE CONTROLLER TRANSMISSION LINE)
CN51	CONNECTOR (LOSSNAY)	TH1	ROOM TEMP.THERMISTOR (0°C/15kΩ, 25°C/5.4kΩ DETECT)
LED1	POWER SUPPLY (I.B)	TH2	PIPE TEMP.THERMISTOR/LIQUID (0°C/15kΩ, 25°C/5.4kΩ DETECT)
LED2	POWER SUPPLY (R.B)	TH5	COND./EVA.TEMP.THERMISTOR (0°C/15kΩ, 25°C/5.4kΩ DETECT)
LED3	TRANSMISSION(INDOOR-OUTDOOR)	R.B	WIRED REMOTE CONTROLLER BOARD
X1	RELAY (DEW PREVENTION HEATER)		
X4	RELAY (FAN MOTOR)		
X5	RELAY (FAN MOTOR)		
X6	RELAY (FAN MOTOR)		
SW1	SWITCH (EMERGENCY OPERATION)		
SW2	SWITCH (EMERGENCY OPERATION)		
SWE	SWITCH (EMERGENCY OPERATION)		

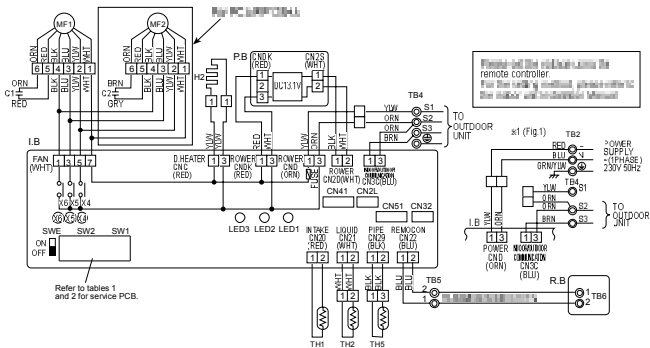

Please cut the connecting wires to remote controller. For the cutting method, please refer to the indoor and outdoor manual.

Table 1

SW1			
Service board			
1	2	3	4
ON	OFF	ON	OFF

Table 2

SW2			
MODELS	Service board	MODELS	Service board
PCA-RP71HA	1 2 3 4 5	PCA-RP125HA	1 2 3 4 5
	ON OFF		ON OFF

The black square (■) indicates a switch position.

Notes:

1. Symbols used in wiring diagram above are, □: Connector, ⊙: Terminal (block).
2. Indoor and outdoor connecting wires have polarities, make sure to match terminal numbers (S1, S2, S3) for correct wirings.
3. Since the outdoor side electric wiring may change, be sure to check the outdoor unit electric wiring diagram for servicing.
4. This diagram shows the wiring of indoor and outdoor connecting wires (specification of 230V), adopting superimposed system for power and signal.

※1: When supplying power separately to indoor and outdoor units, refer to Fig. 1.

※2: For power supply system of this unit, refer to the caution label located near this diagram.

PSA-RP71GA PSA-RP100GA PSA-RP125GA PSA-RP140GA

LEGEND

MODEL	NAME	MODEL	NAME	MODEL	NAME
P.B	INDOOR POWER BOARD	B SW1	RELAY (LOUVER)	C	CAPACITOR (FAN MOTOR)
I.B	INDOOR CONTROLLER BOARD	B SW2	RELAY (FAN MOTOR)	MF	FAN MOTOR
FUSE	FUSE (T6.3A/250V)	SWE	RELAY (LOUVER)	ML	LOUVER MOTOR
CN2L	CONNECTOR (LOSSNAY)	X2	RELAY (LOUVER)	TB2	TERMINAL BLOCK (FOR REMOTE CONTROLLER)
CN32	CONNECTOR (REMOTE SWITCH)	X4	RELAY (FAN MOTOR)	TB4	TERMINAL BLOCK (FOR REMOTE CONTROLLER)
CN41	CONNECTOR (HA TERMINAL-A)	X5	RELAY (FAN MOTOR)	TH1	HEATER THERMAL SWITCH (0°C/15K, 25°C/5.4K DETECT)
CN51	CONNECTOR (HA TERMINAL-B)	X6	RELAY (FAN MOTOR)	TH2	HEATER THERMAL SWITCH (0°C/15K, 25°C/5.4K DETECT)
LED1	POWER SUPPLY (L.B)	R.B	RELAY (FAN MOTOR)	TH5	HEATER THERMAL SWITCH (0°C/15K, 25°C/5.4K DETECT)
LED2	POWER SUPPLY (R.B)	TB6	TERMINAL BLOCK (FOR REMOTE CONTROLLER)		
LED3	POWER SUPPLY (I.B)				
		HEATER			
		FS1.2	THERMAL FUSE (110°C/16A)		
		H	HEATER		
		26H	HEATER THERMAL SWITCH		
		88H	HEATER CONTACTOR		

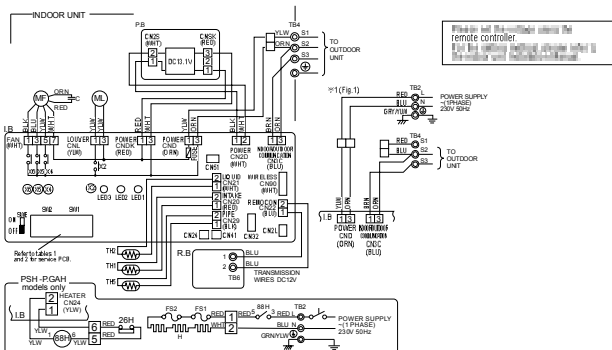

Table 1

MODELS	Service board
PSA-RP71GA PSH-P71GAH	

Table 2

MODELS	Service board
PSA-RP100GA PSH-P100GAH	
PSA-RP125GA PSH-P125GAH	
PSA-RP140GA PSH-P140GAH	

The black square (■) indicates a switch position.

Notes:

- Symbols used in wiring diagram above are, Connector, Terminal (block).
- Indoor and outdoor connecting wires have polarities, make sure to match terminal numbers (S1, S2, S3) for correct wirings.
- Since the outdoor side electric wiring may change, be sure to check the outdoor unit electric wiring diagram for servicing.
- This diagram shows the wiring of indoor and outdoor connecting wires (specification of 230V), adopting superimposed system for power and signal.
 - *1: When supplying power separately to indoor and outdoor units, refer to Fig. 1.
 - *2: For power supply system of this unit, refer to the caution label located near this diagram.

4-2. OUTDOOR UNIT PUHZ-RP35VHA4 PUHZ-RP50VHA4

SYMBOL	NAME	SYMBOL	NAME	SYMBOL	NAME
T01	Temperature Sensor	IPM	Power Module	LED1,LED2	LED
MC	Motor for Compressor	PTC	Converter	FI-4	<Operation Inspection Indicators>
MF1	Fan Motor	CB-I-C-BO	Main Smoothing Capacitor	SWP	Switch-Pump Down
Z1S4	High Pressure Safety Switch	LULO	Noise Filter Circuit Board	EH1	Connector-Emergency Operation
EH	High Pressure Safety Switch	NIN4	Connection Terminal-N-Phase	EN1	Connector-Connection for Option
TH3, TH33	Thermistor-Outdoor Pipe	E1,E2,E3	Connection Terminal-E-Phase	SS	Connector-Connection for Option
TH4	Thermistor-Outdoor Pipe	SZC	SBC Relay	CNM	Connector-A-Control Service Inspection Kit
TAB	Thermistor-Indoor Pipe	C-9	Control Circuit Board	CNMHT	Connector <Connected to Optional M-NET Adapter Board>
TAF	Thermistor-Indoor Pipe	SW1	Switch-Forced Defrost, Defect History Record Reset, Refrigerant Address	CNMNT	Connector <Connected to Optional M-NET Adapter Board>
TB8	Thermistor-Heat Sink	SW4	Switch-Test Operation	CHDM	Connector <Connected to Optional M-NET Adapter Board>
TR32	Thermistor-Heat Sink	SW5	Switch-Function Switch	CNM	Connector < Connected for Option (Contact Input)>
LEV-A,LEV-B	Level Sensor	SW6	Switch-Mode Select	X51,X52	Relay
RA1	Reactor	SW7	Switch-Function Setup		
C1,C2	Power Circuit Board	SW8	Switch-Function Setup		
P.B	Power Circuit Board	SWS	Switch		
TABR	Connection Terminal-L-Phase				
TAR1WV	Connection Terminal-U-V-W-Phase				

When M-NET adapter is connected

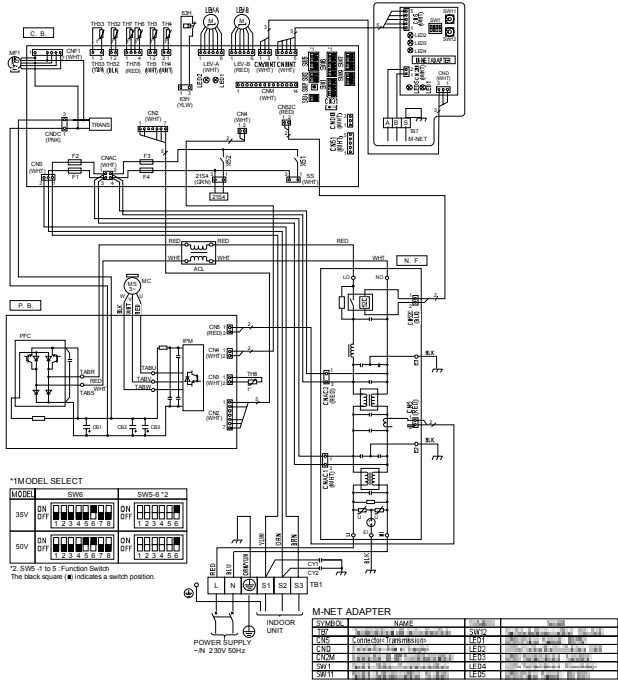

*1 MODEL SELECT

MODEL	SWS	SWS-S*2
35V	ON OFF 1 2 3 4 5 6 7 8	ON OFF 1 2 3 4 5 6
50V	ON OFF 1 2 3 4 5 6 7 8	ON OFF 1 2 3 4 5 6

*2. SW5-1 to 5: Function Switch
The black square (■) indicates a switch position.

M-NET ADAPTER

SYMBOL	NAME	SW2
TR	Relay	LED1
EN5	Connector-Transmission	LED2
CND	Connector-Data Transfer	LED3
CNM	Connector-Data Transfer	LED4
SW1	Switch	LED5
SW11	Switch	LED5

PUHZ-RP60VHA4 PUHZ-RP71VHA4

SYMBOL	NAME	SYMBOL	NAME	SYMBOL	NAME
TB1	Terminal Block	PF	Converter	FF-4	Fuse (16.3A/250V)
MC	Main Circuit Capacitor	CF-C, CB	Main Smoothing Capacitor	SWP	Switch-Phase Down
MF	Fuse (Main)	N.F.	Noise Filter Circuit Board	LENS	LED-Emergency Operation
Z1S4	Terminal-Phase	L1, L2, L3	Connection Terminal-L-Phase	CNE1	Connector-Connection for Option
E3H	High Temperature Switch	N1, N2	Connection Terminal-N-Phase	S.S	Connector-Connection for Option
TR3, TR32	Thermistor-Outdoor Phase	SLC, L3	Connection Terminal-Ground	CNMT	Connector-A Control Service Inspection Kit
TR4	Thermistor-Indoor Phase	S2C	S2C-Relay	CNMT	Connector
TR6	Thermistor-Sub	C	Controller Circuit Board	CNMT	Connector
TR7	Thermistor-Outdoor	SW1	Switch-Forced Defrost, Defect History Record Reset, Outgoing Address	CNMT	Connector
TR8	Thermistor-Indoor	SW2	Switch-Function Setup	CNMT	Connector
TR32	Thermistor-Sub	SW4	Switch-Test Operation	CNMT	Connector
LEVA, LEVB	LED	SW5	Switch-Function Setup	ZS1, ZS2	Relay
ACL	Reactor	SW6	Switch-Model Select		
CV1, CV2	Capacitor	SW7	Switch-Function Setup		
P.B.	Phase Circuit Board	SW8	Switch-Function Setup		
TABR, S	Connection Terminal-N-Phase	SW9	Switch		
TABU, W, V	Connection Terminal-U, V, W-Phase	LED, LED2	LED		
PM	Power Module				

When M-NET adapter is connected

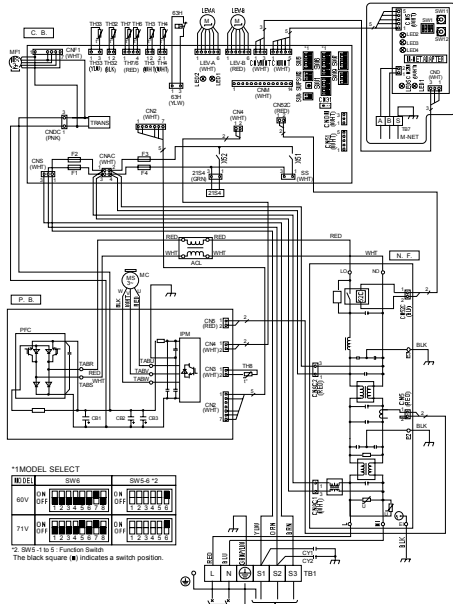

**MODEL SELECT

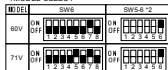

POWER SUPPLY -N 230V 50Hz

SYMBOL	NAME	SYMBOL	NAME
TB7	Terminal Block-M-Net connector	SW12	Switch-Address setting -10digit
CH5	Connector-Transmission	LED1	LED-Power Supply (DC5V)
CND	Connector-Power Supply	LED2	LED-Connection to Outdoor Unit
CNM	Connector-M-Net communication	LED3	LED-Transmission Standby
SW1	Switch-Status of communication	LED4	LED-Transmission Recovery
SW11	Switch-Address setting -16digit	LED6	LED-Power Supply (DC12V)

PUHZ-RP100VKA PUHZ-RP125VKA PUHZ-RP140VKA

SYMBOL	NAME	SYMBOL	NAME	SYMBOL	NAME
TB1	Terminal Block	L1	Connection Terminal-L-Phase	SWF	Switch-Pump Down
UB	Motor for Compressor	N1	Connection Terminal-N-Phase	CB1	Connector-Emergency Operation
MF1, MF2	Fan Motor	P2	Connection Terminal	L1 to 1	Connector-Connection for Option
Z1S4	Pressure Sensor (High Pressure)	N2	Connection Terminal	CS	Connector-Connection for Option
R3H	High Pressure Switch	UD(L1, D1, L2)	Connection Terminal-Receiver	CRM	Connector-Connection Service Inspection Kit
TR3, TR33	Thermistor-Outdoor Pipe	UGA1	Power Module	CNM1T	Connector
TR4	Thermistor-Indoor Pipe	LE1,2, E3, E4	Connection Terminal-Ground	CRVMT1	Connector
TR5	Thermistor-Sub	CB	Controller Circuit Board	CRDM	Connector
TR7	Thermistor-Outdoor	SW1	Switch-Forced Defrost, Defrost History Record Reset, Refrigerant Address	LED1, LED2	LED-Operation Inspection Indicator
TR8	Thermistor-Sub	SW2	Switch-Test Operation	FT-F4	Fuse< TB, 9AL250V>
CR1, CR1R, CR1S	Compressor	SW3	Switch-Function Setup	X81, X82	Relay
DC1	Reactor	SW4	Switch-Function Setup		
LCB	Main Smoothing Capacitor	SW5	Switch-Function Setup		
CVT, CVZ	Capacitor	SW6	Switch-Function Setup		
FB	Power Circuit Board	SW9	Switch-Function Setup		
LUNW	Connection Terminal-LUNW-Phase	SW2	Switch		

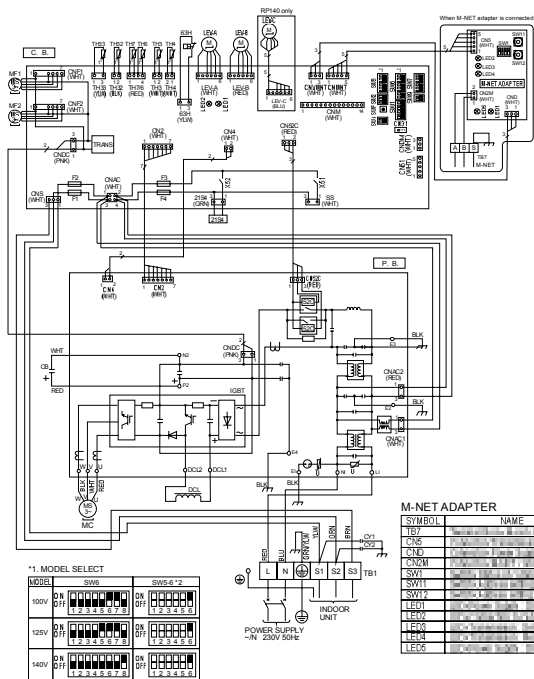

*1. MODEL SELECT

MODEL	SW6	SW5-6*2
100V	ON OFF 1 2 3 4 5 6 7 8	ON OFF 1 2 3 4 5 6
125V	ON OFF 1 2 3 4 5 6 7 8	ON OFF 1 2 3 4 5 6
140V	ON OFF 1 2 3 4 5 6 7 8	ON OFF 1 2 3 4 5 6

*2. SW5-1 to 5: Function Switch
The black square (■) indicates a switch position.

M-NET ADAPTER

SYMBOL	NAME
TB7	Terminal Block
CNS	Connector-Connection for Option
CND	Connector-Connection for Option
CNM	Connector-Connection for Option
CNM1T	Connector
SW1	Switch-Forced Defrost, Defrost History Record Reset, Refrigerant Address
SW12	Switch-Function Setup
LED1	LED-Operation Inspection Indicator
LED2	LED-Operation Inspection Indicator
LED3	LED-Operation Inspection Indicator
LED4	LED-Operation Inspection Indicator
LED5	LED-Operation Inspection Indicator

PUHZ-RP100YKA PUHZ-RP125YKA PUHZ-RP140YKA

SYMBOL	NAME	SYMBOL	NAME	SYMBOL	NAME
TR1	Terminal Block (Indoor Unit)	TR P2	Connection Terminal	SW5	Switch-Function Switch
TR2	Terminal Block (Outdoor Unit)	TR L1	Connection Terminal	SW6	Switch-Block Switch
MP	Motor for compressor	TR H1	Connection Terminal	SW7	Switch-Function Switch
MF1, MF2	Fan Motor	XS2A	SPC Relay	SW9	Switch-Function Switch
PLS4	Pressure Switch	N.F.	Flow Filter Circuit Board	SW9	Switch
TRH	TRIP Pressure Switch	L1(L1/L2/L3)	Connection Terminal (L1/L2/L3 Power Supply)	SWP	Switch-Function Switch
TRH3, TRH3<	Thermistor (Outdoor Pipe)	L1(L1/L2/L3)	Connection Terminal (L1/L2/L3 Power Supply)	EHST	Switch-Function Switch
TR4	Thermistor (Outdoor Pipe)	CON1, TR3	Connection Terminal (Ground)	LED1, LED2	LED-Operation Inspection Indicators
TR5	Thermistor (Outdoor Pipe)	CON2, A	Connection Terminal (Ground)	F.F.F.4	Function Switch
TR7	Thermistor (Outdoor Pipe)	CON2, A	Connection Terminal (Ground)	CNM	Connector->Control Service Inspection Kit
TR32	Thermistor (Steel)	L1(2,6)	Connection Terminal-1.1-Power Supply	CNMNT	Connector
LEA1(R)LEP1	Electronic Expansion Valve	L1(2,6)	Connection Terminal-1.2-Power Supply	CNMNT	Connector
ACT1,ACT2,ACT3	Relay	L1(2,6)	Connection Terminal-1.3-Power Supply	CNMNT	Connector
LEB1,LEB2	Main Smoothing Capacitor	N IN	Connection Terminal	CNMNT	Connector
CK	Capacitor	CK, OJ	Connection Terminal	CNMNT	Connector
RS	High Current Protect Resistor	C.B	Controller Circuit Board	CNMNT	Connector
P.C.B	Power Circuit Board	SW1	Switch-Forward Defrost, Defrost History Record Reset, Refrigerant Address	CNMNT	Connector
TR LUVW	Connection Terminal (L1/L2/L3 Power Supply)	SW4	Switch-Test Operation	XS1, XS2	Relay
TR L1/L2/L3	Connection Terminal (L1/L2/L3 Power Supply)				

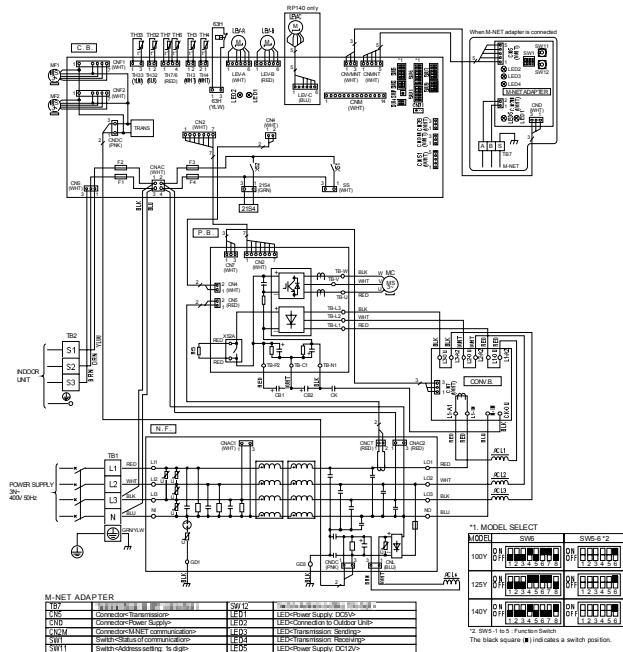

5-1. INDOOR UNIT

PLA-RP-BA/BA2/BA3

PEAD-RP-JA(L)

PCA-RP-KA

PCA-RP-HA

PSA-RP-GA

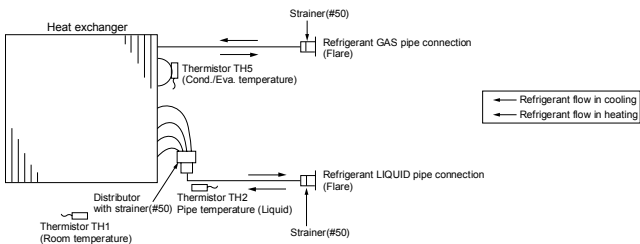

PKA-RP-HAL

PKA-RP-KAL

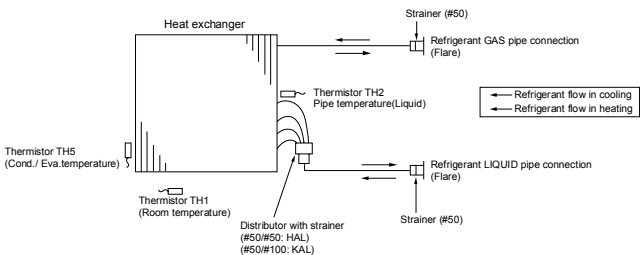

PEA-RP200, 250GA

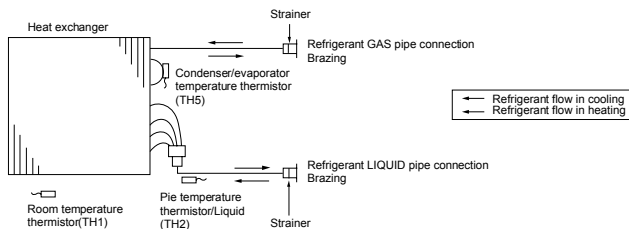

PEA-RP400GA PEA-RP500GA

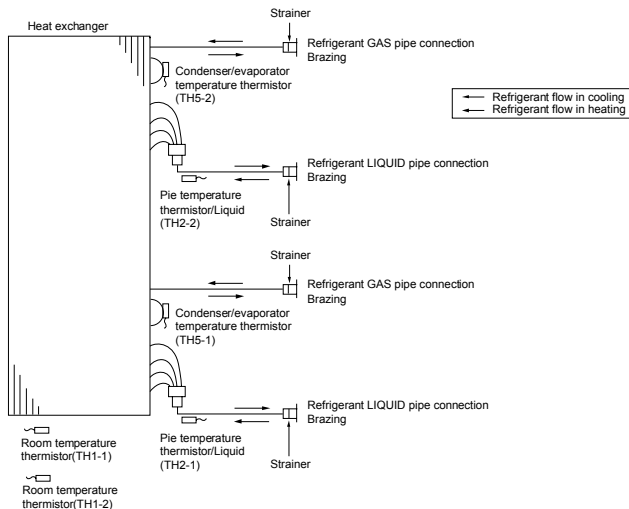

5-2. OUTDOOR UNIT
PUHZ-RP35VHA4
PUHZ-RP50VHA4

unit: mm(inch)

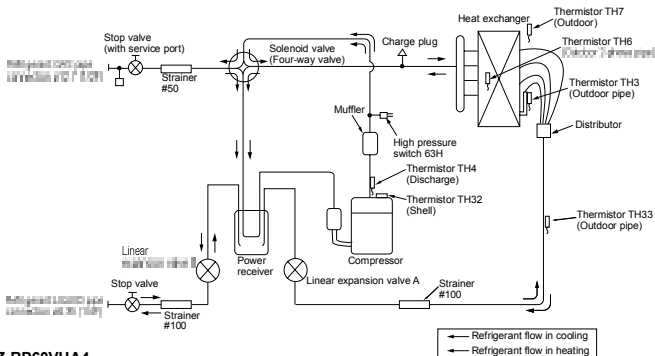

PUHZ-RP60VHA4
PUHZ-RP71VHA4

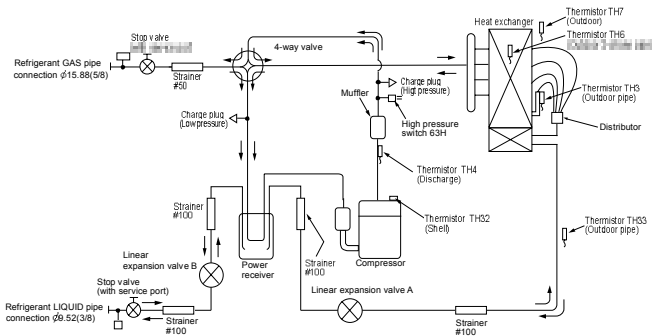

unit: mm(inch)

PUHZ-RP100VKA
PUHZ-RP100YKA

PUHZ-RP125VKA
PUHZ-RP125YKA

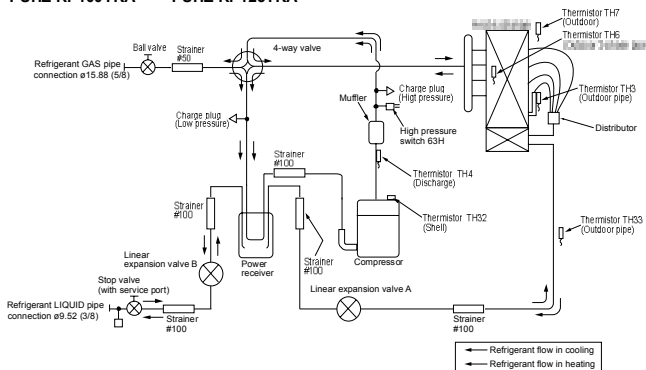

PUHZ-RP140VKA

PUHZ-RP140YKA

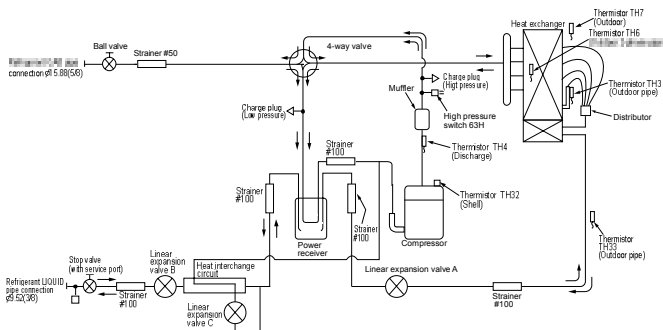

PUHZ-RP200YKA

unit: mm(inch)

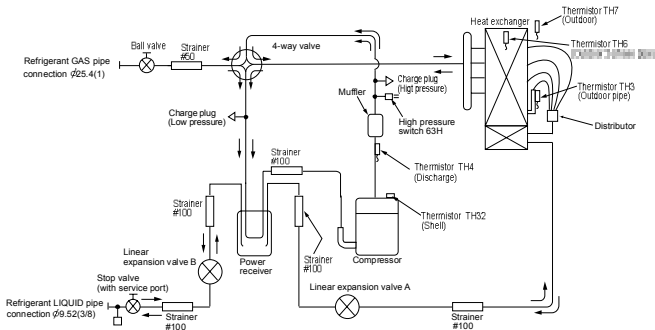

PUHZ-RP250YKA

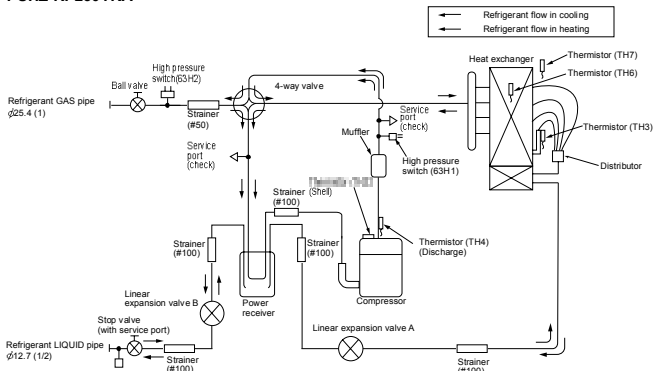

8-1. PUHZ-RP-VHA4 PUHZ-RP-VKA PUHZ-RP100-140YKA

8-1-1. PIPE LENGTH

(1) 1:1 SYSTEM

Pipe length

<Table 1> Maximum pipe length

Liquid pipe (mm)	ø6.35			ø9.52			ø12.7			
	OD	Thickness	10.8	ø9.52	ø12.7	ø15.88	ø19.05	ø15.88	ø19.05	
Gas pipe (mm)	OD	Thickness	ø9.52 10.8	ø12.7 10.8	ø15.88 11.0	ø12.7 10.8	ø15.88 11.0	ø19.05 11.0	ø15.88 11.0	ø19.05 11.0
	RP35-50	□ 30m×1 (30m)	Standard size 50m (30m)	○×2 30m (30m)	△ 30m (20m)	△×2 30m (20m)	/	/	/	/
RP60-71	/	□ 10m (10m)	○ 10m (10m)	□ 30m (30m)	Standard size 50m (30m)	/	/	△ 30m (20m)	/	/
RP100-140	/	/	/	/	Standard size 50m×3 (30m)	○ 50m (30m)	/	△ 50m (20m)	/	△ 50m (20m)

*Maximum pipe length

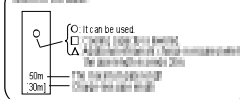

※ RP100: maximum pipe length is 100m.

※ □ Change the DN15.1 and the outdoor condenser actual selection OFF to ON.

※ △ The maximum length is 75m in case of new pipes.

(2) TWIN AND TRIPLE SYSTEM

(a) TWIN SYSTEM

<Table 2> Maximum pipe length

Main pipe (mm) (A)	Liquid pipe Gas pipe	RP71 (RP35×2)		RP100 (RP60×2)		RP125 (RP60×2) • RP140 (RP71×2)			
		ø6.35 ø12.7	ø9.52 ø15.88	ø9.52 ø15.88	ø9.52 ø19.05	ø12.7 ø19.05	ø9.52 ø15.88	ø9.52 ø19.05	ø12.7 ø19.05
Branch pipe (mm) (B, C)	Liquid pipe	ø6.35	Standard size 50m (30m)	Standard size 50m× (30m)	○ 50m (30m)	△ 50m (20m)	/	/	/
	Gas pipe	ø12.7	/	/	○ 50m (30m)	△ 50m (20m)	/	/	/
	Liquid pipe	ø9.52	/	○ 50m (30m)	○ 50m (30m)	○ 50m (20m)	Standard size 50m× (30m)	○ 50m (30m)	△ 50m (20m)
	Gas pipe	ø15.88	/	/	/	/	/	○ 50m (30m)	△ 50m (20m)
	Liquid pipe	ø12.7	/	/	/	/	/	/	/
Gas pipe	ø19.05	/	/	/	/	/	/	/	

* The maximum length is 75m in case of new pipes.

(b) TRIPLE SYSTEM

<Table 3> Maximum pipe length

Main pipe (mm) (A)	Liquid pipe Gas pipe	RP140 (RP50×3)			
		ø9.52 ø15.88	ø9.52 ø19.05	ø12.7 ø19.05	
Branch pipe (mm) (B, C, D)	Liquid pipe	ø6.35	Standard size 50m× (30m)	○ 50m (30m)	△ 50m (20m)
	Gas pipe	ø12.7	/	/	/
	Liquid pipe	ø9.52	/	○ 50m (30m)	△ 50m (20m)
	Gas pipe	ø15.88	/	/	/
	Liquid pipe	ø12.7	/	/	/
Gas pipe	ø19.05	/	/	/	

* The maximum length is 75m in case of new pipes.

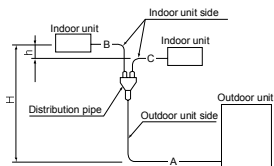

<TWIN SYSTEM>

Total length A + B + C

RP71 : 50 m

RP100-140: 75 m

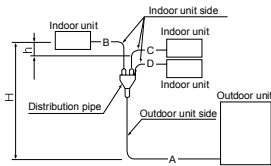

<TRIPLE SYSTEM>

Total length A + B + C + D

RP140: 75 m

8-1-2. ADJUSTING THE AMOUNT OF REFRIGERANT

- Check additional refrigerant charging amount referring to table 5, 6 when liquid pipe is 1 size larger than standard diameter.

<Table 5> Required additional charge when the pipe size is 1 size larger than the standard diameter (1:1 SYSTEM)

Outdoor unit	Liquid pipe O.D.	Refrigerant amount to be added
PUHZ-RP35,50	φ9.52	60 g per 1 m
PUHZ-RP60,71	φ12.7	100 g per 1 m
PUHZ-RP100~140	φ12.7	100 g per 1 m

<Table 6> Required additional charge when the pipe size is 1 size larger than the standard diameter (TWIN/TRIPLE SYSTEM)

Outdoor unit	When the extension pipe length (main piping + branch piping) exceeds 20 m
PUHZ-RP71~140	Additional refrigerant amount $\Delta W(g) = (100 \times L1) + (60 \times L2) + (30 \times L3) - 2000$

If the calculation produces a negative number ($\Delta W \leq 0$), additional charging is not necessary.

L1: φ12.7 liquid pipe length (m)

L2: φ9.52 liquid pipe length (m)

L3: φ6.35 liquid pipe length (m)

<Table 7> Additional refrigerant charging amount for pipe of standard diameter

Type	Outdoor unit	Permitted pipe length	Amount of unit filling refrigerant (kg)	Additional refrigerant charging amount for pipe length exceeding 30 m (kg)				
				31 – 40m	41 – 50m	51 – 60m	61 – 70m	71 – 75m
1:1 system	PUHZ-RP35,50	50m or less	2.5kg	0.2kg	0.4kg			
	PUHZ-RP71		3.5kg	0.6kg	1.2kg			
	PUHZ-RP100~140	75m or less	5.0kg	0.6kg	1.2kg	1.8kg	2.4kg	

Type	Outdoor unit	Permitted pipe length	Amount of unit filling refrigerant (kg)	Additional refrigerant charging amount for pipe length exceeding 30 m (kg)				
				31 – 40m	41 – 50m	51 – 60m	61 – 70m	71 – 75m
Twin Triple system	PUHZ-RP71	50m or less	3.5kg	0.6kg	1.2kg			
	PUHZ-RP100~140	75m or less	5.0kg	0.6kg	1.2kg	1.8kg	2.4kg	

8-1-3. CAPACITY CORRECTION CURVES

Cooling and heating capacity is lowered according to pipe length. Capacity can be obtained by referring to the capacity curves below. When the diameter of gas pipe is 1 size smaller than standard diameter, cooling capacity is lowered comparing to the standard diameter. The lowered capacity can be obtained by referring to capacity curves for gas pipe which is 1 size smaller than standard size.

Corrected pipe length (m) = actual pipe length (m) + number of bends \times 0.3 (m)

[Sample calculation]

Indoor unit RP60 \times 2 units (Twin system)

Outdoor unit RP125 \times 1

■ Condition Using existing pipes.

- Outdoor unit side
Liquid pipe ϕ 12.7 / Gas pipe ϕ 19.05
pipe length (A) 20m

- Indoor unit side
Liquid pipe ϕ 9.52 / Gas pipe ϕ 15.88
pipe length (B) 20m + (C) 15m

- 1) Farthest piping length 20m + 15m = 35m
Number of bends : 10
- 2) Corrected piping length 35m + 0.3 \times 10 = 38m
- 3) Capacity correction Outdoor unit side's gas pipe ϕ 19.05
Standard ϕ 15.88 \rightarrow 1 size up
Refer to ① Capacity curves <Standard size>
- 4) Capacity
Cooling capacity = Standard cooling capacity \times 0.89
Heating capacity = Standard heating capacity \times 0.98

① Capacity curves for PUHZ-RP · HA2 model <Standard size>

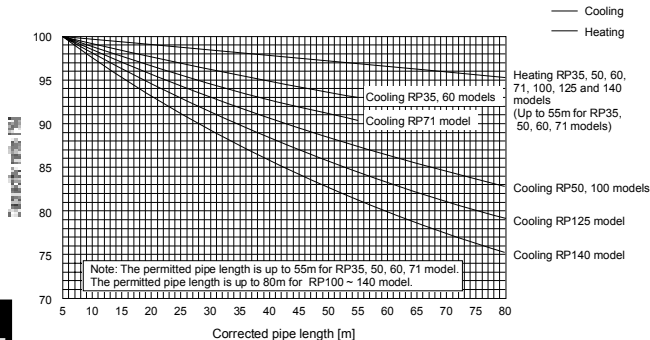

② Capacity curve for PUAZ-RP35, 50 models
 <When gas pipe is 1 size smaller than standard size>

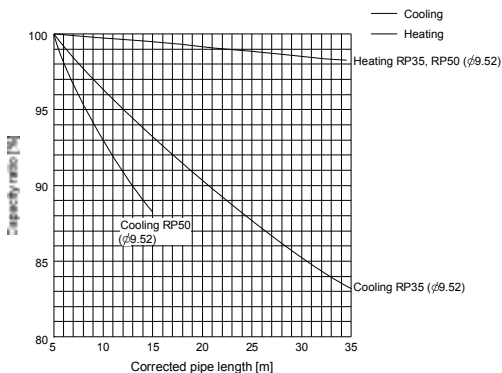

③ Capacity curve for PUAZ-RP60, 71 models
 <When gas pipe is 1 size smaller than standard size>

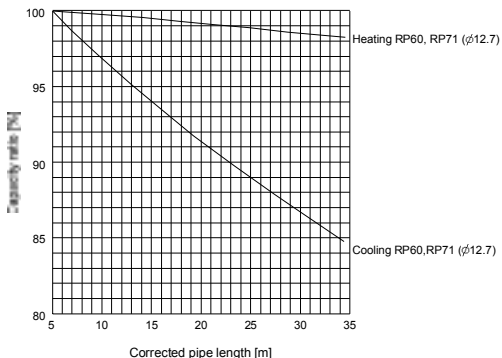

④ When gas pipe is one size larger than standard size for PUAZ-RP100, 125 and 140.

① Capacity can be obtained by referring to capacity curves of standard size.

8-2. PUHZ-RP200-250YKA

8-2-1. 1:1 SYSTEM

(1) Pipe length

<Table 1> Maximum pipe length (RP200-RP250)

Liquid pipe (mm)	O.D.	φ9.52				φ12.7				φ15.88			
	Thickness	t0.8				t0.8				t1.0			
Gas pipe (mm)	O.D.	φ19.05	φ22.2	φ25.4	φ28.58	φ19.05	φ22.2	φ25.4	φ28.58	φ22.2	φ25.4	φ28.58	φ31.75
	Thickness	t1.0	t1.0	t1.0	t1.0	t1.0	t1.0	t1.0	t1.0	t1.0	t1.0	t1.0	t1.1
RP200		□ 20m [20m]	□ 50m [30m]	Standard size 120m [30m]	○ 120m [30m]	□ 20m [20m]	□ 50m [30m]	○ 120m [30m]	○ 120m [30m]	△□ 50m [20m]	△ 50m [20m]	△ 50m [20m]	△ 50m [20m]
RP250		□ 20m [20m]	□ 50m [30m]	○ 120m [30m]	○ 120m [30m]	□ 20m [20m]	□ 50m [30m]	Standard size 120m [30m]	○ 120m [30m]	△□ 50m [20m]	△ 50m [20m]	△ 50m [20m]	△ 50m [20m]

Note : Be sure to use hard (tempered) one for pipe over φ22.2(RP200)/φ19.05(RP250).

<Marks in the table above>

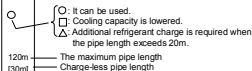

(2) Adjusting the amount of refrigerant

Check additional refrigerant charging amount referring to table 7 when the liquid pipe diameter is 1 size larger than the standard size, and table 2 when the pipe of the standard diameter is used.

<Table 2>

Outdoor unit	permitted pipe length	Initial charge (kg)	Amount of additional refrigerant charge (kg)					
			30 m and less	31-40 m and less	41-50 m and less	51-60 m and less	61-70 m and less	71-120 m and less
RP200	120m or less	7.1	No additional charge necessary	0.9 kg	1.8 kg	2.7 kg	3.6 kg	The additional charge amount is obtained by the following formula.
RP250		7.7	1.2 kg	2.4 kg	3.6 kg	4.8 kg		

When length exceeds 70 m

When the total length of the piping exceeds 70 m, calculate the amount of additional charge based on the following requirements.
Note: If the calculation produces a negative number (i.e. a "minus" charge), if of calculation results in an amount that is less than the "Additional charge amount for 70 m", perform the additional charge using the amount shown in "Additional charge amount for 70 m".

Amount of additional charge (kg)	=	Main piping: Liquid line size φ12.7 overall length × 0.11 (m) × 0.11 (kg/m)	+	Main piping: Liquid line size φ9.52 overall length × 0.09 (Gas line: φ25.4) (m) × 0.09 (kg/m)	+	Branch piping: Liquid line size φ9.52 overall length × 0.06 (Gas line: φ15.88) (m) × 0.06 (kg/m)	+	Branch piping: Liquid line size φ6.35 overall length × 0.02 (m) × 0.02 (kg/m)	-	3.6 (kg)
Additional charge amount for 70 meters		RP200 3.6 kg		RP250 4.8 kg						

*If the wiring connecting the indoor and outdoor units is longer than 80m, use separate indoor /outdoor unit power supplies.

(3) Capacity correction

Cooling and heating capacity is lowered according to the piping length. Capacity can be obtained by referring to the following capacity curves.

When the diameter of the gas pipe is smaller than the standard size, cooling capacity is lowered comparing to the operation using the standard diameter pipe.

The lowered capacity can be obtained by referring to the capacity curves for gas pipe which is 1 or 2 size smaller than standard size.

Corrected pipe length (m) = actual pipe length (m) + number of bends × 0.3 (m)

1. Capacity curves 1 <Standard size>

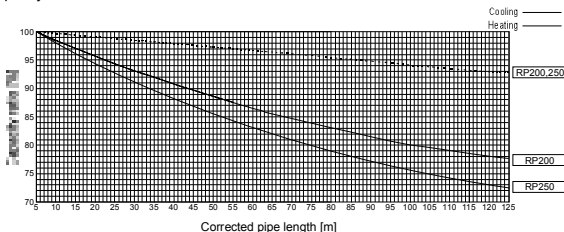

2. Capacity curves 2 <When the gas pipe's diameter is 1-size-smaller than the standard size>

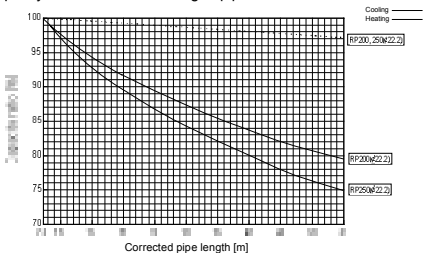

3. Capacity curves 3 <When the gas pipe's diameter is 2-size-smaller than the standard size>

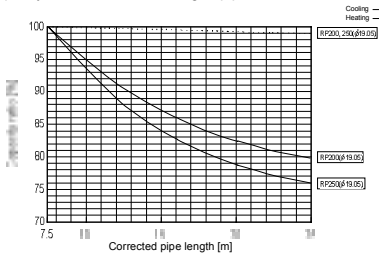

※ RP250
Use 1/2H or H pipes if the diameter is 19.05.

2. TWIN, TRIPLE AND QUADRUPLE SYSTEM

(1) Twin

Maximum pipe length (Main pipe [A] + Branch pipe diameter [B and C])

Main pipe (mm) [A]	Liquid pipe Gas pipe	RP200 twin (RP100X2)										RP250 twin (RP125X2)																																																																																																																																																																																																																																																																																																																																																																																																																																																																																																																																																																																																																																																																																																																																																																																																																																																																																																																																																																																																				
		φ9.52					φ12.7					φ15.88					φ9.52					φ12.7					φ15.88																																																																																																																																																																																																																																																																																																																																																																																																																																																																																																																																																																																																																																																																																																																																																																																																																																																																																																																																																																																					
Branch pipe (mm) [B, C]	Liquid pipe	φ9.52	φ15.88	φ20	φ25.4	φ30	φ38.1	φ45.4	φ50.8	φ57.1	φ63.5	φ76.2	φ91.4	φ101.6	φ114.3	φ127	φ152.4	φ177.8	φ203.2	φ228.6	φ254	φ304.8	φ355.2	φ405.6	φ456	φ506.4	φ556.8	φ607.2	φ657.6	φ708	φ758.4	φ808.8	φ859.2	φ909.6	φ960	φ1010.4	φ1060.8	φ1111.2	φ1161.6	φ1212	φ1262.4	φ1312.8	φ1363.2	φ1413.6	φ1464	φ1514.4	φ1564.8	φ1615.2	φ1665.6	φ1716	φ1766.4	φ1816.8	φ1867.2	φ1917.6	φ1968	φ2018.4	φ2068.8	φ2119.2	φ2169.6	φ2220	φ2270.4	φ2320.8	φ2371.2	φ2421.6	φ2472	φ2522.4	φ2572.8	φ2623.2	φ2673.6	φ2724	φ2774.4	φ2824.8	φ2875.2	φ2925.6	φ2976	φ3026.4	φ3076.8	φ3127.2	φ3177.6	φ3228	φ3278.4	φ3328.8	φ3379.2	φ3429.6	φ348	φ3538.4	φ3588.8	φ3639.2	φ3689.6	φ374	φ3793.6	φ3843.2	φ3892.8	φ3942.4	φ3992	φ4041.6	φ4091.2	φ4140.8	φ4190.4	φ424	φ4293.6	φ4343.2	φ4392.8	φ4442.4	φ4492	φ4541.6	φ4591.2	φ4640.8	φ4690.4	φ474	φ4793.6	φ4843.2	φ4892.8	φ4942.4	φ4992	φ5041.6	φ5091.2	φ5140.8	φ5190.4	φ524	φ5293.6	φ5343.2	φ5392.8	φ5442.4	φ5492	φ5541.6	φ5591.2	φ5640.8	φ5690.4	φ574	φ5793.6	φ5843.2	φ5892.8	φ5942.4	φ5992	φ6041.6	φ6091.2	φ6140.8	φ6190.4	φ624	φ6293.6	φ6343.2	φ6392.8	φ6442.4	φ6492	φ6541.6	φ6591.2	φ6640.8	φ6690.4	φ674	φ6793.6	φ6843.2	φ6892.8	φ6942.4	φ6992	φ7041.6	φ7091.2	φ7140.8	φ7190.4	φ724	φ7293.6	φ7343.2	φ7392.8	φ7442.4	φ7492	φ7541.6	φ7591.2	φ7640.8	φ7690.4	φ774	φ7793.6	φ7843.2	φ7892.8	φ7942.4	φ7992	φ8041.6	φ8091.2	φ8140.8	φ8190.4	φ824	φ8293.6	φ8343.2	φ8392.8	φ8442.4	φ8492	φ8541.6	φ8591.2	φ8640.8	φ8690.4	φ874	φ8793.6	φ8843.2	φ8892.8	φ8942.4	φ8992	φ9041.6	φ9091.2	φ9140.8	φ9190.4	φ924	φ9293.6	φ9343.2	φ9392.8	φ9442.4	φ9492	φ9541.6	φ9591.2	φ9640.8	φ9690.4	φ974	φ9793.6	φ9843.2	φ9892.8	φ9942.4	φ9992	φ10041.6	φ10091.2	φ10140.8	φ10190.4	φ1024	φ10293.6	φ10343.2	φ10392.8	φ10442.4	φ10492	φ10541.6	φ10591.2	φ10640.8	φ10690.4	φ1074	φ10793.6	φ10843.2	φ10892.8	φ10942.4	φ10992	φ11041.6	φ11091.2	φ11140.8	φ11190.4	φ1124	φ11293.6	φ11343.2	φ11392.8	φ11442.4	φ11492	φ11541.6	φ11591.2	φ11640.8	φ11690.4	φ1174	φ11793.6	φ11843.2	φ11892.8	φ11942.4	φ11992	φ12041.6	φ12091.2	φ12140.8	φ12190.4	φ1224	φ12293.6	φ12343.2	φ12392.8	φ12442.4	φ12492	φ12541.6	φ12591.2	φ12640.8	φ12690.4	φ1274	φ12793.6	φ12843.2	φ12892.8	φ12942.4	φ12992	φ13041.6	φ13091.2	φ13140.8	φ13190.4	φ1324	φ13293.6	φ13343.2	φ13392.8	φ13442.4	φ13492	φ13541.6	φ13591.2	φ13640.8	φ13690.4	φ1374	φ13793.6	φ13843.2	φ13892.8	φ13942.4	φ13992	φ14041.6	φ14091.2	φ14140.8	φ14190.4	φ1424	φ14293.6	φ14343.2	φ14392.8	φ14442.4	φ14492	φ14541.6	φ14591.2	φ14640.8	φ14690.4	φ1474	φ14793.6	φ14843.2	φ14892.8	φ14942.4	φ14992	φ15041.6	φ15091.2	φ15140.8	φ15190.4	φ1524	φ15293.6	φ15343.2	φ15392.8	φ15442.4	φ15492	φ15541.6	φ15591.2	φ15640.8	φ15690.4	φ1574	φ15793.6	φ15843.2	φ15892.8	φ15942.4	φ15992	φ16041.6	φ16091.2	φ16140.8	φ16190.4	φ1624	φ16293.6	φ16343.2	φ16392.8	φ16442.4	φ16492	φ16541.6	φ16591.2	φ16640.8	φ16690.4	φ1674	φ16793.6	φ16843.2	φ16892.8	φ16942.4	φ16992	φ17041.6	φ17091.2	φ17140.8	φ17190.4	φ1724	φ17293.6	φ17343.2	φ17392.8	φ17442.4	φ17492	φ17541.6	φ17591.2	φ17640.8	φ17690.4	φ1774	φ17793.6	φ17843.2	φ17892.8	φ17942.4	φ17992	φ18041.6	φ18091.2	φ18140.8	φ18190.4	φ1824	φ18293.6	φ18343.2	φ18392.8	φ18442.4	φ18492	φ18541.6	φ18591.2	φ18640.8	φ18690.4	φ1874	φ18793.6	φ18843.2	φ18892.8	φ18942.4	φ18992	φ19041.6	φ19091.2	φ19140.8	φ19190.4	φ1924	φ19293.6	φ19343.2	φ19392.8	φ19442.4	φ19492	φ19541.6	φ19591.2	φ19640.8	φ19690.4	φ1974	φ19793.6	φ19843.2	φ19892.8	φ19942.4	φ19992	φ20041.6	φ20091.2	φ20140.8	φ20190.4	φ2024	φ20293.6	φ20343.2	φ20392.8	φ20442.4	φ20492	φ20541.6	φ20591.2	φ20640.8	φ20690.4	φ2074	φ20793.6	φ20843.2	φ20892.8	φ20942.4	φ20992	φ21041.6	φ21091.2	φ21140.8	φ21190.4	φ2124	φ21293.6	φ21343.2	φ21392.8	φ21442.4	φ21492	φ21541.6	φ21591.2	φ21640.8	φ21690.4	φ2174	φ21793.6	φ21843.2	φ21892.8	φ21942.4	φ21992	φ22041.6	φ22091.2	φ22140.8	φ22190.4	φ2224	φ22293.6	φ22343.2	φ22392.8	φ22442.4	φ22492	φ22541.6	φ22591.2	φ22640.8	φ22690.4	φ2274	φ22793.6	φ22843.2	φ22892.8	φ22942.4	φ22992	φ23041.6	φ23091.2	φ23140.8	φ23190.4	φ2324	φ23293.6	φ23343.2	φ23392.8	φ23442.4	φ23492	φ23541.6	φ23591.2	φ23640.8	φ23690.4	φ2374	φ23793.6	φ23843.2	φ23892.8	φ23942.4	φ23992	φ24041.6	φ24091.2	φ24140.8	φ24190.4	φ2424	φ24293.6	φ24343.2	φ24392.8	φ24442.4	φ24492	φ24541.6	φ24591.2	φ24640.8	φ24690.4	φ2474	φ24793.6	φ24843.2	φ24892.8	φ24942.4	φ24992	φ25041.6	φ25091.2	φ25140.8	φ25190.4	φ2524	φ25293.6	φ25343.2	φ25392.8	φ25442.4	φ25492	φ25541.6	φ25591.2	φ25640.8	φ25690.4	φ2574	φ25793.6	φ25843.2	φ25892.8	φ25942.4	φ25992	φ26041.6	φ26091.2	φ26140.8	φ26190.4	φ2624	φ26293.6	φ26343.2	φ26392.8	φ26442.4	φ26492	φ26541.6	φ26591.2	φ26640.8	φ26690.4	φ2674	φ26793.6	φ26843.2	φ26892.8	φ26942.4	φ26992	φ27041.6	φ27091.2	φ27140.8	φ27190.4	φ2724	φ27293.6	φ27343.2	φ27392.8	φ27442.4	φ27492	φ27541.6	φ27591.2	φ27640.8	φ27690.4	φ2774	φ27793.6	φ27843.2	φ27892.8	φ27942.4	φ27992	φ28041.6	φ28091.2	φ28140.8	φ28190.4	φ2824	φ28293.6	φ28343.2	φ28392.8	φ28442.4	φ28492	φ28541.6	φ28591.2	φ28640.8	φ28690.4	φ2874	φ28793.6	φ28843.2	φ28892.8	φ28942.4	φ28992	φ29041.6	φ29091.2	φ29140.8	φ29190.4	φ2924	φ29293.6	φ29343.2	φ29392.8	φ29442.4	φ29492	φ29541.6	φ29591.2	φ29640.8	φ29690.4	φ2974	φ29793.6	φ29843.2	φ29892.8	φ29942.4	φ29992	φ30041.6	φ30091.2	φ30140.8	φ30190.4	φ3024	φ30293.6	φ30343.2	φ30392.8	φ30442.4	φ30492	φ30541.6	φ30591.2	φ30640.8	φ30690.4	φ3074	φ30793.6	φ30843.2	φ30892.8	φ30942.4	φ30992	φ31041.6	φ31091.2	φ31140.8	φ31190.4	φ3124	φ31293.6	φ31343.2	φ31392.8	φ31442.4	φ31492	φ31541.6	φ31591.2	φ31640.8	φ31690.4	φ3174	φ31793.6	φ31843.2	φ31892.8	φ31942.4	φ31992	φ32041.6	φ32091.2	φ32140.8	φ32190.4	φ3224	φ32293.6	φ32343.2	φ32392.8	φ32442.4	φ32492	φ32541.6	φ32591.2	φ32640.8	φ32690.4	φ3274	φ32793.6	φ32843.2	φ32892.8	φ32942.4	φ32992	φ33041.6	φ33091.2	φ33140.8	φ33190.4	φ3324	φ33293.6	φ33343.2	φ33392.8	φ33442.4	φ33492	φ33541.6	φ33591.2	φ33640.8	φ33690.4	φ3374	φ33793.6	φ33843.2	φ33892.8	φ33942.4	φ33992	φ34041.6	φ34091.2	φ34140.8	φ34190.4	φ3424	φ34293.6	φ34343.2	φ34392.8	φ34442.4	φ34492	φ34541.6	φ34591.2	φ34640.8	φ34690.4	φ3474	φ34793.6	φ34843.2	φ34892.8	φ34942.4	φ34992	φ35041.6	φ35091.2	φ35140.8	φ35190.4	φ3524	φ35293.6	φ35343.2	φ35392.8	φ35442.4	φ35492	φ35541.6	φ35591.2	φ35640.8	φ35690.4	φ3574	φ35793.6	φ35843.2	φ35892.8	φ35942.4	φ35992	φ36041.6	φ36091.2	φ36140.8	φ36190.4	φ3624	φ36293.6	φ36343.2	φ36392.8	φ36442.4	φ36492	φ36541.6	φ36591.2	φ36640.8	φ36690.4	φ3674	φ36793.6	φ36843.2	φ36892.8	φ36942.4	φ36992	φ37041.6	φ37091.2	φ37140.8	φ37190.4	φ3724	φ37293.6	φ37343.2	φ37392.8	φ37442.4	φ37492	φ37541.6	φ37591.2	φ37640.8	φ37690.4	φ3774	φ37793.6	φ37843.2	φ37892.8	φ37942.4	φ37992	φ38041.6	φ38091.2	φ38140.8	φ38190.4	φ3824	φ38293.6	φ38343.2	φ38392.8	φ38442.4	φ38492	φ38541.6	φ38591.2	φ38640.8	φ38690.4	φ3874	φ38793.6	φ38843.2	φ38892.8	φ38942.4	φ38992	φ39041.6	φ39091.2	φ39140.8	φ39190.4	φ3924	φ39293.6	φ39343.2	φ39392.8	φ39442.4	φ39492	φ39541.6	φ39591.2	φ39640.8	φ39690.4	φ3974	φ39793.6	φ39843.2	φ39892.8	φ39942.4	φ39992	φ40041.6	φ40091.2	φ40140.8	φ40190.4	φ4024	φ40293.6	φ40343.2	φ40392.8	φ40442.4	φ40492	φ40541.6	φ40591.2	φ40640.8	φ40690.4	φ4074	φ40793.6	φ40843.2	φ40892.8	φ40942.4	φ40992	φ41041.6	φ41091.2	φ41140.8	φ41190.4	φ4124	φ41293.6	φ41343.2	φ41392.8	φ41442.4	φ41492	φ41541.6	φ41591.2	φ41640.8	φ41690.4	φ4174	φ41793.6	φ41843.2	φ41892.8	φ41942.4	φ41992	φ42041.6	φ42091.2	φ42140.8	φ42190.4	φ4224	φ42293.6	φ42343.2	φ42392.8	φ42442.4	φ42492	φ42541.6	φ42591.2	φ42640.8	φ42690.4	φ4274	φ42793.6	φ42843.2	φ42892.8	φ42942.4	φ42992	φ43041.6	φ43091.2	φ43140.8	φ43190.4	φ4324	φ43293.6	φ43343.2	φ43392.8	φ43442.4	φ43492	φ43541.6	φ43591.2	φ43640.8	φ43690.4	φ4374	φ43793.6	φ43843.2	φ43892.8	φ43942.4	φ43992	φ44041.6	φ44091.2	φ44140.8	φ44190.4	φ4424	φ44293.6	φ44343.2	φ44392.8	φ44442.4	φ44492	φ44541.6	φ44591.2	φ44640.8	φ44690.4	φ4474	φ44793.6	φ44843.2	φ44892.8	φ44942.4	φ44992	φ45041.6	φ45091.2	φ45140.8	φ45190.4	φ4524	φ45293.6	φ45343.2	φ45392.8	φ45442.4	φ45492	φ45541.6	φ45591.2	φ45640.8	φ45690.4	φ4574	φ45793.6	φ45843.2	φ45892.8	φ45942.4	φ45992	φ46041.6	φ46091.2	φ46140.8	φ46190.4	φ4624	φ46293.6	φ46343.2	φ46392.8	φ46442.4	φ46492	φ46541.6	φ46591.2	φ46640.8	φ46690.4	φ4674	φ46793.6	φ46843.2	φ46892.8	φ46942.4	φ46992	φ47041.6	φ47091.2	φ47140.8	φ47190.4	φ4724	φ47293.6	φ47343.2	φ47392.8	φ47442.4	φ47492	φ47541.6	φ47591.2	φ47640.8	φ47690.4	φ4774	φ47793.6	φ47843.2	φ47892.8	φ47942.4	φ47992	φ48041.6

Pipe diameter and thickness

OD (mm)	φ6.35	φ9.52	φ12.7	φ15.88	φ19.05	φ22.2	φ25.4	φ28.58	φ31.75
Thickness (mm)	0.8	0.8	0.8	1.0	1.0	1.0	1.0	1.0	1.1

Be sure to use hard (tempered) one for pipe over φ19.05(RP250)/φ22.2(RP200).(Do not use soft (annealed) one.)

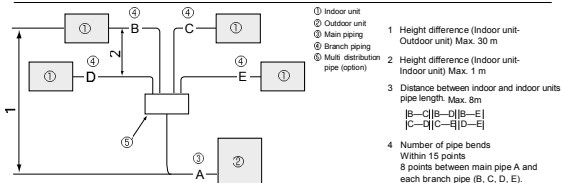

<Table 6> Lowered cooling capacity by the smaller gas pipe diameter

Pipe length	Cooling capacity ratio	
	gas pipe φ22.2	gas pipe φ19.05
5m and less	100%	100%
6-10m	100-95%	100-88%
11-20m	95-88%	88-77%
21-30m	88-83%	—
31-40m	83-79%	—
41-50m	79-75%	—

<Table 7> Additional refrigerant amount when the liquid pipe of the larger diameter is used. (Single / Simultaneous Twin / Simultaneous Triple / Simultaneous Quadruple)

Capacity	When the extension pipe length (main piping + branch piping) exceeds 20m
RP200, RP250	Additional refrigerant amount $\Delta W(g)=(180 \times L_1)+(120 \times L_2)+(90 \times L_3)+(30 \times L_4)-3000$

L₁: φ15.88 liquid pipe (m) L₂: φ12.7 liquid pipe (m)
 L₃: φ9.52 liquid pipe (m) L₄: φ6.35 liquid pipe (m)

If the calculation produces a negative number (i.e. a "minus" charge), additional charging is not necessary. ($\Delta W \leq 0$)

<Table 8>

Outdoor unit	Permissible total piping length A+B+C+D+E	A+B or A+C or A+D or A+E	Charge-less piping length A+B+C+D+E
RP200 PR250	120 m and less	100 m and less	30 m and less

<Table 9>

Outdoor unit	B-C or B-D or B-E or C-D or C-E or D-E	Number of pipe bends
RP200 RP250	8 m and less	Within 15

<Table 10>

Outdoor unit	Permitted pipe length	At time of shipping (kg)	A+B+C+D					Total DC in outdoor
			Amount of additional refrigerant charge (kg)					
			20m and less	21-25 m and less	26-30 m and less	31-35 m and less	36-40 m and less	
RP200	120m or less	7.1	No additional charge necessary	0.9 kg	1.8 kg	2.7 kg	3.6 kg	3.6 kg
RP250		7.7		1.2 kg	2.4 kg	3.6 kg	3.6 kg	

When length exceeds 70 m

When the total length of the piping exceeds 70m, calculate the amount of additional charge based on the following requirements.
 Note: If the calculation produces a negative number (i.e. a "minus" charge), or if calculation results in an amount that is less than the "Additional charge amount for 70 m," perform the additional charge using the amount shown in "Additional charge amount for 70 m."

Amount of additional charge	=	Main piping Liquid line size φ21.3 (nominal length: 0.11)	+	Main piping Liquid line size φ18.8 (Gas line φ28.58)	+	Branch piping, Liquid line size φ15.8 (nominal length: 0.06 (Gas line φ15.88))	+	Branch piping, Liquid line size φ15.8 (nominal length: 0.02 (Gas line φ15.88))	=	3.6 (kg)
-----------------------------	---	-----------------------------------------------------------------	---	------------------------------------------------------------	---	-----------------------------------------------------------------------------------	---	-----------------------------------------------------------------------------------	---	----------

Additional charge amount for 70 m	RP200: 3.6 kg	RP250: 4.8 kg
-----------------------------------	---------------	---------------

1. Perform refrigerant piping connections for the indoor / outdoor unit while the outdoor unit's stop valve is completely closed (Initial setting), and then vacuumize the refrigerant lines through the service port of the outdoor unit.
2. Open the stop valves of the outdoor unit completely.
 This will completely connect the refrigerant circuits of the indoor and outdoor units.
 Stop valve opening method is shown on the outdoor unit's installation manual.

Note :

- Apply refrigerating machine oil over the flare seat surface. Do not apply to the threaded portion. (It will cause the flare nut to loosen.)
- Use 2 wrenches to tighten piping connection.
- Use leak detector or soapy water to check for gas leaks after connections are completed.
- For the insulation of the connection at the indoor side, make sure to use the attached insulation materials and thoroughly follow the instruction shown in the manual.
- Always use a non-oxidizing brazing material when brazing the pipes.

Adjusting the amount of refrigerant

Check additional refrigerant charging amount referring to the procedure ② below when the liquid pipe diameter of the main piping A is larger than the standard size.

- ① When the standard diameter pipe is used for the main piping A, calculate the additional refrigerant amount by referring to <Table 2> as well as the 1:1 system.
- ② When the liquid pipe diameter of the main piping A is one size larger than the standard size:
 - When the extension pipe length (main piping + branch piping) does not exceed 20m, adjustment of the refrigerant is not necessary (charge-less).
 - When the extension pipe length (main piping + branch piping) exceeds 20m, charge the amount of refrigerant that is obtained by the formula shown in <Table 7>.

If the calculation produces a negative number (i.e. a "minus" charge), additional charging is not necessary.

















Note: Apply 0 to L₁, L₂, L₃ and L₄ which correspond to the liquid pipe size that are not used.

Correcting the capacity value

When calculating the lowered capacity by the extension pipe length, use the longest length between the indoor and the outdoor units.

11-10. FUNCTION OF SWITCHES, CONNECTORS AND JUMPERS

(1) Function of switches

Type of switch	Switch	No.	Function	Action by the switch operation		Effective timing		
				ON	OFF			
Dip switch	SW1	1	Forced defrost ※1	Start	Normal	When compressor is working in heating operation. ※1		
		2	Abnormal history clear	Clear	Normal		off or operating	
		3	Refrigerant address setting					When power supply ON
		4						
		5						
		6						
		1		Test run	Operating	OFF	Under suspension	
		2		Test run mode setting	Heating	Cooling		
		Push switch	SWP	Pump down	Start	Normal	Under suspension	

※1 Forced defrost should be done as follows.

① Change the DIP SW1-1 on the outdoor controller board from OFF to ON.

② Forced defrost will start by the above operation ① if all these conditions written below are satisfied.

- Heat mode setting
- 10 minutes have passed since compressor started operating or previous compulsory defrosting finished.
- Pipe temperature is less than or equal to 8°C.

Forced defrost will finish if certain conditions are satisfied.

Forced defrost can be done if above conditions are satisfied when DIP SW1-1 is changed from OFF to ON.

After DIP SW1-1 is changed from OFF to ON, there is no problem if DIP SW1-1 is left ON or changed to OFF again.

This depends on the service conditions.

Type of Switch	Switch	No.	Function	Action by the switch operation		Effective timing																																												
				ON	OFF																																													
Dip switch	SW5	1	No function	—	—	—																																												
		2	Power failure automatic recovery *2	Auto recovery	No auto recovery	When power supply ON																																												
		3,4,5	No function	—	—	—																																												
		6	Model select	Following SW5-6 reference																																														
	SW7 *4	1	Mode select *3	Demand function	Low noise mode	Always																																												
		2	No function	—	—	—																																												
		3	Max Hz setting (cooling)	Max Hz (cooling) × 0.8	Normal	Always																																												
		4	Max Hz setting (heating)	Max Hz (heating) × 0.8	Normal	Always																																												
		5	Maximum capacity setting *5	16A	25A	When power supply ON																																												
	SW8	6	Defrost setting	For high humidity	Normal	Always																																												
		1	No function	—	—	—																																												
		2	No function	—	—	—																																												
	SW9	3	No function	—	—	—																																												
		1	No function	—	—	—																																												
		2	Function switch	Valid	Normal	Always																																												
	SW6	Model select	3,4	No function	—	—	—																																											
			1	<table border="1"> <thead> <tr> <th>MODEL</th> <th>SW6</th> <th>SW5-6</th> </tr> </thead> <tbody> <tr> <td>35</td> <td></td> <td></td> </tr> <tr> <td>50</td> <td></td> <td></td> </tr> <tr> <td>60</td> <td></td> <td></td> </tr> <tr> <td>71</td> <td></td> <td></td> </tr> <tr> <td>100V</td> <td></td> <td></td> </tr> <tr> <td>125V</td> <td></td> <td></td> </tr> <tr> <td>140V</td> <td></td> <td></td> </tr> <tr> <td>100V</td> <td></td> <td></td> </tr> <tr> <td>125V</td> <td></td> <td></td> </tr> <tr> <td>140V</td> <td></td> <td></td> </tr> </tbody> </table>	MODEL	SW6	SW5-6	35			50			60			71			100V			125V			140V			100V			125V			140V			<table border="1"> <thead> <tr> <th>MODEL</th> <th>SW6</th> <th>SW5-6</th> </tr> </thead> <tbody> <tr> <td>200VKA</td> <td></td> <td></td> </tr> <tr> <td>200VKB</td> <td></td> <td></td> </tr> <tr> <td>250V</td> <td></td> <td></td> </tr> </tbody> </table>	MODEL	SW6	SW5-6	200VKA			200VKB			250V		
			MODEL		SW6	SW5-6																																												
			35																																															
			50																																															
			60																																															
			71																																															
			100V																																															
125V																																																		
140V																																																		
100V																																																		
125V																																																		
140V																																																		
MODEL	SW6	SW5-6																																																
200VKA																																																		
200VKB																																																		
250V																																																		
2																																																		
3																																																		
4																																																		
5																																																		
6																																																		
7																																																		
8																																																		
SW5	6																																																	

The black square ■ indicates a switch position.

- *2 'Power failure automatic recovery' can be set by either remote controller or this DIP SW. If one of them is set to ON, 'Auto recovery' activates. Please set 'Auto recovery' basically by remote controller because all units do not have DIP SW. Please refer to the indoor unit installation manual.
- *3 SW7-1 is setting change over of Demand/Low noise. It is effective only in case of external input. (Local wiring is necessary. Refer to next page: Special function)
- *4 Please do not use SW7-3~6 usually. Trouble might be caused by the usage condition.
- *5 With this switch setting, the capacity decreases up to 30% under peak load condition. Thus this setting is recommended only for Air to water purposes.

(2) Function of connector

Types	Connector	Function	Action by open/ short operation		Effective timing
			Short	Open	
Connector	CN31	Emergency operation	Start	Normal	When power supply ON

Special function

(a) Low-level sound priority mode (Local wiring)

By performing the following modification, operation noise of the outdoor unit can be reduced by about 3-4 dB.

The low noise mode will be activated when a commercially available timer or the contact input of an ON/OFF switch is added to the CNDM connector (option) on the control board of the outdoor unit.

• The ability varies according to the outdoor temperature and conditions, etc.

① Complete the circuit as shown when using the external input adapter (PAC-SC36NA). (Option)

② SW7-1 (Outdoor unit control board): OFF

③ SW1 ON: Low noise mode

SW1 OFF: Normal operation

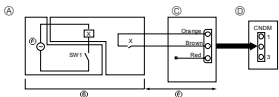

Ⓐ Circuit diagram example (low noise mode)
 Ⓑ On-site arrangement
 Ⓒ External input adapter (PAC-SC36NA)

X: Relay
 Ⓔ Outdoor unit control board
 Ⓕ Max. 10 m
 Ⓖ Power supply for relay

(b) On demand control (Local wiring)

By performing the following modification, energy consumption can be reduced to 0–100% of the normal consumption.

The demand function will be activated when a commercially available timer or the contact input of an ON/OFF switch is added to the CNDM connector (option) on the control board of the outdoor unit.

① Complete the circuit as shown when using the external input adapter (PAC-SC36NA). (Option)

② By setting SW7-1 on the control board of the outdoor unit, the energy consumption (compared to the normal consumption) can be limited as shown below.

	SW7-1	SW2	SW3	Energy consumption
Demand function	ON	OFF	OFF	100%
		ON	OFF	75%
		ON	ON	50%
		OFF	ON	0% (Stop)

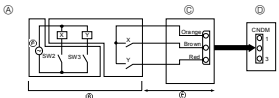

Ⓐ Circuit diagram example (Demand function)
 Ⓑ On-site arrangement
 Ⓒ External input adapter (PAC-SC36NA)

Ⓒ External input adapter (PAC-SC36NA)
 Ⓔ Outdoor unit control board
 Ⓕ Max. 10 m
 Ⓖ Power supply for relay
 X, Y: Relay

GAMA STANDARD INVERTER

PLA-RP·BA
PEAD-RP·JA
PKA-RP·HAL
PKA-RP·KAL
PCA-RP·KA
PCA-RP·HA
PSA-RP·GA

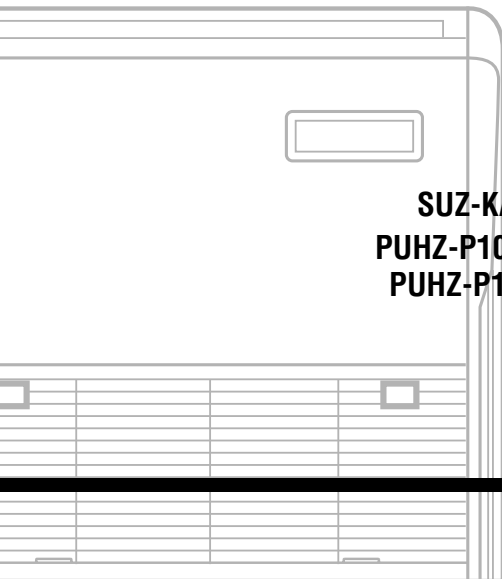

SUZ-KA35-50-60-71VA
PUHZ-P100-125-140VHA3
PUHZ-P100-125-140YHA

2-1. CEILING CASSETTE TYPE

Model name	Indoor unit	PLA-RP100BA	PLA-RP100BA3	PLA-RP125BA	PLA-RP125BA2	PLA-RP140BA2	
Cooling	Outdoor unit	PUHZ-P100VHA3	PUHZ-P100VHA3	PUHZ-P125VHA3	PUHZ-P125VHA3	PUHZ-P140VHA3	
	Capacity	Btu/h	32,100	32,100	42,000	42,000	46,400
		kW	9.4 (4.9-11.2)	9.4 (4.9-11.2)	12.3 (5.5-14.0)	12.3 (5.5-14.0)	13.6 (5.5-15.0)
	Total input	kW	3.12	3.12	4.09	4.09	5.21
	EER		3.01	3.01	3.01	3.01	2.61
	Energy label class		B	-	B	-	D
Heating	SHF		0.74	0.74	0.71	0.71	0.71
	Capacity	Btu/h	38,200	38,200	47,800	47,800	54,600
		kW	11.2 (4.5-12.5)	11.2 (4.5-12.5)	14.0 (5.0-16.0)	14.0 (5.0-16.0)	16.0 (5.0-18.0)
	Total input	kW	3.28	3.22	4.11	4.02	4.98
	COP		3.41	3.48	3.41	3.48	3.21
	Energy label class		B	-	B	-	C
Power supply	Booster heater	kW	-	-	-	-	
	Phase	φ	1				
	Cycle	Hz	50				
	Voltage	V	230				
Indoor unit	Breaker size	A	32				40
	Air flow	CMM	20-23-26-30	20-23-26-30	22-25-28-31	22-25-28-31	24-26-29-32
		CFM	70-80-90-105	70-80-90-105	77-88-100-110	77-88-100-110	83-91-103-118
		Pa	0	0	0	0	0
	Sound level	dB(A)	32-34-37-40	32-34-37-40	34-36-39-41	34-36-39-41	36-39-42-44
	External finish (Panel)		White Munsell 6.4Y 8.9/0.4				
	Dimension	W : mm	840 (950)				
	Unit (Panel)	D : mm	840 (950)				
		H : mm	298 (35)				
		W : inch	33-1/16 (37-3/8)				
D : inch		33-1/16 (37-3/8)					
H : inch		11-3/4 (1-3/8)					
Weight	kg	25 (6)	26 (6)	25 (6)	27 (6)	27 (6)	
	lbs	55 (13)	57 (13)	55 (13)	60 (13)	60 (13)	
	mm	32					
	inch	1-1/4					
Outdoor unit	Air flow	CMM	60		100		
		CFM	2,120		3,530		
	Sound level at cooling	dB(A)	50	50	51	51	52
	Sound level at heating	dB(A)	54	54	55	55	56
	External finish		Ivory Munsell 3Y 7.8/1.1				
	Dimension	W : mm	950				
Unit (Panel)	D : mm	330+30					
	H : mm	943		1350			
	W : inch	37-3/8					
	D : inch	13 + 1-3/16					
	H : inch	37-1/8		53-1/8			
Weight	kg	75		99			
	lbs	165		218			
Refrigerant pipe size	Gas side O.D.	mm	15.88				
		inch	5/8				
	Liquid side O.D.	mm	9.52				
		inch	3/8				
Refrigerant pipe length	Height difference	m	Max. 30				
	Length	m	Max. 50				

- NOTE: 1. Standard conditions (Standard):
 Cooling: Indoor: 27°C (80°F) WB, 19°C (66°F) DB; Outdoor: 35°C (95°F) WB, 24°C (75°F) DB
 Heating: Indoor: 19°C (66°F) WB; Outdoor: 7°C (45°F) WB, 6°C (43°F) DB
 Maximum piping length (maximum): 150 m (500 ft).

2. Maximum operating range

		SUWY		FURUS	
		DB (°C)	WB (°C)	DB (°C)	WB (°C)
Cooling	Upper limit	24	18	24	18
	Lower limit	5	0	5	0
Heating	Upper limit	10	15	10	15
	Lower limit	1	-1	1	-1

3. Maximum storage
 100-2000-004

4. Access panel is provided on the front panel.

5. Outdoor unit is provided on the front panel.

6. If indoor unit is not used, it is not required.

Model name	Indoor unit	PLA-RP100BA	PLA-RP100BA3	PLA-RP125BA	PLA-RP125BA2	PLA-RP140BA2	
	Outdoor unit	PUHZ-P100YHA	PUHZ-P100YHA	PUHZ-P125YHA	PUHZ-P125YHA	PUHZ-P140YHA	
Cooling	Capacity	Btu/h	32,100	32,100	42,000	42,000	46,400
		kW	9.4 (4.9-11.2)	9.4 (4.9-11.2)	12.3 (5.5-14.0)	12.3 (5.5-14.0)	13.6 (5.5-15.0)
	Total input	kW	3.12	3.12	4.09	4.09	5.21
	EER		3.01	3.01	3.01	3.01	2.61
	Energy label class		B	-	B	-	D
Heating	Capacity	Btu/h	38,200	38,200	47,800	47,800	54,600
		kW	11.2 (4.5-12.5)	11.2 (4.5-12.5)	14.0 (5.0-16.0)	14.0 (5.0-16.0)	16.0 (5.0-18.0)
	Total input	kW	3.28	3.22	4.11	4.02	4.98
	COP		3.41	3.48	3.41	3.48	3.21
	Energy label class		B	-	B	-	C
Power supply	Booster heater	kW	-	-	-	-	-
	Phase	φ			3		
	Cycle	Hz			50		
	Voltage	V			400		
Indoor unit	Breaker size	A			16		
	Air flow	CMM	20-23-26-30	20-23-26-30	22-25-28-31	22-25-28-31	24-26-29-32
		CFM					
	Sound level	Pa	0	0	0	0	0
		dB(A)	32-34-37-40	32-34-37-40	34-36-39-41	34-36-39-41	36-39-42-44
	External finish (Panel)		White Munsell 6.4Y 8.9/0.4				
	Dimension	W : mm	840 (950)				
		D : mm	840 (950)				
	Unit (Panel)	H : mm	298 (35)				
		W : inch	33-1/16 (37-3/8)				
	Dimension	D : inch	33-1/16 (37-3/8)				
		H : inch	11-3/4 (1-3/8)				
	Weight	kg	25 (6)	26 (6)	25 (6)	27 (6)	27 (6)
lbs		55 (13)	57 (13)	55 (13)	60 (13)	60 (13)	
Flight clearance (mm)	mm	32					
	inch	1-1/4					
Outdoor unit	Air flow	CMM	60		100		
		CFM	2,120		3,530		
	Sound level at cooling	dB(A)	50	50	51	51	52
		dB(A)	54	54	55	55	56
	External finish		Ivory Munsell 3Y 7.8/1.1				
Dimension	W : mm	950					
	D : mm	330+30					
Dimension	H : mm	943			1350		
	W : inch	37-3/8					
Dimension	D : inch	13 + 1-3/16					
	H : inch	37-1/8		53-1/8			
Weight	kg	77		101			
	lbs	169		222			
Refrigerant pipe size	Gas side O.D.	mm	15.88				
		inch	5/8				
	Liquid side O.D.	mm	9.52				
		inch	3/8				
Refrigerant pipe length	Height difference	m	Max. 30				
	Length	m	Max. 50				

NOTE: 1. Rating conditions (ISO T1)

Cooling Indoor : D.B. 27°C (80°F) W.B. 19°C (66°F) Outdoor : D.B. 35°C (95°F) W.B. 24°C (75°F)

Heating Indoor : D.B. 20°C (68°F) Outdoor : D.B. 7°C (45°F) W.B. 6°C (43°F)

Refrigerant piping length (one way) : 5m (16ft.)

2. Guaranteed operating range

		Indoor	Outdoor
Cooling	Upper limit	D.B. 35°C W.B. 22.5°C	D.B. 46°C
	Lower limit	D.B. 19°C W.B. 15°C	D.B. -5°C ※
Heating	Upper limit	D.B. 28°C	D.B. 21°C W.B. 15°C
	Lower limit	D.B. 17°C	D.B. -15°C W.B. -15°C

3. Guaranteed voltage

Indoor unit 198-264V, 50Hz

Outdoor unit 342-457V, 50Hz

4. Above data are based on the indicated voltage.

Indoor unit Single phase 230V 50Hz

Outdoor unit 3 phase 400V 50Hz

* If optional air protect guide installed. D.B. -15°C

2-2. CEILING-CONCEALED TYPE

Model name	Indoor unit	PEAD-RP100JA(L)	PEAD-RP125JA(L)	PEAD-RP140JA(L)	
	Outdoor unit	PUHZ-P100VHA3	PUHZ-P125VHA3	PUHZ-P140VHA3	
Cooling	Capacity	Btu/h	32,100	42,000	46,400
		kW	9.4 (4.9-11.2)	12.3 (6.5-14.0)	13.6 (5.5-15.0)
	Total input	kW	3.04 (3.02)	4.22 (4.20)	4.52 (4.50)
	EER		3.09 (3.11)	2.91 (2.93)	3.01 (3.02)
	Energy label class		B	C	B
Heating	Capacity	Btu/h	38,200	47,800	54,600
		kW	11.2 (4.5-12.5)	14.0 (5.0-16.0)	16.0 (5.0-18.0)
	Total input	kW	3.10	3.87	4.43
	COP		3.61	3.62	3.61
	Energy label class		A	A	A
Power supply	Booster heater	kW	-	-	-
	Phase	φ	1		
	Cycle	Hz	50		
	Voltage	V	230		
	Breaker size	A	32		40
Indoor unit	Air flow (Low-Mid-High)	CMM	24 - 29 - 34	29.5 - 35.5 - 42	32 - 39 - 46
		CFM	847-1024-1201	1042-1253-1483	1130-1377-1624
	External pressure	Pa	35 / 50 / 70 / 100 / 150		
	Sound level (Low-Mid-High)	dB(A)	29 - 34 - 38	33 - 36 - 40	34 - 38 - 43
		External finish	Galvanized sheets		
	Dimension	W : mm	1400		1600
		D : mm	732		
		H : mm	250		
		W : inch	55-1/8		63
		D : inch	28-7/8		
		H : inch	9-7/8		
	Weight	kg	41 (40)	43 (42)	47 (46)
		lbs	91 (89)	95 (93)	104 (102)
Field drain pipe O.D.	mm	32			
	inch	1-1/4			
Outdoor unit	Air flow	CMM	60	100	
		CFM	2,120	3,530	
	Sound level at cooling	dB(A)	50	51	52
	Sound level at heating	dB(A)	54	55	56
	External finish	Ivory Munsell 3Y 7.8/1.1			
	Dimension	W : mm	950		
		D : mm	330(+30)		
		H : mm	943	1350	
		W : inch	37-3/8		
		D : inch	13 + 1-3/16		
H : inch		37-1/8	53-1/8		
Weight	kg	75	99		
	lbs	165	218		
Refrigerant pipe size	Gas side O.D.	mm	15.88		
		inch	5/8		
	Liquid side O.D.	mm	9.52		
		inch	3/8		
Refrigerant pipe length	Height difference	m	Max. 30		
	Length	m	Max. 50		

NOTE: 1. Rating conditions (ISO T1)

Cooling Indoor : D.B. 27°C (80°F) W.B. 19°C (66°F) Outdoor : D.B. 35°C (95°F) W.B. 24°C (75°F)

Heating Indoor : D.B. 20°C (68°F) Outdoor : D.B. 7°C (45°F) W.B. 6°C (43°F)

Refrigerant piping length (one way) : 5m (16ft.)

2. Guaranteed operating range

3. Guaranteed voltage
198-264V, 50Hz

		Indoor	Outdoor
Cooling	Upper limit	D.B. 35°C, W.B. 22.5°C	D.B. 46°C
	Lower limit	D.B. 19°C, W.B. 15°C	D.B. -5°C ※
Heating	Upper limit	D.B. 28°C	D.B. 21°C, W.B. 15°C
	Lower limit	D.B. 17°C	D.B. -15°C, W.B. -15°C

4. Above data are based on the indicated voltage.

Indoor unit Single phase 230V 50Hz

Outdoor unit Single phase 230V 50Hz

※ If optional air protect guide is installed : D.B. -11°C

Model name	Indoor unit	PEAD-RP100JA(L)	PEAD-RP125JA(L)	PEAD-RP140JA(L)	
Cooling	Outdoor unit	PUHZ-P100YHA	PUHZ-P125YHA	PUHZ-P140YHA	
	Capacity	Btu/h	32,100	42,000	46,400
		kW	9.4 (4.9-11.2)	12.3 (5.5-14.0)	13.6 (5.5-15.0)
	Total input	kW	3.04 (3.02)	4.22 (4.20)	4.52 (4.50)
	EER		3.09 (3.11)	2.91 (2.93)	3.01 (3.02)
	Energy label class		B	C	B
SHF		0.85	0.85	0.84	
Heating	Capacity	Btu/h	38,200	47,800	54,600
		kW	11.2 (4.5-12.5)	14.0 (5.0-16.0)	16.0 (5.0-18.0)
	Total input	kW	3.10	3.87	4.43
	COP		3.61	3.62	3.61
	Energy label class		A	A	A
	Booster heater	kW	-	-	-
Power supply	Phase	φ	3		
	Cycle	Hz	50		
	Voltage	V	400		
	Breaker size	A	16		
Indoor unit	Air flow	CMM	24 - 29 - 34	29.5 - 35.5 - 42	32 - 39 - 46
		CFM	847-1024-1201	1042-1253-1483	1130-1377-1624
	External pressure	Pa	35 / 50 / 70 / 100 / 150		
	Sound level	dB(A)	29 - 34 - 38	33 - 36 - 40	34 - 38 - 43
	External finish		Galvanized sheets		
	Dimension	W : mm	1400		1600
		D : mm	732		
		H : mm	250		
		W : inch	55-1/8		63
		D : inch	28-7/8		
		H : inch	9-7/8		
	Weight	kg	41 (40)	43 (42)	47 (46)
		lbs	91 (89)	95 (93)	104 (102)
	Field drain pipe O.D.	mm	32		
inch		1-1/4			
Outdoor unit	Air flow	CMM	60	100	
		CFM	2,120	3,530	
	Sound level at cooling	dB(A)	50	51	52
	Sound level at heating	dB(A)	54	55	56
	External finish		Ivory Munsell 3Y 7.8/1.1		
	Dimension	W : mm	950		
		D : mm	330(+30)		
		H : mm	943	1350	
		W : inch	37-3/8		
		D : inch	13 + 1-3/16		
H : inch		37-1/8	53-1/8		
Weight	kg	77	101		
	lbs	169	222		
Refrigerant pipe size	Gas side O.D.	mm	15.88		
		inch	5/8		
	Liquid side O.D.	mm	9.52		
		inch	3/8		
Refrigerant pipe length	Height difference	m	Max. 30		
	Length	m	Max. 50		

- NOTE:**
- Rating conditions (ISO T1)
Cooling Indoor: D.B. 27°C (80°F) W.B. 19°C (66°F) Outdoor: D.B. 35°C (95°F) W.B. 24°C (75°F)
Heating Indoor: D.B. 20°C (68°F) Outdoor: D.B. 7°C (45°F) W.B. 6°C (43°F)
Refrigerant piping length (one way) : 5m (16ft)
 - Guaranteed operating range

	Indoor	Outdoor
Cooling	Upper limit D.B. 35°C, W.B. 22.5°C	D.B. 46°C
	Lower limit D.B. 19°C, W.B. 15°C	D.B. -5°C ※
Heating	Upper limit D.B. 28°C	D.B. 21°C, W.B. 15°C
	Lower limit D.B. 17°C	D.B. -15°C, W.B. -15°C
 - Guaranteed voltage
Indoor unit 198-264V, 50Hz
Outdoor unit 342-457V, 50Hz
 - Above data are based on the indicated voltage.
Indoor unit Single phase 230V 50Hz
Outdoor unit 3 phase 400V 50Hz
※ If optional air protect guide installed. D.B. -15°C

Model name	Indoor unit	PEA-RP200GA		PEA-RP250GA				
	Outdoor unit	PUHZ-P200YHA3		PUHZ-P250YHA3				
Cooling	Capacity	Btu/h	65,000		75,000			
		kW	19.0(9.0-22.4)		22.0(11.2-28.0)			
	Total input	kW	7.21	8.44				
	EER		2.64	2.61				
	Energy label class		D	D				
Heating	Capacity	Btu/h	76,000		92,000			
		kW	22.4(9.5-25.0)		27.0(12.5-31.5)			
	Total input	kW	7.36	8.47				
	COP		3.04	3.19				
	Energy label class		D	D				
Power supply	Booster heater	kW	-		-			
	Phase	ϕ			3			
	Cycle	Hz			50			
	Voltage	V			400			
Indoor unit	Breaker size	A	Indoor 15 / Outdoor 32					
	Air flow	CMM	52 - 65		64 - 80			
		(Low-High)	CFM	1835 - 2295		2260 - 2825		
	External pressure	Pa	150					
	Sound level	(Low-High)	dB(A)	48-51		49 - 52		
				External finish			Galvanized steel	
	Dimension	W : mm	D : mm	H : mm	1400		1600	
					634			
					400			
					W : inch		55-1/8	63
					D : inch		25	
					H : inch		15-3/4	
	Weight	kg	70	77				
lbs		155	170					
Unit drain pipe		R1						
Outdoor unit	Air flow	CMM	130					
		CFM	4590					
	Sound level at cooling	dB(A)	59					
	Sound level at heating	dB(A)	59					
	External finish		Ivory Munself 3Y 7.8/1.1					
	Dimension	W : mm	D : mm	H : mm	950			
					330*30			
					1350			
					W : inch		37-3/8	
					D : inch		13 + 1-3/16	
					H : inch		53-1/8	
Weight	kg	126	133					
	lbs	278	294					
Refrigerant pipe size	Gas side O.D.	mm	25.4					
		inch	1					
	Liquid side O.D.	mm	9.52	12.7				
		inch	3/8	1/2				
Refrigerant pipe length	Height difference	m	Max. 30					
	Length	m	Max. 70					

NOTE: 1. Rating conditions (ISO T1)

Cooling Indoor : D.B. 27°C (80°F) W.B. 19°C (66°F) Outdoor : D.B. 35°C (95°F) W.B. 24°C (75°F)

Heating Indoor : D.B. 20°C (68°F) Outdoor : D.B. 7°C (45°F) W.B. 6°C (43°F)

Refrigerant piping length (one way) : 5m (16ft.)

2. Guaranteed operating range

		Indoor		Outdoor	
Cooling	Upper limit	D.B. 35°C	W.B. 22.5°C	D.B. 46°C	
	Lower limit	D.B. 19°C	W.B. 15°C	D.B. -5°C	
Heating	Upper limit	D.B. 28°C		D.B. 21°C	
	Lower limit	D.B. 17°C		D.B. -11°C	

3. Guaranteed voltage

342-457V, 50Hz

4. Above data are based on the indicated voltage.

Indoor unit 3 phase 400V 50Hz

Outdoor unit 3 phase 400V 50Hz

※1. If optional air protect guide is installed : D.B. -15°C

Model name	Indoor unit		PEA-RP400GA	PEA-RP500GA
Cooling	Outdoor unit		PUHZ-P200YHA3*2	
	Capacity	Btu/h	130,000	150,000
		kW	38.0(18.0-44.8)	44.0(22.4-56.0)
	Total input	kW	13.97	17.36
	EER		2.72	2.53
	Energy label class		-	-
SHF		0.75	0.77	
Heating	Capacity		153,000	184,000
	Total input	Btu/h	44.8(19.0-50.0)	54.0(25.0-63.0)
		kW	14.27	17.42
	COP		3.14	3.10
	Energy label class		-	-
	Booster heater	kW	-	-
Power supply	Phase	φ	3	
	Cycle	Hz	50	
	Voltage	V	400	
	Breaker size	A	Indoor 15 / Outdoor 32*2	
Indoor unit	Air flow	CMM	120	160
	(High)	CFM	4240	5650
	External pressure	Pa	150	
	Sound level (High)	dB(A)	52	53
	External finish		Galvanized steel	
	Dimension	W : mm	1947	
		D : mm	764	
		H : mm	595	
		W : inch	79-11/16	
		D : inch	30-1/8	
		H : inch	23-7/16	
Weight	kg	130	133	
	lbs	286	293	
Unit drain pipe		R1		
Outdoor unit (Per 1 outdoor unit)	Air flow	CMM	130	
		CFM	4590	
	Sound level at cooling	dB(A)	59	
	Sound level at heating	dB(A)	59	
	External finish		Ivory Munsell 3Y 7.8/1.1	
	Dimension	W : mm	950	
		D : mm	330*30	
		H : mm	1350	
		W : inch	37-3/8	
		D : inch	13 + 1-3/16	
		H : inch	53-1/8	
Weight	kg	126	133	
	lbs	278	294	
Refrigerant pipe size	Gas side O.D.	mm	25.4 × 2	
		inch	1 × 2	
	Liquid side O.D.	mm	9.52 × 2	12.7 × 2
		inch	3/8 × 2	1/2 × 2
Refrigerant pipe length	Height difference	m	Max. 30	
	Length	m	Max. 70 (per 1 outdoor unit)	

NOTE: 1. Rating conditions (ISO T1)

Cooling Indoor : D.B. 27°C (80°F) WB. 19°C (66°F) Outdoor : D.B. 35°C (95°F) WB. 24°C (75°F)

Heating Indoor : D.B. 20°C (68°F) Outdoor : D.B. 7°C (45°F) WB. 6°C (43°F)

Refrigerant piping length (one way) : 5m (16ft.)

2. Guaranteed operating range

	Indoor		Outdoor
Cooling	Upper limit	D.B. 35°C, W.B. 22.5°C	D.B. 46°C
	Lower limit	D.B. 19°C, W.B. 15°C	D.B. -5°C ※1
Heating	Upper limit	D.B. 28°C	D.B. 21°C, W.B. 15°C
	Lower limit	D.B. 17°C	D.B. -11°C, W.B. -12°C

3. Guaranteed voltage

342~457V, 50Hz

4. Above data are based on the indicated voltage.

Indoor unit 3 phase 400V 50Hz

Outdoor unit 3 phase 400V 50Hz

※1. If optional air protect guide is installed : D.B. -15°C

2-3. WALL-MOUNTED TYPE

Model name	Indoor unit		PKA-RP100KAL	PKA-RP100KAL
	Outdoor unit		PUHZ-P100VHA3	PUHZ-P100YHA
Cooling	Capacity	Btu/h	32,100	
		kW	9.4 (4.9-11.2)	
	Total input	kW	3.12	
	EER		3.01	
	Energy label class		B	
Heating	Capacity	Btu/h	38,200	
		kW	11.2 (4.5-12.5)	
	Total input	kW	3.49	
	COP		3.21	
	Energy label class		C	
Power supply	Booster heater	kW	-	
	Phase	φ	1	3
	Cycle	Hz	50	50
	Voltage	V	230	400
Indoor unit	Breaker size	A	32	16
	Air flow	CMM	20 - 23 - 26	
		CFM	705 - 810 - 920	
	External pressure	Pa	0	
	Sound level (Low-Mid-High)	dB(A)	41 - 45 - 49	
	External finish		Munsell 1.0Y 9.2/0.2	
	Dimension	W : mm	1170	
		D : mm	295	
		H : mm	365	
		W : inch	46-1/16	
		D : inch	11-5/8	
		H : inch	14-3/8	
	Weight	kg	21	
		lbs	46	
	Field drain pipe I.D.	mm	16	
inch		5/8		
Outdoor unit	Air flow	CMM	60	
		CFM	2,120	
	Sound level at cooling	dB(A)	50	
	Sound level at heating	dB(A)	54	
	External finish		Ivory Munsell 3Y 7.8/1.1	
	Dimension	W : mm	950	
		D : mm	330+30	
		H : mm	943	
		W : inch	37-3/8	
		D : inch	13 + 1.3/16	
H : inch		37-1/8		
Weight	kg	75	77	
	lbs	165	169	
Refrigerant pipe size	Gas side O.D.	mm	15.88	
		inch	5/8	
	Liquid side O.D.	mm	9.52	
		inch	3/8	
Refrigerant pipe length	Height difference	m	Max. 30	
	Length	m	Max. 50	

NOTE: 1. Rating conditions (ISO T1)

Cooling Indoor : D.B. 27°C (80°F) W.B. 19°C (66°F) Outdoor : D.B. 35°C (95°F) W.B. 24°C (75°F)

Heating Indoor : D.B. 20°C (68°F) Outdoor : D.B. 7°C (45°F) W.B. 6°C (43°F)

Refrigerant piping length (one way) : 5m (16ft.)

2. Guaranteed operating range

3. Guaranteed voltage

198-264V, 50Hz (V) / 342-457V, 50Hz (Y)

4. Above data are based on the indicated voltage.

Indoor unit Single phase 230V 50Hz

Outdoor unit V : Single phase 230V 50Hz

Y : 3 phase 400V 50Hz

⊃1. If optional air protect guide is installed : D.B. -15°C

		Indoor	Outdoor
Cooling	Upper limit	D.B. 35°C, W.B. 22.5°C	D.B. 46°C
	Lower limit	D.B. 19°C, W.B. 15°C	D.B. -5°C
Heating	Upper limit	D.B. 28°C	D.B. 21°C, W.B. 15°C
	Lower limit	D.B. 17°C	D.B. -15°C, W.B. -15°C

2-4. CEILING-SUSPENDED TYPE

Model name	Indoor unit		PCA-RP100KA	PCA-RP125KA	PCA-RP140KA	
	Outdoor unit		PUHZ-P100VHA3	PUHZ-P125VHA3	PUHZ-P140VHA3	
Cooling	Capacity	Btu/h	32,100	42,000	46,400	
		kW	9.4(4.9-11.2)	12.3(5.5-14.0)	13.6(5.5-15.0)	
	Total input	kW	3.13	4.09	4.84	
	EER		3.00	3.01	2.81	
	Energy label class			C	B	C
	SHF			0.77	0.72	0.71
Heating	Capacity	Btu/h	38,200	47,800	54,600	
		kW	11.2(4.5-12.5)	14.0(5.0-16.0)	16.0(5.0-18.0)	
	Total input	kW	3.28	4.12	4.69	
	COP		3.41	3.40	3.41	
	Energy label class			B	C	B
	Booster heater		kW	-	-	-
Power supply	Phase	φ	1			
	Cycle	Hz	50			
	Voltage	V	230			
	Breaker size	A	32		40	
	Air flow	CMM	22 - 24 - 26 - 28	23 - 25 - 27 - 29	24 - 26 - 29 - 32	
(Low-Medium2-Medium1-High)	CFM	775-850-920-990	810-885-955-1025	850-920-1025-1130		
External pressure	Pa	0				
Sound level	dB(A)	(Low-Medium2-Medium1-High)	37 - 39 - 41 - 43	39 - 41 - 43 - 45	41 - 43 - 45 - 48	
External finish			White Munsell 6.4Y 8.9/0.4			
Dimension	W : mm	1600				
		D : mm	680			
		H : mm	230			
		W : inch	63			
		D : inch	26-3/4			
		H : inch	9-1/16			
	Weight	kg	36	38	39	
lbs		79	84	86		
Field drain pipe O.D.	mm	26				
	inch	1				
Outdoor unit	Air flow	CMM	60	100		
		CFM	2,120	3,530		
	Sound level at cooling	dB(A)	50	51	52	
	Sound level at heating	dB(A)	54	55	56	
	External finish		Ivory Munsell 3Y 7.8/1.1			
	Dimension	W : mm	950			
D : mm			330			
H : mm			943	1350		
W : inch			37-3/8			
D : inch			13 + 1-3/16			
H : inch			37-1/8	53-1/8		
Weight	kg	75	99			
	lbs	165	218			
Refrigerant pipe size	Gas side O.D.	mm	15.88			
		inch	5/8			
	Liquid side O.D.	mm	9.52			
		inch	3/8			
Refrigerant pipe length	Height difference	m	Max. 30			
	Length	m	Max. 50			

NOTE: 1. Rating conditions (ISO T1)

Cooling Indoor: D.B. 27°C (80°F) W.B. 19°C (66°F) Outdoor: D.B. 35°C (95°F) W.B. 24°C (75°F)

Heating Indoor: D.B. 20°C (68°F) Outdoor: D.B. 7°C (45°F) W.B. 6°C (43°F)

Refrigerant piping length (one way): 5m (16ft.)

2. Guaranteed operating range

	Indoor		Outdoor
Cooling	Upper limit	D.B. 35°C, W.B. 22.6°C	D.B. 46°C
	Lower limit	D.B. 19°C, W.B. 15°C	D.B. -5°C
Heating	Upper limit	D.B. 28°C	D.B. 21°C, W.B. 16°C
	Lower limit	D.B. 17°C	D.B. -15°C, W.B. -15°C

3. Guaranteed voltage
198-264V, 50Hz

4. Above data are based on the indicated voltage.

Indoor unit Single phase 230V 50Hz

Outdoor unit Single phase 230V 50Hz

⊗ If optional air protect guide is installed: D.B. -15°C

Model name	Indoor unit		PCA-RP100KA	PCA-RP125KA	PCA-RP140KA
	Outdoor unit		PUHZ-P100YHA	PUHZ-P125YHA	PUHZ-P140YHA
Cooling	Capacity	Btu/h	32.100	42.000	46.400
		kW	9.4(4.9-11.2)	12.3(5.5-14.0)	13.6(5.5-15.0)
	Total input	kW	3.13	4.09	4.84
	EER		3.00	3.01	2.81
	Energy label class		C	B	C
Heating	Capacity	Btu/h	38.200	47.800	54.600
		kW	11.2(4.5-12.5)	14.0(5.0-16.0)	16.0(5.0-18.0)
	Total input	kW	3.28	4.12	4.69
	COP		3.41	3.40	3.41
	Energy label class		B	C	B
Power supply	Booster heater	kW	-	-	-
	Phase	φ		3	
	Cycle	Hz		50	
	Voltage	V		400	
Indoor unit	Breaker size	A		16	
	Air flow	CMM	22 - 24 - 26 - 28	23 - 25 - 27 - 29	24 - 26 - 29 - 32
	(Low-Medium2-Medium1-High)	CFM	775-850-920-990	810-885-955-1025	850-920-1025-1130
	External pressure	Pa		0	
	Sound level	dB(A)	37 - 39 - 41 - 43	39 - 41 - 43 - 45	41 - 43 - 45 - 48
	(Low-Medium2-Medium1-High)				
	External finish		White Munsell 6.4Y 8.9/0.4		
	Dimension	W : mm		1600	
		D : mm		680	
		H : mm		230	
		W : inch		63	
		D : inch		26-3/4	
		H : inch		9-1/16	
	Weight	kg	36	38	39
		lbs	79	84	86
Field drain pipe O.D.	mm		26		
	inch		1		
Outdoor unit	Air flow	CMM	60	100	
		CFM	2.120	3.530	
	Sound level at cooling	dB(A)	50	51	52
	Sound level at heating	dB(A)	54	55	56
	External finish		Ivory Munsell 3Y 7.8/1.1		
	Dimension	W : mm		950	
		D : mm		330 (+30)	
		H : mm	943		1350
		W : inch		37-3/8	
		D : inch		13 + 1-3/16	
H : inch		37-1/8		53-1/8	
Weight	kg	77		101	
	lbs	169		222	
Refrigerant pipe size	Gas side O.D.	mm		15.88	
		inch		5/8	
	Liquid side O.D.	mm		9.52	
		inch		3/8	
Refrigerant pipe length	Height difference	m		Max. 30	
	Length	m		Max. 50	

NOTE: 1. Rating conditions (ISO T1)

Cooling Indoor: D.B. 27°C (80°F) W.B. 19°C (66°F) Outdoor: D.B. 35°C (95°F) W.B. 24°C (75°F)
 Heating Indoor: D.B. 20°C (68°F) Outdoor: D.B. 7°C (45°F) W.B. 6°C (43°F)

Refrigerant piping length (one way): 5m (16ft.)

2. Guaranteed operating range

	Indoor		Outdoor	
Cooling	Upper limit	D.B. 35°C, W.B. 22.5°C	D.B. 46°C	
	Lower limit	D.B. 19°C, W.B. 15°C	D.B. -5°C	※
Heating	Upper limit	D.B. 28°C	D.B. 21°C, W.B. 15°C	
	Lower limit	D.B. 17°C	D.B. -15°C, W.B. -15°C	

3. Guaranteed voltage

Indoor unit 198-264V, 50Hz
 Outdoor unit 342-457V, 50Hz

4. Above data are based on the indicated voltage.

Indoor unit Single phase 230V 50Hz
 Outdoor unit 3 phase 400V 50Hz

※ If optional air protect guide installed. D.B. -15°C

Model name	Indoor unit		PCA-RP125HA	PCA-RP125HA
	Outdoor unit		PUHZ-P125VHA3	PUHZ-P125YHA
Cooling	Capacity	Btu/h	42,000	
		kW	12.3 (5.5-14.0)	
	Total input	kW	4.38	
	EER		2.81	
	Energy label class		C	
Heating	Capacity	Btu/h	47,100	
		kW	13.8 (5.0-16.0)	
	Total input	kW	4.30	
	COP		3.21	
	Energy label class		C	
Power supply	Booster heater	kW	-	
	Phase	φ	1	3
	Cycle	Hz	50	50
	Voltage	V	230	400
	Breaker size	A	32	16
Indoor unit	Air flow (Low-High)	CMM	30-38	
		CFM	1060-1350	
	External pressure	Pa	0	
	Sound level (Low-High)	dB(A)	44-50	
	External finish		Stainless steel	
	Dimension	W : mm	1520	
		D : mm	650	
		H : mm	280	
		W : inch	59-7/8	
		D : inch	25-5/8	
	Weight	H : inch	11	
		kg	56	
	Field drain pipe O.D.	lbs	124	
mm		26		
inch		1		
Outdoor unit	Air flow	CMM	100	
		CFM	3,530	
	Sound level at cooling	dB(A)	51	
	Sound level at heating	dB(A)	55	
	External finish		Ivory Munsell 3Y 7.8/1.1	
	Dimension	W : mm	950	
		D : mm	330+30	
		H : mm	1350	
		W : inch	37-3/8	
		D : inch	13 + 1-3/16	
Weight	H : inch	53-1/8		
	kg	99	101	
Refrigerant pipe size	Gas side O.D.	lbs	218	222
		mm	15.88	
	Liquid side O.D.	inch	5/8	
		mm	9.52	
	Refrigerant pipe length	inch	3/8	
		Height difference	m	Max. 30
	Length	m	Max. 50	

NOTE: 1. Rating conditions (ISO T1)

Cooling Indoor : D.B. 27°C (80°F) W.B. 19°C (66°F) Outdoor : D.B. 35°C (95°F) W.B. 24°C (75°F)

Heating Indoor : D.B. 20°C (68°F) Outdoor : D.B. 7°C (45°F) W.B. 6°C (43°F)

Refrigerant piping length (one way) : 5m (16ft.)

2. Guaranteed operating range

		Indoor		Outdoor	
		D.B. 35°C, W.B. 22.5°C	D.B. 46°C	D.B. -5°C	*
Cooling	Upper limit	D.B. 19°C, W.B. 15°C	D.B. -5°C	*	
	Lower limit	D.B. 28°C	D.B. 21°C, W.B. 15°C		
Heating	Upper limit	D.B. 17°C	D.B. -15°C, W.B. -15°C		
	Lower limit				

3. Guaranteed voltage

198-264V, 50Hz (P125Y : 342-457V, 50Hz)

4. Above data are based on the indicated voltage.

Indoor unit Single phase 230V 50Hz

Outdoor unit V: Single phase 230V 50Hz,

Y: 3 phase 400V 50Hz

* If optional air protect guide installed. D.B. -15°C

2-5. FLOOR STANDING TYPE

Model name	Indoor unit	PSA-RP100GA	PSA-RP125GA	PSA-RP140GA	
	Outdoor unit	PUHZ-P100VHA3	PUHZ-P125VHA3	PUHZ-P140VHA3	
Cooling	Capacity	Btu/h	32,100	42,000	46,400
		kW	9.4(4.9-11.2)	12.3(5.5-14.0)	13.6(5.5-15.0)
	Total input	kW	3.12	4.38	5.64
	EER		3.01	2.81	2.41
	Energy label class		B	C	E
Heating	Capacity	Btu/h	38,200	47,800	54,600
		kW	11.2(4.5-12.5)	14.0(5.0-16.0)	16.0(5.0-18.0)
	Total input	kW	3.28	4.98	5.69
	COP		3.41	2.81	2.81
	Energy label class		B	D	D
Power supply	Booster heater	kW	-	-	-
	Phase	φ		1	
	Cycle	Hz		50	
	Voltage	V		230	
Indoor unit	Breaker size	A	32	40	
	Air flow	CMM	24-31	26-33	27-35
	(Low-High)	CFM	850-1060	920-1165	955-1240
	External pressure	Pa		0	
	Sound level	dB(A)	44-49	46-51	47-52
	(Low-High)				
	External finish		White Munsell 0.70Y 8.59/0.97		
	Dimension	W : mm	600		
		D : mm	350		
		H : mm	1900		
		W : inch	23-5/8		
		D : inch	13-3/4		
		H : inch	74-13/16		
	Weight	kg	51		53
		lbs	112		117
Field drain pipe I.D.	mm	20			
	inch	13/16			
Outdoor unit	Air flow	CMM	60	100	
		CFM	2,120	3,530	
	Sound level at cooling	dB(A)	50	51	52
	Sound level at heating	dB(A)	54	55	56
	External finish		Ivory Munsell 3Y 7.8/1.1		
	Dimension	W : mm	950		
		D : mm	330+30		
		H : mm	943	1350	
		W : inch	37-3/8		
		D : inch	13 + 1-3/16		
H : inch		37-1/8	53-1/8		
Weight	kg	75	99		
	lbs	165	218		
Refrigerant pipe size	Gas side O.D.	mm	15.88		
		inch	5/8		
	Liquid side O.D.	mm	9.52		
		inch	3/8		
Refrigerant pipe length	Height difference	m	Max. 30		
	Length	m	Max. 50		

NOTE: 1. Rating conditions (ISO T1)

Cooling Indoor : D.B. 27°C (80°F) W.B. 19°C (66°F) Outdoor : D.B. 35°C (95°F) W.B. 24°C (75°F)

Heating Indoor : D.B. 20°C (68°F) Outdoor : D.B. 7°C (45°F) W.B. 6°C (43°F)

Refrigerant piping length (one way) : 5m (16ft.)

2. Guaranteed operating range

3. Guaranteed voltage
198-264V, 50Hz

4. Above data are based on the indicated voltage.

		Indoor	Outdoor
Cooling	Upper limit	D.B. 35°C, W.B. 22.5°C	D.B. 46°C
	Lower limit	D.B. 19°C, W.B. 15°C	D.B. -5°C ※
Heating	Upper limit	D.B. 28°C	D.B. 21°C, W.B. 15°C
	Lower limit	D.B. 17°C	D.B. -15°C, W.B. -15°C

Indoor unit Single phase 230V 50Hz

Outdoor unit Single phase 230V 50Hz

※ If optional air protect guide is installed : D.B. -15°C

Model name	Indoor unit	PSA-RP100GA	PSA-RP125GA	PSA-RP140GA	
Cooling	Outdoor unit	PUHZ-P100YHA	PUHZ-P125YHA	PUHZ-P140YHA	
	Capacity	Btu/h	32,100	42,000	46,400
		kW	9.4(4.9-11.2)	12.3(5.5-14.0)	13.6(5.5-15.0)
	Total input	kW	3.12	4.38	5.64
	EER		3.01	2.81	2.41
	Energy label class		B	C	E
SHF		0.83	0.76	0.75	
Heating	Capacity	Btu/h	38,200	47,800	54,600
	Total input	kW	11.2(4.5-12.5)	14.0(5.0-16.0)	16.0(5.0-18.0)
		kW	3.28	4.98	5.69
	COP		3.41	2.81	2.81
	Energy label class		B	D	D
	Booster heater	kW	-	-	-
Power supply	Phase	φ	3		
	Cycle	Hz	50		
	Voltage	V	400		
	Breaker size	A	16		
	Indoor unit	Air flow (Low-High)	CMM	24-31	26-33
External pressure		CFM	850-1060	920-1165	955-1240
		Pa	0		
Sound level (Low-High)		dB(A)	44-49	46-51	47-52
External finish		White Munsell 0.70Y 8.59/0.97			
Dimension		W : mm	600		
		D : mm	350		
		H : mm	1900		
		W : inch	23-5/8		
		D : inch	13-3/4		
		H : inch	74-13/16		
Weight		kg	51		53
		lbs	112		117
Field drain pipe I.D.		mm	20		
	inch	13/16			
Outdoor unit	Air flow	CMM	60	100	
		CFM	2,120	3,530	
	Sound level at cooling	dB(A)	50	51	52
	Sound level at heating	dB(A)	54	55	56
	External finish	Ivory Munsell 3Y 7.8/1.1			
	Dimension	W : mm	950		
		D : mm	330+30		
		H : mm	943	1350	
		W : inch	37-3/8		
		D : inch	13 + 1-3/16		
H : inch		37-1/8	53-1/8		
Weight	kg	77	101		
	lbs	169	222		
Refrigerant pipe size	Gas side O.D.	mm	15.88		
		inch	5/8		
	Liquid side O.D.	mm	9.52		
		inch	3/8		
Refrigerant pipe length	Height difference	m	Max. 30		
	Length	m	Max. 50		

NOTE: 1. Rating conditions (ISO T1)
Cooling Indoor : D.B. 27°C (80°F) W.B. 19°C (66°F) Outdoor : D.B. 35°C (95°F) W.B. 24°C (75°F)
Heating Indoor : D.B. 20°C (68°F) Outdoor : D.B. 7°C (45°F) W.B. 6°C (43°F)
Refrigerant piping length (one way) : 5m (16ft.)

2. Guaranteed operating range

		Indoor	Outdoor
Cooling	Upper limit	D.B. 35°C, W.B. 22.5°C	D.B. 46°C
	Lower limit	D.B. 19°C, W.B. 15°C	D.B. -5°C ※
Heating	Upper limit	D.B. 28°C	D.B. 21°C, W.B. 15°C
	Lower limit	D.B. 17°C	D.B. -15°C, W.B. -15°C

3. Guaranteed voltage

Indoor unit 198-264V, 50Hz

Outdoor unit 342-457V, 50Hz

4. Above data are based on the indicated voltage.

Indoor unit Single phase 230V 50Hz

Outdoor unit 3 phase 400V 50Hz

※ If optional air protect guide installed. D.B. -15°C

Unit : mm

INDOOR UNIT
PLA-RP50BA
PLA-RP100BA
PLA-RP71BA2

PLA-RP60BA
PLA-RP125BA
PLA-RP100BA3

PLA-RP71BA
PLA-RP125BA2

PLA-RP140BA2

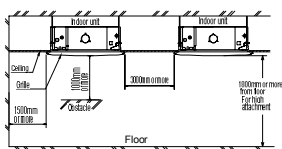
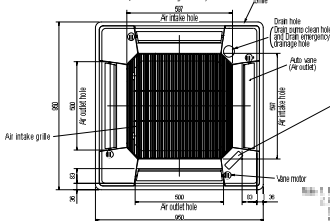
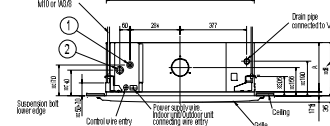
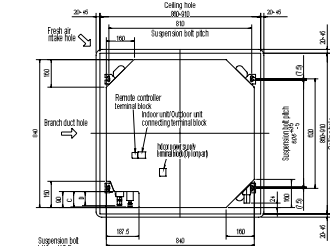

Detail connecting of branch duct (Both aspect)

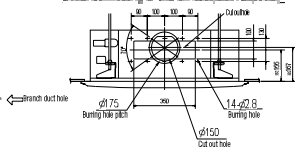

Detail clearing of fresh air intake hole

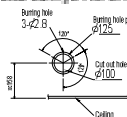

Connected the attached socket.
 Keep approximately 25 to 30mm space between unit ceiling and ceiling side.

Refrigerant Piping: PLA-RP, P1P2, P3P4, P5P6, P7P8



Emergency operation switch Cooling and Heating

Emergency operation switch Heating and Cooling

Emergency operation switch Heating and Cooling

Emergency operation switch Heating and Cooling

Emergency operation switch Heating and Cooling

Emergency operation switch Heating and Cooling

Emergency operation switch Heating and Cooling

Emergency operation switch Heating and Cooling

Emergency operation switch Heating and Cooling

Emergency operation switch Heating and Cooling

Emergency operation switch Heating and Cooling

Emergency operation switch Heating and Cooling

Emergency operation switch Heating and Cooling

Emergency operation switch Heating and Cooling

Emergency operation switch Heating and Cooling

Emergency operation switch Heating and Cooling

Emergency operation switch Heating and Cooling

Emergency operation switch Heating and Cooling

Emergency operation switch Heating and Cooling

Emergency operation switch Heating and Cooling

Emergency operation switch Heating and Cooling

Emergency operation switch Heating and Cooling

Emergency operation switch Heating and Cooling

Emergency operation switch Heating and Cooling

Emergency operation switch Heating and Cooling

Emergency operation switch Heating and Cooling

Emergency operation switch Heating and Cooling

Emergency operation switch Heating and Cooling

Emergency operation switch Heating and Cooling

Emergency operation switch Heating and Cooling

Emergency operation switch Heating and Cooling

Emergency operation switch Heating and Cooling

Emergency operation switch Heating and Cooling

Emergency operation switch Heating and Cooling

Emergency operation switch Heating and Cooling

1. Make sure the air intake hole is not blocked.
2. Do not block the air intake hole with any object.
3. Do not block the air intake hole with any object.
4. Do not block the air intake hole with any object.
5. Do not block the air intake hole with any object.
6. Do not block the air intake hole with any object.
7. Do not block the air intake hole with any object.
8. Do not block the air intake hole with any object.
9. Do not block the air intake hole with any object.
10. Do not block the air intake hole with any object.
11. Do not block the air intake hole with any object.
12. Do not block the air intake hole with any object.
13. Do not block the air intake hole with any object.
14. Do not block the air intake hole with any object.
15. Do not block the air intake hole with any object.
16. Do not block the air intake hole with any object.
17. Do not block the air intake hole with any object.
18. Do not block the air intake hole with any object.
19. Do not block the air intake hole with any object.
20. Do not block the air intake hole with any object.

Models	A	B	C	D	E
PLA-RP50BA			80		
PLA-RP60BA	241	258	87	74	400
PLA-RP71BA					
PLA-RP71BA2					
PLA-RP100 125BA					
PLA-RP100BA3					
PLA-RP125 140BA2	281	298	85	77	440

PEA-RP200GA

Unit : mm

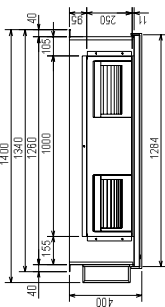
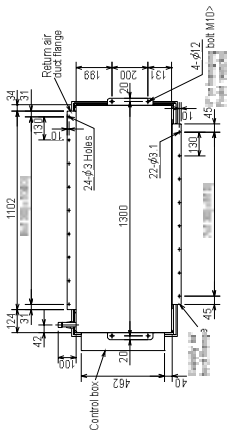

RECOMENDACIÓN:
 Para cubrir el exterior del equipo, se recomienda utilizar un protector de lluvia y un protector de viento.
 Para obtener más información, consulte el manual de usuario.

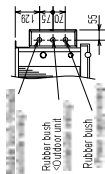

A

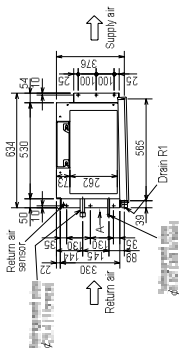

PCA-RP60KA
PCA-RP71KA

Unit : mm

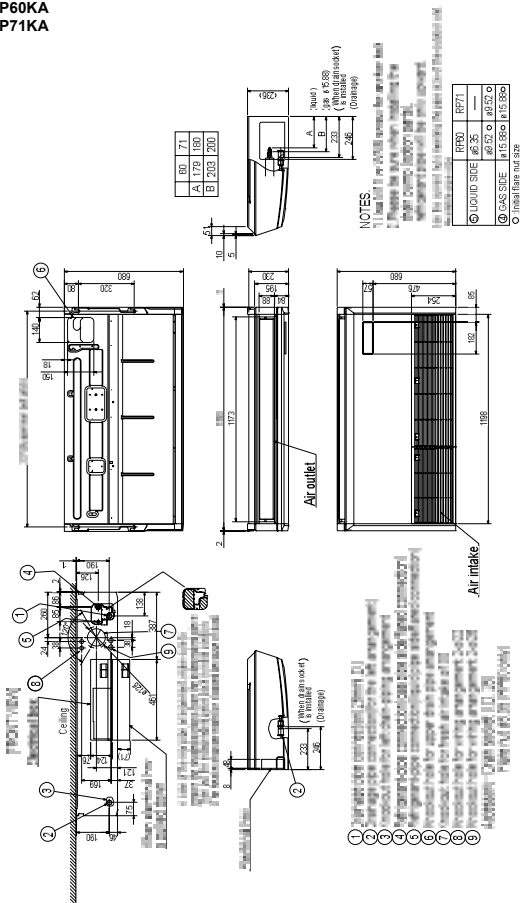

PCA-RP100KA
PCA-RP125KA
PCA-RP140KA

Unit : mm

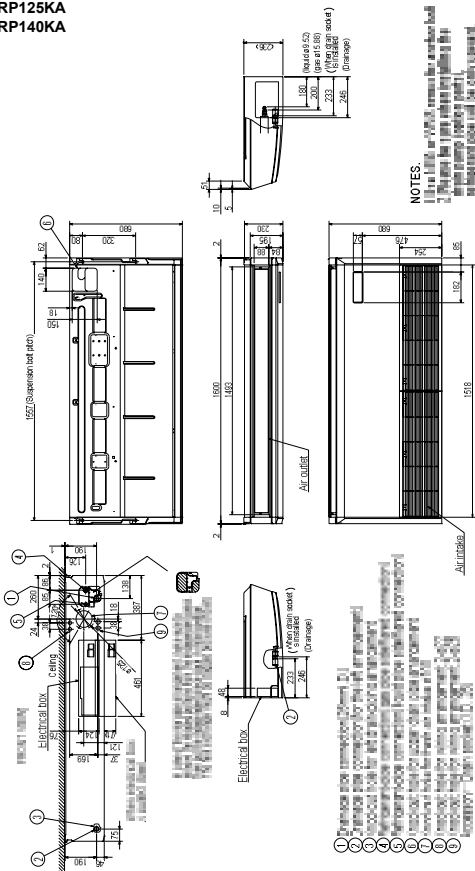

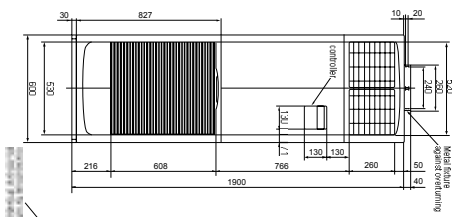
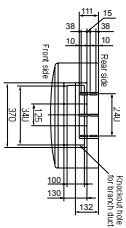

Knock-out hole for branch duct



Knock-out hole for wiring Ø17

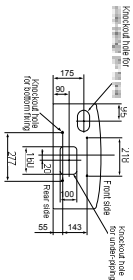

Knock-out hole for bottom ring

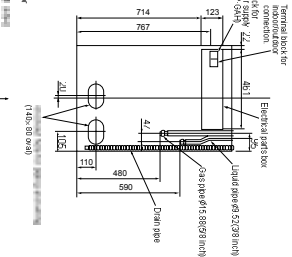

Terminal block for induction/air connection

Terminal block for heating/cooling (only FSH-P 9AH)

Electrical parts box

Liquid pipe ø3 (53/38 inch)

Gas pipe ø15 (88/78 inch)

Drain pipe

Knock-out hole for wiring Ø17

Knock-out hole for branch duct

Knock-out hole for wiring Ø17

Knock-out hole for branch duct

Knock-out hole for wiring Ø17

Knock-out hole for branch duct

Knock-out hole for wiring Ø17

Knock-out hole for branch duct

Knock-out hole for wiring Ø17

Knock-out hole for branch duct

Knock-out hole for wiring Ø17

Knock-out hole for branch duct

Knock-out hole for wiring Ø17

Knock-out hole for branch duct

Knock-out hole for wiring Ø17

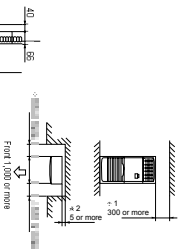

Front 1000 or more

A-2 Adjustable

PSA-RP71GA

Unit : mm

PSA-RP100GA
PSA-RP125GA
PSA-RP140GA

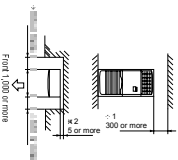
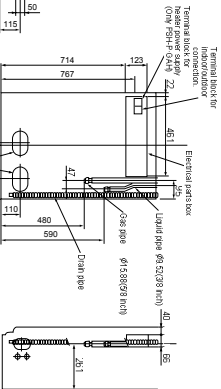
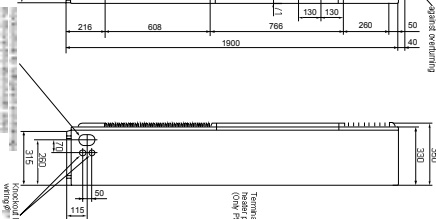
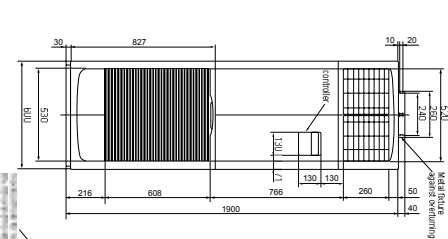
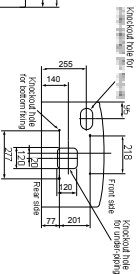
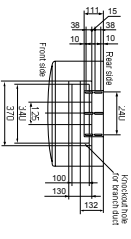

*1
*2 Adjustable

A

Unit : mm

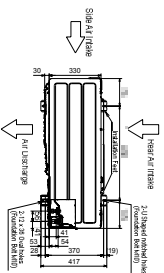
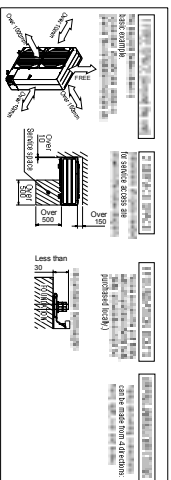

Example of Notes

- ① Dimensions of standard model are shown in this example.
- ② Dimensions of special model are shown in this example.
- ③ Dimensions of special model are shown in this example.

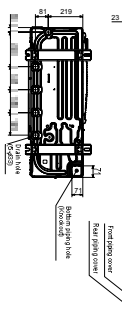
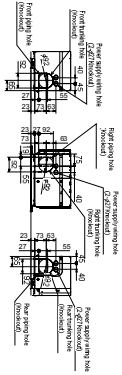
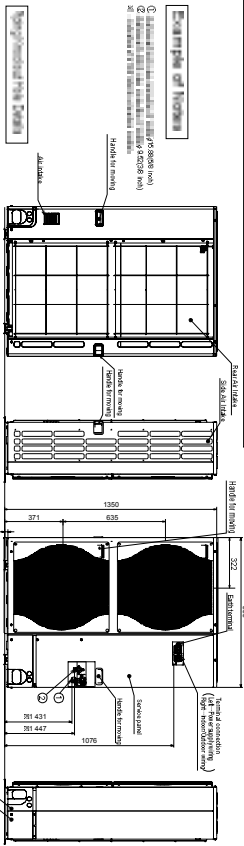

Unit : mm

WIRED REMOTE CONTROLLER

Unit : mm

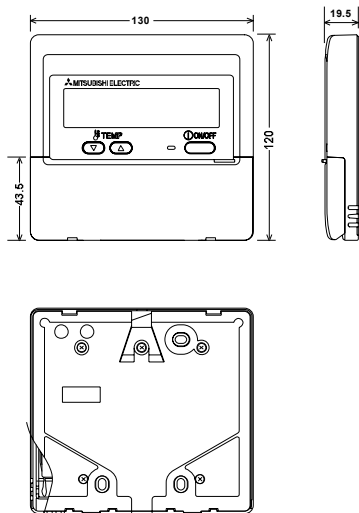

WIRELESS REMOTE CONTROLLER

Unit : mm

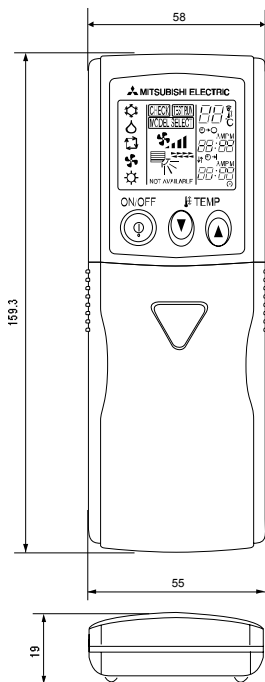

4-1. INDOOR UNIT

PLA-RP50BA
PLA-RP71BA2

PLA-RP60BA
PLA-RP100BA3

PLA-RP71BA
PLA-RP125BA2

PLA-RP100BA
PLA-RP140BA2

PLA-RP125BA

LEGEND

SYMBOL	NAME	SYMBOL	NAME
IB	INDOOR CONTROLLER BOARD	TB2	TERMINAL BLOCK (Indoor unit Power (option))
CN1L	CONNECTOR (LDS/NA1)	TB4	TERMINAL BLOCK (INDOOR/OUTDOOR CONNECTING LINE)
CN2	CONNECTOR (REMOTE SWITCH)	TB5, TB6	TERMINAL BLOCK (REMOTE CONTROLLER'S TRANSMISSION LINE)
CN1T	CONNECTOR (TBA TERMINAL-A)	TH1	ROOM TEMP THERMISTOR (10° / 15.0 25° / 5.4VQ/DETECT)
CN1S	CONNECTOR (CENTRALLY CONTROL)	TH2	PIPE TEMP THERMISTOR (LQ/15.0 25° / 5.4VQ/DETECT)
LED1	POWER SUPPLY (L)	THS	COND. / EVA. TEMP THERMISTOR (10° / 15.0 25° / 5.4VQ/DETECT)
LED2	POWER SUPPLY (R)		
LED3	TRANSMISSION (INDOOR/OUTDOOR)		
SW1	SWITCH (MODE SELECTION) (Refer table 1)		
SW2	SWITCH (CAPACITY CODE) (Refer table 2)		
CN1	CONNECTOR (EMERGENCY OPERATION)	OPTION PART	
X1	RELAY (DRAIN PUMP)	WB	PCB FOR WIRELESS REMOTE CONTROLLER
DCL	REFRACOR	BZ	BUZZER
UP	DRAIN-UP MACHINE	LED1	LED (OPERATION INDICATION (GREEN))
FS	DRAIN FLOAT SWITCH	LED2	LED (PREPARATION FOR HEATING (ORANGE))
MF	FAN MOTOR	RU	RECEIVING UNIT
MV	VALE MOTOR	SW1	EMERGENCY OPERATION (HEAT / DOWN)
		SW2	EMERGENCY OPERATION (COOL / UP)

<Table 1> SW1 (MODEL SELECTION)

MODELS	SW1 SETTING
PLA-RP50BA	
PLA-RP7125BA2	
PLA-RP100BA2	
PLA-RP100BA3	

<Table 2> SW2 (CAPACITY CODE)

CAPX (V)	SETTING	CAPX (V)	SETTING
50		100	
60		125	
71		140	

The black square ■ indicates a switch position.

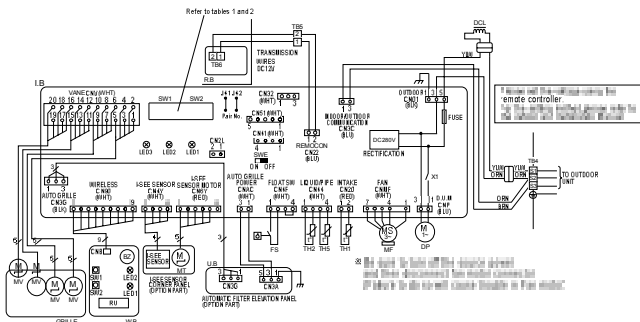

Notes

1. The indoor unit is using copper wire for power supply.
2. The indoor unit is using aluminum wire for power supply.
3. The indoor unit is using copper wire for power supply.
4. The indoor unit is using aluminum wire for power supply.
5. The indoor unit is using copper wire for power supply.
6. The indoor unit is using aluminum wire for power supply.
7. The indoor unit is using copper wire for power supply.
8. The indoor unit is using aluminum wire for power supply.
9. The indoor unit is using copper wire for power supply.
10. The indoor unit is using aluminum wire for power supply.

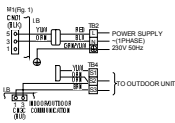

PEAD-RP50JA(L) PEAD-RP60JA(L) PEAD-RP71JA(L)
 PEAD-RP100JA(L) PEAD-RP125JA(L) PEAD-RP140JA(L)

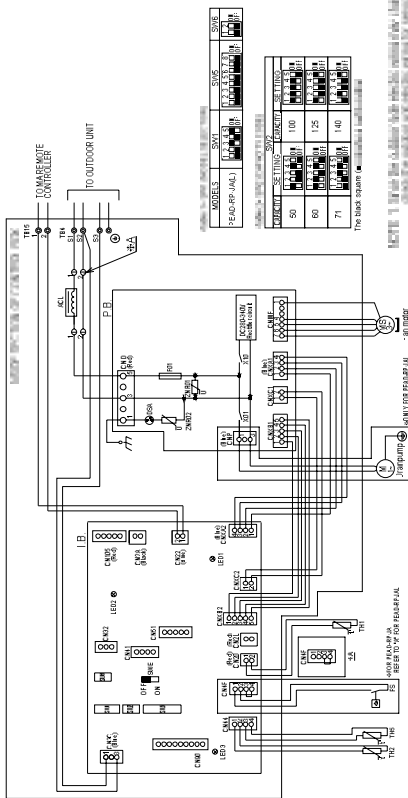

MODELS

PEAD-RP-JA(L)	SW1	SW5	SW6
50	[Diagram]	[Diagram]	[Diagram]
60	[Diagram]	[Diagram]	[Diagram]
71	[Diagram]	[Diagram]	[Diagram]

CONNECTOR SETTINGS

CONNECTOR	SETTING	CONNECTOR	SETTING
50	[Diagram]	100	[Diagram]
60	[Diagram]	125	[Diagram]
71	[Diagram]	140	[Diagram]

The black square ■ indicates a terminal with a lock.

- NOTE 1 Turn the outdoor unit power switch to the "ON" position. Then, the outdoor unit will start to operate. The outdoor unit will stop operating when the power is cut off.
- 2 Outdoor unit outdoor control system does not work for connecting.
- 3 Connect the outdoor unit to the indoor unit. Refer to the manual for the indoor unit.



SYMBOL	NAME	SYMBOL	NAME	SYMBOL	NAME
IB	...	TH1	...	TH1	...
CMA2	...	TH2	...	TH2	...
CMA3	...	TH5	...	TH5	...
CMA4	...	ACL	...	ACL	...
CMA5	...	FS	...	FS	...
CMA6	...	TB4	...	TB4	...
CMA7	...	TB15	...	TB15	...
RELE1
RELE2
RELE3
RELE4
RELE5

PEA-RP200, 250GA

INDOOR UNIT SYMBOL	NAME
MF1	MOTOR COMPRESSOR
51F	5 AMP FUSE
49F	4 AMP FUSE
TB2.4.5	TERMINAL BLOCK
TH1	ROOM TEMP THERMISTOR
TH2	LIQUID PIPE TEMP THERMISTOR
TH5	COND/EA TEMP THERMISTOR
X1	AUXILIARY RELAY
CH1.2	SURGE KILLER
F1	FUSE (6.3AL/250V)
ZNR	VARIABLE RESISTOR
SW1	SWITCH
SW2	SWITCH
SW3	SWITCH
SW4	SWITCH
SW5	SWITCH
SW6	SWITCH
SW7	SWITCH
SW8	SWITCH
SW9	SWITCH
SW10	SWITCH
SW11	SWITCH
SW12	SWITCH
SW13	SWITCH
SW14	SWITCH
SW15	SWITCH
SW16	SWITCH
SW17	SWITCH
SW18	SWITCH
SW19	SWITCH
SW20	SWITCH
SW21	SWITCH
SW22	SWITCH
SW23	SWITCH
SW24	SWITCH
SW25	SWITCH
SW26	SWITCH
SW27	SWITCH
SW28	SWITCH
SW29	SWITCH
SW30	SWITCH
SW31	SWITCH
SW32	SWITCH
SW33	SWITCH
SW34	SWITCH
SW35	SWITCH
SW36	SWITCH
SW37	SWITCH
SW38	SWITCH
SW39	SWITCH
SW40	SWITCH
SW41	SWITCH
SW42	SWITCH
SW43	SWITCH
SW44	SWITCH
SW45	SWITCH
SW46	SWITCH
SW47	SWITCH
SW48	SWITCH
SW49	SWITCH
SW50	SWITCH
SW51	SWITCH
SW52	SWITCH
SW53	SWITCH
SW54	SWITCH
SW55	SWITCH
SW56	SWITCH
SW57	SWITCH
SW58	SWITCH
SW59	SWITCH
SW60	SWITCH
SW61	SWITCH
SW62	SWITCH
SW63	SWITCH
SW64	SWITCH
SW65	SWITCH
SW66	SWITCH
SW67	SWITCH
SW68	SWITCH
SW69	SWITCH
SW70	SWITCH
SW71	SWITCH
SW72	SWITCH
SW73	SWITCH
SW74	SWITCH
SW75	SWITCH
SW76	SWITCH
SW77	SWITCH
SW78	SWITCH
SW79	SWITCH
SW80	SWITCH
SW81	SWITCH
SW82	SWITCH
SW83	SWITCH
SW84	SWITCH
SW85	SWITCH
SW86	SWITCH
SW87	SWITCH
SW88	SWITCH
SW89	SWITCH
SW90	SWITCH
SW91	SWITCH
SW92	SWITCH
SW93	SWITCH
SW94	SWITCH
SW95	SWITCH
SW96	SWITCH
SW97	SWITCH
SW98	SWITCH
SW99	SWITCH
SW100	SWITCH

INDOOR UNIT SYMBOL	NAME
TB6	TERMINAL BLOCK

Caution:
 1. Do not touch the terminals of the indoor unit with bare hands. The terminals are hot when the unit is operating.
 2. Do not touch the terminals of the indoor unit when the unit is operating.
 3. Do not touch the terminals of the indoor unit when the unit is operating.
 4. Do not touch the terminals of the indoor unit when the unit is operating.
 5. Do not touch the terminals of the indoor unit when the unit is operating.
 6. Do not touch the terminals of the indoor unit when the unit is operating.
 7. Do not touch the terminals of the indoor unit when the unit is operating.
 8. Do not touch the terminals of the indoor unit when the unit is operating.
 9. Do not touch the terminals of the indoor unit when the unit is operating.
 10. Do not touch the terminals of the indoor unit when the unit is operating.

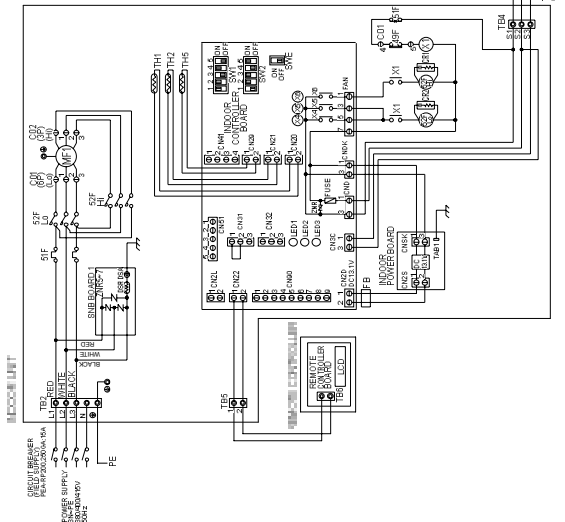

PKA-RP50HAL

[Explanation of symbols]

Symbol	Name	Symbol	Name
IB	Indoor controller board	M	Yarn motor
CN2L	Connector (LOSSNAY)	MS	Fan motor
CN32	Connector (Remote switch)	S.W	Switch board
CN41	Connector (HA terminal-A)	SWE2	Emergency operation
CN51	Connector (Centrally control)	TB2	Terminal block (Indoor unit Power (option))
CN60	Connector (Remote operation adapter)	TB4	Terminal block (Indoor/outdoor connecting line)
FUSE	FUSE(T3 15A/250V)	TB5	Room temp. Thermistor (0°C/19k Ω , 22°C/5.4k Ω) Detect)
LED1	Power supply (L.B)	TH1	Pipe temp. Thermistor/liquid (0°C/19k Ω , 22°C/5.4k Ω) Detect)
LED2	Power supply (R.B)	TH2	Cond./eva. temp. Thermistor (0°C/19k Ω , 22°C/5.4k Ω) Detect)
LED3	Transmission (Indoor-outdoor)	TH5	Pub for wireless remote controller (LED1: Operation indication - Green; LED2: LED (Preparation for heating - Orange); REC.1: Receiving unit)
SW1	Switch (Model selection) ^{*)} See table 1	DCL	REACTOR
SW2	Switch (Capacity code) ^{*)} See table 2	DP	DRAIN PUMP (OPTION)
SWE	Connector (Emergency operation)	FS	DRAIN FLOAT SWITCH (OPTION)
X1	Relay (Drain pump (option))		
CNP	Drain pump (option) power supply (Drain pump (option))		
CN4F	Drain float switch (Drain pump (option))		
R.B	Wired remote controller(option)		
TB6	Terminal block (Remote controller transmission line)		

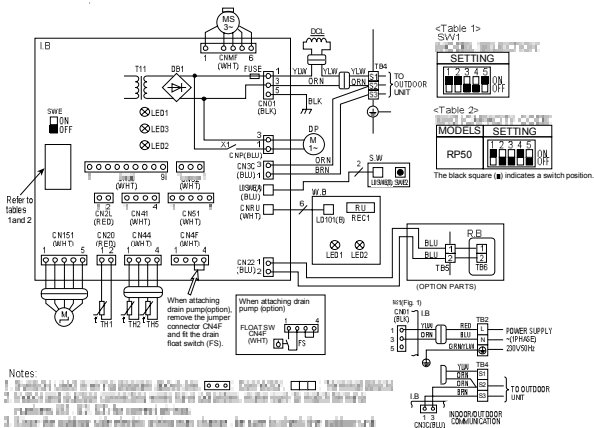

Notes:

1. Switch ON/OFF
 2. Indoor and outdoor communication wires for indoor unit must be matched to the numbers (1, 2, 3, 4, 5) for correct service.
 3. Under the outdoor unit, there are two cases for the case (indoor) for outdoor unit. Please refer to the manual for service.
 4. The indoor unit is the type of indoor and outdoor communication wire (Indoor/Outdoor) (DCL) (Indoor communication wire) for power (option).
- ^{*)} If indoor and outdoor unit have remote control system, refer to Fig. 1.
- ^{*)} For power supply system of TH1 unit, refer to the (S-4-2-2) label (S-4-2) near the board.

PKA-RP60KAL PKA-RP71KAL PKA-RP100KAL

[LEGEND]

SYMBOL	NAME	SYMBOL	NAME
LB	Indoor controller board	M	Vane motor
CN2/L	Connector (LOSSNAY)	MS	Fan motor
CN32	Connector (Remote switch)	S.W	Switch board
CN41	Connector (HA terminal-A)	SWE2	Emergency operation
CN51	Connector (Centrally control)	TB2	Terminal block (Indoor unit Power (option))
CN90	Connector (Remote operation adapter)	TB4	Terminal block (Indoor/outdoor connecting line)
FUSE	FUSE (T3 15A/250V)	TB5	Terminal block (Remote controller transmission line)
LED1	Power supply (LB)	TH1	Room temp. Thermistor (0°C / 15kΩ, 25°C / 5.4kΩ Detect)
LED2	Power supply (RB)	TH2	Pipe temp. Thermistor/liquid (0°C / 15kΩ, 25°C / 5.4kΩ Detect)
LED3	Transmission (Indoor-outdoor)	TH5	Cond. / eva. temp. Thermistor (0°C / 15kΩ, 25°C / 5.4kΩ Detect)
SW1	Switch (Model selection) [See table 1]	WB	Box for wireless remote controller
SW2	Switch (Capacity code) [See table 2]	LED1	LED (Operation indication - Green)
SWE	Connector (Emergency operation)	LED2	LED (Preparation for heating - Orange)
X1	Relay (Drain pump(option))	REC1	Receiving unit
CNP	Drain pump (option) power supply (Sold separately/Drain pump(option))	DCL	REACTOR
CN4F	Drain pump (option) power supply connector (Sold separately/Drain pump(option))	DP	DRAIN PUMP (OPTION)
R.B	Wired remote controller (option)	FS	DRAIN FLOAT SWITCH (OPTION)
TB6	Terminal block (Indoor/outdoor connecting line)		

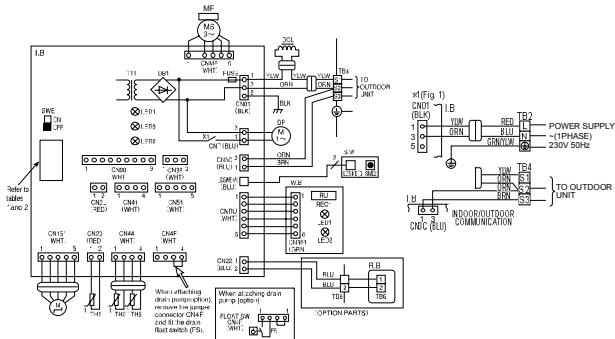

(Table 1)

MODEL SELECTION
SW1
SETTING

(Table 2)

MODEL SELECTION	MODEL SELECTION	MODEL SELECTION
PKA-RP60KAL	PKA-RP71KAL	PKA-RP100KAL
SETTING	SETTING	SETTING

The black square (■) indicates a switch position.

Notes:

1. Symbols used in wiring diagrams are as follows: Connector, Terminal block.
2. Indoor and outdoor connecting wires have a plastic insulating sheath to match terminal numbers (R1, R2, R3) for correct wiring.
3. Since the indoor and outdoor wiring may change, it is necessary to check the outdoor unit electric wiring diagram for servicing.
4. This diagram shows the wiring of indoor and outdoor connecting wires (specification of 200V) signaling supported by them for power and signal.
 - ※ If indoor and outdoor units have separate power supplies, refer to Fig. 1.
 - ※ For power supply system of this set, refer to the cable label located near this diagram.

PCA-RP50KA PCA-RP60KA PCA-RP71KA
PCA-RP100KA PCA-RP125KA PCA-RP140KA

[LEGEND]

SYMBOL	NAME	SYMBOL	NAME
IB	INDOOR CONTROLLER BOARD	TBA	TERMINAL BLOCK (INDOOR/OUTDOOR CONNECTING LINE)
CNA	CONNECTOR (LOSSNAY)	TBB	TERMINAL BLOCK (REMOTE CONTROLLER)
CN2	CONNECTOR (REMOTE SWITCH)	TL	TRANSMISSION LINE
CN4	CONNECTOR (TERMINAL A)	TR	ROOM TEMP. THERMISTOR
CN5	CONNECTOR (GENERAL CONTROL)	TR1	PIPE TEMP. THERMISTOR (4°C / 19.0 / 25°C / 5.4 / 40°C DETECT)
FUSE	FUSE (R3 3AL 250V)	TR2	COND./FEA. TEMP. THERMISTOR (4°C / 19.0 / 25°C / 5.4 / 40°C DETECT)
LE2F	POWER SUPPLY (FB)	TR3	COND./FEA. TEMP. THERMISTOR (4°C / 19.0 / 25°C / 5.4 / 40°C DETECT)
LE2	POWER SUPPLY (RB)	TR4	COND./FEA. TEMP. THERMISTOR (4°C / 19.0 / 25°C / 5.4 / 40°C DETECT)
LE3	TRANSMISSION (INDOOR-OUTDOOR)	TR5	COND./FEA. TEMP. THERMISTOR (4°C / 19.0 / 25°C / 5.4 / 40°C DETECT)
SW1	SWITCH (MODE SELECTION) (See table 1)	FAN (P/R)	FAN MOTOR
SW2	SWITCH (CAPACITY CODE) (See table 2)	IRCS	PCB FOR WIRELESS REMOTE CONTROLLER
SW3	CONNECTOR (EMERGENCY OPERATION)	BZ	BUZZER
AT	ASRAY (ASRAY PUMP)	LED1	LED (OPERATION INDICATION - GREEN)
CRS	WIRELESS REMOTE CONTROLLER BOARD	LED2	LED (PREPARATION FOR HEATING - ORANGE)
DRL	REACTOR	RSU	RECEIVING UNIT
MF	FAN MOTOR	SWT	EMERGENCY OPERATION (HEAT / DOWN)
MY	WAVE MOTOR	SW2	EMERGENCY OPERATION (COOL / UP)
TB2	TERMINAL BLOCK (INDOOR-OUTDOOR CONNECTING LINE)	CP	DRAIN PUMP
		FS	DRAIN FLOAT SWITCH

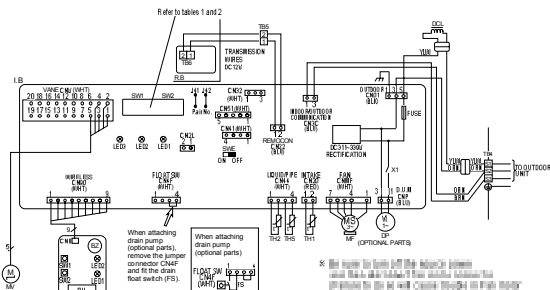

<Table 1> SW1
(MODEL SELECTION)

SW1	
Service	
1	2
3	4
5	6
7	8
9	10

<Table 2> SW2 (CAPACITY CODE)

MODELS	SW2	
	Service	MODELS
PCA-RP50A	1 2 3 4 5 0 0 0 0 0	PCA-RP100A 1 2 3 4 5 0 0 0 0 0
PCA-RP60A	1 2 3 4 5 0 0 0 0 0	PCA-RP125A 1 2 3 4 5 0 0 0 0 0
PCA-RP71A	1 2 3 4 5 0 0 0 0 0	PCA-RP140A 1 2 3 4 5 0 0 0 0 0

The black square (■) indicates a switch position.

Notes: 1. Symbols used in wiring diagram above are, (○●○): Connector, (□□□□): Terminal (block).

- Indoor and outdoor connecting wires are made with polarities, make wiring matching terminal numbers (S1, S2, S3).
- Since the outdoor side electric wiring may change, be sure to check the outdoor unit electric wiring for servicing.
- This diagram shows the wiring of indoor and outdoor connecting wires (specification of 230V), adopting superimposed system for power and signal.

※1: If indoor and outdoor units have separate power supplies, refer to Fig. 1.

※2: For power supply system of this unit, refer to the caution label located near this diagram.

PCA-RP71HA PCA-RP125HA

[LEGEND]

SYMBOL			NAME
P.B	INDOOR POWER BOARD	MF1, MF2	FAN MOTOR
I.B	INDOOR CONTROLLER BOARD	C1, C2	CAPACITOR(FAN MOTOR)
FUSE	FUSE (T6.3AL250V)	H2	DEW PREVENTION HEATER
ZNR	VARIATOR	TB2	TERMINAL BLOCK(INDOOR UNIT POWER(OPTION))
CN2L	CONNECTOR (LOSSNAY)	TB4	TERMINAL BLOCK(INDOOR/OUTDOOR CONNECTING LINE)
CN32	CONNECTOR (REMOTE SWITCH)	TB5, TB6	TERMINAL BLOCK(REMOTE CONTROLLER TRANSMISSION LINE)
CN41	CONNECTOR (HA TERMINAL-A)		
CN51	CONNECTOR (INDOOR-OUTDOOR)		
LED1	POWER SUPPLY (L.B)		
LED2	POWER SUPPLY (R.B)		
LED3	TRANSMISSION(INDOOR-OUTDOOR)	TH1	ROOM TEMP.THERMISTOR (0°C/15kΩ, 25°C/5.4kΩ DETECT)
X1	RELAY (DEW PREVENTION HEATER)	TH2	PIPE TEMP.THERMISTOR/LIQUID (0°C/15kΩ, 25°C/5.4kΩ DETECT)
X4	RELAY(FAN MOTOR)	TH5	COND./EVA.TEMP.THERMISTOR (0°C/15kΩ, 25°C/5.4kΩ DETECT)
X5	RELAY(FAN MOTOR)		
X6	RELAY(FAN MOTOR)		
SW1	SWITCH (POWER SUPPLY)	R.B	WIRED REMOTE CONTROLLER BOARD
SW2	SWITCH (REMOTE CONTROL)		
SWE	SWITCH (EMERGENCY OPERATION)		

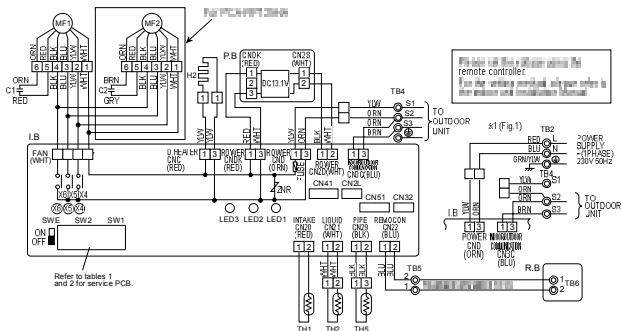

Table 1

SW1	Service board
1	ON
2	ON
3	ON
4	ON
5	OFF

Table 2

MODELS	Service board	MODELS	Service board
PCA-RP71HA	1 2 3 4 5 ON OFF	PCA-RP125HA	1 2 3 4 5 ON OFF

The black square ■ indicates a switch position.

Notes:

- Symbols used in wiring diagram above are, □: Connector, ⊙: Terminal (block).
 - Indoor and outdoor connecting wires have polarities, make sure to match terminal numbers (S1, S2, S3) for correct wirings.
 - Since the outdoor side electric wiring may change, be sure to check the outdoor unit electric wiring diagram for servicing.
 - This diagram shows the wiring of indoor and outdoor connecting wires (specification of 230V), adopting superimposed system for power and signal.
- ※1: If indoor and outdoor units have separate power supplies, refer to Fig. 1.
 ※2: For power supply system of this unit, refer to the caution label located near this diagram.

PSA-RP71GA PSA-RP100GA PSA-RP125GA PSA-RP140GA

LEGEND

SYMBOL	Meaning	SYMBOL	Meaning	SYMBOL	Meaning
PB	POWER BOARD	B SW1	POWER SWITCH (ON/OFF)	F	FAN MOTOR
LB	LOWER BOARD	B SW2	POWER SWITCH (ON/OFF)	MF	FAN MOTOR
ZNR	VARIABLE RESISTOR	X2	RELAY (LOUVER)	ML	LOUVER MOTOR
LED3	LED	TH	TEMPERATURE SENSOR	TB2	TERMINAL BLOCK
LED2	LED	TB6	TERMINAL BLOCK	TH1	TEMPERATURE SENSOR (0°C/15KΩ, 25°C/5.4KΩ DETECT)
LED1	LED	HEATER	HEATER	TH2	TEMPERATURE SENSOR (0°C/15KΩ, 25°C/5.4KΩ DETECT)
FS1,2	FUSE	FS1,2	FUSE	TH5	TEMPERATURE SENSOR (0°C/15KΩ, 25°C/5.4KΩ DETECT)
H	HEATER	H	HEATER		
26H	HEATER	26H	HEATER		
88H	HEATER	88H	HEATER		

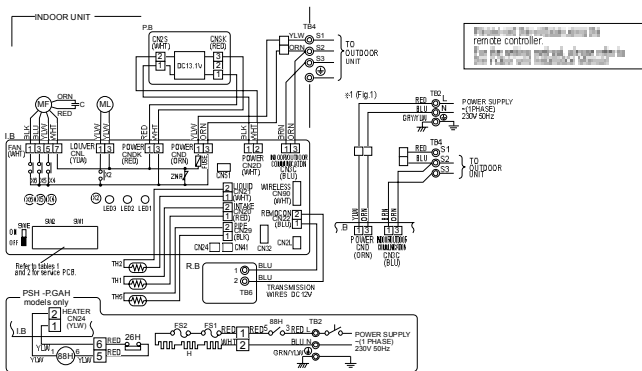

Table 1

MODELS	SW2 Service board															
PSA-RP-GA PSH-P-GAH	<table border="1"> <tr> <td>1</td><td>2</td><td>3</td><td>4</td><td>5</td> </tr> <tr> <td>ON</td><td>ON</td><td>ON</td><td>ON</td><td>ON</td> </tr> <tr> <td>OFF</td><td>OFF</td><td>OFF</td><td>OFF</td><td>OFF</td> </tr> </table>	1	2	3	4	5	ON	ON	ON	ON	ON	OFF	OFF	OFF	OFF	OFF
1	2	3	4	5												
ON	ON	ON	ON	ON												
OFF	OFF	OFF	OFF	OFF												

- Notes:
1. Symbols used in wiring diagram above are, : Connector, : Terminal (block).
 2. Indoor and outdoor connecting wires have polarities, make sure to match terminal numbers (S1, S2, S3) for correct wirings.
 3. Since the outdoor side electric wiring may change, be sure to check the outdoor unit electric wiring diagram for servicing.
 4. This diagram shows the wiring of indoor and outdoor connecting wires (specification of 230V), adopting superimposed system for power and signal.
- ※1: If indoor and outdoor units have separate power supplies, refer to Fig. 1.
 ※2: For power supply system of this unit, refer to the caution label located near this diagram.

Table 2

MODELS	SW2 Service board															
PSA-RP71GA PSH-P71GAH	<table border="1"> <tr> <td>1</td><td>2</td><td>3</td><td>4</td><td>5</td> </tr> <tr> <td>ON</td><td>ON</td><td>ON</td><td>ON</td><td>ON</td> </tr> <tr> <td>OFF</td><td>OFF</td><td>OFF</td><td>OFF</td><td>OFF</td> </tr> </table>	1	2	3	4	5	ON	ON	ON	ON	ON	OFF	OFF	OFF	OFF	OFF
1	2	3	4	5												
ON	ON	ON	ON	ON												
OFF	OFF	OFF	OFF	OFF												
PSA-RP100GA PSH-P100GAH	<table border="1"> <tr> <td>1</td><td>2</td><td>3</td><td>4</td><td>5</td> </tr> <tr> <td>ON</td><td>ON</td><td>ON</td><td>ON</td><td>ON</td> </tr> <tr> <td>OFF</td><td>OFF</td><td>OFF</td><td>OFF</td><td>OFF</td> </tr> </table>	1	2	3	4	5	ON	ON	ON	ON	ON	OFF	OFF	OFF	OFF	OFF
1	2	3	4	5												
ON	ON	ON	ON	ON												
OFF	OFF	OFF	OFF	OFF												
PSA-RP125GA PSH-P125GAH	<table border="1"> <tr> <td>1</td><td>2</td><td>3</td><td>4</td><td>5</td> </tr> <tr> <td>ON</td><td>ON</td><td>ON</td><td>ON</td><td>ON</td> </tr> <tr> <td>OFF</td><td>OFF</td><td>OFF</td><td>OFF</td><td>OFF</td> </tr> </table>	1	2	3	4	5	ON	ON	ON	ON	ON	OFF	OFF	OFF	OFF	OFF
1	2	3	4	5												
ON	ON	ON	ON	ON												
OFF	OFF	OFF	OFF	OFF												
PSA-RP140GA PSH-P140GAH	<table border="1"> <tr> <td>1</td><td>2</td><td>3</td><td>4</td><td>5</td> </tr> <tr> <td>ON</td><td>ON</td><td>ON</td><td>ON</td><td>ON</td> </tr> <tr> <td>OFF</td><td>OFF</td><td>OFF</td><td>OFF</td><td>OFF</td> </tr> </table>	1	2	3	4	5	ON	ON	ON	ON	ON	OFF	OFF	OFF	OFF	OFF
1	2	3	4	5												
ON	ON	ON	ON	ON												
OFF	OFF	OFF	OFF	OFF												

The black square (■) indicates a switch position.

4-2. OUTDOOR UNIT

PUHZ-P100VHA3 PUHZ-P125VHA3 PUHZ-P140VHA3

SYMBOL	NAME	SYMBOL	NAME	SYMBOL	NAME
TB1	Terminal Block (Power Supply, Indoor/Outdoor)	P.B.	Power Circuit Board	SWP	Switch (Function Switch)
MC	Motor for Compressor	U/V/W	Connector Terminal (U/V/W Phase)	SWP	Switch (Pump Down)
MF1, MF2	Fan Motor	L1	Connection Terminal (L-Phase)	CN31	Connector (Emergency Operation)
21S4	Solenoid Valve (Four-Way Valve)	N1	Connection Terminal (N-Phase)	SS	Connector (Connection for Option)
SV	Solenoid Valve (Bypass Valve)	DC11, DC12	Connection Terminal (Reactor)	CNDM	Connector (Connection for Option (Carac. Input))
CH1	Crackcase Heater	IGBT	Power Module	CNM	Connector (A Control Service Inspection Kit)
PSH	High Pressure Switch	E3, E2, E3, E4	Connection Terminal (Ground)	LED1, LED2	LED (Operation Inspection Indicators)
TH3	Thermistor (Outdoor Pipe)	C.B.	Controller Circuit Board	F1, F2, F3, F4	Fuse (T6.3AL250V)
TH6	Thermistor (Outdoor 2-Phase Pipe)	SW*	Switch (Manual Defrost, Defect History Record Reset, Refrigerant Address)	RS, RS2, RS3	Relay
TH7	Thermistor (Ambient)	SW4	Switch (Test Operation)		
TH32	Thermistor (Comp. Surface)	SW5	Switch (Function Switch, Model Select)		
LEV-A	Electric Expansion Valve (Reactor)	SW6	Switch (Model Select)		
DB	Main Smoothing Capacitor	SW7	Switch (Function Switch)		
CY1, CY2	Capacitor	SW8	Switch (Function Switch)		

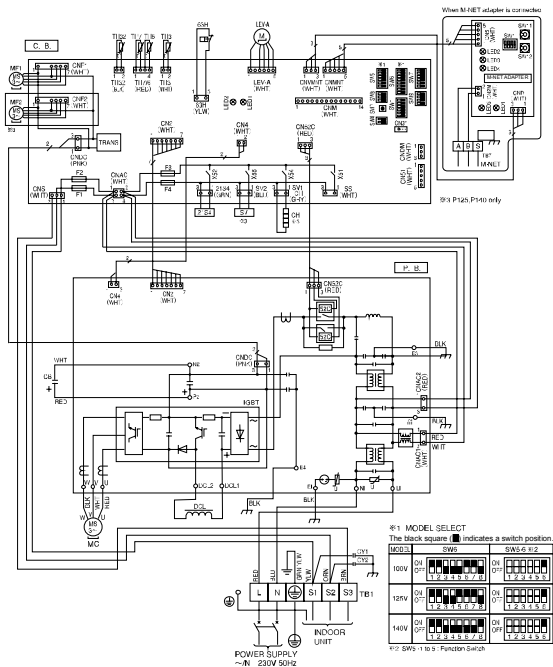

PUHZ-P100YHA

PUHZ-P125YHA

PUHZ-P140YHA

SYMBOL	NAME	SYMBOL	NAME	SYMBOL	NAME
TB1	Terminal Block (Power Supply)	P.C.	Processor	SW25	Switch (Emergency Stop/Reset)
TB2	Terminal Block (Access/Output)	P.CB	Power Circuit Board	SW6	Switch (Motor Select)
MC	Motor for Compressor	TB-U/V/W	Connection Terminal (U/V/W Phase)	SW7	Switch (Function Switch)
MF1, MF2	Fan Motor	TB-L1, 2, 3	Connection Terminal (L1, L2, L3 Phase Supply)	SW8	Switch (Function Switch)
Z154	Solenoid Valve (Flow-Stop Valve)	TB-F1	Connection Terminal	SW9	Switch (Function Switch)
ZV	Solenoid Valve (Bypass Valve)	TB-F2	Connection Terminal	SW3	Switch (Fan Stop)
ZH	Crankcase Heater	TB-G1	Connection Terminal	CH1	Compressor (Emergency Disconnect)
ZS6	High Pressure Switch	TB-N1	Connection Terminal	CS	Compressor (Compressor for option)
TS-3	Thermistor (1-1/2" Pipe)	XSSA	SSD Relay	CRNM	Compressor (Compressor for option)
TS-6	Thermistor (Outdoor 2-Phase Pipe)	N.P.	Main Power (Case) Board	CRNM	Compressor (Compressor for option)
TS-7	Thermistor (Ambient)	LE-L1, R1, B1	Connection Terminal (L1, L2, L3 240V Phase Supply)	CRM	Compressor (A-Control Service Inspection Kit)
TS-32	Thermistor (Coma Surface)	LE-L2, R2, B2	Connection Terminal (L2, L3, L4 240V Phase Supply)	TRD1, LE22	LED (Operation/Inspection Indicators)
LEV-A	Electronic Expansion Valve	GD1, GD2	Connection Terminal (Ground)	TR1, TR2, TR3	LED (Service Indicators)
ACL	Resistor	C.P.	Compressor Control Board	TR4, TR5, TR7	LED (Service Indicators)
DDL	Diode	SW1	Switch (Alarm Off Defrost; Detect Hazard Record Alarm; Refrigerant Adaptive)	TR6, TR8, TR9	LED (Service Indicators)
CE1, CE2	Main Circuit Breaker	SW4	Switch (Alarm Off Defrost; Detect Hazard Record Alarm; Refrigerant Adaptive)	TR10, TR11	LED (Service Indicators)
RS	Surge Current Protect Resistor	SW4	Switch (Test Operation)	TR12, TR13	LED (Service Indicators)

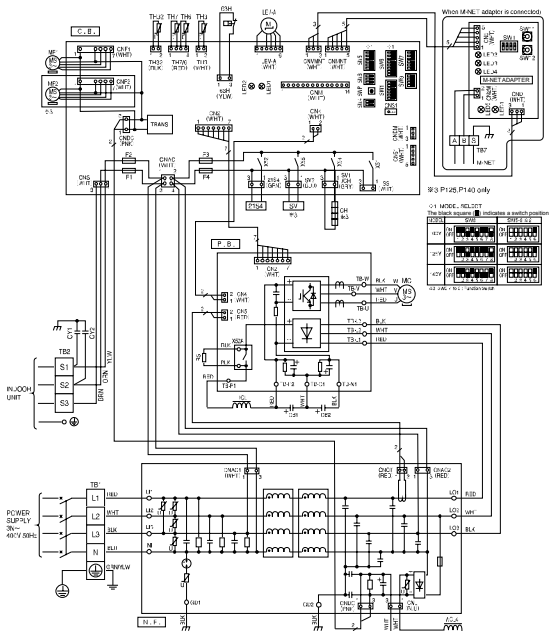

PUHZ-P200YH3 PUHZ-P250YH3

(LEGENDA)

SYMBOL	NAME	SYMBOL	NAME	SYMBOL	NAME
TB1	Terminal Block<Power Supply>	TB1 L1, L2, L3	Terminal Block<Terminal>	SW1P	Switch<Temp. Down>
TB2	Terminal Block<Indoor/Outdoor>	TB-P1	Connection Terminal	CN1	Connector<Transmission>
MC	Motor for Compressor	TB-P2	Connection Terminal	LED1, LED2	LED<Power Supply/DC5V>
MF1, MF2	Fan Motor	TB-C1	Connection Terminal	F3/F4	Fuse<10 A/250V>
P3/P4	Pressure Valve (Four-Way Valve)	TB-NT	Connection Terminal	SS	Switch<Address Setting, 10-bit digit>
S3H	High Pressure Switch	X5DA	5A/2C Relay	CNM1	Connector<M-Net1 communication>
TB3	Thermistor<Discharge>	N1	Main Filter Circuit Board	CNM2T	Connector
TH4	Thermistor<Outdoor 2-Phase Pipe>	N11/CL1	Main Filter Circuit Board	CNM2	Connector
TH5	Thermistor<Outdoor 2-Phase Pipe>	ID1 (ID2) L1	Connection Terminal<VL2/L3 Power Supply>	CNDM	Connector
TH6	Thermistor<Outdoor>	GE1, GE2	Connection Terminal<Discharge>	CNS1	Connector<Transmission>
LV4V	Electronic Expansion Valve	C.B	Control Circuit Board	CNS2	Connector<Transmission>
ACL4	Reactor	SW1	Switch<Status of communication>	CNS3	Connector<Transmission>
DCL	Reactor	SW11	Switch<Address setting, 10-bit digit>	X51, X52	Relay
CB1, CB2	Main Smoothing Capacitor	SW4	Switch<Test Operation>		
RS	High Current PTC Reset Resistor	SW6	Switch<Function Setup>		
FUSE1, FUSE2	Fuse<10A/250V>	SW5	Switch<Address Setting>		
CY1, CY2	Capacitor	SWP	Switch<Function Setup>		
PB	Power Circuit Board	SWB	Switch<Function Setup>		
SCUPWV	Power Supply Unit	SWB	Switch		

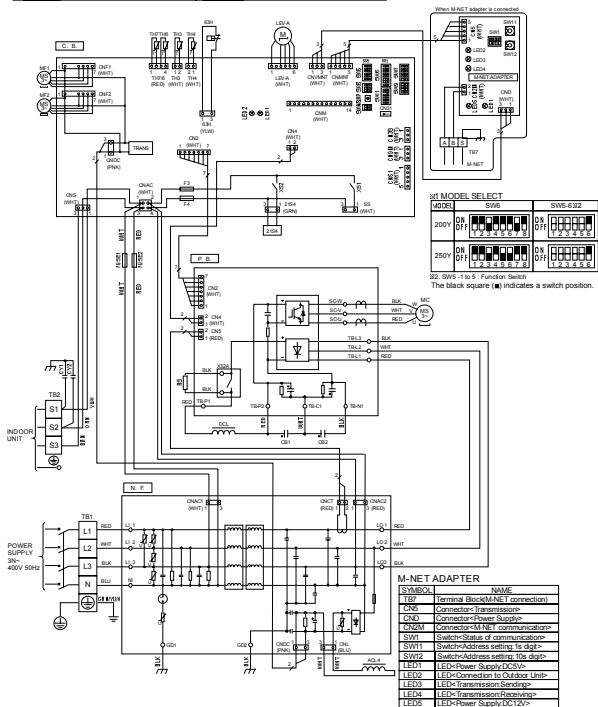

5-1. INDOOR UNIT

PLA-RP-BA/BA2/BA3

PEAD-RP-JA(L)

PCA-RP-KA

PCA-RP-HA

PSA-RP-GA

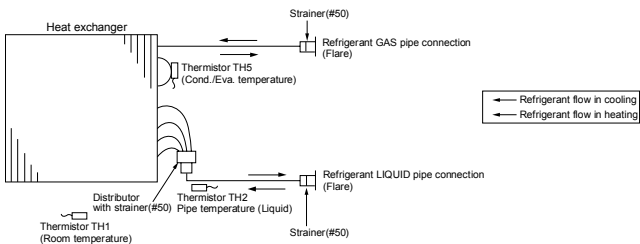

PKA-RP-HAL

PKA-RP-KAL

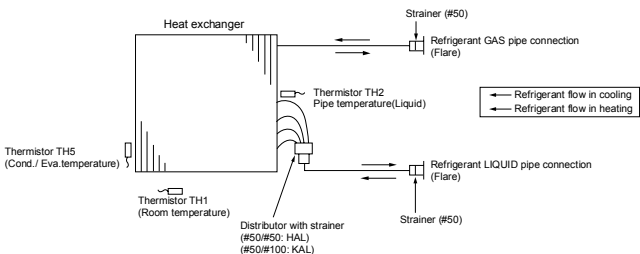

PEA-RP200, 250GA

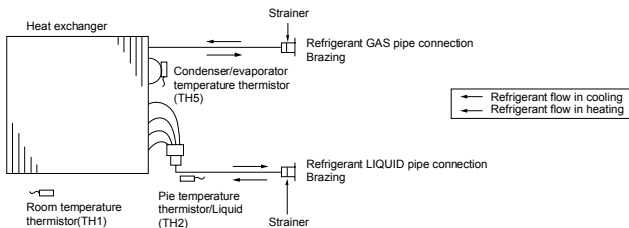

PEA-RP400GA PEA-RP500GA

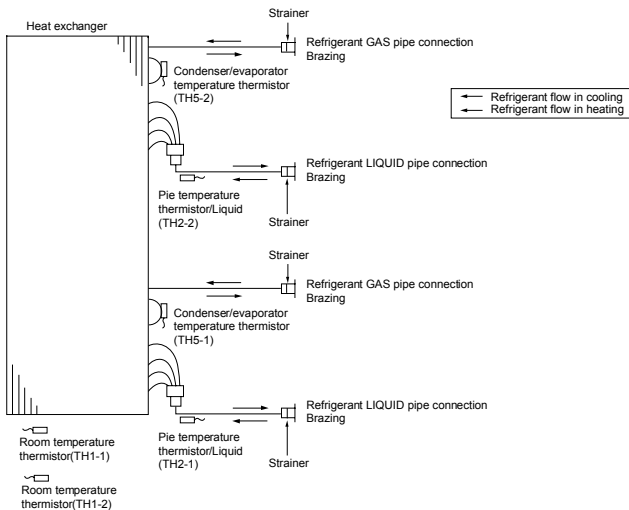

5-2. OUTDOOR UNIT

Unit : mm

PUHZ-P100VHA3
PUHZ-P100YHA

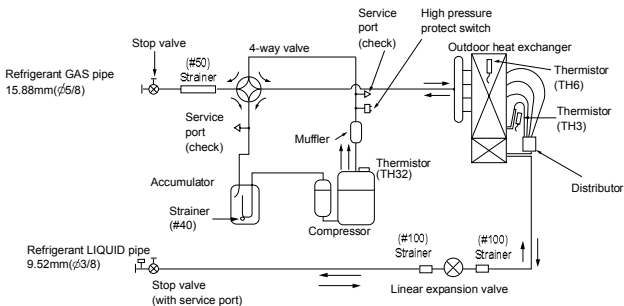
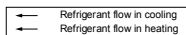

PUHZ-P125VHA3
PUHZ-P125YHA

PUHZ-P140VHA3
PUHZ-P140YHA

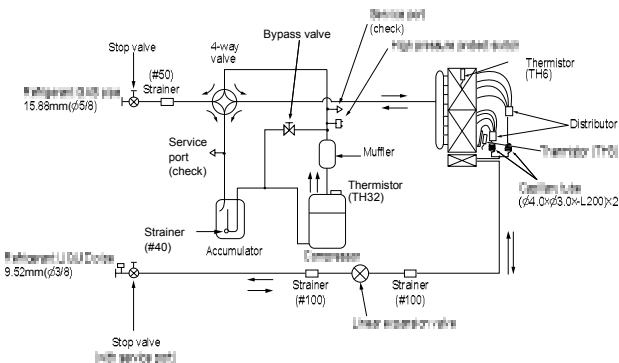

Unit : mm

PUHZ-P200YHA3
PUHZ-P250YHA3

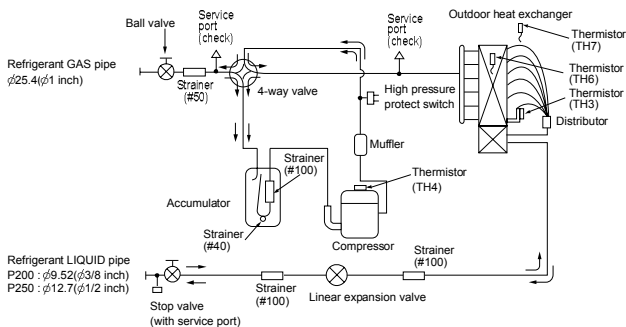
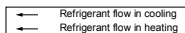

8-1. PIPE LENGTH

8-1-1. 1:1 SYSTEM and 1:2(1 indoor / 2 outdoor) SYSTEM

<Table 1-1> Maximum pipe length (P100-140)

Liquid pipe (mm)	ø9.52			ø12.7		
	Thickness	10.8			10.8	
Gas pipe (mm)	OD	ø12.7	ø15.88	ø19.05	ø15.88	ø19.05
	Thickness	10.8			11.0	
P100	Liquid pipe (mm)	ø12.7	Standard size	○	△	△
			50m [20m]	50m [20m]	25m [10m]	25m [10m]
P125,P140	Liquid pipe (mm)	ø12.7	Standard size	○	△	△
			50m [30m]	50m [30m]	30m [10m]	30m [10m]

<Marks in the table>

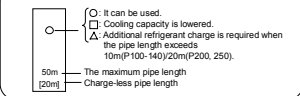

<Table 1-2> Maximum pipe length (P200, 250)

Liquid pipe (mm)	ø9.52			ø12.7			ø15.88				
	Thickness	10.8			10.8			11.0			
Gas pipe (mm)	OD	ø22.2	ø25.4	ø28.58	ø22.2	ø25.4	ø28.58	ø22.2	ø25.4	ø28.58	ø31.75
	Thickness	11.0			11.0			11.0			11.0
P200	Liquid pipe (mm)	ø22.2	Normal piping	○	□△	○	□△	○	□△	○	□△
			50m [30m]	70m [30m]	70m [30m]	50m [20m]	50m [20m]	50m [20m]	40m [20m]	40m [20m]	40m [20m]
P250	Liquid pipe (mm)	ø22.2	Normal piping	○	□△	○	□△	○	□△	○	□△
			50m [30m]	70m [30m]	70m [30m]	50m [30m]	70m [30m]	70m [30m]	45m [20m]	45m [20m]	45m [20m]

Note : Be sure to use hard (tempered) one for pipe over ø22.2.(Do not use soft (annealed) one.)

8-1-2. TWIN TRIPLE AND QUADRUPLE SYSTEM

(1) TWIN SYSTEM

<Table 2-1> Maximum pipe length(P100-140)

Main pipe (mm) [A]	Liquid pipe (mm)	P100(RP50X2)			P125(RP60X) P140(RP71X2)		
		ø9.52	ø9.52	ø12.7	ø9.52	ø9.52	ø12.7
Branch pipe (mm) [B, C]	Liquid pipe (mm)	ø6.35	Standard size	○	△	△	△
			50m [20m]	50m [20m]	25m [10m]	25m [10m]	25m [10m]
Branch pipe (mm) [B, C]	Gas pipe (mm)	ø12.7	Standard size	○	△	△	△
			50m [20m]	50m [20m]	25m [10m]	25m [10m]	25m [10m]
Branch pipe (mm) [B, C]	Gas pipe (mm)	ø9.52	Standard size	○	△	△	△
			50m [20m]	50m [20m]	25m [10m]	25m [10m]	25m [10m]
Branch pipe (mm) [B, C]	Gas pipe (mm)	ø15.88	Standard size	○	△	△	△
			50m [30m]	50m [30m]	30m [10m]	30m [10m]	30m [10m]

<Table 2-2> Maximum pipe length(P200, 250)

Main pipe (mm) [A]	Liquid pipe (mm)	P200(RP100X2)						P250(RP125X2)					
		ø9.52	ø9.52	ø12.7	ø12.7	ø15.88	ø15.88	ø9.52	ø9.52	ø12.7	ø12.7	ø15.88	ø15.88
Branch pipe (mm) [B, C]	Liquid pipe (mm)	ø9.52	Standard size	○	△	△	△	△	△	△	△	△	△
			50m [30m]	70m [30m]	70m [30m]	50m [20m]	50m [20m]	40m [20m]	40m [20m]	40m [20m]	40m [20m]	50m [30m]	70m [30m]
Branch pipe (mm) [B, C]	Gas pipe (mm)	ø15.88	Standard size	○	△	△	△	△	△	△	△	△	△
			50m [30m]	70m [30m]	70m [30m]	50m [20m]	50m [20m]	40m [20m]	40m [20m]	40m [20m]	50m [30m]	70m [30m]	70m [30m]

(2) TRIPLE SYSTEM

<Table 3-1> Maximum pipe length(P140)

Main pipe (mm) [A]	Liquid pipe (mm)	P140(RP50X3)			
		ø9.52	ø9.52	ø12.7	
Branch pipe (mm) [B, C, D]	Liquid pipe (mm)	ø6.35	Standard size	○	△
			50m [30m]	50m [30m]	30m [10m]
Branch pipe (mm) [B, C, D]	Gas pipe (mm)	ø12.7	Standard size	○	△
			50m [30m]	50m [30m]	30m [10m]
Branch pipe (mm) [B, C, D]	Gas pipe (mm)	ø9.52	Standard size	○	△
			50m [30m]	50m [30m]	30m [10m]
Branch pipe (mm) [B, C, D]	Gas pipe (mm)	ø15.88	Standard size	○	△
			50m [30m]	50m [30m]	10m [10m]

<Table 3-2> Maximum pipe length(P200, 250)

Main pipe (mm) [A]	Liquid pipe (mm)	P200(RP100X3)						P250(RP125X3)					
		ø9.52	ø9.52	ø12.7	ø12.7	ø15.88	ø15.88	ø9.52	ø9.52	ø12.7	ø12.7	ø15.88	ø15.88
Branch pipe (mm) [B, C]	Liquid pipe (mm)	ø9.52	Standard size	○	△	△	△	△	△	△	△	△	△
			50m [30m]	70m [30m]	70m [30m]	50m [20m]	50m [20m]	40m [20m]	40m [20m]	40m [20m]	50m [30m]	70m [30m]	70m [30m]
Branch pipe (mm) [B, C]	Gas pipe (mm)	ø15.88	Standard size	○	△	△	△	△	△	△	△	△	△
			50m [30m]	70m [30m]	70m [30m]	50m [20m]	50m [20m]	40m [20m]	40m [20m]	40m [20m]	50m [30m]	70m [30m]	70m [30m]

(3) QUADRUPLE SYSTEM

<Table 2-2> Maximum pipe length(P200, 250)

Main pipe (mm) [A]	Liquid pipe O.D. [B, C]	Gas pipe O.D. [B, C]	P200/RP60x4								P250/RP60x4													
			φ15.88				φ12.7				φ15.88				φ12.7									
			φ22.2	φ25.4	φ28.58	φ22.2	φ25.4	φ28.58	φ22.2	φ25.4	φ28.58	φ22.2	φ25.4	φ28.58	φ22.2	φ25.4	φ28.58	φ22.2	φ25.4	φ28.58	φ22.2	φ25.4	φ28.58	
			11.0	11.0	11.0	11.0	11.0	11.0	11.0	11.0	11.0	11.0	11.0	11.0	11.0	11.0	11.0	11.0	11.0	11.0	11.0	11.0	11.1	
			□	○	△	□	△	△	□	△	△	□	△	△	□	△	△	□	△	△	□	△	△	△
			50m [30m]	70m [30m]	70m [30m]	50m [20m]	50m [20m]	50m [20m]	40m [20m]	40m [20m]	40m [20m]	40m [20m]	40m [20m]	40m [20m]	40m [20m]	40m [20m]	40m [20m]	40m [20m]	40m [20m]	40m [20m]	40m [20m]	40m [20m]	40m [20m]	40m [20m]
			φ6.35	φ12.7	φ15.88	φ6.35	φ12.7	φ15.88	φ6.35	φ12.7	φ15.88	φ6.35	φ12.7	φ15.88	φ6.35	φ12.7	φ15.88	φ6.35	φ12.7	φ15.88	φ6.35	φ12.7	φ15.88	φ6.35

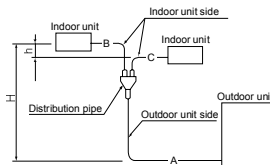

<TWIN SYSTEM>
Total length A + B + C
P100-140: 50 m
P200, 250: 70 m

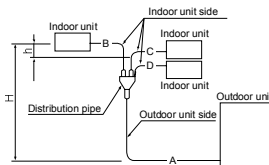

<TRIPLE SYSTEM>
Total length A + B + C + D
P140: 50 m
P200, 250: 70 m

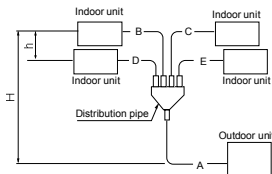

<QUADRUPLE SYSTEM>
Total length A + B + C + D + E
P200, 250 : 70 m

(4) Pipe size and refrigerant pipe limits

	Outdoor unit	Pipe size (mm)				Actual piping length <m>			Height difference <m>		(Note 1) No. of bend
		Gas side		Liquid side		Total length A+B+C+D+E	Indoor ~ Indoor	Branch pipe B, C, D	Indoor ~ Outdoor	Indoor ~ Indoor	
TWIN	100-140	φ15.88 <5/8>	RP50 φ12.7<1/2> RP60,71	φ9.52<3/8>	RP50 φ6.35<1/4> RP60,71 φ9.52<3/8>	50m	[B-C] 8m	20m	H30m	h 1m	15
TRIPLE	140										
TWIN	200, 250	φ25.4 <1>	RP60,71 100, 125 φ15.88<5/8>	φ9.52<3/8> (P200) φ12.7<1/2> (P250)	RP60,71 100, 125 φ9.52<3/8>	70m	[B-C] 8m	30m			
TRIPLE											
QUADRUPLE				RP50 φ12.7<1/2> RP60 φ15.88<5/8>		RP50 φ6.35<1/4> RP60 φ9.52<3/8>		[B-C] 8m			

Note1. The number of bends in the refrigerant pipe is respectively 8 or less in the range of <A+B> <A+C> <A+D>.

2. PUHZ-P100: 20 m chargeless

PUHZ-P125-250: 30 m chargeless

8-2. ADJUSTING THE AMOUNT OF REFRIGERANT

- Check additional refrigerant charging amount referring to table 5, 6 when liquid pipe is one size larger than standard diameter.

<Table 5> Required additional charge when the liquid pipe is one size larger than the standard diameter (1:1 SYSTEM)

	Liquid pipe dia.	Chargeless	Max. pipe length	Refrigerant amount to be added
P100	φ12.7	10m	25m	100 g per 1 m longer than 10 m
P125,140	φ12.7	10m	30m	100 g per 1 m longer than 10 m
P200	φ15.88	20m	40m	Additional refrigerant amount (Longer than 20 m)
P250	φ15.88	20m	45m	$\Delta W(g) = 180 \times \text{pipe length}(m) - 3000$

If the calculation produces a negative number ($\Delta W \leq 0$), additional charging is not necessary.

<Table 6> Required additional charge when the liquid pipe is one size larger than the standard diameter (TWIN/TRIPLE/QUADRUPLE SYSTEM)

Capacity	When the extension pipe length (main piping + branch piping) exceeds 10 m(P100-140)/20m(P200, 250)
P100, 125,140	Additional refrigerant amount $\Delta W(g) = (100 \times L2) + (60 \times L3) + (30 \times L4) - 2000$
P200, 250	Additional refrigerant amount $\Delta W(g) = (180 \times L1) + (120 \times L2) + (90 \times L3) + (30 \times L4) - 3000$

If the calculation produces a negative number ($\Delta W \leq 0$), additional charging is not necessary.

L1: φ15.88 liquid pipe length (m) L2: φ12.7 liquid pipe length (m)

L3: φ9.52 liquid pipe length (m) L4: φ6.35 liquid pipe length (m)

<Table 7> Additional refrigerant charging amount for pipe of standard diameter

Outdoor unit	Max. pipe length	Amount of unit filling refrigerant (kg)	Additional refrigerant charging amount for pipe length exceeding 30 m (kg)				
			21 — 30m	31 — 40m	41 — 50m	51 — 60m	61 — 70m
PUHZ-P100VHA3 PUHZ-P100YHA	50m	3.0kg	0.6kg	1.2kg	1.8kg	/	/
PUHZ-P125VHA3 PUHZ-P125YHA	50m	4.5kg	/	0.6kg	1.2kg	/	/
PUHZ-P140VHA3 PUHZ-P140YHA	50m	4.5kg	/	0.6kg	1.2kg	/	/
PUHZ-P200YHA3	70m	5.8kg	/	0.9kg	1.8kg	2.7kg	3.6kg
PUHZ-P250YHA3	70m	7.1kg	/	1.2kg	2.4kg	3.6kg	4.8kg

8-3. CAPACITY CURVE

■ PUHZ-P100/125/140VHA3, PUHZ-P100/125/140YHA <Standard size>

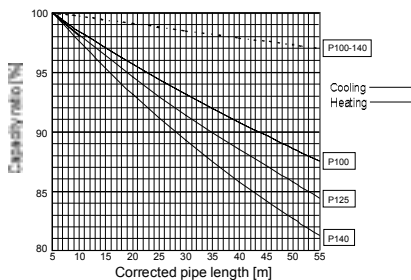

■ PUHZ-P200/250YHA3 <Standard size>

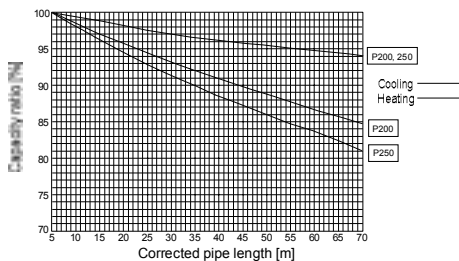

■ PUHZ-P200/250YHA3 <Gas pipe's diameter is one size smaller than the standard size>

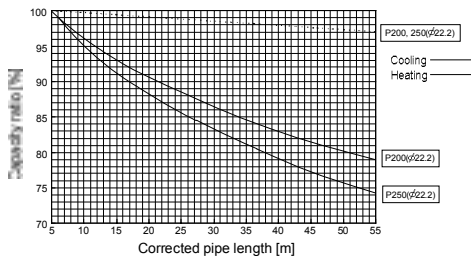

10-10. FUNCTION OF SWITCHES, CONNECTORS AND JUMPERS PUHZ-P

(1) Function of switches

Type of switch	Switch No.	Function	Action by the switch operation		Effective timing			
			ON	OFF				
Dip switch	SW1	1	Compulsory defrosting	Start	Normal	When compressor is working in heating operation. w		
		2	Abnormal history clear	Clear	Normal	off or operating		
		3	Refrigerant address setting					When power supply ON
		4						
		5						
		6						
		1		Test run	Operating	OFF	Under suspension	
		2		Test run mode setting	Heating	Cooling		

Compulsory defrosting should be done as follows.

1 Change the DIP SW1-1 on the outdoor controller board from OFF to ON.

2 Compulsory defrosting will start by the above operation 1 if these conditions written below are satisfied.

- Heat mode setting
- 10 minutes have passed since compressor started operating or previous compulsory defrosting finished.
- Pipe temperature is less than or equal to 8: .

3 Compulsory defrosting will finish if certain conditions are satisfied.

wCompulsory defrosting can be done if above conditions are satisfied when DIP SW1-1 is changed from OFF to ON.

After DIP SW1-1 is changed from OFF to ON, there is no problem if DIP SW1-1 is left ON or changed to OFF again. This depends on the service conditions.

Type of Switch	Switch No.	Function	Action by the switch operation		Effective timing														
			ON	OFF															
Dip switch	SW5	1	No function	—	—														
		2	Power failure automatic recovery w1	Auto recovery	No auto recovery	When power supply ON													
		3	No function	—	—	—													
		4	No function	—	—	—													
	SW7 v3	1	Setting of demand control w2	<table border="1"> <tr> <td>SW7-1</td> <td>SW7-2</td> <td>Power consumption (Demand switch ON)</td> </tr> <tr> <td>OFF</td> <td>OFF</td> <td>0% (Operation stop)</td> </tr> <tr> <td>ON</td> <td>OFF</td> <td>50%</td> </tr> <tr> <td>OFF</td> <td>ON</td> <td>75%</td> </tr> </table>			SW7-1	SW7-2	Power consumption (Demand switch ON)	OFF	OFF	0% (Operation stop)	ON	OFF	50%	OFF	ON	75%	Always
		SW7-1		SW7-2	Power consumption (Demand switch ON)														
		OFF	OFF	0% (Operation stop)															
		ON	OFF	50%															
		OFF	ON	75%															
		2																	
	3	Max Hz setting (cooling)	Max Hz(cooling) \circ 0.8	Normal	Always														
	4	Max Hz setting (heating)	Max Hz(heating) \circ 0.8	Normal	Always														
	5	Defrost Hz setting	Defrost Hz \circ 0.8	Normal	Always														
	6	No function	—	—	—														
	SW8	1	Use of existing pipe	Used	Not used	Always													
2		No function	—	—	—														
3		No function	—	—	—														
SW9	1	No function	—	—	—														
	2	No function	—	—	—														
Push switch	SWP	Pump down	Start	Normal	Under suspension														

*1 'Power failure automatic recovery' can be set by either remote controller or this DIP SW. If one of them is set to ON, 'Auto recovery' activates. Please set "Auto recovery" basically by remote controller because all units have not DIP SW. Please refer to the indoor unit installation manual.

*2 SW7-1,2 are used for demand control. SW7-1,2 are effective only at the demand control. (Refer to next page : Special function (b)).

*3 Please do not use SW7-3~6 usually. Trouble might be caused by the usage condition.

(2) Function of connectors and switches

Types	Connector Switch	Function	Action by open/ short operation		Effective timing																					
			Short	Open																						
Connector	CN31	Emergency operation	Start	Normal	When power supply ON																					
SW6 SW10	SW6-1	Model select	<table border="1"> <thead> <tr> <th>MODEL</th> <th>SW6</th> <th>SW10</th> </tr> </thead> <tbody> <tr> <td>100V</td> <td>ON OFF 1 2 3 4 5 6</td> <td>ON OFF 1 2</td> </tr> <tr> <td>125V</td> <td>ON OFF 1 2 3 4 5 6</td> <td>ON OFF 1 2</td> </tr> <tr> <td>140V</td> <td>ON OFF 1 2 3 4 5 6</td> <td>ON OFF 1 2</td> </tr> </tbody> </table>		MODEL	SW6	SW10	100V	ON OFF 1 2 3 4 5 6	ON OFF 1 2	125V	ON OFF 1 2 3 4 5 6	ON OFF 1 2	140V	ON OFF 1 2 3 4 5 6	ON OFF 1 2	<table border="1"> <thead> <tr> <th>MODEL</th> <th>SW6</th> <th>SW10</th> </tr> </thead> <tbody> <tr> <td>125V</td> <td>ON OFF 1 2 3 4 5 6</td> <td>ON OFF 1 2</td> </tr> <tr> <td>140V</td> <td>ON OFF 1 2 3 4 5 6</td> <td>ON OFF 1 2</td> </tr> </tbody> </table>	MODEL	SW6	SW10	125V	ON OFF 1 2 3 4 5 6	ON OFF 1 2	140V	ON OFF 1 2 3 4 5 6	ON OFF 1 2
	MODEL				SW6	SW10																				
	100V				ON OFF 1 2 3 4 5 6	ON OFF 1 2																				
	125V				ON OFF 1 2 3 4 5 6	ON OFF 1 2																				
	140V				ON OFF 1 2 3 4 5 6	ON OFF 1 2																				
	MODEL				SW6	SW10																				
	125V				ON OFF 1 2 3 4 5 6	ON OFF 1 2																				
140V	ON OFF 1 2 3 4 5 6	ON OFF 1 2																								
SW6-2																										
SW6-3																										
SW6-4																										
SW6-5																										
SW6-6																										
SW10-1																										
SW10-2																										

Special function

(a) Low-level sound priority mode (Local wiring)

Unit enters into Low-level sound priority mode by external signal input setting.

Inputting external signals to the outdoor unit decreases the outdoor unit operation sound 3 to 4 dB lower than that of usual.

Adding a commercial timer or on-off switch contactor setting to the CNDM connector which is optional contactor for Demand input located on the outdoor controller board enables to control compressor operation frequency.

WThe performance is depends on the load of conditioned outdoor temperature.

How to wiring

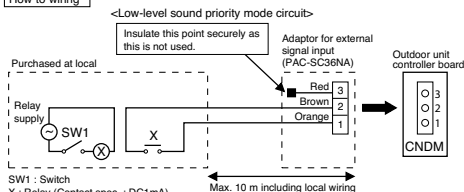

1) Make the circuit as shown above with Adaptor for external signal input(PAC-SC36NA).

2) Turn SW1 to on for Low-level sound priority mode.

Turn SW1 to off to release Low-level sound priority mode and normal operation.

(b) On demand control (Local wiring)

Demand control is available by external input. In this mode, power consumption is decreased within the range of usual 0~100%.

How to wiring

Basically, the wiring is the same (a).

Connect an SW 1 which is procured at field to the between Orange and Red(1 and 3) of the Adaptor for external signal input(PAC-SC36NA), and insulate the tip of the brown lead wire.

It is possible to set it to the following power consumption (compared with ratings) by setting the SW7-1, 2.

SW7-1	SW7-2	Power consumption (SW1 on)
OFF	OFF	0% (Operation stop)
ON	OFF	50%
OFF	ON	75%

CONFIGURACION SW3 SEZ/SLZ

SW3	FUNCION	OFF	ON
SW3-1	AUTO.RESTART	OFF	ON
SW3-2	4 GRADOS	HABILITADO	NO HABILITADO
SW3-3	VELOCIDAD CUANDO HEAT OFF	EXTRA LOW	STOP
SW3-4	-	-	-
SW3-5	FUNCIONES DE SW3	NO HABILITADAS	HABILITADAS

CONTROL A

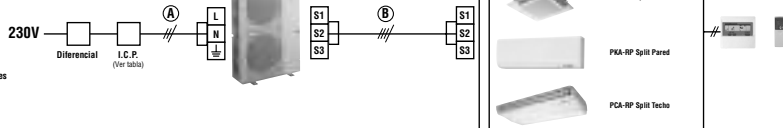

Unidades Exteriores

SUZ-KA35VA
 SUZ-KA50VA
 SUZ-KA60VA
 SUZ-KA71VA
 PUHZ-P100V
 PUHZ-P125V
 PUHZ-P140V

El circuito trigorífico con LEV (Válvula Expansión Línea) y un gran acumulador controlan siempre el nivel óptimo de refrigerante sin tener en cuenta la longitud de tubería (30 m máx. y 5 m mín) sin necesidad de añadir más gas. Para longitudes superiores a 30 mts, consulte la tabla inferior.

Datos de Instalación

MODELO	SECCIÓN A (mm ²)	SECCIÓN B (mm ²)	INTENSIDAD NOMINAL (A)		ICP. (A) CURVA C	TUB. FRIGOR.		DISTANCIAS FRIGORIFICAS (m)		PRECARGA DE GAS HASTA (m)	CARGA ADICIONAL (kg)
			FRIO	CALOR		LIQUIDO	GAS	MAXIMA VERTICAL	TOTAL VERTICAL + HORIZONTAL		
35	2 x 2,5 +T	3 x 2,5 +T	4,77	4,97	16	1/4"	3/8"	12	20	7	Ver Tabla
50	2 x 2,5 +T	3 x 2,5 +T	7,06	6,66	16	1/4"	1/2"	30	30	7	Ver Tabla
60	2 x 4 +T	3 x 2,5 +T	8,75	10,15	25	1/4"	5/8"	30	30	7	Ver Tabla
71	2 x 4 +T	3 x 2,5 +T	11,55	11,15	25	3/8"	5/8"	15	30	7	Ver Tabla
100	2 x 6 +T	3 x 2,5 +T	14,81	15,17	32	3/8"	5/8"	30	50	20	Ver Tabla
125	2 x 10 +T	3 x 2,5 +T	19,99	19,36	32	3/8"	5/8"	30	50	30	Ver Tabla
140	2 x 10 +T	3 x 2,5 +T	25,17	24	40	3/8"	5/8"	30	50	30	Ver Tabla

GAMA NO INVERTER

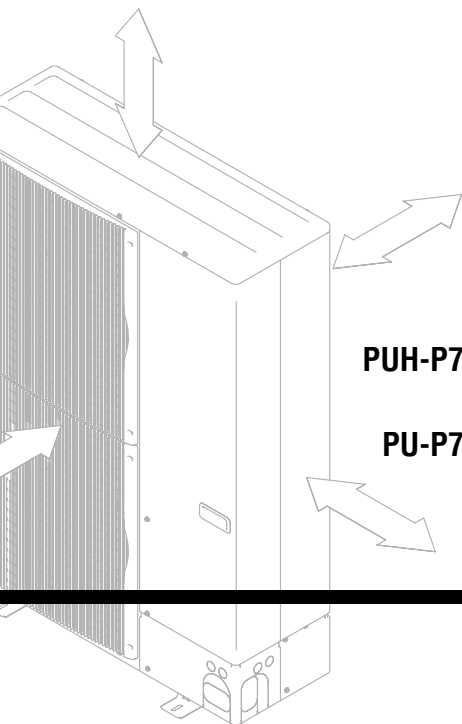

PLA-RP-AA
PEAD-RP-EA
PEAD-RP-GA
PKA-RP-GAL
PKA-RP-FAL
PCA-RP-GA
PSA-RP-GA

PUH-P71-100VHA
PUH-P71-100-125-140YHA
PU-P71-100VHA
PU-P71-100-125-140YHA

1. TIPO DE CASSETTE

Nombre del Modelo	Unidad Interior		PLA-RP71AA		PLA-RP100AA2		PLA-RP125AA2	PLA-RP140AA2	
	Unidad Exterior		PUH-P71VHA	PUH-P71YHA	PUH-P100VHA	PUH-P100YHA	PUH-P125VHA	PUH-P140YHA	
Refrigeración	Capacidad	Btu/h	27.300		34.100		42.000	48.500	
		kW	8,0		10,0		12,3	14,2	
	Consumo Total	kW	2,83		3,53		4,36	5,41	
	EER		2,83		2,83		2,82	2,62	
	Clase de etiqueta de energía			C		C		C	D
Calefacción	Capacidad	Btu/h	30.700 [37.300]		39.200		48.800	58.000	
		kW	9,0 [10,93]		11,5		14,3	17,0	
	Consumo Total	kW	2,82 [4,75]		3,40		4,23	5,35	
	COP		3,19		3,38		3,38	3,18	
	Clase de etiqueta de energía			D		C		C	D
	Calefactor impulsor		kW	[2,1]		-		-	-
Alimentación	Fase	∅	1	3	1	3	3		
	Frecuencia	Hz	50	50	50	50	50		
	Tensión	V	230	400	230	400	400		
	Llave térmica	A	32	16	32	16	25		
	Unidad Interior	Flujo de aire (Bajo-Medio2-Medio1-Alto)	m ³ /min pie ³ /min	15-16-18-20 530-565-635-705		19-21-23-27 670-740-810-950		24-25-27-30 850-880-950-1060	
	Presión externa	Pa	0		0		0		
	Nivel de ruido (Bajo-Medio2-Medio1-Alto)	dB(A)	28-30-32-34		33-36-39-41		37-40-43-45		
	Terminación externa (Panel)		Munsell Blanco 0,70Y 8,59/0,97						
	Dimensiones Unidad (Panel)	An : mm	840 (950)		840 (950)		840 (950)		
		Pr : mm	840 (950)		840 (950)		840 (950)		
		Al : mm	258 (30)		298 (30)		298 (30)		
		An : pulgada	33-1/16 (37-3/8)		33-1/16 (37-3/8)		33-1/16 (37-3/8)		
		Pr : pulgada	33-1/16 (37-3/8)		33-1/16 (37-3/8)		33-1/16 (37-3/8)		
		Al : pulgada	10-3/16 (1-3/16)		11-3/4 (1-3/16)		11-3/4 (1-3/16)		
	Peso Unidad (Panel)	kg	24 [26] [5]		32 [5]		32 [5]		
		lbs	53 [57] [11]		71 [11]		71 [11]		
	Cañería de drenaje de la unidad I.D.	mm	32		32		32		
		pulgada	1-1/4		1-1/4		1-1/4		
Unidad Exterior	Flujo de aire	m ³ /min	55		65		100		
		pie ³ /min	1.940		2.290		3.530		
	Nivel de ruido en refrigeración	dB(A)	49		50		50	51	
	Nivel de ruido en calefacción	dB(A)	50		52		52	53	
	Terminación externa			Munsell Marfil 5Y 7/1					
	Dimensiones	An : mm	950		950		950		
		Pr : mm	330+30		330+30		330+30		
		Al : mm	943		943		1350		
		An : pulgada	37-3/8		37-3/8		37-3/8		
		Pr : pulgada	13 + 1-3/16		13 + 1-3/16		13 + 1-3/16		
		Al : pulgada	37-1/8		37-1/8		53-1/8		
	WPeso	kg	93		94		131		
		lbs	205		207		289		
Tamaño de la cañería de refrigerante	Lado Gas O.D.	mm	15,88		15,88		15,88		
		pulgada	5/8		5/8		5/8		
	Lado Líquido O.D.	mm	9,52		9,52		9,52		
		pulgada	3/8		3/8		3/8		
Longitud de la cañería de refrigerante	Diferencia de altura	m	Máx. 50		Máx. 50		Máx. 50		
	Longitud	m	Máx. 50		Máx. 50		Máx. 50		

NOTA: 1. Condiciones de rango (ISO T1)

Refrigeración Interior : B.S. 27°C (80°F) B.H. 19,0 °C (66°F)

Exterior : B.S. 35°C (95°F) B.H. 24°C (75°F)

Calefacción Interior : B.S. 20°C (68°F)

Exterior : B.S. 7°C (45°F) B.H. 6°C (43°F)

Longitud de la cañería refrigerante (un sentido) : 5m (16 pie)

2. Rango de operación garantizado

		Interior	Exterior
Refrigeración	Lim. Superior	B.S. 35°C B.H. 22,5°C	B.S. 46°C
	Lim. Inferior	B.S. 19°C B.H. 15°C	B.S. -5°C *
Calefacción	Lim. Superior	B.S. 28°C	B.S. 21°C B.H. 15°C
	Lim. Inferior	B.S. 17°C	B.S. -11°C B.H. -12°C

3. Tensión garantizada

198-264V, 50Hz : Monofásico

342-457V, 50Hz : Trifásico

4. La información de arriba está basada en la tensión indicada

Unidad interior Monofásico 230V 50Hz

Unidad exterior Monofásico 230V 50Hz / trifásico 400V 50Hz

* Si se instala la guía de aire protegido opcional B.S. -15°C

Nombre del Modelo	Unidad Interior		PLA-RP71AA		PLA-RP100AA2		PLA-RP125AA2	PLA-RP140AA2	
	Unidad Exterior		PU-P71VHA	PU-P71YHA	PU-P100VHA	PU-P100YHA	PU-P125YHA	PU-P140YHA	
Refrigeración	Capacidad	Btu/h	27.300		34.100		42.000	48.000	
		kW	8,0		10,0		12,3	14,2	
	Consumo Total	kW	2,83		3,53		4,36	5,41	
	EER		2,83		2,83		2,82	2,62	
	Clase de etiqueta de energía		C		C		C	D	
	SHF	0,74		0,78		0,74	0,71		
Calefacción	Capacidad	Btu/h	-		-		-	-	
		kW	-		-		-	-	
	Consumo Total	kW	-		-		-	-	
	COP		-		-		-	-	
	Clase de etiqueta de energía		-		-		-	-	
	Calefactor impulsor		kW		-		-	-	
Alimentación	Fase	Ø	1	3	1	3	3		
	Frecuencia	Hz	50	50	50	50	50		
	Tensión	V	230	400	230	400	400		
	Llave térmica	A	32	16	32	16	25		
Unidad Interior	Flujo de aire (Bajo-Medio2-Medio1-Alto)	m ³ /min	15-16-18-20		19-21-23-27		24-25-27-30		
		pie ³ /min	530-565-635-705		670-740-810-950		850-880-950-1060		
	Presión externa	Pa	0		0		0		
	Nivel de ruido (Bajo-Medio2-Medio1-Alto)	A	28-30-32-34		33-36-39-41		37-40-43-45		
	Terminación externa (Panel)		Munsell Blanco 0,70Y 8,59/0,97						
	Dimensiones Unidad (Panel)	An : mm	840 (950)		840 (950)		840 (950)		
		Pr : mm	840 (950)		840 (950)		840 (950)		
		Al : mm	258 (30)		298 (30)		298 (30)		
		An : pulgada	33-1/16 (37-3/8)		33-1/16 (37-3/8)		33-1/16 (37-3/8)		
		Pr : pulgada	33-1/16 (37-3/8)		33-1/16 (37-3/8)		33-1/16 (37-3/8)		
Al : pulgada		10-3/16 (1-3/16)		11-3/4 (1-3/16)		11-3/4 (1-3/16)			
Peso	kg	24 (5)		32 (5)		32 (5)			
Unidad (Panel)	lbs	53 (11)		71 (11)		71 (11)			
	Cañería de drenaje de la unidad I.D.	mm	32		32		32		
	pulgada	1-1/4		1-1/4		1-1/4			
Unidad Exterior	Flujo de aire	m ³ /min	55		65		100		
		pie ³ /min	1.940		2.290		3.530		
	Nivel de ruido en refrigeración	dB(A)	49		50		50	51	
	Nivel de ruido en calefacción	dB(A)	-		-		-		
Terminación externa		Munsell Marfil 5Y 7/1							
Dimensiones	An : mm	950		950		950			
	Pr : mm	330+30		330+30		330+30			
	Al : mm	943		943		1350			
	An : pulgada	37-3/8		37-3/8		37-3/8			
	Pr : pulgada	13 + 1-3/16		13 + 1-3/16		13 + 1-3/16			
	Al : pulgada	37-1/8		37-1/8		53-1/8			
Peso	kg	93		94		131			
	lbs	205		207		289			
Tamaño de la cañería de refrigerante	Lado Gas O.D.	mm	15,88		15,88		15,88		
		pulgada	5/8		5/8		5/8		
	Lado Líquido O.D.	mm	9,52		9,52		9,52		
		pulgada	3/8		3/8		3/8		
Longitud de la cañería de refrigerante	Diferencia de altura	m	Máx. 50		Máx. 50		Máx. 50		
	Longitud	m	Máx. 50		Máx. 50		Máx. 50		

NOTA: 1. Condiciones de rango (ISO T1)
Refrigeración Interior : B.S. 27°C (80°F) B.H. 19,0 °C (66°F) Exterior : B.S. 35°C (95°F) B.H. 24°C (75°F)

Longitud de la cañería refrigerante (un sentido) : 5m (16 pie)

2. Rango de operación garantizado

3. Tensión garantizada
198-264V, 50Hz : Monofásico
342-457V, 50Hz : Trifásico
4. La información de arriba está basada en la tensión indicada
Unidad interior Monofásico 230V 50Hz
Unidad exterior Monofásico 230V 50Hz / trifásico 400V 50Hz

* Si se instala la guía de aire protegido opcional. B.S. -15°C

Refrigeración	Lim. Superior Lim. Inferior	Interior		Exterior
		B.S. 35°C B.S. 19°C	B.H. 22,5°C B.H. 15°C	B.S. 46°C B.S. -5°C
				*

2. TIPO DE CONDUCTOS

Nombre del Modelo	Unidad Interior		PEAD-RP71EA		PEAD-RP100EA2		PEAD-RP125EA	PEAD-RP140EA	
	Unidad Exterior		PUH-P71VHA	PUH-P71YHA	PUH-P100VHA	PUH-P100YHA	PUH-P125YHA	PUH-P140YHA	
Refrigeración	Capacidad	Btu/h	27.000		34.100		42.000	48.500	
		kW	7,9		10,0		12,3	14,2	
	Consumo Total	kW	2,97		3,69		4,41	5,63	
	EER		2,66		2,71		2,79	2,52	
	Clase de etiqueta de energía			D		D		D	E
	SHF			0,83		0,86		0,82	0,83
Calefacción	Capacidad	Btu/h	30.700 [37.300]		39.200 [46.800]		48.800 [58.200]	57.000 [66.400]	
		kW	9,0 [10,93]		11,5 [13,71]		14,3 [17,06]	16,7 [19,46]	
	Consumo Total	kW	3,11 [5,04]		3,42 [5,63]		4,32 [7,08]	5,28 [8,04]	
	COP		2,89		3,36		3,31	3,16	
	Clase de etiqueta de energía			D		C		C	D
	Calefactor impulsor		kW	[2,1]		[2,4]		[3,0]	[3,0]
Alimentación	Fase		∅						
	Frecuencia	Hz	50		50	50	50		
	Tensión	V	230		230	400	400		
	Llave térmica	A	32	16	32	16	25		
	Terminación externa		Galvanized sheets						
Unidad Interior	Flujo de aire (Bajo-Alto)	m ³ /min	20-25		33,5-42		33,5-42	36,5-46	
		pie ³ /min	706-883		1183-1483		1183-1483	1288-1624	
	Presión externa	Pa	70(130)		70(130)		70(130)		
	Nivel de ruido (Bajo-Alto)	dB(A)	37-41		44-50		44-50	46-51	
			130Pa : 40-45)		(130Pa : 46-52)		(130Pa : 46-52)	(130Pa : 47-53)	
	Terminación externa		Galvanized sheets						
	Dimensiones	An : mm	1175		1415		1415	1715	
			740		740		740		
		Al : mm	325		325		325		
			46-1/8		55-11/16		55-11/16	67-1/2	
		Pr : pulgada	29-1/8		29-1/8		29-1/8		
			Al : pulgada		12-13/16		12-13/16		
	Peso	kg	44 [46]		65 [68]		65 [68]	70 [73]	
		lbs	97 [101]		143 [150]		143 [150]	154 [161]	
	Cañería de drenaje de la unidad I.D.		pulgada		R1 (Malla externa)				
Unidad Exterior	Flujo de aire	m ³ /min	55		65		100		
		pie ³ /min	1.940		2.290		3.530		
	Nivel de ruido en refrigeración	dB(A)	49		50		50	51	
	Nivel de ruido en calefacción	dB(A)	50		52		52	53	
	Terminación externa		Munsell Marfil 5Y 7/1						
	Dimensiones	An : mm	950		950		950		
			Pr : mm		330+30		330+30		
		Al : mm	943		943		1350		
			An : pulgada		37-3/8		37-3/8		
		Pr : pulgada	13 + 1-3/16		13 + 1-3/16		13 + 1-3/16		
Al : pulgada			37-1/8		53-1/8				
Peso	kg	93		94		131			
	lbs	205		207		289			
Tamaño de la cañería de refrigerante	Lado Gas O.D.	mm	15,88		15,88		15,88		
		pulgada	5/8		5/8		5/8		
	Lado Líquido O.D.	mm	9,52		9,52		9,52		
		pulgada	3/8		3/8		3/8		
Longitud de la cañería de refrigerante	Diferencia de altura	m	Máx. 50		Máx. 50		Máx. 50		
	Longitud	m	Máx. 50		Máx. 50		Máx. 50		

NOTA: 1. Condiciones de rango (ISO T1)

Refrigeración Interior : B.S. 27°C (80°F) B.H. 19,0 °C (66°F)

Exterior : B.S. 35°C (95°F) B.H. 24°C (75°F)

Calefacción Interior : B.S. 20°C (68°F)

Exterior : B.S. 7°C (45°F) B.H. 6°C (43°F)

Longitud de la cañería refrigerante (un sentido) : 5m (16 pie)

2. Rango de operación garantizado

		Interior		Exterior	
		Lim. Superior	B.S. 35°C B.H. 22,5°C	B.S. 46°C	Lim. Superior
Refrigeración	Lim. Inferior	B.S. 28°C	B.S. 21°C B.H. 15°C	B.S. -5°C *	
	Lim. Inferior	B.S. 17°C	B.S. -11°C B.H. -12°C		
Calefacción	Lim. Superior	B.S. 28°C	B.S. 21°C B.H. 15°C		
	Lim. Inferior	B.S. 17°C	B.S. -11°C B.H. -12°C		

3. Tensión garantizada

198-264V, 50Hz : Monofásico

342-457V, 50Hz : Trifásico

4. La información de arriba está basada en la tensión indicada

Unidad interior Monofásico 230V 50Hz

Unidad exterior Monofásico 230V 50Hz /

trifásico 400V 50Hz

* Si se instala la guía de aire protegido opcional. B.S. -15°C

Nombre del Modelo	Unidad Interior		PEAD-RP71EA		PEAD-RP100EA2		PEAD-RP125EA	PEAD-RP140EA	
	Unidad Exterior		PU-P71VHA	PU-P71YHA	PU-P100VHA	PU-P100YHA	PU-P125YHA	PU-P140YHA	
Refrigeración	Capacidad	Btu/h	27.000		34.100		42.000	48.500	
		kW	7.9		10.0		12.3	14.2	
	Consumo Total		2.97		3.69		4.41	5.63	
	EER		2.66		2.71		2.79	2.52	
	Clase de etiqueta de energía		D		D		D	E	
Calefacción	Capacidad	Btu/h	-		-		-	-	
		kW	-		-		-	-	
	Consumo Total		-		-		-	-	
	COP		-		-		-	-	
	Clase de etiqueta de energía		-		-		-	-	
Alimentación	Calefactor impulsor		-		-		-	-	
	Fase	∅	1		1	3	3		
	Frecuencia	Hz	50		50	50	50		
	Tensión	V	230		230	400	400		
	Llave térmica	A	32	16	32	16	25		
Unidad Interior	Flujo de aire (Bajo-Alto)		m ³ /min		20-25		33.5-42	33.5-42	36.5-46
			pie ³ /min		706-883		1183-1483	1183-1483	1288-1624
	Presión externa		Pa		70(130)		70(130)	70(130)	
	Nivel de ruido (Bajo-Alto)		dB(A)		37-41		44-50	44-50	46-51
			(130Pa : 40-45)		(130Pa : 46-52)		130Pa : 46-52	(130Pa : 47-53)	
	Terminación externa		Hojas galvanizadas						
	Dimensiones	An : mm	1175		1415		1415	1715	
		Pr : mm	740		740		740		740
		Al : mm	325		325		325		325
		An : pulgada	46-1/8		55-11/16		55-11/16		67-1/2
		Pr : pulgada	29-1/8		29-1/8		29-1/8		29-1/8
		Al : pulgada	12-13/16		12-13/16		12-13/16		12-13/16
	Peso	kg	44		65		65	70	
lbs		97		143		143	154		
Cañería de drenaje de la unidad I.D.		mm		R1 (Malla externa)					
		pulgada							
Unidad Exterior	Flujo de aire		m ³ /min		55		65	100	
			pie ³ /min		1.940		2.290	3.530	
	Nivel de ruido en refrigeración		dB(A)		49		50	50	51
	Nivel de ruido en calefacción		dB(A)		-		-	-	-
	Terminación externa		Munsell Marfil 5Y 7/1						
	Dimensiones	An : mm	950		950		950		
		Pr : mm	330+30		330+30		330+30		
		Al : mm	943		943		1350		
		An : pulgada	37-3/8		37-3/8		37-3/8		
		Pr : pulgada	13 + 1-3/16		13 + 1-3/16		13 + 1-3/16		
Al : pulgada		37-1/8		37-1/8		53-1/8			
Peso	kg	93		94		131			
	lbs	205		207		289			
Tamaño de la cañería de refrigerante	Lado Gas O.D.	mm	15,88		15,88		15,88		
		pulgada	5/8		5/8		5/8		
	Lado Líquido O.D.	mm	9,52		9,52		9,52		
		pulgada	3/8		3/8		3/8		
Longitud de la cañería de refrigerante	Diferencia de altura	m	Máx. 50		Máx. 50		Máx. 50		
	Longitud	m	Máx. 50		Máx. 50		Máx. 50		

NOTA: 1. Condiciones de rango (ISO T1)
Refrigeración Interior : B.S. 27°C (80°F) B.H. 19.0 °C (66°F) Exterior : B.S. 35°C (95°F) B.H. 24°C (75°F)

Longitud de la cañería refrigerante (un sentido) : 5m (16 pie)

2. Rango de operación garantizado

Refrigeración	Lim. Superior Lim. Inferior	Interior	Exterior
		B.S. 35°C. B.H. 22.5°C	B.S. 46°C

3. Tensión garantizada
198-264V, 50Hz : Monofásico
342-457V, 50Hz : Trifásico
4. La información de arriba está basada en la tensión indicada
Unidad interior Monofásico 230V 50Hz
Unidad exterior Monofásico 230V 50Hz / Trifásico 400V 50Hz
- * Si se instala la guía de aire protegido opcional. B.S. -15°C

Nombre del Modelo	Unidad Interior		PEAD-RP71GA		PEAD-RP100GA	
	Unidad Exterior		PUH-P71VHA	PUH-P71YHA	PUH-P100VHA	PUH-P100YHA
Refrigeración	Capacidad	Btu/h	27.000		33.100	
		kW	7,9		9,7	
	Consumo Total	kW	2,97		3,98	
	EER		2,66		2,44	
	Clase de etiqueta de energía		D		E	
Calefacción	Capacidad	Btu/h	30.700		39.200	
		kW	9,0		11,5	
	Consumo Total	kW	3,11		4,09	
	COP		2,89		2,81	
	Clase de etiqueta de energía		D		D	
Alimentación	Calefactor impulsor	kW	-		-	
	Fase	Ø	1 3		1 3	
	Frecuencia	Hz	50		50	
	Tensión	V	230		230	
	Llave térmica	A	32		32	
Unidad Interior	Flujo de aire (Bajo-Alto)	m³/min	20-25		26,5-33	
		pie³/min	706-883		935-1165	
	Presión externa	Pa	10/50/70		10/50/70	
	Nivel de ruido (Bajo-Alto)	dB(A)	35-38/37-41/37-43		40-43/42-45/42-46	
			10/50/70Pa		(10/50/70Pa)	
	Terminación externa		Hojas galvanizadas			
	Dimensiones	An : mm	1171		1411	
		Pr : mm			740	
		Al : mm			275	
		An : pulgada	46-1/8		55-9/16	
Pr : pulgada				29-1/8		
Al : pulgada				10-13/16		
Peso	kg	42		50		
	lbs	93		111		
Cañería de drenaje de la unidad I.D.	mm			32		
	pulgada			1-1/4		
Unidad Exterior	Flujo de aire	m³/min	55		65	
		pie³/min	1.940		2.290	
	Nivel de ruido en refrigeración	dB(A)	49		50	
	Nivel de ruido en calefacción	dB(A)	50		52	
	Terminación externa		Munsell Marfil 5Y 7/1			
	Dimensiones	An : mm	950		950	
		Pr : mm	330+30		330+30	
		Al : mm	943		943	
		An : pulgada	37-3/8		37-3/8	
		Pr : pulgada	13 + 1-3/16		13 + 1-3/16	
Al : pulgada		37-1/8		37-1/8		
Peso	kg	93		94		
	lbs	205		207		
Tamaño de la cañería de refrigerante	Lado Gas O.D.	mm	15,88		15,88	
		pulgada	5/8		5/8	
	Lado Líquido O.D.	mm	9,52		9,52	
		pulgada	3/8		3/8	
Longitud de la cañería de refrigerante	Diferencia de altura	m	Máx. 50		Máx. 50	
	Longitud	m	Máx. 50		Máx. 50	

NOTA: 1. Condiciones de rango (ISO T1)
 Refrigeración Interior : B.S. 27°C (80°F) B.H. 19,0 °C (66°F)
 Calefacción Interior : B.S. 20°C (68°F)

Exterior : B.S. 35°C (95°F) B.H. 24°C (75°F)
 Exterior : B.S. 7°C (45°F) B.H. 6°C (43°F)

Longitud de la cañería refrigerante (un sentido) : 5m (16 pie)

2. Rango de operación garantizado

	Interior		Exterior	
	Lim. Superior	B.S. 35°C. B.H. 22.5°C	B.S. 46°C	
Refrigeración	Lim. Inferior	B.S. 19°C. B.H. 15°C	B.S. -5°C	*
	Lim. Superior	B.S. 28°C	B.S. 21°C. B.H. 15°C	
Calefacción	Lim. Inferior	B.S. 17°C	B.S. -11°C. B.H. -12°C	

3. Tensión garantizada
 198-264V, 50Hz : Monofásico
 342-457V, 50Hz : Trifásico

4. La información de arriba está basada en la tensión indicada
 Unidad Interior Monofásico 230V 50Hz
 Unidad exterior Monofásico 230V 50Hz /
 trifásico 400V 50Hz

* Si se instala la guía de aire protegido opcional. B.S. -15°C

Nombre del Modelo	Unidad Interior		PEAD-RP71GA		PEAD-RP100GA	
	Unidad Exterior		PU-P71VHA	PU-P71YHA	PU-P100VHA	PU-P100YHA
Refrigeración	Capacidad	Btu/h	27.000		33.100	
		kW	7.9		9.7	
	Consumo Total	kW	2.97		3.98	
	EER		2.66		2.44	
	Clase de etiqueta de energía		D		E	
Calefacción	Capacidad	Btu/h	-		-	
		kW	-		-	
	Consumo Total	kW	-		-	
	COP		-		-	
	Clase de etiqueta de energía		-		-	
Alimentación	Calefactor impulsor	kW	-		-	
	Fase	∅	1	3	1	3
	Frecuencia	Hz	50	50	50	50
	Tensión	V	230	400	230	400
	Llave térmica	A	32	16	32	16
Unidad Interior	Flujo de aire (Bajo-Alto)	m ³ /min	20-25		26.5-33	
		pie ³ /min	706-883		935-1165	
	Presión externa	Pa	10/50/70		10/50/70	
	Nivel de ruido (Bajo-Alto)	dB(A)	35-38/37-41/37-43 10/50/70Pa)		40-43/42-45/42-46 (10/50/70Pa)	
	Terminación externa		Hojas galvanizadas			
	Dimensiones	An : mm	1171		1411	
		Pr : mm			740	
		Al : mm			275	
		An : pulgada	46-1/8		55-9/16	
		Pr : pulgada			29-1/8	
Al : pulgada				10-13/16		
Peso	kg	42		50		
	lbs	93		111		
	Cañería de drenaje de la unidad I.D.	mm	32		32	
	pulgada	1-1/4		1-1/4		
Unidad Exterior	Flujo de aire	m ³ /min	55		65	
		pie ³ /min	1.940		2.290	
	Nivel de ruido en refrigeración	dB(A)	49		50	
	Nivel de ruido en calefacción	dB(A)	-		-	
	Terminación externa		Munsell Marfil 5Y 7/1			
	Dimensiones	An : mm	950		950	
		Pr : mm	330+30		330+30	
		Al : mm	943		943	
		An : pulgada	37-3/8		37-3/8	
		Pr : pulgada	13 + 1-3/16		13 + 1-3/16	
Al : pulgada		37-1/8		37-1/8		
Peso	kg	93		94		
	lbs	205		207		
	Lado Gas O.D.	mm	15,88		15,88	
Lado Líquido O.D.	pulgada	5/8		5/8		
	mm	9,52		9,52		
	pulgada	3/8		3/8		
Longitud de la cañería de refrigerante	Diferencia de altura	m	Máx. 50		Máx. 50	
	Longitud	m	Máx. 50		Máx. 50	

NOTA: 1. Condiciones de rango (ISO T1)
Refrigeración Interior : B.S. 27°C (80°F) B.H. 19,0 °C (66°F) Exterior : B.S. 35°C (95°F) B.H. 24°C (75°F)

Longitud de la cañería refrigerante (un sentido) : 5m (16 pie)
2. Rango de operación garantizado

Refrigeración	Lim. Superior Lim. Inferior	Interior	Exterior
		B.S. 35°C. B.H. 22.5°C B.S. 19°C. B.H. 15°C	B.S. 46°C B.S. -5°C

3. Tensión garantizada
198-264V, 50Hz : Monofásico
342-457V, 50Hz : Trifásico
4. La información de arriba está basada en la tensión indicada
Unidad interior Monofásico 230V 50Hz
Unidad exterior Monofásico 230V 50Hz /
trifásico 400V 50Hz

* Si se instala la guía de aire protegido opcional. B.S. -15°C

3. TIPO TECHO

Nombre del Modelo	Unidad Interior		PCA-RP71GA		PCA-RP100GA		PCA-RP125GA	PCA-RP140GA
	Unidad Exterior		PUH-P71VHA	PUH-P71YHA	PUH-P100VHA	PUH-P100YHA	PUH-P125YHA	PUH-P140YHA
Refrigeración	Capacidad	Btu/h	25.900		33.400		42.000	48.500
		kW	7,6		9,8		12,3	14,2
	Consumo Total	kW	2,84		3,55		4,52	5,44
	EER		2,68		2,76		2,72	2,61
	Clase de etiqueta de energía		D		D		D	D
	SHF		0,74		0,75		0,77	0,75
Calefacción	Capacidad	Btu/h	30.000 [36.600]		39.200 [47.700]		48.800 [58.200]	58.000 [67.400]
		kW	8,8 [10,73]		11,5 [13,98]		14,3 [17,06]	17,0 [19,76]
	Consumo Total	kW	2,76 [4,69]		3,45 [5,93]		4,72 [7,48]	5,22 [7,98]
	COP		3,19		3,33		3,03	3,26
	Clase de etiqueta de energía		D		C		D	C
	Calefactor impulsor	kW	[2,1]		[2,7]		[3,0]	[3,0]
Alimentación	Fase	Ø	1	3	1	3		3
	Frecuencia	Hz	50	50	50	50		50
	Tensión	V	230	400	230	400		400
	Linea térmica	A	32	16	32	16		25
Unidad Interior	Flujo de aire (Bajo-Medio2-Medio1-Alto)	m ³ /min	14-15-16-18		20-21-23-25		27-30-32-34	
		pie ³ /min	495-530-565-635		705-810-840-885		955-1060-1130-1200	
	Presión externa	Pa	0		0		0	
	Nivel de ruido (Bajo-Medio2-Medio1-Alto)	A	37-39-41-43		40-41-43-45		41-43-45-46 42-44-46-48	
	Terminación externa (Panel)		Munsell Blanco 0,70Y 8,59/0,97					
	Dimensiones Unidad (Panel)	An : mm	1310		1310		1620	
		Pr : mm	680		680		680	
		Al : mm	210		270		270	
		An : pulgada	51-9/16		51-9/16		63-3/4	
		Pr : pulgada	26-3/4		26-3/4		26-3/4	
	Al : pulgada	8-1/4		10-5/8		10-5/8		
Peso Unidad (Panel)	kg	34 [36]		37 [39,5]		43 [46]		
	lbs	75 [79]		82 [87]		95 [101]		
Cañería de drenaje de la unidad I.D.	mm	26						
	pulgada	1						
Unidad Exterior	Flujo de aire	m ³ /min	55		65		100	
		pie ³ /min	1.940		2.290		3.530	
	Nivel de ruido en refrigeración	dB(A)	49		50		50 51	
	Nivel de ruido en calefacción	dB(A)	50		52		52 53	
Terminación externa		Munsell Marfil 5Y 7/1						
Dimensiones	An : mm	950		950		950		
	Pr : mm	330+30		330+30		330+30		
	Al : mm	943		943		1350		
	An : pulgada	37-3/8		37-3/8		37-3/8		
	Pr : pulgada	13 + 1-3/16		13 + 1-3/16		13 + 1-3/16		
	Al : pulgada	37-1/8		37-1/8		53-1/8		
Peso	kg	93		94		131		
	lbs	205		207		289		
Tamaño de la cañería de refrigerante	Lado Gas O.D.	mm	15,88		15,88		15,88	
		pulgada	5/8		5/8		5/8	
	Lado Líquido O.D.	mm	9,52		9,52		9,52	
		pulgada	3/8		3/8		3/8	
Longitud de la cañería de refrigerante	Diferencia de altura	m	Máx. 50		Máx. 50		Máx. 50	
	Longitud	m	Máx. 50		Máx. 50		Máx. 50	

NOTA: 1. Condiciones de rango (ISO T1)

Refrigeración Interior : B.S. 27°C (80°F) B.H. 19,0 °C (66°F)

Exterior : B.S. 35°C (95°F) B.H. 24°C (75°F)

Calefacción Interior : B.S. 20°C (68°F)

Exterior : B.S. 7°C (45°F) B.H. 6°C (43°F)

Longitud de la cañería refrigerante (un sentido) : 5m (16 pie)

2. Rango de operación garantizado

		Interior	Exterior
Refrigeración	Lim. Superior	B.S. 35°C B.H. 22,5°C	B.S. 46°C
	Lim. Inferior	B.S. 19°C B.H. 15°C	B.S. -5°C
Calefacción	Lim. Superior	B.S. 28°C	B.S. 21°C B.H. 15°C
	Lim. Inferior	B.S. 17°C	B.S. -11°C B.H. -12°C

3. Tensión garantizada

198-264V, 50Hz : Monofásico

342-457V, 50Hz : Trifásico

4. La información de arriba está basada en la tensión indicada

Unidad interior Monofásico 230V 50Hz

Unidad exterior Monofásico 230V 50Hz / trifásico 400V 50Hz

* Si se instala la guía de aire protegido opcional. B.S. -15°C

Nombre del Modelo	Unidad Interior		PCA-RP71GA		PCA-RP100GA		PCA-RP125GA	PCA-RP140GA		
	Unidad Exterior		PU-P71VHA	PU-P71YHA	PU-P100VHA	PU-P100YHA	PU-P125YHA	PU-P140YHA		
Refrigeración	Capacidad	Btu/h	25.900		33.400		42.000	48.500		
		kW	7,6		9,8		12,3	14,2		
	Consumo Total	kW	2,84		3,55		4,52	5,44		
	EER		2,68		2,76		2,72	2,61		
	Clase de etiqueta de energía			D		D		D	D	
Calefacción	Capacidad	Btu/h	-		-		-	-		
		kW	-		-		-	-		
	Consumo Total	kW	-		-		-	-		
	COP			-		-		-	-	
	Clase de etiqueta de energía			-		-		-	-	
Alimentación	Calefactor impulsor		kW		-		-	-		
	Fase	∅	1	3	1	3	3			
	Frecuencia	Hz	50	50	50	50	50			
	Tensión	V	230	400	230	400	400			
	Llave térmica	A	32	16	32	16	25			
Unidad Interior	Flujo de aire (Bajo-Medio2-Medio1-Alto)		m ³ /min		14-15-16-18		20-21-23-25		27-30-32-34	
			pie ³ /min		495-530-565-635		705-810-840-885		955-1060-1130-1200	
	Presión externa		Pa		0		0		0	
	Nivel de ruido (Bajo-Medio2-Medio1-Alto)		A		37-39-41-43		40-41-43-45		41-43-45-46	42-44-46-48
	Terminación externa (Panel)				Munsell Blanco 0,70Y 8,5/9,0,97					
	Dimensiones	Unidad (Panel)	An : mm	1310		1310		1620		
			Pr : mm	680		680		680		
			Al : mm	210		270		270		
			An : pulgada	51-9/16		51-9/16		63-3/4		
			Pr : pulgada	26-3/4		26-3/4		26-3/4		
Al : pulgada			8-1/4		10-5/8		10-5/8			
Peso	kg	34		37		43	45			
	Unidad (Panel)	lbs	75		82		95	99		
Cañería de drenaje de la unidad I.D.		mm		26		26		26		
		pulgada		1		1		1		
Unidad Exterior	Flujo de aire		m ³ /min		55		65	100		
			pie ³ /min		1.940		2.290	3.530		
	Nivel de ruido en refrigeración		dB(A)		49		50	51		
	Nivel de ruido en calefacción		dB(A)		-		-	-		
	Terminación externa				Munsell Marfil 5Y 7/1					
Dimensiones	Unidad (Panel)	An : mm	950		950		950			
		Pr : mm	330+30		330+30		330+30			
		Al : mm	943		943		1350			
		An : pulgada	37-3/8		37-3/8		37-3/8			
		Pr : pulgada	13 + 1-3/16		13 + 1-3/16		13 + 1-3/16			
		Al : pulgada	37-1/8		37-1/8		53-1/8			
Peso	kg	93		94		131				
	lbs	205		207		289				
Tamaño de la cañería de refrigerante	Lado Gas O.D.	mm	15,88		15,88		15,88			
		pulgada	5/8		5/8		5/8			
	Lado Líquido O.D.	mm	9,52		9,52		9,52			
		pulgada	3/8		3/8		3/8			
Longitud de la cañería de refrigerante	Diferencia de altura	m	Máx. 50		Máx. 50		Máx. 50			
	Longitud	m	Máx. 50		Máx. 50		Máx. 50			

NOTA: 1. Condiciones de rango (ISO T1)
Refrigeración : B.S. 27°C (80°F) B.H. 19,0 °C (66°F) Exterior : B.S. 35°C (95°F) B.H. 24°C (75°F)

Longitud de la cañería refrigerante (un sentido) : 5m (16 pie)

2. Rango de operación garantizado

Refrigeración	Lim. Superior	Interior		Exterior
		B.S. 35°C. B.H. 22,5°C	B.S. 19°C. B.H. 15°C	B.S. 46°C
	Lim. Inferior	B.S. 19°C. B.H. 15°C	B.S. -5°C *	

3. Tensión garantizada
198-264V, 50Hz : Monofásico
342-457V, 50Hz : Trifásico

4. La información de arriba está basada en la tensión indicada
Unidad interior : Monofásico 230V 50Hz
Unidad exterior : Monofásico 230V 50Hz /
trifásico 400V 50Hz

* Si se instala la guía de aire protegido opcional. B.S. -15°C

Nombre del Modelo	Unidad Interior		PCA-RP71HA		PCA-RP125HA
	Unidad Exterior		PUH-P71VHA	PUH-P71YHA	PUH-P125YHA
Refrigeración	Capacidad	Btu/h	25.600		42.000
		kW	7,5		12,3
	Consumo Total	kW	2,79		4,55
	EER		2,69		2,70
	Clase de etiqueta de energía		D		D
Calefacción	Capacidad	Btu/h	30.400		48.800
		kW	8,9		14,3
	Consumo Total	kW	2,85		5,01
	COP		3,12		2,85
	Clase de etiqueta de energía		D		D
Alimentación	Calefactor impulsor	kW	-		-
	Fase	Ø	1		3
	Frecuencia	Hz	50		50
	Tensión	V	230		400
	Llave térmica	A	32		16
Unidad Interior	Flujo de aire (Bajo-Alto)	m³/min	17-19		30-38
		pie³/min	600-670		1060-1350
	Presión externa	Pa	0		0
	Nivel de ruido (Bajo-Alto)	dB(A)	34-38		44-50
	Terminación externa		Acero inoxidable		
	Dimensiones	An : mm	1136		1520
		Pr : mm	650		
		Al : mm	280		
		An : pulgada	44-3/4		59-7/8
		Pr : pulgada	25-5/8		
	Peso	kg	41		56
		lbs	90		124
Cañería de drenaje de la unidad I.D.		26			
	pulgada	1			
Unidad Exterior	Flujo de aire	m³/min	55		100
		pie³/min	1.940		3.530
	Nivel de ruido en refrigeración	dB(A)	49		50
	Nivel de ruido en calefacción	dB(A)	50		52
	Terminación externa		Munsell Marfil 5Y 7/1		
Dimensiones	An : mm	950		950	
	Pr : mm	330+30		330+30	
	Al : mm	943		1350	
	An : pulgada	37-3/8		37-3/8	
	Pr : pulgada	13 + 1-3/16		13 + 1-3/16	
Peso	kg	93		131	
	lbs	205		289	
	Tamaño de la cañería de refrigerante	Lado Gas O.D.	mm	15,88	
		pulgada	5/8		
Lado Líquido O.D.	mm	9,52		9,52	
	pulgada	3/8		3/8	
Longitud de la cañería de refrigerante	Diferencia de altura	m	Máx. 50		
	Longitud	m	Máx. 50		

- NOTA: 1. Condiciones de rango (ISO T1)
 Refrigeración Interior : B.S. 27°C (80°F) B.H. 19,0 °C (66°F) Exterior : B.S. 35°C (95°F) B.H. 24°C (75°F)
 Calefacción Interior : B.S. 20°C (68°F) Exterior : B.S. 7°C (45°F) B.H. 6°C (43°F)

Longitud de la cañería refrigerante (un sentido) : 5m (16 pie)

2. Rango de operación garantizado

		Interior	Exterior
Refrigeración	Lim. Superior	B.S. 35°C B.H. 22,5°C	B.S. 46°C
	Lim. Inferior	B.S. 19°C B.H. 15°C	B.S. -5°C *
Calefacción	Lim. Superior	B.S. 28°C	B.S. 21°C B.H. 15°C
	Lim. Inferior	B.S. 17°C	B.S. -11°C B.H. -12°C

3. Tensión garantizada

198-264V, 50Hz : Monofásico
 342-457V, 50Hz : Trifásico

4. La información de arriba está basada en la tensión indicada

Unidad interior Monofásico 230V 50Hz
 Unidad exterior Monofásico 230V 50Hz /
 trifásico 400V 50Hz

* Si se instala la guía de aire protegido opcional. B.S. -15°C

Nombre del Modelo	Unidad Interior		PCA-RP71HA		PCA-RP125HA	
	Unidad Exterior		PU-P71VHA	PU-P71YHA	PU-P125YHA	
Refrigeración	Capacidad	Btu/h	25-600		42.000	
		kW	7,5		12,3	
	Consumo Total		2,79		4,55	
	EER		2,69		2,70	
	Clase de etiqueta de energía		D		D	
Calefacción	Capacidad	Btu/h	-		-	
		kW	-		-	
	Consumo Total		-		-	
	COP		-		-	
	Clase de etiqueta de energía		-		-	
	Calefactor impulsor		-		-	
Alimentación	Fase	Ø	1	3	3	
	Frecuencia	Hz	50	50	50	
	Tensión	V	230	400	400	
	Llave térmica	A	32	16	25	
Unidad Interior	Flujo de aire (Bajo-Alto)	m ³ /min	17-19		30-38	
		pie ³ /min	600-670		1060-1350	
	Presión externa	Pa	0		0	
	Nivel de ruido (Bajo-Alto)	dB(A)	34-38		44-50	
			Terminación externa Acero inoxidable			
	Dimensiones	An : mm	1136		1520	
		Pr : mm	650			
		Al : mm	280			
		An : pulgada	44-3/4		59-7/8	
		Pr : pulgada	25-5/8			
Al : pulgada		11				
Peso	kg	41		56		
	lbs	90		124		
Cañería de drenaje de la unidad I.D.	mm	26				
	pulgada	1				
Unidad Exterior	Flujo de aire	m ³ /min	55		100	
		pie ³ /min	1.940		3.530	
	Nivel de ruido en refrigeración	dB(A)	49		50	
	Nivel de ruido en calefacción	dB(A)	-		-	
	Terminación externa		Munsell Marfil 5Y 7/1			
	Dimensiones	An : mm	950		950	
Pr : mm		330+30		330+30		
Al : mm		943		1350		
An : pulgada		37-3/8		37-3/8		
Pr : pulgada		13 + 1-3/16		13 + 1-3/16		
Al : pulgada		37-1/8		53-1/8		
Peso	kg	93		131		
	lbs	205		289		
Tamaño de la cañería de refrigerante	Lado Gas O.D.	mm	15,88		15,88	
		pulgada	5/8		5/8	
	Lado Líquido O.D.	mm	9,52		9,52	
		pulgada	3/8		3/8	
Longitud de la cañería de refrigerante	Diferencia de altura	m	Máx. 50		Máx. 50	
	Longitud	m	Máx. 50		Máx. 50	

NOTA: 1. Condiciones de rango (ISO T1)
Refrigeración Interior : B.S. 27°C (80°F) B.H. 19,0 °C (66°F) Exterior : B.S. 35°C (95°F) B.H. 24°C (75°F)

2. Longitud de la cañería refrigerante (un sentido) : 5m (16 pie)
Rango de operación garantizado

Refrigeración	Lim. Superior Lim. Inferior	Interior	Exterior
		B.S. 35°C B.H. 22,5°C	B.S. 46°C

3. Tensión garantizada
198-254V, 50Hz : Monofásico
342-457V, 50Hz : Trifásico
4. La información de arriba está basada en la tensión indicada
Unidad interior Monofásico 230V 50Hz
Unidad exterior Monofásico 230V 50Hz /
trifásico 400V 50Hz

* Si se instala la guía de aire protegido opcional. B.S. -15°C

4. TIPO MURAL

Nombre del Modelo	Unidad Interior		PKA-RP71FAL		PKA-RP100FAL	
	Unidad Exterior		PUH-P71VHA	PUH-P71YHA	PUH-P100VHA	PUH-P100YHA
Refrigeración	Capacidad	Btu/h	27.000		33.400	
		kW	7,9		9,8	
	Consumo Total	kW	2,84		3,50	
	EER		2,78		2,80	
	Clase de etiqueta de energía		D		D	
Calefacción	Capacidad	Btu/h	30.000 [36.600]		39.200 [46.800]	
		kW	8,8 [10,73]		11,5 [13,71]	
	Consumo Total	kW	3,08 [5,01]		3,47 [5,68]	
	COP		2,86		3,31	
	Clase de etiqueta de energía		D		D	
Alimentación	Calefactor impulsor	kW	[2,1]		[2,4]	
	Fase	∅	1	3	1	3
	Frecuencia	Hz	50	50	50	50
	Tensión	V	230	400	230	400
	Llave térmica	A	32	16	32	16
Unidad Interior	Flujo de aire (Bajo-Alto)	m ³ /min	15-20		22-28	
		pie ³ /min	530-705		780-990	
	Presión externa	Pa	0		0	
	Nivel de ruido (Bajo-Alto)	dB(A)	39-45		41-46	
	Terminación externa		Munsell 3,4Y 7,7/0,8			
	Dimensiones	An : mm	1400		1680	
		Pr : mm			235	
		Al : mm			340	
		An : pulgada	55-1/8		66-1/8	
	Pr : pulgada			9-1/4		
Al : pulgada			13-3/8			
Peso	kg	24 [26]		28 [30]		
	lbs	53 [57]		62 [66]		
Cañería de drenaje de la unidad I.D.	mm			20		
	pulgada			13/16		
Unidad Exterior	Flujo de aire	m ³ /min	55		65	
		pie ³ /min	1.940		2.290	
	Nivel de ruido en refrigeración	dB(A)	49		50	
	Nivel de ruido en calefacción	dB(A)	50		52	
Terminación externa		Munsell Marfil 5Y 7/1				
Dimensiones	An : mm	950		950		
	Pr : mm	330+30		330+30		
	Al : mm	943		943		
	An : pulgada	37-3/8		37-3/8		
	Pr : pulgada	13 + 1-3/16		13 + 1-3/16		
	Al : pulgada	37-1/8		37-1/8		
Peso	kg	93		94		
	lbs	205		207		
Tamaño de la cañería de refrigerante	Lado Gas O.D.	mm	15,88		15,88	
		pulgada	5/8		5/8	
	Lado Líquido O.D.	mm	9,52		9,52	
		pulgada	3/8		3/8	
Longitud de la cañería de refrigerante	Diferencia de altura	m	Máx. 50		Máx. 50	
	Longitud	m	Máx. 50		Máx. 50	

NOTA: 1. Condiciones de rango (ISO T1)
Refrigeración Interior : B.S. 27°C (80°F) B.H. 19,0 °C (66°F) Exterior : B.S. 35°C (95°F) B.H. 24°C (75°F)

Longitud de la cañería refrigerante (un sentido) : 5m (16 pie)

2. Rango de operación garantizado

3. Tensión garantizada
198-264V, 50Hz : Monofásico
342-457V, 50Hz : Trifásico

4. La información de arriba está basada en la tensión indicada
Unidad interior Monofásico 230V 50Hz
Unidad exterior Monofásico 230V 50Hz /
trifásico 400V 50Hz

* Si se instala la guía de aire protegido opcional. B.S. -15°C

Refrigeración	Interior		Exterior
	Lím. Superior	B.S. 35°C B.H. 22,5°C	B.S. 46°C
Lím. Inferior	B.S. 19°C B.H. 15°C	B.S. -5°C *	

Nombre del Modelo	Unidad Interior		PKA-RP71FAL		PKA-RP100FAL	
	Unidad Exterior		PU-P71VHA	PU-P71YHA	PU-P100VHA	PU-P100YHA
Refrigeración	Capacidad	Btu/h	27.000		33.400	
		kW	7,9		9,8	
	Consumo Total		2,84		3,50	
	EER		2,78		2,80	
	Clase de etiqueta de energía		D		D	
	SHF		0,77		0,77	
Calefacción	Capacidad	Btu/h	-		-	
		kW	-		-	
	Consumo Total		-		-	
	COP		-		-	
	Clase de etiqueta de energía		-		-	
	Calefactor impulsor		-		-	
Alimentación	Fase	Ø	1	3	1	3
	Frecuencia	Hz	50	50	50	50
	Tensión	V	230	400	230	400
	Llave térmica	A	32	16	32	16
	Unidad Interior		Flujo de aire (Bajo-Alto)		Flujo de aire (Bajo-Alto)	
		m ³ /min	15-20		22-28	
		pie ³ /min	530-705		780-990	
		Presión externa	Pa		0	
		Nivel de ruido (Bajo-Alto)	dB(A)		39-45	
		Nivel de ruido (Bajo-Alto)	dB(A)		41-46	
		Terminación externa		Munsell 3,4Y 7,7/0,8		
		Dimensiones		An : mm		
				Pr : mm		
				Al : mm		
				An : pulgada		
				Pr : pulgada		
				Al : pulgada		
		Peso		kg		
				lbs		
		Cañería de drenaje de la unidad I.D.		mm		
				pulgada		
		Unidad Exterior		Flujo de aire		
				m ³ /min		
				pie ³ /min		
		Nivel de ruido en refrigeración		dB(A)		
		Nivel de ruido en calefacción		dB(A)		
		Terminación externa		Munsell Marfil 5Y 7/1		
		Dimensiones		An : mm		
				Pr : mm		
				Al : mm		
				An : pulgada		
				Pr : pulgada		
				Al : pulgada		
		Peso		kg		
				lbs		
		Tamaño de la cañería de refrigerante		Lado Gas O.D.		
				mm		
				pulgada		
				Lado Líquido O.D.		
				mm		
				pulgada		
		Longitud de la cañería de refrigerante		Diferencia de altura		
				m		
				Longitud		
				m		

NOTA: 1. Condiciones de rango (ISO T1)
Refrigeración Interior : B.S. 27°C (80°F) B.H. 19,0 °C (66°F) Exterior : B.S. 35°C (95°F) B.H. 24°C (75°F)

Longitud de la cañería refrigerante (un sentido) : 5m (16 pie)

2. Rango de operación garantizado

3. Tensión garantizada

198-264V, 50Hz : Monofásico
342-457V, 50Hz : Trifásico

4. La información de arriba está basada en la tensión indicada

Unidad interior Monofásico 230V 50Hz
Unidad exterior Monofásico 230V 50Hz /
trifásico 400V 50Hz

* Si se instala la guía de aire protegido opcional. B.S. -15°C

		Interior	Exterior
Refrigeración	Lim. Superior	B.S. 35°C. B.H. 22,5°C	B.S. 46°C
	Lim. Inferior	B.S. 19°C. B.H. 15°C	B.S. -5°C *

5. TIPO DE SUELO VERTICAL

Nombre del Modelo	Unidad Interior		PSA-RP71GA		PSA-RP100GA		PSA-RP125GA	PSA-RP140GA
	Unidad Exterior		PUH-P71VHA	PUH-P71YHA	PUH-P100VHA	PUH-P100YHA	PUH-P125YHA	PUH-P140YHA
Refrigeración	Capacidad	Btu/h	25.900		34.100		42.000	47.800
		kW	7,6		10,0		12,3	14,0
	Consumo Total	kW	2,88		3,66		4,54	5,53
	EER		2,64		2,73		2,71	2,53
	Clase de etiqueta de energía			D		D		D
Calefacción	Capacidad	Btu/h	30.700 [37.300]		39.200 [47.700]		48.800 [58.200]	58.000 [67.400]
		kW	9,0 [10,93]		11,5 [13,98]		14,3 [17,06]	17,0 [19,76]
	Consumo Total	kW	2,85 [4,78]		3,42 [5,90]		4,41 [7,17]	5,47 [8,23]
	COP		3,16		3,36		3,24	3,11
	Clase de etiqueta de energía			D		C		C
Alimentación	Calefactor impulsor	kW	[2,1]		[2,7]		[3,0]	[3,0]
	Fase	∅	1	3	1	3	3	3
	Frecuencia	Hz	50		50		50	50
	Tensión	V	230	400	230	400	400	
	Llave térmica	A	32	16	32	16	25	
Unidad Interior	Flujo de aire (Bajo-Alto)	m ³ /min	15-18		24-31		26-33	27-35
		pie ³ /min	530-635		850-1060		920-1165	955-1240
	Presión externa	Pa	0					
	Nivel de ruido (Bajo-Alto)	dB(A)	40-45		44-49		46-51	47-52
	Terminación externa		Munsell Blanco 0,70Y 8,59/0,97					
	Dimensiones	An : mm	600		600		600	
		Pr : mm	270		350		350	
		Al : mm	1900		1900		1900	
		An : pulgada	23-5/8		23-5/8		23-5/8	
		Pr : pulgada	10-5/8		13-3/4		13-3/4	
		Al : pulgada	74-13/16		74-13/16		74-13/16	
	Peso	kg	43 [45]		51 [53]		51 [53]	53 [55]
lbs		95 [99]		112 [117]		112 [117]	117 [121]	
Cañería de drenaje de la unidad I.D.	mm	20		20		20		
	pulgada	13/16		13/16		13/16		
Unidad Exterior	Flujo de aire	m ³ /min	55		65		100	
		pie ³ /min	1.940		2.290		3.530	
	Nivel de ruido en refrigeración	dB(A)	49		50		50	51
	Nivel de ruido en calefacción	dB(A)	50		52		52	53
	Terminación externa		Munsell Marfil 5Y 7/1					
Dimensiones	An : mm	950		950		950		
	Pr : mm	330+30		330+30		330+30		
	Al : mm	943		943		1350		
	An : pulgada	37-3/8		37-3/8		37-3/8		
	Pr : pulgada	13 + 1-3/16		13 + 1-3/16		13 + 1-3/16		
	Al : pulgada	37-1/8		37-1/8		53-1/8		
Peso	kg	93		94		131		
	lbs	205		207		289		
Tamaño de la cañería de refrigerante	Lado Gas O.D.	mm	15,88		15,88		15,88	
		pulgada	5/8		5/8		5/8	
	Lado Líquido O.D.	mm	9,52		9,52		9,52	
		pulgada	3/8		3/8		3/8	
Longitud de la cañería de refrigerante	Diferencia de altura	m	Máx. 50		Máx. 50		Máx. 50	
	Longitud	m	Máx. 50		Máx. 50		Máx. 50	

NOTA: 1. Condiciones de rango (ISO T1)

Refrigeración Interior : B.S. 27°C (80°F) B.H. 19,0 °C (66°F) Exterior : B.S. 35°C (95°F) B.H. 24°C (75°F)

- Longitud de la cañería refrigerante (un sentido) : 5m (16 pie)
2. Rango de operación garantizado

3. Tensión garantizada

198-264V, 50Hz : Monofásico
342-457V, 50Hz : Trifásico

4. La información de arriba está basada en la tensión indicada

Unidad interior Monofásico 230V 50Hz
Unidad exterior Monofásico 230V 50Hz /
trifásico 400V 50Hz

- * Si se instala la guía de aire protegido opcional. B.S. -15°C

Refrigeración	Interior		Exterior
	Lim. Superior	B.S. 35°C. B.H. 22,5°C	B.S. 46°C
	Lim. Inferior	B.S. 19°C. B.H. 15°C	B.S. -5°C

Nombre del Modelo	Unidad Interior		PSA-RP71GA		PSA-RP100GA		PSA-RP125GA	PSA-RP140GA
	Unidad Exterior		PU-P71VHA	PU-P71YHA	PU-P100VHA	PU-P100YHA	PU-P125YHA	PU-P140YHA
Refrigeración	Capacidad	Bluh	25.900		34.100		42.000	47.800
		kW	7.6		10.0		12.3	14.0
	Consumo Total	kW	2.88		3.66		4.54	5.53
	EER		2.64		2.73		2.71	2.53
	Clase de etiqueta de energía		D		D		D	E
Calefacción	Capacidad	Bluh	0.73		0.81		0.75	0.74
		kW	-		-		-	-
	Consumo Total	kW	-		-		-	-
	COP		-		-		-	-
	Clase de etiqueta de energía		-		-		-	-
Alimentación	Calefactor impulsor	kW	-		-		-	-
	Fase	Ø	1	3	1	3	3	3
	Frecuencia	Hz	50		50		50	50
	Tensión	V	230	400	230	400	400	
	Llave térmica	A	32	16	32	16	25	
Unidad Interior	Flujo de aire (Bajo-Alto)	m ³ /min	15-18		24-31		26-33	27-35
		pie ³ /min	530-635		850-1060		920-1165	955-1240
	Presión externa	Pa	-		0		-	-
	Nivel de ruido (Bajo-Alto)	dB(A)	40-45		44-49		46-51	47-52
		Terminación externa	Munsell Blanco 0.70Y 8.59/0.97		Munsell Blanco 0.70Y 8.59/0.97		Munsell Blanco 0.70Y 8.59/0.97	
	Dimensiones	An : mm	600		600		600	
		Pr : mm	270		350		350	
		Al : mm	1900		1900		1900	
		An : pulgada	23-5/8		23-5/8		23-5/8	
		Pr : pulgada	10-5/8		13-3/4		13-3/4	
		Al : pulgada	74-13/16		74-13/16		74-13/16	
	Peso	kg	43		51		51	53
		lbs	95		112		112	117
	Cañería de drenaje de la unidad I.D.	mm	20		20		20	
		pulgada	13/16		13/16		13/16	
Flujo de aire		m ³ /min	55		65		100	
Nivel de ruido en calefacción	pie ³ /min	1.940		2.290		3.530		
	dB(A)	49		50		50	51	
Unidad Exterior	Nivel de ruido en calefacción	dB(A)	-		-		-	-
		Terminación externa	Munsell Marfil 5Y 7/1					
	Dimensiones	An : mm	950		950		950	
		Pr : mm	330+30		330+30		330+30	
		Al : mm	943		943		1350	
		An : pulgada	37-3/8		37-3/8		37-3/8	
		Pr : pulgada	13 + 1-3/16		13 + 1-3/16		13 + 1-3/16	
		Al : pulgada	37-1/8		37-1/8		53-1/8	
	Peso	kg	93		94		131	
		lbs	205		207		289	
	Tamaño de la cañería de refrigerante	Lado Gas O.D.	mm	15.88		15.88		15.88
			pulgada	5/8		5/8		5/8
		Lado Líquido O.D.	mm	9.52		9.52		9.52
			pulgada	3/8		3/8		3/8
	Longitud de la cañería de refrigerante	Diferencia de altura	m	Máx. 50		Máx. 50		Máx. 50
Longitud		m	Máx. 50		Máx. 50		Máx. 50	

NOTA: 1. Condiciones de rango (ISO T1)
Refrigeración Interior : B.S. 27°C (80°F) B.H. 19,0 °C (66°F) Exterior : B.S. 35°C (95°F) B.H. 24°C (75°F)

Longitud de la cañería refrigerante (un sentido) : 5m (16 pie)
2. Rango de operación garantizado

		Interior	Exterior
		Refrigeración	Lim. Superior B.S. 35°C B.H. 22.5°C Lim. Inferior B.S. 19°C B.H. 15°C

3. Tensión garantizada
198-264V, 50Hz : Monofásico
342-457V, 50Hz : Trifásico
4. La información de arriba está basada en la tensión indicada
Unidad interior Monofásico 230V 50Hz
Unidad exterior Monofásico 230V 50Hz /
Trifásico 400V 50Hz
- * Si se instala la guía de aire protegido opcional. B.S. -15°C

UNIDAD INTERIOR

PLA-RP35AA PLA-RP50AA
PLA-RP100AA2 PLA-RP125AA2

PLA-RP60AA PLA-RP71AA
PLA-RP140AA2

Unidad : mm

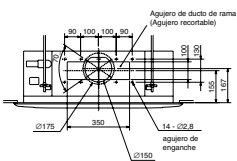

Dibujo detallado de la entrada de aire fresco

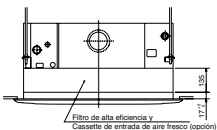

A (PANEL INALÁMBRICO)

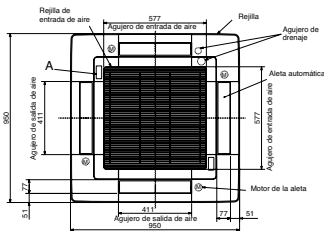
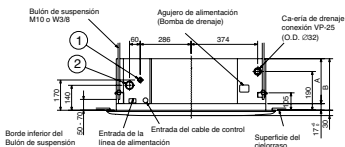
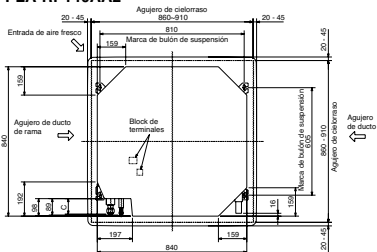
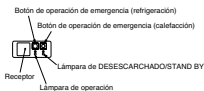

Use las tuercas actuales que coincidan con el tamaño de la cañería de la unidad exterior.
Tamaños disponibles de cañería

	RP35, 50	RP60	RP71	RP100, 125, 140	P35,50,60,71	P100, 125, 140
1 LADO LÍQUIDO	$\varnothing 6,35$ ○	$\varnothing 6,35$	-	-	-	-
	$\varnothing 9,52$	$\varnothing 9,52$ ○	$\varnothing 9,52$ ○	$\varnothing 9,52$ ○	$\varnothing 9,52$ ○	$\varnothing 9,52$ ○
	$\varnothing 12,7$ ○	-	-	-	-	-
2 LADO GAS	$\varnothing 15,88$	$\varnothing 15,88$ ○	$\varnothing 15,88$ ○	$\varnothing 15,88$ ○	$\varnothing 15,88$ ○	-
	-	-	-	$\varnothing 19,05$	-	$\varnothing 19,05$ ○
	-	-	-	-	-	-

○ Tuerca abocardada de fábrica adjunta al intercambiador de calor

Modelos	A	B	C
PLA-RP35,50AA PLA-RP60,71AA	241	258	80
PLA-RP100,125,140AA2	281	298	84

		PMH-P25BA	PMH-P35BA PMH-P50BA
Cañería refrigerante	Tapón de cañería	O.D. Ø35	
	Cañería de líquido	O.D. Ø6,35(1/4")	O.D. Ø9,52(3/8")
	Cañería de gas	O.D. Ø12,7(1/2")	O.D. Ø15,88(5/8")
Cañería de drenaje		Cañería PVC-VP-20(O.D. Ø25(1"))	

Detalles del agujero de entrada de aire fresco

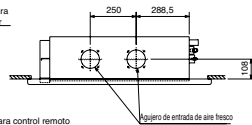
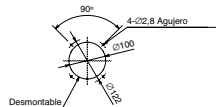

Espacio de instalación requerido alrededor de la unidad interior

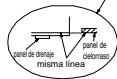
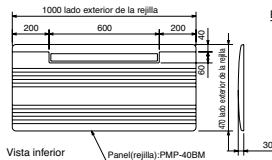
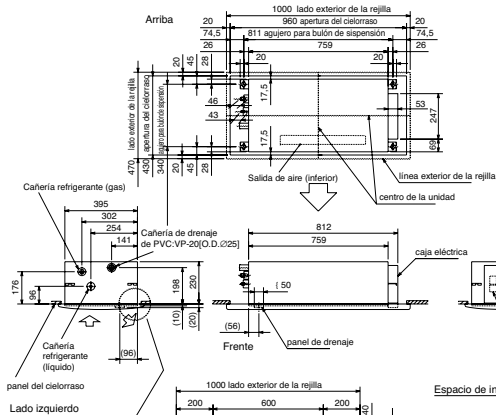
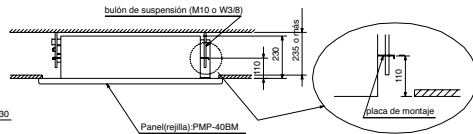

Unidad : mm

PEAD-RP35E2 PEAD-RP50EA PEAD-RP60EA

Modelo	A	B	C	D	E	F	G
RP35,50	772	305	-	830	804	Unidad exterior R410A: 6,35 * Unidad exterior R407C: 9,52	Unidad exterior R410A: 12,7 * Unidad exterior R407C: 15,88
RP60	1012	280	290	1070	1044	Unidad exterior[SUZ]: 8,36 Unidad exterior R407C: 9,52 *	15,88

* Configurado de fábrica

- 1 Conexión abocadada de cañería de refrigerante (tubo de cobre para líquido (LF)/AP
- 2 Conexión abocadada de cañería de refrigerante (tubo de cobre para gas (G)/BP
- 3 Drenaje R1 (Tramado externo)
- 4 Caja de partes eléctricas
- 5 Bomba de drenaje (Opción)
- 6 Cañería de drenaje (Opción)... Junta flexible VP-25 (I.D.032)
- 7 Filtro

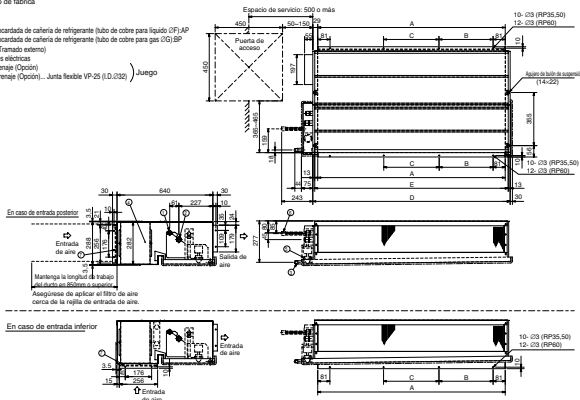

PEAD-RP71EA PEAD-RP100EA2 PEAD-RP125EA PEAD-RP140EA

Modelo	A	B	C	D	E	F
RP71	1012	280	290	1070	1044	15,88
RP100	1252	360	370	1310	1284	Unidad exterior R410A: 15,88 * Unidad exterior R407C: 19,05
RP140	1552	460	470	1610	1584	Unidad exterior R407C: 19,05

Configurado de fábrica

- 1 Conexión abocadada de cañería de refrigerante (tubo de cobre para líquido (L)/S);AP
- 2 Conexión abocadada de cañería de refrigerante (tubo de cobre para gas (G)/BP
- 3 Drenaje R1 (Tramado externo)
- 4 Caja de partes eléctricas
- 5 Bomba de drenaje (Opción)
- 6 Cañería de drenaje (Opción)... Junta flexible VP-25 (I.D.032)
- 7 Filtro

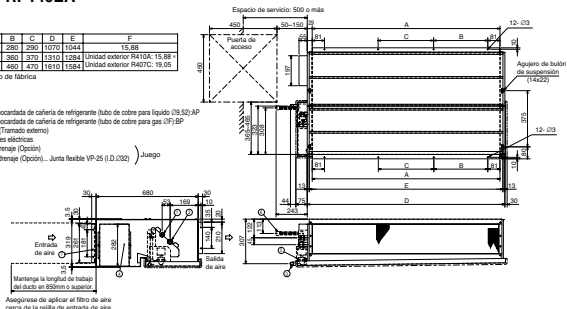

PEAD-RP60GA
PEAD-RP71GA
PEAD-RP100GA

Unit : mm

- 1 Cañería de refrigerante conexión abocardada (tubo de cobre para líquido (LH):AP
- 2 Cañería de refrigerante conexión abocardada (tubo de cobre para gas (GJ):BP
- 3 Caja de partes eléctricas
- 4 Bloque de terminales : Alimentación
- 5 Bloque de terminales : Control remoto
- 6 Filtro
- 7 Panel de drenaje (R1 Tramado externo: (234) (*, Fijable al lado opuesto).

Modelo	A	B	C	D	E	F	G	H	J
RP60	1125	1090	1050	1012	7	840	8	Unidad exterior(SUZ): 6,35 Otra unidad exterior: 9,52	15,88
RP71	1125	1090	1050	1012	7	840	8	9,52	15,88
RP100	1365	1330	1290	1252	9	1080	10	9,52	Unidad exterior R410A: 15,88 Unidad exterior R407C: 19,05

Configuración de fábrica

NOTA: ES NECESARIO REMOVER LAS PARTES DEL CIELO/RASO O MANTENER EL AGUJERO DE MANTENIMIENTO DE ARRIBA DE LA UNIDAD CUANDO DEBE MANTENER O REPARAR LAS SIGUIENTES PARTES:
 MOTOR, VENTILADOR SIROCCO, INTERCAMBIADOR DE CALOR, PANEL DE DRENAJE
 SERVICIO: FILTRO (EN CASO QUE LA UNIDAD INTERIOR TENGA UN DUCTO DE ENTRADA).
 MANTENIMIENTO: INTERCAMBIADOR DE CALOR, PANEL DE DRENAJE (LIMPIEZA DE SUPERFICIE) (LAVADO) FILTRO (EN CASO QUE LA UNIDAD INTERIOR TENGA UN DUCTO DE ENTRADA).

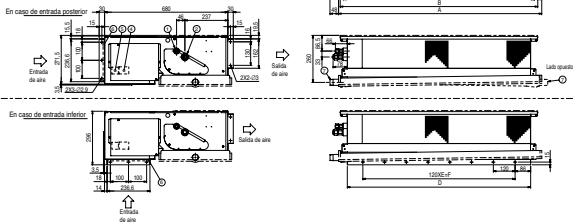

Modelo	A	B	C	D	E	F	G	H	J
RP60	1125	1090	1050	1012	7	840	8	Unidad exterior(SUZ): 6,35 Otra unidad exterior: 9,52 *	15,88
RP71	1125	1090	1050	1012	7	840	8	9,52	15,88
RP100	1365	1330	1290	1252	9	1080	10	9,52	Unidad exterior R410A: 15,88 * Unidad exterior R407C: 19,05

* Configurado de fábrica

PKA-RP35GAL
PKA-RP50GAL

Unidad : mm

Mr.SLM

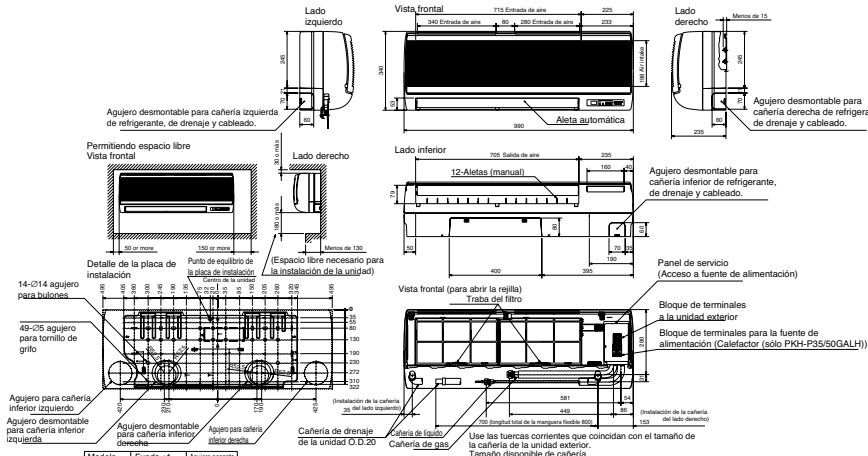

Modelo	Funda +1	Agujero pasante
35,50	Ø90	Ø90-Ø100

*1 Las fundas están disponibles en el mercado.
*2 Esta medida muestra el extremo inferior del agujero pasante.

Use las tuercas corrientes que coincidan con el tamaño de la cañería de la unidad exterior.
Tamaño disponible de cañería

	RP35,50	P35,50
LADO LÍQUIDO	Ø6,35 ○	-
	Ø9,52	Ø9,52 ○
LADO GAS	Ø12,7 ○	-
	Ø15,88	Ø15,88 ○

○ : Tuerca abocardada provista de fábrica adjunta al intercambiador de calor.

PKA-RP60FAL
PKA-RP71FAL

Unidad : mm

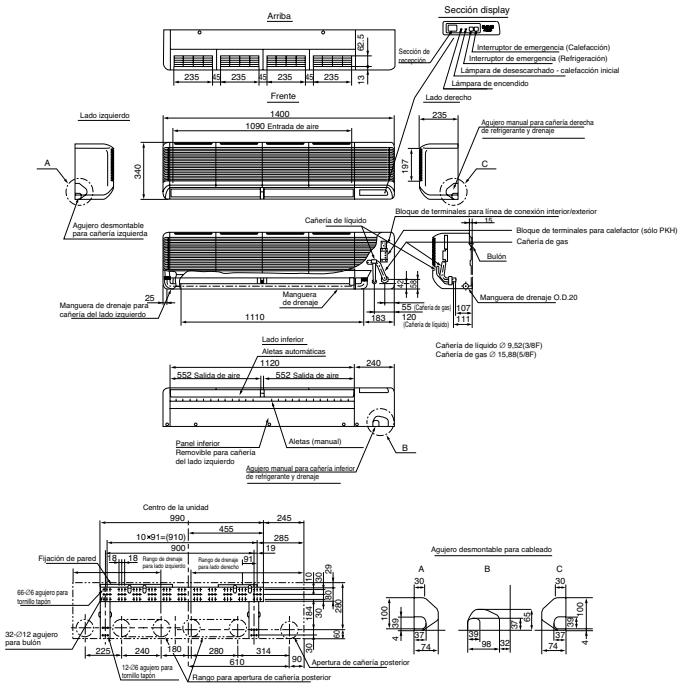

PCA-RP50GA

Unidad : mm

NOTAS:

1. Use tornillos M10 o W3/8 para bulón de anclaje.
2. Cuando se instala el mecanismo opcional de elevación de drenaje, siempre provea cañería de elevación para cañería de refrigerante.

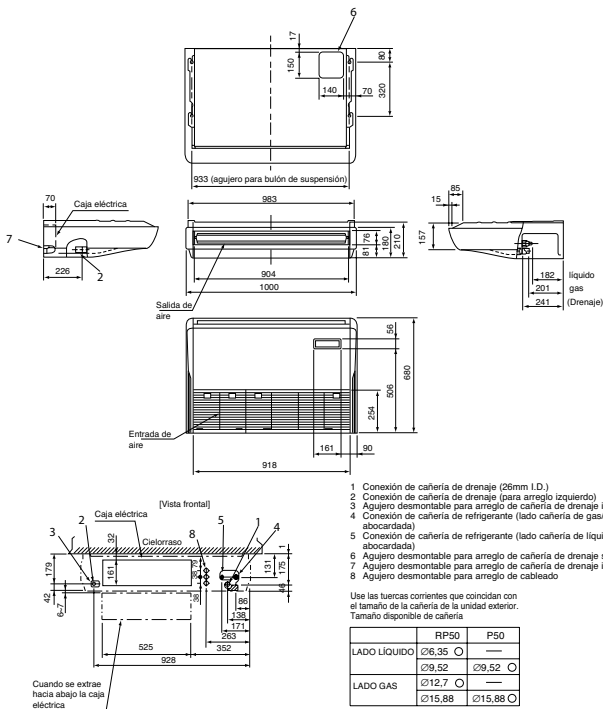

PCA-RP60GA
PCA-RP71GA

Unidad : mm

NOTAS:

1. Use tornillos M10 o W3/8 para bulón de anclaje.
2. Cuando se instala el mecanismo opcional de elevación de drenaje, siempre provea cañería de elevación para cañería de refrigerante.

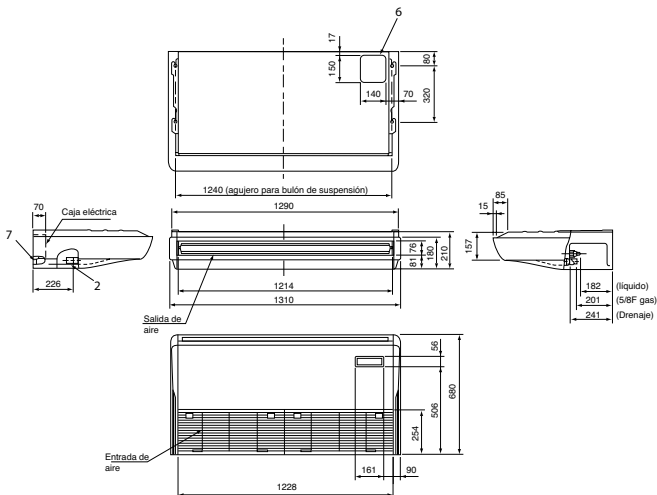

- 1 Conexión de cañería de drenaje (26mm I.D.)
- 2 Conexión de cañería de drenaje (para arreglo izquierdo)
- 3 Agujero desmontable para arreglo de cañería de drenaje izquierdo
- 4 Conexión de cañería de refrigerante (lado cañería de gas/conexión abocadada)
- 5 Conexión de cañería de refrigerante (lado cañería de liquido/conexión abocadada)
- 6 Agujero desmontable para arreglo de cañería de drenaje superior
- 7 Agujero desmontable para arreglo de cañería de drenaje izquierdo
- 8 Agujero desmontable para arreglo de cableado

Use las tuercas corrientes que coincidan con el tamaño de la cañería de la unidad exterior.
Tamaño disponible de cañería

	RP60	RP71, P60, P71
LADO LIQUIDO	∅6,35 ○	—
	∅9,52	∅9,52 ○
LADO GAS	—	—
	∅15,88	∅15,88 ○

○ : Tuerca abocadada provista de fábrica adjunta al intercambiador de calor.

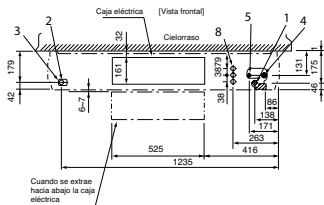

PCA-RP100GA

Unidad : mm

NOTAS:

1. Use tornillos M10 o W3/8 para bulón de anclaje.
2. Cuando se instala el mecanismo opcional de elevación de drenaje, siempre provea cañería de elevación para cañería de refrigerante.

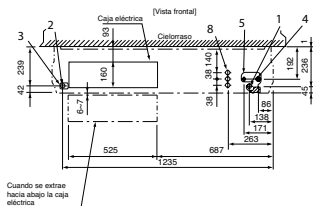
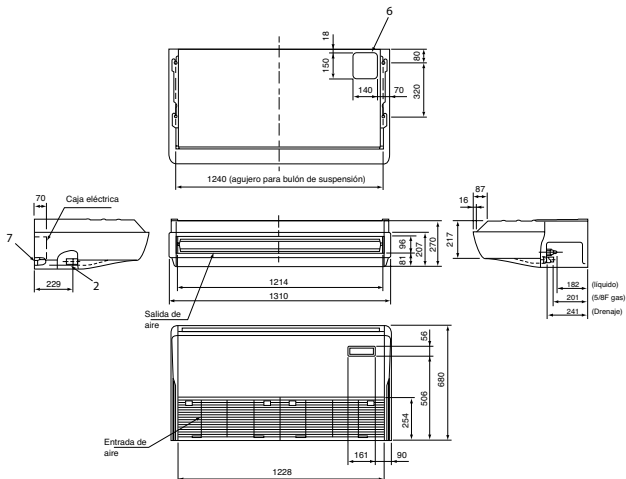

- 1 Conexión de cañería de drenaje (26mm I.D.)
- 2 Conexión de cañería de drenaje (para arreglo izquierdo)
- 3 Agujero desmontable para arreglo de cañería de drenaje izquierdo
- 4 Conexión de cañería de refrigerante (lado cañería de gas/conexión abocardada)
- 5 Conexión de cañería de refrigerante (lado cañería de líquido/conexión abocardada)
- 6 Agujero desmontable para arreglo de cañería de drenaje superior
- 7 Agujero desmontable para arreglo de cañería de drenaje izquierdo
- 8 Agujero desmontable para arreglo de cableado

Use las tuercas corrientes que coincidan con el tamaño de la cañería de la unidad exterior.
Tamaño disponible de cañería

	RP100	P100
LADO LÍQUIDO	-	-
	Ø9,52 ○	Ø9,52 ○
LADO GAS	-	-
	Ø15,88 ○	
	Ø19,05	Ø19,05 ○

○: Tuerca abocardada provista de fábrica adjunta al intercambiador de calor.

PCA-RP125GA
PCA-RP140GA

Unidad : mm

NOTAS:

1. Use tornillos M10 o W3/8 para bulón de anclaje.
2. Cuando se instala el mecanismo opcional de elevación de drenaje, siempre provea cañería de elevación para cañería de refrigerante.

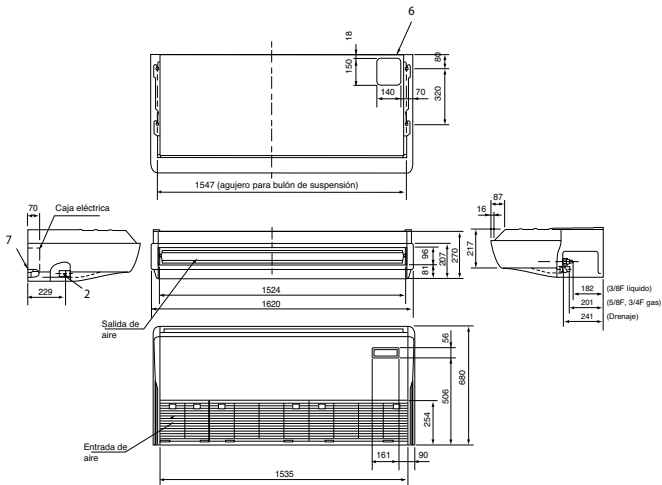

- 1 Conexión de cañería de drenaje (26mm I.D.)
- 2 Conexión de cañería de drenaje (para arreglo izquierdo)
- 3 Agujero desmontable para arreglo de cañería de drenaje izquierdo
- 4 Conexión de cañería de refrigerante (lado cañería de gas/conexión abocardada)
- 5 Conexión de cañería de refrigerante (lado cañería de líquido/conexión abocardada)
- 6 Agujero desmontable para arreglo de cañería de drenaje superior
- 7 Agujero desmontable para arreglo de cañería de drenaje izquierdo
- 8 Agujero desmontable para arreglo de cableado

Use las tuercas corrientes que coincidan con el tamaño de la cañería de la unidad exterior.
Tamaño disponible de cañería

	RP125,140	P125,140
5 LADO LÍQUIDO	—	—
4 LADO GAS	∅9,52 ○ ∅15,88 ○ ∅19,05	∅9,52 ○ ∅19,05

○: Tuerca abocardada provista de fábrica adjunta al intercambiador de calor.

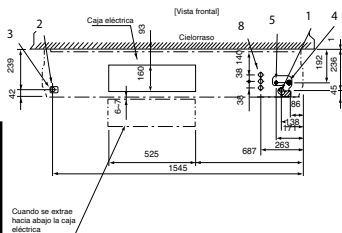

Cuando se extrae hacia abajo la caja eléctrica

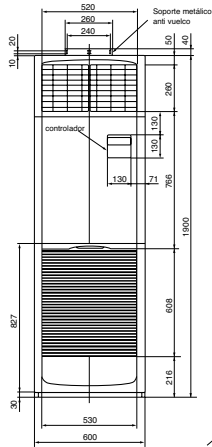
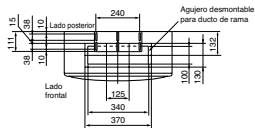

Agujero desmontable para refrigerante y drenaje.
90x60 oval (P+V) solo en ambos lados)

Agujero desmontable
para cableado.
∅27 (Provisto en ambos lados)

VISTA "A"

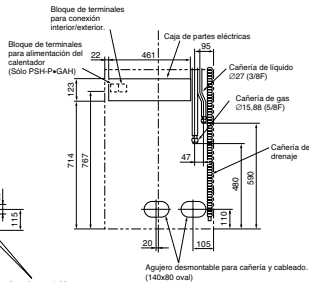
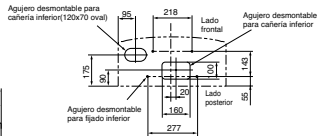

A

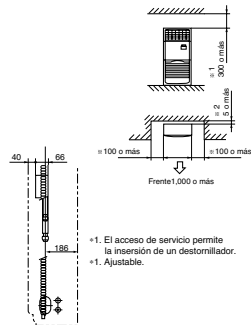

- El acceso de servicio permite la inserción de un destornillador.
- Ajustable.

PSA-RP100GA
PSA-RP125GA
PSA-RP140GA

Unidad: mm

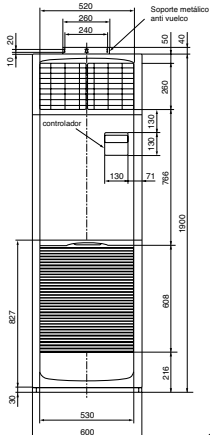
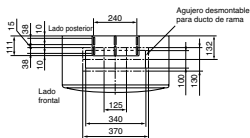

Agujero desmontable para refrigerante y drenaje.
 90x60 oval (Provisto en ambos lados)

Agujero desmontable para cableado.
 Ø27 (Provisto en ambos lados)

VISTA "A"

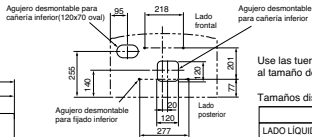

Use las tuercas corrientes correspondientes al tamaño de cañería de la unidad exterior.

Tamaños disponibles de cañería

	RP100,125,140	P100,125,140
LADO LÍQUIDO	Ø9,52 ○	Ø9,52 ○
LADO GAS	Ø15,88 ○ Ø19,05 ○	-

○ : De fábrica se adjunta la tuerca abocardada al intercambiador de calor

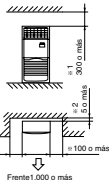

- 1. El acceso de servicio permite la inserción de un destornillador.
- 1. Ajustable.

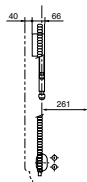
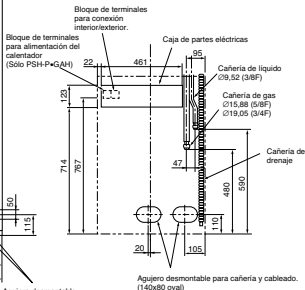

↑
A

CONTROL REMOTO CABLEADO

Unidad : mm

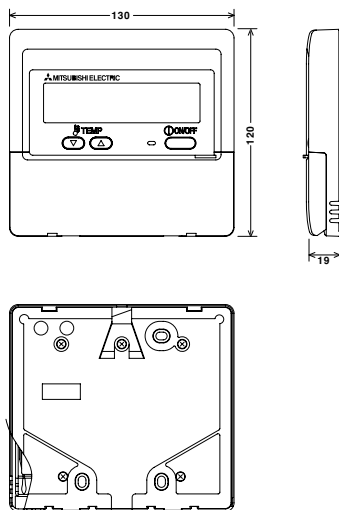

CONTROL REMOTO INALÁMBRICO

Unidad : mm

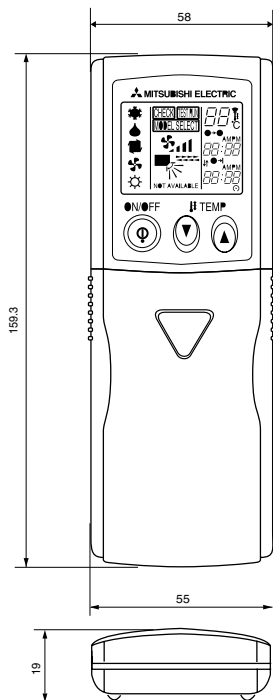

4-1. UNIDAD INTERIOR PLA-RP35AA PLA-RP50AA PLA-RP60AA PLA-RP71AA

[LEYENDA]

SÍMBOLO	NOMBRE	SÍMBOLO	NOMBRE	SÍMBOLO	NOMBRE
P.B	PLACA DE ALIMENTACIÓN INTERIOR	MF	MOTOR DEL VENTILADOR	W.B	PLACA DEL CONTROL REMOTO INALÁMBRICO
LB	PLACA CONTROLADORA INTERIOR	MV	MOTOR DE LA ALETA	RU	UNIDAD RECEPTORA
FUSIBLE	FUSIBLE(T6.3AL250V)	H2	CALEFACTOR DE PREVENCIÓN DE CONDENSADO	BZ	CHICHARRA
ZNR	VARIADOR	DP	BOMBA DE DRENAJE	LED1	LED(INDICADOR DE ENCENDIDO)
BCR	ELEMENTO DE CONTROL DEL VENTILADOR	DS	SENSOR DE DRENAJE	LED2	LED(AJUSTE EN CALIENTE)
CN2L	CONECTOR (LOSSNAI)	TB2	BLOQUE DE TERMINALES (CALEFACTOR) ^{*)}	SW1	INTERRUPTOR(CALEFACCIÓN ON/OFF)
CN32	CONECTOR (INTERRUPTOR REMOTO)	Modelos PLH-P. AAH	Unidad para modelos PLA-RP. AA	SW2	INTERRUPTOR(REFRIGERACIÓN ON/OFF)
CN41	CONECTOR (HA TERMINAL-A)	TB4	BLOQUE DE TERMINALES (LINEA DE CONEXIÓN INTERIOR/EXTERIOR)	HEATER	
CN51	CONECTOR (CONTROL CENTRALIZADO)	TB5, TB6	BLOQUE DE TERMINALES (LINEA DE TRANSMISIÓN DEL CONTROL REMOTO)	FS1	FUSIBLE TÉRMICO (72°C/ 16A)
LED1	ALIMENTACIÓN (L.B)			FS2	FUSIBLE TÉRMICO (104°C/ 16A)
LED2	ALIMENTACIÓN (R.B)			H1	CALEFACTOR
LED3	TRANSMISIÓN (INTERIOR-EXTERIOR)	TH1	TERMISTOR DE TEMPERATURA AMBIENTE (DETECCIÓN 0°C/15kW, 25°C/5.4kW)	26H	INTERRUPTOR TÉRMICO DEL CALEFACTOR
X1	RELE(BOMBA DE DRENAJE)	TH2	TERMISTOR DE TEMPERATURA DE CÁMERA DE LÍQUIDO(DETECCIÓN 0°C/15kW, 25°C/5.4kW)	88H	CONTACTOR DEL CALEFACTOR
X4	RELAY(FAN MOTOR)	TH3	TERMISTOR DE TEMPERATURA DE CÁMERA DE EVAPORADO(DETECCIÓN 0°C/15kW, 25°C/5.4kW)		
SW1	INTERRUPTOR(SELECCIÓN DE MODELO) -Ver tabla 1				
SW2	INTERRUPTOR(CÓDIGO DE CAPACIDAD) -Ver tabla 2				
SWE	CONECTOR(OPERACIÓN DE EMERGENCIA)				
C	CAPACITOR(FAN MOTOR)	R.B	PLACA DEL CONTROL REMOTO CABLEADO		

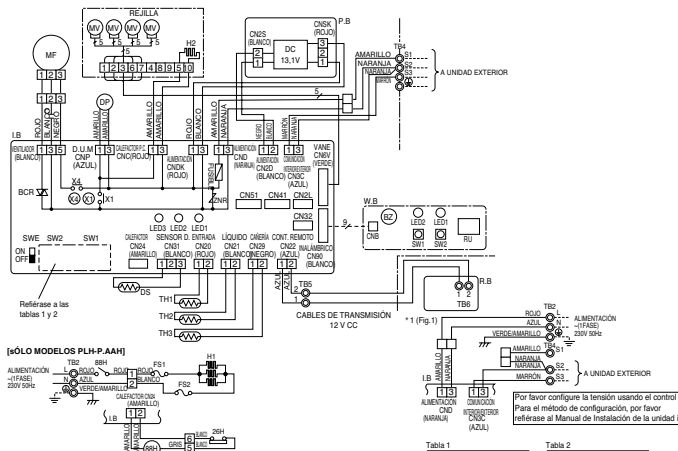

NOTAS:

- Los símbolos usados en el diagrama de cableado de arriba son, \square : Conector y \odot : Terminal (bloqueo).
- Los cables de conexión interior y exterior tienen polaridad, haga coincidir el cableado con los números de terminal (S1, S2 y S3).
- Dado que el cableado eléctrico del lado exterior puede cambiar, asegúrese de verificar el cableado eléctrico de la unidad exterior para servicio.
- Este diagrama muestra el cableado de los cables de conexión interior y exterior (especificación de 230V), adoptando un sistema superpuesto de alimentación y señal.
*1: Cuando se trabajó para proveer ALIMENTACIÓN en forma separada a la Unidad Interior y Exterior, referirse a la Fig. 1.
*2: Para sistemas de ALIMENTACIÓN de esta unidad, referirse a la etiqueta de precaución ubicada cerca del diagrama.

Tabla 1

MODELOS	SW1	Fábrica/Servicio
PLA-RP. AA	<input type="checkbox"/> ON <input type="checkbox"/> OFF	<input type="checkbox"/> ON <input type="checkbox"/> OFF
PLH-P. AAH	<input type="checkbox"/> ON <input type="checkbox"/> OFF	<input type="checkbox"/> ON <input type="checkbox"/> OFF

Tabla 2

MODELOS	SW2	Fábrica/Servicio
PLA-RP35AA	<input type="checkbox"/> ON <input type="checkbox"/> OFF	<input type="checkbox"/> ON <input type="checkbox"/> OFF
PLH-P35AAH	<input type="checkbox"/> ON <input type="checkbox"/> OFF	<input type="checkbox"/> ON <input type="checkbox"/> OFF
PLA-RP50AA	<input type="checkbox"/> ON <input type="checkbox"/> OFF	<input type="checkbox"/> ON <input type="checkbox"/> OFF
PLH-P50AAH	<input type="checkbox"/> ON <input type="checkbox"/> OFF	<input type="checkbox"/> ON <input type="checkbox"/> OFF
PLA-RP60AA	<input type="checkbox"/> ON <input type="checkbox"/> OFF	<input type="checkbox"/> ON <input type="checkbox"/> OFF
PLH-P60AAH	<input type="checkbox"/> ON <input type="checkbox"/> OFF	<input type="checkbox"/> ON <input type="checkbox"/> OFF
PLA-RP71AA	<input type="checkbox"/> ON <input type="checkbox"/> OFF	<input type="checkbox"/> ON <input type="checkbox"/> OFF
PLH-P71AAH	<input type="checkbox"/> ON <input type="checkbox"/> OFF	<input type="checkbox"/> ON <input type="checkbox"/> OFF

PLA-RP100AA2 PLA-RP125AA2 PLA-RP140AA2

[LEYENDA]

SÍMBOLO	NOMBRE	SÍMBOLO	NOMBRE	SÍMBOLO	NOMBRE
P.B	PLACA DE ALIMENTACIÓN INTERIOR	MV	MOTOR DE LA ALETA	W.B	PLACA DEL CONTROL REMOTO INALÁMBRICO
	FUSIBLE (T/SAL250V)	H2	CALEFACTOR DE PREVENCIÓN DE CONDENSADO	RU	UNIDAD RECEPTORA
	ZNR	DP	BOMBA DE DRENAJE	BZ	CHICHARRA
	IPM	DS	SENSOR DE DRENAJE	LED1	LED(INDICADOR DE ENCENDIDO)
LB	PLACA CONTROLADORA INTERIOR	TB2	LED2	LED(AJUSTE EN CALIENTE)	
	CN2L CONECTOR (LOSSNAY)	TB4	BLOQUE DE TERMINALES (LÍNEA DE CONEXIÓN INTERIOR/EXTERIOR)	SW1	INTERRUPTOR(CALEFACCIÓN ON/OFF)
	CN3Z CONECTOR (INTERRUPTOR REMOTO)			SW2	INTERRUPTOR(REFRIGERACIÓN ON/OFF)
	CN41 CONECTOR (HA TERMINAL-A)	TB5, TB6	BLOQUE DE TERMINALES (LÍNEA DE TRANSMISIÓN DEL CONTROL REMOTO)		
	CN51 CONECTOR (CONTROL CENTRALIZADO)				
	LED1 ALIMENTACIÓN (L.B)	DCL	REACTOR		
	LED2 ALIMENTACIÓN (R.B)	TH1	TERMISTOR DE TEMPERATURA AMBIENTE (DETECCIÓN 0°C/15kΩ, 25°C/5,4kΩ)		
	LED3 TRANSMISIÓN (INTERIOR-EXTERIOR)	TH2	TERMISTOR DE TEMPERATURA DE CAÑERÍA DE LÍQUIDO(DETECCIÓN 0°C/15kΩ, 25°C/5,4kΩ)		
	X1 RELÉ(BOMBA DE DRENAJE)	TH5	TERMISTOR DE TEMPERATURA DE CONDENSADO (EVAPORADO)(DETECCIÓN 0°C/15kΩ, 25°C/5,4kΩ)		
	SW1 INTERRUPTOR(SELECCIÓN DE MODELO) *Ver tabla 1				
	SW2 INTERRUPTOR(CÓDIGO DE CAPACIDAD) *Ver tabla 2				
	SWE CONECTOR(OPERACIÓN DE EMERGENCIA)				
MF	MOTOR DEL VENTILADOR	R.B	PLACA DEL CONTROL REMOTO CABLEADO		

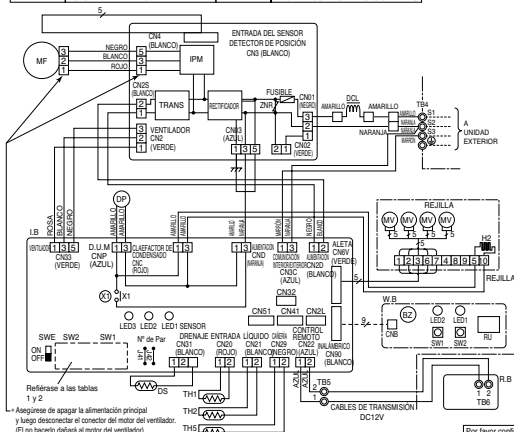

Referirse a las tablas 1 y 2

* Asegúrese de apagar la alimentación principal y luego desconectar el conector del motor del ventilador. (El no hacerlo dañará al motor del ventilador)

Por favor configure la tensión usando el control remoto. Para el método de configuración, por favor referirse al Manual de Instalación de la unidad interior.

- NOTAS: 1. Los símbolos usados en el diagrama de cableado de arriba son, □ : Conector y ○ : Terminal (bloque).
2. Los cables de conexión interior y exterior deben tener polaridad, haga coincidir el cableado con los números de terminal (S1, S2 y S3).
3. Dado que el cableado eléctrico del lado exterior puede cambiar, asegúrese de verificar el cableado eléctrico de la unidad exterior para servicio.
4. Este diagrama muestra el cableado de los cables de conexión interior y exterior (especificación de 230V), adoptando un sistema superpuesto de alimentación y señal.
- *1: Cuando se trabajó para proveer ALIMENTACIÓN en forma separada a la unidad Interior y Exterior, referirse a la Fig. 1.
- *2: Para sistemas de ALIMENTACIÓN de esta unidad, referirse a la etiqueta de precaución ubicada cerca del diagrama.

*1 (Fig.1)

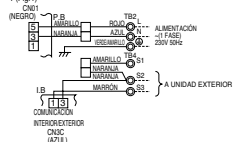

(Tabla 1) SW1 (SELECCIÓN DE MODELO)



(Tabla 2) SW2 (CÓDIGO DE CAPACIDAD)

MODELOS	Fábrica/Servicio	MODELOS	Fábrica/Servicio
PLA-RP100AA2		PLA-RP140AA2	
PLA-RP125AA2			

PMH-P25BA PMH-P35BA PMH-P50BA

[LEGENDA]

SÍMBOLO	NOMBRE
I.B	PLACA DE ALIMENTACIÓN INTERIOR
CN2L	CONECTOR (LOSSNAY)
CN32	CONECTOR (INTERRUPTOR REMOTO)
CN41	CONECTOR (HA TERMINAL-A)
FUSE	FUSIBLE(6,3A - 250V)
LED1	ALIMENTACIÓN (I.B)
LED2	ALIMENTACIÓN (R.B)
LED3	TRANSMISIÓN (INTERIOR-EXTERIOR)
SW1	PUENTE(SELECCIÓN DE MODELO)
SW2	PUENTE(CÓDIGO DE CAPACIDAD)
SWE	CONECTOR(OPERACIÓN DE EMERGENCIA)
T	TRANSFORMADOR
X1	RELÉ(BOMBA DE DRENAJE)
ZNR	VARISTOR
R.B	PLACA DEL CONTROL REMOTO CABLEADO
DP	BOMBA DE DRENAJE
DS	SENSOR DE DRENAJE
MF	MOTOR DEL VENTILADOR
MV	MOTOR DE LA ALETA
TB4	BLOQUE DE TERMINALES (LÍNEA DE CONEXIÓN INTERIOR/EXTERIOR)
TB5, TB6	BLOQUE DE TERMINALES (LÍNEA DE TRANSMISIÓN DEL CONTROL REMOTO)
TH1	TERMISTOR DE TEMPERATURA AMBIENTE (DETECCIÓN 0°C/19kW, 25°C/5,4kW)
TH2	TERMISTOR DE TEMPERATURA DE CÁMERA DE LÍQUIDO(DETECCIÓN 0°C/19kW, 25°C/5,4kW)
TH5	TERMISTOR DE TEMPERATURA DE CONDENSADOR/ EVAPORADO(DETECCIÓN 0°C/19kW, 25°C/5,4kW)

NOTAS:

- Dado que el cableado eléctrico del lado exterior puede cambiar, asegúrese de verificar el cableado eléctrico de la unidad exterior para servicio.
- Los cables de conexión interior y exterior tienen polaridad, haga coincidir el cableado con los números de terminal (S1, S2 y S3).
- Los símbolos usados en el diagrama de cableado de arriba son, □ □ □ : Conector y ⊙ : Terminal (bloque).

Por favor configure la tensión usando el control remoto. Para el método de configuración, por favor refiérase al Manual de Instalación de la unidad interior.

MODELOS	Fábrica	Placa de servicio
PMH-P25/35/50BA	J11 J12 J13 J14 J15	1 2 3 4 5 ON OFF
PMH-P25BA	01 02 03 04	1 2 3 4 ON OFF
PMH-P35BA	01 02 03 04	1 2 3 4 ON OFF
PMH-P50BA	01 02 03 04	1 2 3 4 ON OFF

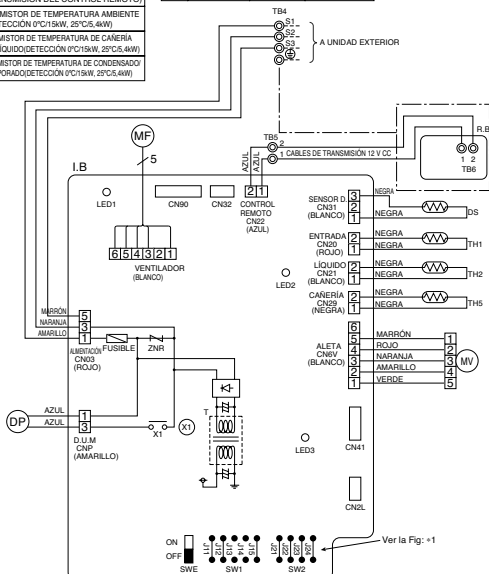

PEAD-RP35EA2 PEAD-RP50EA PEAD-RP60EA PEAD-RP71EA PEAD-RP100EA2 PEAD-RP125EA PEAD-RP140EA

SÍMBOLO	NOMBRE	SÍMBOLO	NOMBRE	SÍMBOLO	NOMBRE
I.B.	PLACA CONTROLADORA INTERIOR	SW2	INTERRUPTOR(CODIGO DE CAPACIDAD)	TB4	BLOQUE DE TERMINALES (LINEA DE CONEXIÓN INTERIOR/EXTERIOR)
FUSIBLE	FUSIBLE(T6.3AL250V)	SWE	INTERRUPTOR(OPERACIÓN DE EMERGENCIA)	TB5	BLOQUE DE TERMINALES (CONTROL REMOTO)
ZNR	VARISTOR	X1	RELÉ(BOMBA DE DRENAJE)	TH1	TERMISTOR DE TEMPERATURA DE ENTRADA DE AIRE(°C/15W, 25°C/5.4W)
CN2L	CONECTOR (LOSSNAY)	X4	RELE(MOTOR DEL VENTILADOR)	TH2	TERMISTOR DE TEMPERATURA DE CÁMERA DE LÍQUIDO(DETECCIÓN 0°C/15W, 25°C/5.4W)
CN24	CONECTOR(CALEFACTOR)	X5	RELE(MOTOR DEL VENTILADOR)	TH5	TERMISTOR DE TEMPERATURA DE CONDENSADO EVAPORADO(DETECCIÓN 0°C/15W, 25°C/5.4W)
CN32	CONECTOR (INTERRUPTOR REMOTO)	X8	RELE(MOTOR DEL VENTILADOR)		
CN41	CONECTOR (4A TERMINAL-A)	P.B.	PLACA DE ALIMENTACIÓN INTERIOR (Partes Opcionales)		
CN51	CONECTOR (CONTROL CENTRALIZADO)	DS	BOMBA DE DRENAJE		
CN90	CONECTOR(INALAMBÉRICO)	DS	SENSOR DE DRENAJE		
LED1	ALIMENTACIÓN (I.B)	C	CAPACITOR(MOTOR DEL VENTILADOR)		
LED2	ALIMENTACIÓN(CONTROL REMOTO)	MF	MOTOR DEL VENTILADOR		
LED3	TRANSMISIÓN (INTERIOR/EXTERIOR)				
SW1	INTERRUPTOR(SELECCIÓN DE MODELO)				

SECCIÓN INTERIOR DE LA CAJA DE CONTROL

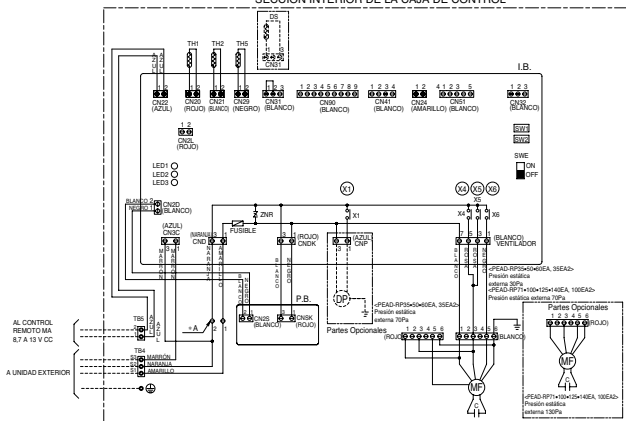

MODELOS	SW1	SW2
35EA(2)	1 2 3 4 5 6 7 8 9 10	1 2 3 4 5 6 7 8 9 10
50EA	1 2 3 4 5 6 7 8 9 10	1 2 3 4 5 6 7 8 9 10
60EA	1 2 3 4 5 6 7 8 9 10	1 2 3 4 5 6 7 8 9 10
71EA	1 2 3 4 5 6 7 8 9 10	1 2 3 4 5 6 7 8 9 10
100EA(2)	1 2 3 4 5 6 7 8 9 10	1 2 3 4 5 6 7 8 9 10
125EA	1 2 3 4 5 6 7 8 9 10	1 2 3 4 5 6 7 8 9 10
140EA	1 2 3 4 5 6 7 8 9 10	1 2 3 4 5 6 7 8 9 10

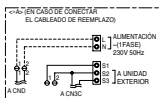

- NOTA
1. DADO QUE EL CABLEADO ELÉCTRICO DEL LADO EXTERIOR PUEDE CAMBIAR, ASEGÚRESE DE VERIFICAR EL CABLEADO ELÉCTRICO DE LA UNIDAD EXTERIOR PARA SERVICIO.
 2. LOS CABLES DE CONEXIÓN INTERIOR Y EXTERIOR TIENEN POLARIDAD, HAGA COINCIDIR EL CABLEADO CON LOS NÚMEROS DE TERMINAL (S1, S2 Y S3).
 3. LOS SÍMBOLOS USADOS EN EL DIAGRAMA DE CABLEADO DE ARRIBA SON, **□□□** : CONECTOR Y **○□○** : TERMINAL (BLOQUE).
 4. EL CABLEADO ENTRE EL CONTROL REMOTO MA Y TB5 SE INCLUYE EN EL CONJUNTO.

PEAD-RP60GA PEAD-RP71GA PEAD-RP100GA

SÍMBOLO	NOMBRE	SÍMBOLO	NOMBRE	SÍMBOLO	NOMBRE
I.B.	PLACA CONTROLADORA INTERIOR	SW1	INTERRUPTOR(SELECCIÓN DE MODELO)	TB5	BLOQUE DE TERMINALES (CONTROL REMOTO)
FUSE	FUSIBLE(T6.3AL250V)	SW2	INTERRUPTOR(CÓDIGO DE CAPACIDAD)	TH1	TERMISTOR DE TEMPERATURA DE ENTRADA DE AIRE (0°C/15kW, 25°C/5,4kW)
ZNR	VARISTOR	SWE	INTERRUPTOR(OPERACIÓN DE EMERGENCIA)	TH2	TERMISTOR DE TEMPERATURA DE CÁMERA DE LÍQUIDO/DETECCIÓN (0°C/15kW, 25°C/5,4kW)
CN2L	CONECTOR (LOSSNAY)	X1	RELE (BOMBA DE DRENAJE)	TH5	TERMISTOR DE TEMPERATURA DE CONDENSADO/ EVAPORADO/DETECCIÓN (0°C/15kW, 25°C/5,4kW)
CN24	CONECTOR(CALEFACTOR)	X4	RELE(MOTOR DEL VENTILADOR)		
CN32	CONECTOR (INTERRUPTOR REMOTO)	X5	RELE(MOTOR DEL VENTILADOR)		
CN41	CONECTOR (HA TERMINAL-A)	X6	RELE(MOTOR DEL VENTILADOR)		
CN51	CONECTOR (CONTROL CENTRALIZADO)	P.B.	PLACA DE ALIMENTACIÓN INTERIOR		
CN90	CONECTOR(INALAMBRICO)	C	CAPACITOR(MOTOR DEL VENTILADOR)		
LED1	ALIMENTACIÓN (I.B)		MOTOR DEL VENTILADOR		
LED2	ALIMENTACIÓN(CONTROL REMOTO)	TB4	TERMINAL BLOCK		
LED3	TRANSMISIÓN (INTERIOR-EXTERIOR)		(INDOOR/OUTDOOR CONNECTING LINE)		

SECCIÓN INTERIOR DE LA CAJA DE CONTROL

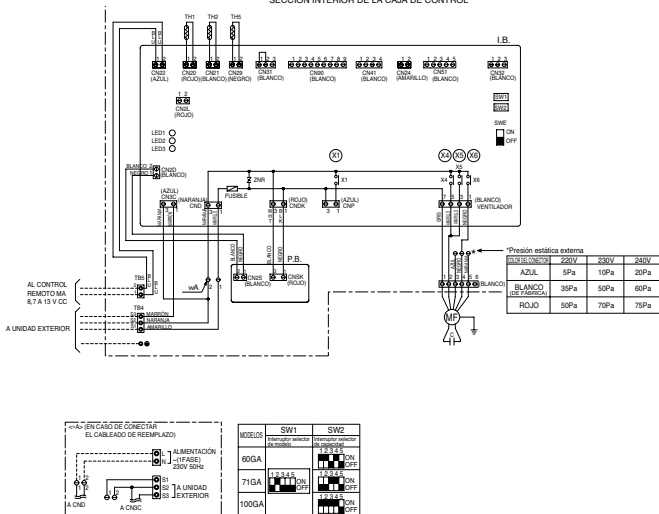

- NOTA 1. DADO QUE EL CABLEADO ELÉCTRICO DEL LADO EXTERIOR PUEDE CAMBIAR, ASEGÚRESE DE VERIFICAR EL CABLEADO ELÉCTRICO DE LA UNIDAD EXTERIOR PARA SERVICIO.
2. LOS CABLES DE CONEXIÓN INTERIOR Y EXTERIOR TIENEN POLARIDAD, HAGA COINCIDIR EL CABLEADO CON LOS NÚMEROS DE TERMINAL (S1, S2 Y S3).
3. LOS SÍMBOLOS USADOS EN EL DIAGRAMA DE CABLEADO DE ARRIBA SON, : CONECTOR Y : TERMINAL (BLOQUE).
4. EL CABLEADO ENTRE EL CONTROL REMOTO MA Y TB5 SE INCLUYE EN EL CONJUNTO.

PEAD-RP60GA PEAD-RP71GA PEAD-RP100GA

SÍMBOLO	NOMBRE	SÍMBOLO	NOMBRE	SÍMBOLO	NOMBRE
I.B.	PLACA CONTROLADORA INTERIOR	SW1	INTERRUPTOR(SELECCIÓN DE MODELO)	TB5	BLOQUE DE TERMINALES (CONTROL REMOTO)
FUSE	FUSIBLE(Tb.3AL 250V)	SW2	INTERRUPTOR(CODIGO DE CAPACIDAD)	TH1	TERMISTOR DE TEMPERATURA DE ENTRADA DE AIRE (°C)19AW, 25°C(S.4W)
ZNR	VARISTOR	SWE	INTERRUPTOR(OPERACIÓN DE EMERGENCIA)	TH2	TERMISTOR DE TEMPERATURA DE CÁMERA DE LÍQUIDO(TECCIÓN)°C)19AW, 25°C(S.4W)
CN2L	CONECTOR (LOSSNAY)	X1	RELÉ(BOBINA DE DRENAJE)	TH5	TERMISTOR DE TEMPERATURA DE CONDENSADO/ EVAPORADO(TECCIÓN)°C)19AW, 25°C(S.4W)
CN24	CONECTOR(CALEFACTOR)	X4	RELÉ(MOTOR DEL VENTILADOR)		
CN32	CONECTOR (INTERRUPTOR REMOTO)	X5	RELÉ(MOTOR DEL VENTILADOR)		
CN41	CONECTOR (HA TERMINAL-A)	X6	RELÉ(MOTOR DEL VENTILADOR)		
CN51	CONECTOR (CONTROL CENTRALIZADO)	P.B.	PLACA DE ALIMENTACIÓN INTERIOR		
CN50	CONECTOR(INALAMBÉRICO)	C	CAPACITOR(MOTOR DEL VENTILADOR)		
LED1	ALIMENTACIÓN (S)	M.F.	MOTOR DEL VENTILADOR		
LED2	ALIMENTACIÓN(CONTROL REMOTO)	TB4			
LED3	TRANSMISIÓN (INTERIOR-EXTERIOR)		(INDOOR/OUTDOOR CONNECTING LINE)		

SECCIÓN INTERIOR DE LA CAJA DE CONTROL

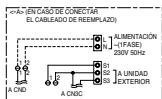
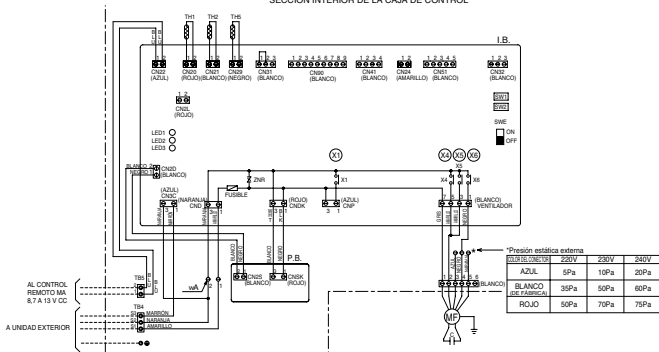

MODELO	SW1	SW2
60GA	Interruptor selector 2x250mA	Interruptor selector 2x250mA
71GA	1 2 3 4 5	1 2 3 4 5
100GA	1 2 3 4 5	1 2 3 4 5

- NOTA
- DADO QUE EL CABLEADO ELÉCTRICO DEL LADO EXTERIOR PUEDE CAMBIAR, ASEGÚRESE DE VERIFICAR EL CABLEADO ELÉCTRICO DE LA UNIDAD EXTERIOR PARA SERVICIO.
 - LOS CABLES DE CONEXIÓN INTERIOR Y EXTERIOR TIENEN POLARIDAD, HAGA COINCIDIR EL CABLEADO CON LOS NÚMEROS DE TERMINAL (S1, S2 Y S3).
 - LOS SÍMBOLOS USADOS EN EL DIAGRAMA DE CABLEADO DE ARRIBA SON, **□□□□** : CONECTOR Y **□□□□** : TERMINAL (BLOQUE).
 - EL CABLEADO ENTRE EL CONTROL REMOTO MA Y TB5 SE INCLUYE EN EL CONJUNTO.

PKA-RP60FAL PKA-RP71FAL PKA-RP100FAL

SÍMBOLO	NOMBRE	SÍMBOLO	NOMBRE	SÍMBOLO	NOMBRE
P.B	PLACA DE ALIMENTACIÓN INTERIOR	C	CAPACITOR (MOTOR DEL VENTILADOR)	W.B	PLACA DEL CONTROL REMOTO INALÁMBRICO
I.B	PLACA CONTROLADORA INTERIOR	MF	MOTOR DEL VENTILADOR	RU	UNIDAD RECEPTORA
FUSB1	FUSIBLE (6,3AL250V)	MV	MOTOR DE LA ALETA	BZ	CHICHAHARRA
ZNR	VARISTOR	Tb2	BLOQUE DE TERMINALES(CALEFACTOR *sólo modelos PKH-P.FALH y opción para modelos PKA-RP.FAL)	LED1	LED INDICADOR DE ENCENDIDO
CN2L	CONECTOR (LOSSNAY)	Tb4	BLOQUE DE TERMINALES (LÍNEA DE CONEXIÓN INTERIOR/EXTERIOR)	LED2	LED AJUSTE EN CALIENTE
CN32	CONECTOR (INTERRUPTOR REMOTO)	Tb5	BLOQUE DE TERMINALES (LÍNEA DE TRANSMISIÓN DEL CONTROL REMOTO)(OPCIÓN)	SW1	INTERRUPTOR/CALEFACCIÓN (ON/OFF)
CN41	CONECTOR (HA TERMINAL-A)	TH1	TERMISTOR DE TEMPERATURA AMBIENTE (DETECCIÓN 0°C/15s; 25°C/5.4s/1)	SW2	INTERRUPTOR/REFRIGERACIÓN (ON/OFF)
CN51	CONECTOR (CONTROL CENTRALIZADO)	TH2	TERMISTOR DE TEMPERATURA DE CANERÍA DE LÍQUIDO/DETECCIÓN 0°C/15s/1; 25°C/5.4s/1)	R.B	PLACA DEL CONTROL REMOTO CABLEADO(OPCIÓN)
SW1	INTERRUPTOR(SELECCIÓN DE MODELO) *Ver tabla 1	TH5	TERMISTOR DE TEMPERATURA DE CONDENSADO/ EVAPORADO/DETECCIÓN 0°C/15s/1; 25°C/5.4s/1)	Tb6	BLOQUE DE TERMINALES(LÍNEA DE TRANSMISIÓN DEL CONTROL REMOTO)
SW2	INTERRUPTOR(COORDINACIÓN DE CAPACIDAD) *Ver tabla 2			CALEFACTOR	
SWE	CONECTOR(OPERACIÓN DE EMERGENCIA)			FS1.2	FUSIBLE TÉRMICO (117°C: 10A.80, 71FALH; 117°C.16A.100FALH)
X4	RELE MOTOR DEL VENTILADOR			H1	CALEFACTOR
BCR	ELEMENTO CONTROLADOR DEL VENTILADOR			26H	INTERRUPTOR TERMICO DEL CALEFACTOR
LED1	ALIMENTACIÓN (I.B)			88H	CONTACTOR DEL CALEFACTOR
LED2	ALIMENTACIÓN (R.B)				
LED3	TRANSMISIÓN (INTERIOR-EXTERIOR)				



Tabla 1

SW1	Placa de servicio
1 2 3 4 5	ON OFF

Tabla 2

MODELOS	Placa de servicio	MODELOS	Placa de servicio	MODELOS	Placa de servicio
PKA-RP60FAL PKH-P60FALH	1 2 3 4 5 ON OFF	PKA-RP71FAL PKH-P71FALH	1 2 3 4 5 ON OFF	PKA-RP100FAL PKH-P100FALH	1 2 3 4 5 ON OFF

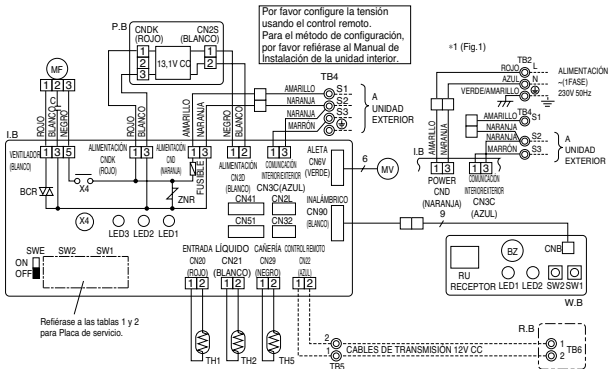
Sólo modelos PKH-P60, P100FALH

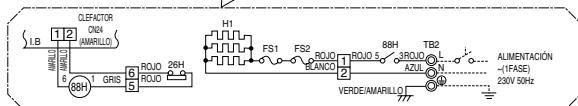

NOTAS:

- Dado que el cableado eléctrico del lado exterior puede cambiar, asegúrese de verificar el cableado eléctrico de la unidad exterior para servicio.
- Los cables de conexión interior y exterior tienen polaridad, haga coincidir el cableado con los números de terminal (S1, S2 y S3).
- Asegúrese de que el cable de alimentación principal del impulsor sea independiente.
- Los símbolos usados en el diagrama de cableado de arriba son, \square : Conector y \odot : Terminal (bloqueo).

*1: Cuando se trabajó para proveer ALIMENTACIÓN en forma separada a la unidad Interior y Exterior, refiérase a la Fig. 1.

*2: Para sistemas de ALIMENTACIÓN de esta unidad, refiérase a la etiqueta de precaución ubicada cerca del diagrama.

PCA-RP50GA PCA-RP60GA PCA-RP71GA PCA-RP100GA PCA-RP125GA PCA-RP140GA

SÍMBOLO	NOMBRE	SÍMBOLO	NOMBRE	SÍMBOLO	NOMBRE
P.B	PLACA DE ALIMENTACIÓN INTERIOR	MF	MOTOR DEL VENTILADOR	W.B	PLACA DEL CONTROL REMOTO INALÁMBRICO
IB	PLACA CONTROLADORA INTERIOR	MV	MOTOR DE LA ALETA	RV	UNIDAD RECEPTORA
FS1	FUSIBLE (16A,3AL/250V)	CM	CRAN/UP MACHINE (OPTION)	CH	CHICARRINA
ZNR	VARIABLE	DS	DRAIN SENSOR (OPTION)	LED1	LED/INDICADOR DE ENCENDIDO
CN2	CONECTOR (LOSS/NA)	TB2	BLOQUE DE TERMINALES/CALEFACTOR "solo modelos PCH-PGAH y opción para modelos PCA-RP-GA"	LED2	LED/AJUSTE EN CALIENTE
CN1	CONECTOR (INTERUPCIÓN REMOTO)	TB4	BLOQUE DE TERMINALES PARA CONEXIÓN EXTERIOR	SW1	INTERUPCIÓN/CALEFACCIÓN (ON/OFF)
CN1	CONECTOR PARA TERMINAL X1	TB5	BLOQUE DE TERMINALES DE CONEXIÓN EXTERIOR	SW2	INTERUPCIÓN/CALEFACCIÓN (ON/OFF)
CN1	CONECTOR CONTROL CENTRALIZADO	TB5, TB6	BLOQUE DE TERMINALES (LINEA DE TRANSMISIÓN DEL CONTROL REMOTO)	CALEFACTOR	
SW1	INTERUPCIÓN/SELECCIÓN DE MODELO "ver tabla 1"	TH1	TERMISTOR DE TEMPERATURA AMBIENTE (DETECCIÓN (°C)/15/31, 25/°C, 5/31)	FS1,2	FUSIBLE TERMICO (80°C: 10A,50GAH; 110°C: 16A,100GAH; 110°C: 16A/9,71,125,140GAH)
SW2	INTERUPCIÓN/SELECCIÓN DE CAPACIDAD "ver tabla 2"	TH2	TERMISTOR DE TEMPERATURA DE CAJERÍA (DETECCIÓN (°C)/19/44, 25/°C, 5/31)	HI	CALEFACTOR
SWE	CONECTOR/OPCIÓN DE EMERGENCIA	TH6	TERMISTOR DE TEMPERATURA DE CONDENSADOR (EVAPORADOR/DETECCIÓN (°C)/15/31, 25/°C, 5/31)	ZB	INTERUPCIÓN/TERMINO DEL CALEFACTOR
X1	RELE/BOMBA DE DRENAJE	R.B	PLACA DEL CONTROL REMOTO CABLEADO	8B	CONTACTOR DEL CALEFACTOR
X2	RELE/MOTOR DEL VENTILADOR				
BCR	ELEMENTO CONTROLADOR DEL VENTILADOR				
LED1	ALIMENTACIÓN (I.B)				
LED2	ALIMENTACIÓN (R.B)				
LED3	TRANSMISIÓN EXTERIOR (EXTERIOR)				
C	CAPACITOR (MOTOR DEL VENTILADOR)				



Tabla 2

Tabla 1	SW1	MODELOS	Placa de servicio	MODELOS	Placa de servicio
PCA-RP-GA PCH-PGAH		PCA-RP50GA PCH-P50GAH		PCA-RP100GA PCH-P100GAH	
PCA-RP60GA PCH-P60GAH		PCA-RP125GA PCH-P125GAH		PCA-RP140GA PCH-P140GAH	
PCA-RP71GA PCH-P71GAH					

NOTAS:

- Dado que el cableado eléctrico del lado exterior puede cambiar, asegúrese de verificar el cableado eléctrico de la unidad exterior para servicio.
- Los cables de conexión interior y exterior tienen polaridad, haga coincidir el cableado con los números de terminal (S1, S2 y S3).
- Asegúrese de que el cable de alimentación principal del impulsor principal sea independiente.
- Los símbolos usados en el diagrama de cableado de arriba son:
 Conector y Terminal (bloqueo).

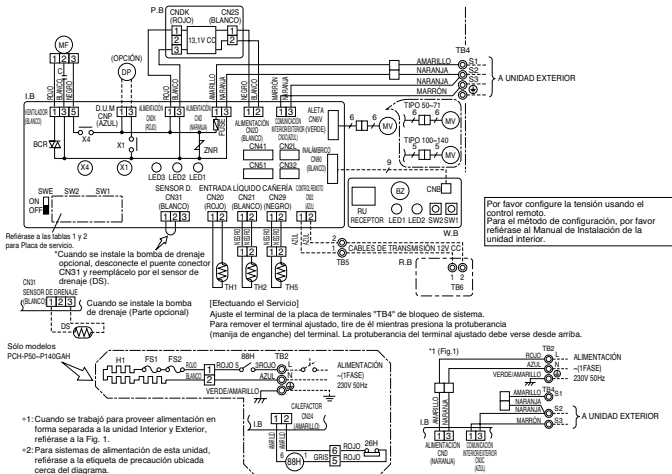
PCA-RP71HA PCA-RP125HA

[LEYENDA]

SÍMBOLO	NOMBRE	SÍMBOLO	NOMBRE
P. B	PLACA DE ALIMENTACIÓN INTERIOR	MF1, MF2	MOTOR DEL VENTILADOR
I. B	PLACA CONTROLADORA INTERIOR	C1, C2	CAPACITOR (MOTOR DEL VENTILADOR)
FUSIBLE	FUSIBLE(T6.3AL250V)	H2	CALEFACTOR DE PREVENCIÓN DE CONDENSADO
ZNR	VARISTOR	TB2	BLOQUE DE TERMINALES (ALIMENTACIÓN DE LA UNIDAD INTERIOR(OPCIÓN))
CN2L	CONECTOR (LOSSNAY)	TB4	BLOQUE DE TERMINALES (LÍNEA DE CONEXIÓN INTERIOR/EXTERIOR)
CN32	CONECTOR (INTERRUPTOR REMOTO)	TB5, TB6	BLOQUE DE TERMINALES (LÍNEA DE TRANSMISIÓN DEL CONTROL REMOTO)
CN41	CONECTOR (HA TERMINAL-A)	TH1	TERMISTOR DE TEMPERATURA AMBIENTE (DETECCIÓN 0°C/15kΩ, 25°C/5,4kΩ)
CN51	CONECTOR (CONTROL CENTRALIZADO)	TH2	TERMISTOR DE TEMPERATURA DE CAÑERÍA DE LÍQUIDO(DETECCIÓN 0°C/15kΩ, 25°C/5,4kΩ)
LED1	ALIMENTACIÓN (I.B)	TH5	TERMISTOR DE TEMPERATURA DE CONDENSADO/ EVAPORADO(DETECCIÓN 0°C/15kΩ, 25°C/5,4kΩ)
LED2	ALIMENTACIÓN (R.B)	R. B	PLACA DEL CONTROL REMOTO CABLEADO
LED3	TRANSMISIÓN (INTERIOR-EXTERIOR)		
X1	RELÉCALEFACTOR DE PREVENCIÓN DE CONDENSADO		
X4	RELÉ(MOTOR DEL VENTILADOR)		
X5	RELÉ(MOTOR DEL VENTILADOR)		
X6	RELÉ(MOTOR DEL VENTILADOR)		
SW1	INTERRUPTOR(SELECCIÓN DE MODELO) *Ver tabla 1.		
SW2	INTERRUPTOR(CODIGO DE CAPACIDAD) *Ver tabla 2.		
SWE	INTERRUPTOR(OPERACIÓN DE EMERGENCIA)		



Tabla 1

SW1					
Placa de servicio					
1	2	3	4	5	CN OFF

Tabla 2

SW2					
MODELOS	Placa de servicio	MODELOS	Placa de servicio		
PCA-RP71HA	1 2 3 4 5 ON OFF	PCA-RP125HA	1 2 3 4 5 ON OFF		

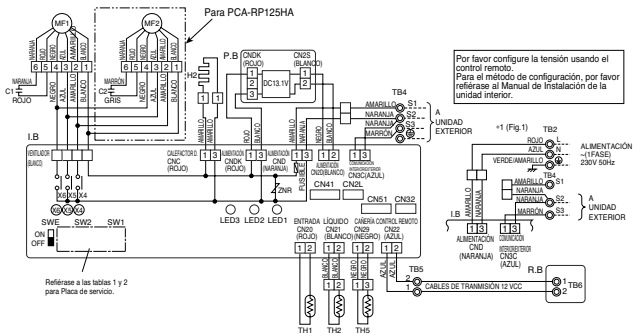
NOTAS:

- Dado que el cableado eléctrico del lado exterior puede cambiar, asegúrese de verificar el cableado eléctrico de la unidad exterior para servicio.
 - Los cables de conexión interior y exterior tienen polaridad, haga coincidir el cableado con los números de terminal (S1, S2 y S3).
 - Los símbolos usados en el diagrama de cableado de arriba son: : Conector y : Terminal (bloque).
- *1: Cuando se trabajó para proveer alimentación en forma separada a la unidad Interior y Exterior, refiérase a la Fig. 1.
*2: Para sistemas de alimentación de esta unidad, refiérase a la etiqueta de precaución ubicada cerca del diagrama.

PSA-RP71GA PSA-RP100GA PSA-RP125GA PSA-RP140GA

SÍMBOLO	NOMBRE	SÍMBOLO	NOMBRE	SÍMBOLO	NOMBRE
P.B	PLACA DE ALIMENTACIÓN INTERIOR	IB	SW1 INTERRUPTOR (SELECCIÓN DE MODO) -11v 16A 1	C	CAPACITOR MOTOR DEL VENTILADOR
CM1	PLACA CONTROLADORA INTERIOR	SW2	INTERRUPTOR (CÓDIGO DE CAPACIDAD) -11v 16A 2	MF	MOTOR DEL VENTILADOR
FUSE	FUSIBLE (T6.3A/250V)	SWE	INTERRUPTOR (OPERACIÓN DE EMERGENCIA)	ML	MOTOR DEL LOUVER
ZNR	VARIADOR	X2	RELÉ (LOUVER)	TB2	BLOQUE DE TERMINALES (CALEFACTOR) *solo modelos PSH-GAH u opción para modelos PSA-RP-GA
CN2L	CONECTOR (LOSSNAY)	X4	RELÉ (MOTOR DEL VENTILADOR)	TB4	BLOQUE DE TERMINALES (LÍNEA DE CONEXIÓN INTERIOR/EXTERIOR)
CN32	CONECTOR (MÁ TERMINAL-REMOTO)	X5	RELÉ (MOTOR DEL VENTILADOR)	TH1	TERMISTOR DE TEMPERATURA AMBIENTE (DETECCIÓN 0°C/15A/0, 25°C/5, 4A/0)
CN41	CONECTOR (MÁ TERMINAL-A)	X6	RELÉ (MOTOR DEL VENTILADOR)	TH2	TERMISTOR DE TEMPERATURA DE CANERÍA DE LÍQUIDO (DETECCIÓN 0°C/15A/0, 25°C/5, 4A/0)
CN5	CONECTOR (CONTROL CENTRALIZADO)	R.B	PLACA DEL CONTROL REMOTO CABLEADO	TH5	TERMISTOR DE TEMPERATURA DE CONDENSADO (EVAPORADO) (DETECCIÓN 0°C/15A/0, 25°C/5, 4A/0)
LED2	ALIMENTACIÓN (R.B)	CALEFACTOR			
LED3	TRANSMISIÓN (INTERIOR-EXTERIOR)	FS1,2	FUSIBLE TÉRMICO (110A/16A)		
		H	CALEFACTOR		
		2BH	INTERRUPTOR TÉRMICO DEL CALEFACTOR		
		BBH	CONTACTOR DEL CALEFACTOR		

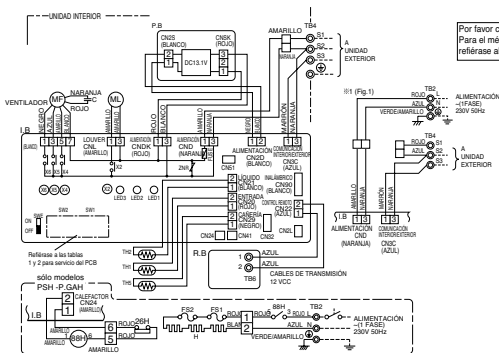

Por favor configure la tensión usando el control remoto.
Para el método de configuración, por favor refiérase al Manual de Instalación de la unidad interior.

Tabla 1

MODELOS	Placa de servicio
PSA-RP-GA PSH-P-GAH	

*1 : Cuando se trabajó para proveer ALIMENTACIÓN en forma separada a la unidad Interior y Exterior, refiérase a la Fig. 1.

*2 : Para sistemas de ALIMENTACIÓN de esta unidad, refiérase a la etiqueta de precaución ubicada cerca del diagrama.

Tabla 2

MODELOS	Placa de servicio
PSA-RP71GA PSH-P71GAH	
PSA-RP100GA PSH-P100GAH	
PSA-RP125GA PSH-P125GAH	
PSA-RP140GA PSH-P140GAH	

[NOTAS]

- Los símbolos usados en el diagrama de cableado de arriba son, : Conector y : Terminal (bloque).
- Los cables de conexión interior y exterior tienen polaridad, haga coincidir el cableado con los números de terminal (S1, S2 y S3).
- Dado que el cableado eléctrico del lado exterior puede cambiar, asegúrese de verificar el cableado eléctrico de la unidad exterior para servicio.
- Este diagrama muestra el cableado de los cables de conexión interior y exterior (especificación de 230V), adoptando un sistema superpuesto de alimentación y señal.

4-2. UNIDAD EXTERIOR

PUH-P71VHA PU-P71VHA PUH-P100VHA PU-P100VHA

SÍMBOLO	NOMBRE	SÍMBOLO	NOMBRE
MC	COMPRESOR (TERMOSTATO INTERNO)	FUSIBLE1(O.B)	FUSIBLE (6,3A 250V)
MF	MOTOR DEL VENTILADOR (TERMOSTATO INTERNO)	FUSIBLE2(O.B)	FUSIBLE (6,3A 250V)
TH3	TERMISTOR	FUSIBLE3(O.B)	FUSIBLE (6,3A 250V)
TH4	TEMPERATURA LÍQUIDO	FUSIBLE4(O.B)	FUSIBLE (6,3A 250V)
TH6	TEMPERATURA DESCARGA	X51 (O.B)	RELÉ MC/CH
C3	CAPACITOR MF	X52 (O.B)	RELÉ 21S4
C5	CAPACITOR MC	F.C (O.B)	CONTROLADOR DEL VENTILADOR
CH	CALEFACTOR DEL CARTER	SW1 (O.B)	DIRECCIÓN DE NUMERO DE GRUPO
52C	CONTACTOR MC	SW4 (O.B)	TEST RUN
21S4	BOBINA DE LA VÁLVULA SOLENOIDE DE 4 VIAS	SW5 (O.B)	SELECCIÓN DE FUNCIÓN
63H	INTERRUPTOR DE PROTECCIÓN DE ALTA PRESIÓN	JA,JB (O.B)	PUENTE CABLEADO
49C	TERMOSTATO INTERNO PARA MC	JI-J6 (O.B)	SELECCIÓN DE MODELO #2
TB1	BLOQUE DE TERMINALES	T (O.B)	TRANSFORMADOR
VEL	VÁLVULA DE EXPANSIÓN LINEAL	CT (O.B)	TRANSFORMADOR DE CORRIENTE
O.B	PLACA CONTROLADORA EXTERIOR	LED1 (O.B)	LED DISPLAY DE VERIFICACIÓN DE OPERACIÓN
		LED2 (O.B)	LED DISPLAY DE VERIFICACIÓN DE OPERACIÓN
		CN31 (O.B)	CONECTOR DE OPERACIÓN DE EMERGENCIA

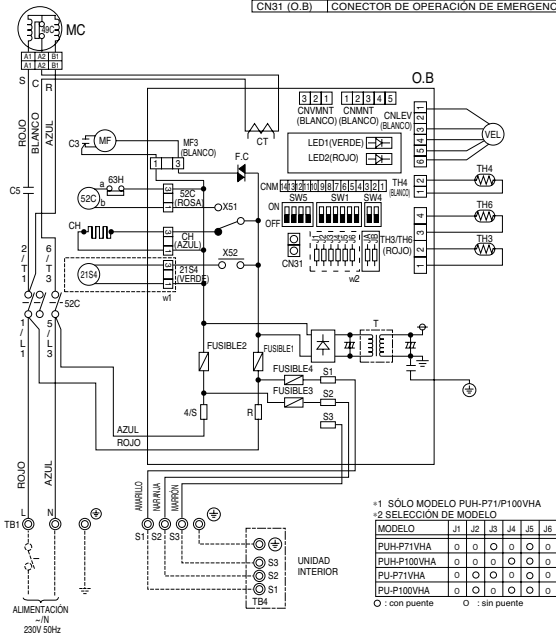

<Notas durante el servicio>

Algunos ajustes de terminales tienen un mecanismo de traba: Cuando remueva un terminal ajustado, presione la proyección (manija de traba) en el terminal con su dedo y tire de él hacia afuera.

PUH-P71YHA PUH-P100YHA PUH-P125YHA PUH-P140YHA
PU-P71YHA PU-P100YHA PU-P125YHA PU-P140YHA

SÍMBOLO	NOMBRE	SÍMBOLO	NOMBRE
MC	COMPRESOR	FUSIBLE1(O.B)	FUSIBLE (6,3A 250V)
MF	MOTOR DEL VENTILADOR (TERMOSTATO INTERNO)	FUSIBLE2(O.B)	FUSIBLE (6,3A 250V)
TH3	TERMISTOR	FUSIBLE3(O.B)	FUSIBLE (6,3A 250V)
TH4	TEMPERATURA LÍQUIDO	FUSIBLE4(O.B)	FUSIBLE (6,3A 250V)
TH6	TEMPERATURA DESCARGA	X51 (O.B)	RELE MC/CH
	TEMPERATURA CONDENSADOR/VAPOADOR	X52 (O.B)	RELE 21S4
C4	CAPACITOR MF	X53 (O.B)	RELE SV
C3	CAPACITOR MF	F.C (O.B)	CONTROLADOR DEL VENTILADOR
CH	CALEFACTOR DEL CÁRTER	SW1 (O.B)	DIRECCIÓN DE NUMERO DE GRUPO
52C	CONTACTOR MC	SW4 (O.B)	TEST RUN
21S4	BOBINA DE LA VÁLVULA SOLENOIDE DE 4 VIAS	SW5 (O.B)	SELECCIÓN DE FUNCIÓN
SV	BOBINA DE LA VÁLVULA SOLENOIDE DE BYPASS	JA,JB(O.B)	JUMPER WIRE
63H	INTERRUPTOR DE PROTECCIÓN DE ALTA PRESIÓN	JI-J6 (O.B)	SELECCIÓN DE MODELO +4
51C	RELE TÉRMICO	TJ (O.B)	TRANSFORMADOR
TB1	BLOQUE DE TERMINALES	CT (O.B)	TRANSFORMADOR DE CORRIENTE
VEL	VÁLVULA DE EXPANSIÓN LINEAL	LED1 (O.B)	LED DISPLAY DE VERIFICACIÓN DE OPERACIÓN
TB2	BLOQUE DE TERMINALES	LED2 (O.B)	LED DISPLAY DE VERIFICACIÓN DE OPERACIÓN
63L	INTERRUPTOR DE PROTECCIÓN DE BAJA PRESIÓN	CN31 (O.B)	CONECTOR DE OPERACIÓN DE EMERGENCIA
O.B	PLACA CONTROLADORA EXTERIOR		

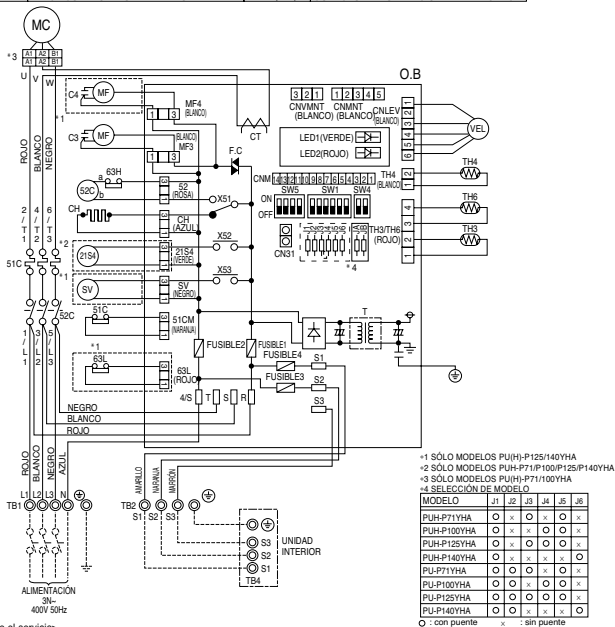

<Notas durante el servicio>

Algunos ajustes de terminales tienen un mecanismo de traba: Cuando remueva un terminal ajustado, presione la proyección (manija de traba) en el terminal con su dedo y tire de él hacia afuera.

10-9. EMERGENCY OPERATION

1. When the outdoor unit becomes under mentioned inspection display. Also when the wired remote controller or micro computer in the indoor unit is broken. If there is not any wrong section, short-circuited connector (CN31) in the outdoor controller board is possible to emergency operation.

● Trouble to which emergency operation can be set

Display	Inspections details
U4	Piping thermistor (TH3) or condenser thermistor (TH6) open/short
E8	Transmission between indoor and outdoor unit Receiving trouble (outdoor unit)
E9	Transmission between indoor and outdoor unit Transmission trouble (outdoor unit)
E0-E7	Transmission trouble except for outdoor unit

2. Check items and notices as the emergency operation

- Be sure that there is no trouble in the outdoor unit any more besides above mentioned.
(When there is trouble besides above mentioned, emergency operation is not available.)
- When the emergency operation, their switch (SWE) setting in the indoor controller board is necessary.
- Emergency operation will be serial operation by the power supply ON/OFF.
ON/OFF or temperature, etc. adjustment is not operated by the remote controller.
- Do not operate for a long time as cold air is blown from the indoor unit, when the outdoor unit starts defrosting operation during heating emergency operation.
- Cool emergency operation must be within 10 hours at most. It may cause heat exchanger frosting in the indoor unit.
- After completing the emergency operation, return the switch setting, etc. in former state.

3. How to operate the emergency operation

- Turn off the main power supply.
- Turn on the emergency switch (SWE) in the indoor controller board.
- Short-circuit the CN31 (emergency operation connector) in the outdoor controller board.
- Set the operation mode (COOL or HEAT) with the SW4-2 in the outdoor controller board.
(SW4-1 cannot be used.)
- Turn on the main power supply.
- The emergency operation starts and be sure of blinking the operation mode display.

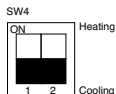

4. Emergency operation details

- Operate with the operation mode which has set (COOL or HEAT) by the SW4-2.
- In the fan operation conditions, the fan is always operated by 100 percent.
- The operation mode display blinks at intervals of 1 second.

5. How to release the emergency operation

- Turn off the main power supply.
- Turn off the emergency switch (SWE) in the indoor controller board.
- Open the CN31 (emergency operation connector) in the outdoor controller board.
- Set the SW4-2 on the outdoor controller board as in the right.



■ Unit operation during emergency operation

Parts name	Operation
Compressor	Always ON
Four way valve	Changeable with SW 4-2
Outdoor fan motor	Max. speed
LEV	Full opening
Indoor fan motor	High

5-1. UNIDAD INTERIOR

PLA-RP•AA(2)

PLH-P•AAH

PMH-P•BA

PEAD-RP•EA(2)

PEHD-P•EAH

PEAD-RP•GA

PKH-P•FALH

PKA-RP•GAL

PKH-P•GALH

PKA-RP•FAL

PCA-RP•GA

PCH-P•GAH

PCA-RP•HA

PSA-RP•GA

PSH-P•GAH

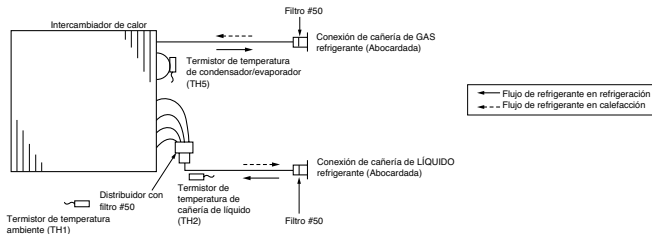

5-2. UNIDAD EXTERIOR

PUH-P71VHA PUH-P100VHA
PUH-P71YHA PUH-P100YHA
PU-P71VHA PU-P100VHA
PU-P71YHA PU-P100YHA

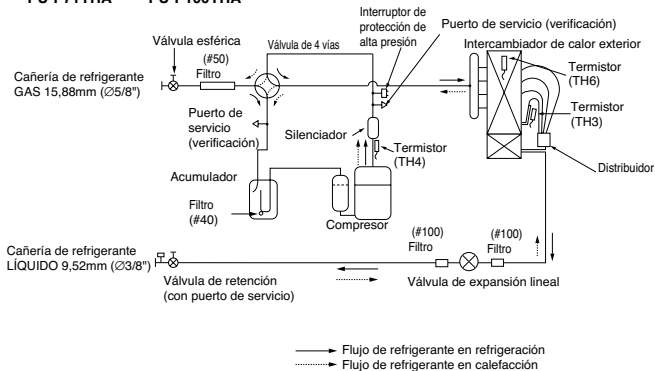

PUH-P125YHA
PUH-P140YHA
PU-P125YHA
PU-P140YHA

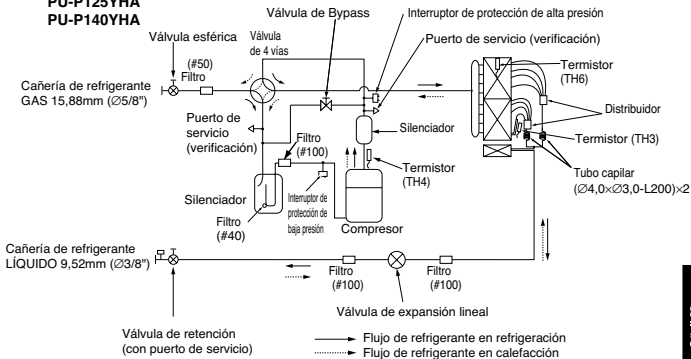

6-1. PARA LA COMBINACIÓN DE UNIDAD EXTERIOR

Capacidad de refrigeración

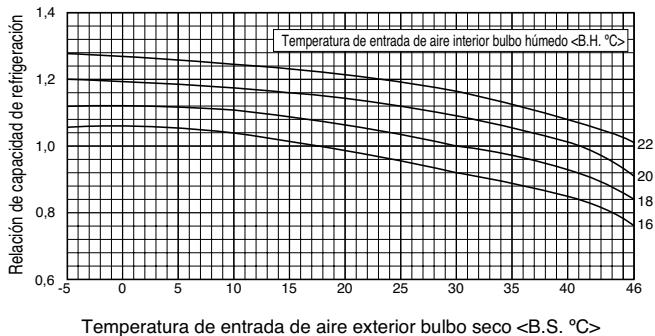

Entrada de refrigeración

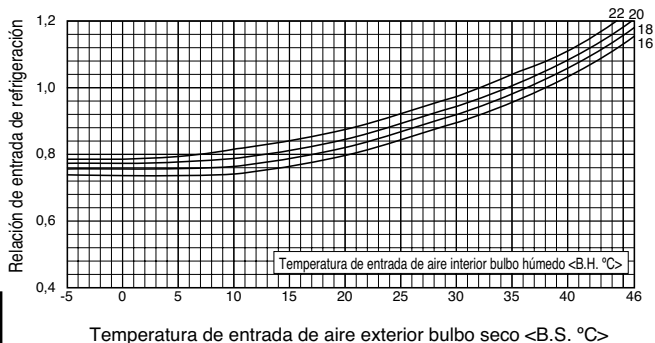

Capacidad de calefacción

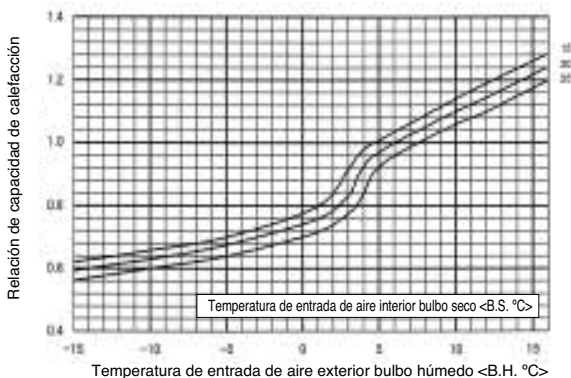

Entrada de calefacción

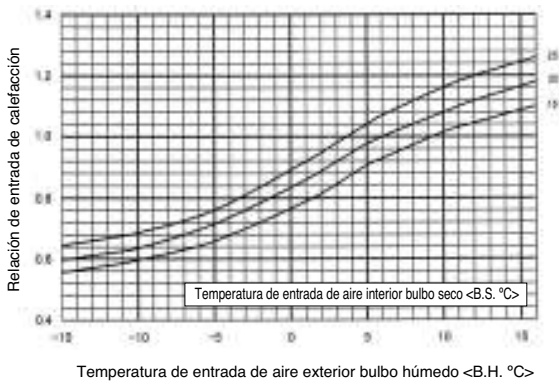

7-1. FACTORES DE CORRECCIÓN DE CAPACIDAD DE REFRIGERACIÓN

Unidad exterior	Longitud de la cañería de refrigerante (un sentido)						
	5m	10m	20m	30m	40m	50m	55m
PU(H)-P71VHA PU(H)-P71YHA	1,00	0,988	0,966	0,946	0,929	0,913	0,905
PU(H)-P100VHA PU(H)-P100YHA	1,00	0,985	0,957	0,931	0,908	0,886	0,876
PU(H)-P125YHA	1,00	0,981	0,946	0,914	0,885	0,858	0,845
PU(H)-P140YHA	1,00	0,976	0,931	0,893	0,858	0,827	0,813

7-2. FACTORES DE CORRECCIÓN DE CAPACIDAD DE CALEFACCIÓN

Unidad exterior	Longitud de la cañería de refrigerante (un sentido)						
	5m	10m	20m	30m	40m	50m	55m
PUH-P71VHA PUH-P71YHA	1,00	0,997	0,991	0,985	0,979	0,973	0,970
PUH-P100VHA PUH-P100YHA	1,00	0,997	0,991	0,985	0,979	0,973	0,970
PUH-P125YHA	1,00	0,997	0,991	0,985	0,979	0,973	0,970
PUH-P140YHA	1,00	0,997	0,991	0,985	0,979	0,973	0,970

8-1. LONGITUD DE CAÑERÍA

8-1-1. 1:1 SISTEMA

Longitud de cañería

<Tabla 1> Longitud máxima de cañería

Cañería de líquido (mm)	OD	Ø6,35			Ø9,52			Ø12,7	
	Espesor	10,8			10,8			10,8	
Cañería de gas (mm)	OD	Ø9,52	Ø12,7	Ø15,88	Ø12,7	Ø15,88	Ø19,05	Ø15,88	Ø19,05
	Espesor	10,8	10,8	11,0	10,8	11,0	11,0	11,0	11,0
P71		□ 10m [10m]	○ 10m [10m]	□ 30m [30m]	Tamaño estándar 50m [30m]			△ 30m [20m]	
	P100,P125,P140				Tamaño estándar 50m [30m]			△ 40m [20m]	

<Marcas en la tabla>

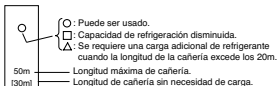

8-1-2. SISTEMAS DOBLES Y TRIPLES

(1) SISTEMA DOBLE

<Tabla 2> Longitud máxima de cañería

Cañería principal (mm) [A]	Cañería de líquido	P71(RP35× 2)		P100(RP50× 2)		P125(RP60× 2)+P140(RP71× 2)		
		Ø6,35	Ø9,52	Ø9,52	Ø9,52	Ø12,7	Ø9,52	Ø12,7
Cañería de rama (mm) [B,C]	Cañería de gas	Ø12,7	Ø15,88	Ø15,88	Ø19,05	Ø19,05	Ø15,88	Ø19,05
	Cañería de líquido	Ø6,35	Tamaño estándar 50m [30m]	Tamaño estándar 50m [30m]				
	Cañería de gas	Ø12,7						
	Cañería de líquido	Ø9,52					Tamaño estándar 50m [30m]	
	Cañería de gas	Ø15,88		○ 50m [30m]	○ 50m [30m]			
	Cañería de líquido	Ø12,7						
Cañería de gas	Ø19,05							

(2) SISTEMA TRIPLE

<Tabla 3> Longitud máxima de cañería

Cañería principal (mm) [A]	Cañería de líquido	P140(RP50× 3)		
		Ø9,52	Ø9,52	Ø12,7
Cañería de rama (mm) [B,C,D]	Cañería de gas	Ø15,88	Ø19,05	Ø19,05
	Cañería de líquido	Ø6,35	Tamaño estándar 50m [30m]	
	Cañería de gas	Ø12,7		
	Cañería de líquido	Ø9,52		● 50m [30m]
	Cañería de gas	Ø15,88		
	Cañería de líquido	Ø12,7		
Cañería de gas	Ø19,05			

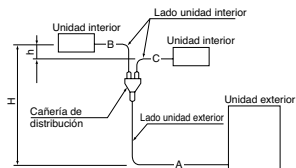

<SISTEMA DOBLE>
Longitud total A + B + C
P71-140: 50 m

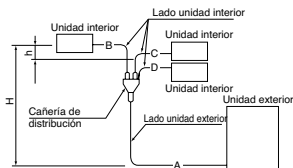

<SISTEMA TRIPLE>
Longitud total A + B + C + D
P140: 50 m

(3) Tamaño de cañería y límite de cañería de refrigerante

	Unidad exterior	Pipe size (mm)				Longitud actual de cañería <m>			Diferencia de altura<m>		(Nota 1) Cantidad de curvas
		Lado gas		Lado líquido		Longitud total A+B+C+D	Interior ~ Interior	Cañería de rama B, C, D	Interior ~ Exterior	Interior ~ Interior	
		Lado unidad exterior	Lado unidad interior	Lado unidad exterior	Lado unidad interior						
DOBLE	71-140	∅15,88<5/8>	RP35,50 ∅12,7<1/2>	∅9,52<3/8>	RP35,50 ∅6,35<1/4>	50m	IB-CI 8m	20m	H30m	h 1m	15
TRIPLE	140	∅15,88<5/8>	RP60,71 ∅15,88<5/8>	∅9,52<3/8>	RP60,71 ∅9,52<3/8>	50m	IB-CI IC-DI IB-DI 8m				

Nota1. La cantidad de curvas en la cañería de refrigerante es respectivamente 8 o menos en el rango de <A+B> <A+C> <A+D>
2. PU(H)-P71,100,125,140 : 30m sin carga

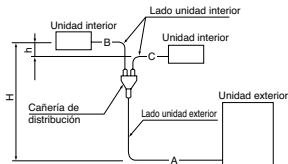

<SISTEMA DOBLE>
Longitud total A + B + C
P71-140: 50 m

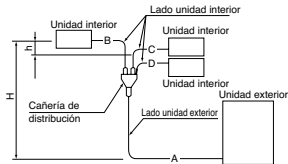

<SISTEMA TRIPLE>
Longitud total A + B + C + D
P140: 50 m

8.2. AJUSTANDO LA CANTIDAD DE REFRIGERANTE

- Verifique la cantidad adicional de refrigerante refiriéndose a la tabla 5.6 cuando la cañería de líquido es una medida mayor que el diámetro estándar

<Tabla 5> Carga adicional de refrigerante requerida cuando el tamaño de la cañería es mayor que el diámetro estándar (SISTEMA 1:1)

	∅ de cañería de líquido	Sin carga	Long. máx. d cañería	Cantidad de refrigerante a agregarse
PUH-P71,P100	∅12,7	20m	30m	100 g por cada m por encima de 20m
PUH-P125,P140	∅12,7	20m	40m	100 g por cada m por encima de 20m
PU-P71,P100	∅12,7	20m	30m	50 g por cada m por encima de 20m
PU-P125,P140	∅12,7	20m	40m	50 g por cada m por encima de 20m

<Tabla 6> Carga adicional de refrigerante requerida cuando el tamaño de la cañería es mayor que el diámetro estándar (SISTEMA DOBLE/TRIPLE)

Capacidad	Cuando la longitud de extensión de cañería (cañería principal + cañería de ramificación) excede 20 m
P71,100,125,140	Cantidad adicional de refrigerante ΔW(g) = (100 × L1) + (60 × L2) + (30 × L3) - 2000

Si los cálculos producen un número negativo (ΔW<0), no es necesario agregar refrigerante.

L1:∅12,7 longitud de cañería de líquido (m)

L2:∅9,52 longitud de cañería de líquido (m)

L3:∅6,35 longitud de cañería de líquido (m)

<Tabla 7> Carga adicional de refrigerante requerida para cañería de diámetro estándar





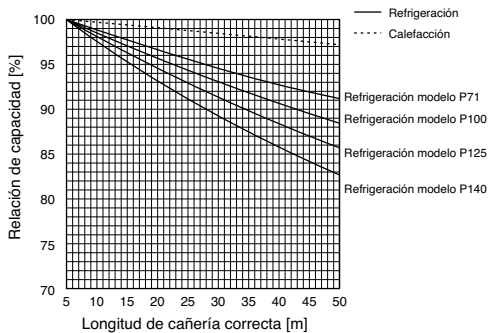











Unidad exterior	Longitud de cañería permitida	Cantidad de refrigerante de relleno en la unidad (kg)	Cantidad de carga de refrigerante adicional para longitud de cañería que exceda los 30m (kg)	
			31 - 40m	41 - 50m
PU(H)-P71V/YHA	50m o menos	3,6kg	0,6kg	1,2kg
PU(H)-P100V/YHA	50m o menos	4,4kg	0,6kg	1,2kg
PU(H)-P125,140YHA	50m o menos	5,0kg	0,6kg	1,2kg

8-3. CURVA DE CAPACIDAD



10-10. FUNCTION OF SWITCHS, CONNECTORS AND JUMPERS

● Outdoor switch for a new freon function table

Switch Signal No.	Function	Action by the switch operation		Effective timing		
		ON	OFF			
SW1	1 Compulsory defrosting w1	Start	Normal	Heat compressor operating		
	2 Abnormal history clear	Clear	Normal	off or operating		
3 6	Refrigerant address setting					When power supply ON
						
						
						
SW4	1 Test run ON/OFF	ON	OFF	OFF		
	2 Test run mode setting	Heat	Cool			
SW5	1 Fan 100% fix	100% fix	Normal	off or operating		
	2 Outdoor LEV opening fix w2	Fix	Normal	off or operating		
	3 No function	No function	No function	-		
	4 Length of defrost operation	20 minutes	15 minutes (Normal)	Always		

※1 Compulsory defrosting should be done as follows.

① Change the DIP SW1-1 in the outdoor controller board OFF→ ON (compulsory defrosting start).

According to the ① operation,

- Heat mode setting • Compressor operating • The defrosting starts when the piping temperature is 8°C and below.
- When the stated condition is satisfied, the defrosting operation will be completed.

※2 Ignore the change of LEV opening, which is subject to change of subcooling, and fix DIP SW 5-2 in the on position. Then LEV opening is fixed. When air conditioner is overloaded for some reasons, ignore the change of subcooling and adjust the LEV opening in accordance with overload condition.

● Jumper connector function table

Switch		Function	Action by the switch operation		Effective timing																													
Signal	No.		ON (With jumper wire)	OFF (Without jumper wire)																														
J1		Switch of single phase and 3 phase power supply	3 phase	Single phase	When power supply ON																													
J2		Switch of cooling only/ heat pump	Cooling only	Heat pump	When power supply ON																													
J3		Capacity switch	O: with jumper wire x: without jumper wire		When power supply ON																													
J4			<table border="1"> <thead> <tr> <th rowspan="2">Model</th> <th colspan="4">Setting</th> </tr> <tr> <th>J3</th> <th>J4</th> <th>J5</th> <th>J6</th> </tr> </thead> <tbody> <tr> <td>P71</td> <td>○</td> <td>x</td> <td>○</td> <td>x</td> </tr> <tr> <td>P100</td> <td>x</td> <td>○</td> <td>○</td> <td>x</td> </tr> <tr> <td>P125</td> <td>○</td> <td>○</td> <td>○</td> <td>x</td> </tr> <tr> <td>P140</td> <td>x</td> <td>x</td> <td>x</td> <td>○</td> </tr> </tbody> </table>			Model	Setting				J3	J4	J5	J6	P71	○	x	○	x	P100	x	○	○	x	P125	○	○	○	x	P140	x	x	x	○
Model	Setting																																	
	J3		J4	J5		J6																												
P71	○		x	○		x																												
P100	x	○	○	x																														
P125	○	○	○	x																														
P140	x	x	x	○																														
J5																																		
J6																																		
CN31		Emergency operation	Emergency operation	Normal	When power supply ON																													
JA		Auto restart	Normal	Auto restart	When power supply ON																													
JB		Separate inoor / outdoor power supply	Ineffective	Effective																														

10-11. OPTIONAL PARTS

A-control Service Tool [PAC-SK52ST]

● Function of switches

Type of switches	Switch	No.	Function	Action by the switch operation		Effective timing
				ON	OFF	
DIP SW	SW2	1	Changing of LED display <Self-diagnosis>	Operation monitor	Operation monitor	Under operation or suspension
		2				
		3				
		4				
		5				
		6				

Note : Do not use CN33.

CONTROL A

(MONOFASICO)

R-410

▲ Sólo en el caso de que la unidad interior disponga de resistencias eléctricas de apoyo, deberá alimentarse también la unidad interior con 230V y dotar a esta de su correspondiente sección de cable, así como su correspondiente protección eléctrica, línea "C".

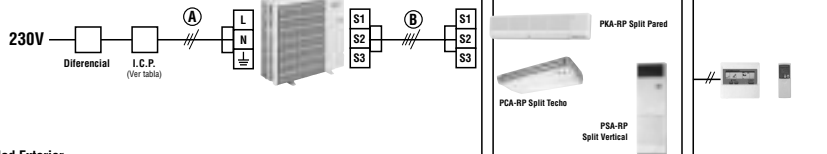

Modelo Unidad Exterior

PU-P71VHA PUH-P71VHA
PU-P100VHA PUH-P100VHA

El circuito frigorífico con LEV (Válvula Expansión Lineal) y un gran acumulador controlan siempre el nivel óptimo de refrigerante sin tener en cuenta la longitud de tubería (20/30 m máx. y 5 m mín) sin necesidad de añadir más gas. Para longitudes superiores a 30 mts.

Datos de Instalación

MODELO CV	SECCIÓN A mm ²	SECCIÓN B mm ²	SECCIÓN C mm ²	INTENSIDAD NOMINAL (A)		CONSUMO MÁXIMO (A)	I.C.P (A) CURVA C	TUB. FRIGOR.		DISTANCIAS FRIGORIFICAS		NUMERO CURVAS	PRECARGA DE GAS HASTA
				FRIO	CALOR			LIQUIDO	GAS	MAXIMA VERTICAL	TOTAL VERTICAL + HORIZONTAL		
71	2 x 6 +T	3 x 2,5 +T	VER ▲	13,58	13,53	22,5	32	3/8"	5/8"	50	50	12	30
100	2 x 6 +T	3 x 2,5 +T	VER ▲	17,6	17,01	30,5	32	3/8"	5/8"	50	50	15	30

CONTROL A

(TRIFASICO)

R-410

▲ Sólo en el caso de que la unidad interior disponga de resistencias eléctricas de apoyo, deberá alimentarse también la unidad interior con 230V y dotar a esta de su correspondiente sección de cable, así como su correspondiente protección eléctrica, línea "C".

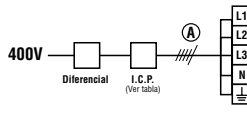

Modelo Unidad Exterior

PU-P71YHA	PUH-P71YHA
PU-P100YHA	PUH-P100YHA
PU-P125YHA	PUH-P125YHA
PU-P140YHA	PUH-P140YHA

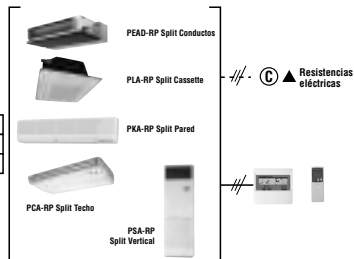

El circuito frigorífico con LEV (Válvula Expansión Lineal) y un gran acumulador controlan siempre el nivel óptimo de refrigerante sin tener en cuenta la longitud de tubería (20/30 m máx. y 5 m mín) sin necesidad de añadir más gas. Para longitudes superiores a 30 mts.

Datos de Instalación

MODELO CV	SECCIÓN A mm ²	SECCIÓN B mm ²	SECCIÓN C mm ²	INTENSIDAD NOMINAL (A)		CONSUMO MÁXIMO (A)	I.C.P (A) CURVA C	TUB. FRIGOR.		DISTANCIAS FRIGORIFICAS		NUMERO CURVAS	PRECARGA DE GAS HASTA
				FRIO	CALOR			LIQUIDO	GAS	MAXIMA VERTICAL	TOTAL VERTICAL + HORIZONTAL		
71	3 x 2,5 + N + T	3 x 2,5 + T	VER ▲	5,84	5,83	25,5	16	3/8"	5/8"	50	50	12	30
100	3 x 2,5 + N + T	3 x 2,5 + T	VER ▲	7,92	7,71	30,5	16	3/8"	5/8"	50	50	15	30
125	3 x 4 + N + T	3 x 2,5 + T	VER ▲	9,41	9,19	15,1	25	3/8"	5/8"	50	50	15	30
140	3 x 4 + N + T	3 x 2,5 + T	VER ▲	11,24	11,14	18,7	25	3/8"	5/8"	50	50	15	30



DATOS DE FLUJO DE AIRE

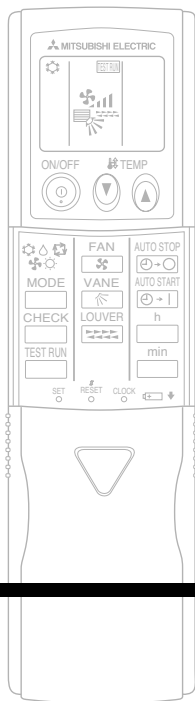

PLA·RP·AA
PEAD·RP·EA
PEAD·RP·GA
PKA·RP·GAL
PKA·RP·FAL
PCA·RP·GA
PSA·RP·GA

9-1, VELOCIDAD DEL AIRE DE SALIDA Y RANGO DE COBERTURA

	PCA-RP50KA	PCA-RP60KA	PCA-RP71KA	PCA-RP100KA	PCA-RP125KA	PCA-RP140KA
Airflow m ³ /min.	18	18	21	30	31	32
Air speed m/sec.	3.2	3.2	3.7	5.3	5.4	5.6
Coverage range m	4.8	4.8	5.6	8.0	8.2	8.5

	PCA-RP50KA	PCA-RP60KA	PCA-RP71KA	PCA-RP100KA	PCA-RP125KA	PCA-RP140KA
Airflow m ³ /min.	15	19	20	28	29	32
Air speed m/sec.	3.3	3.1	3.2	3.6	3.7	4.1
Coverage range m	9.0	9.6	10.1	12.5	12.9	14.2

	PCA-RP71HA	PCA-RP125HA
Airflow m ³ /min.	19	38
Air speed m/sec.	2.9	4.2
Coverage range m	7.9	13.2

	PKA-RP50HAL
Airflow m ³ /min.	12
Air speed m/sec.	6.1
Coverage range m(ft)	10.8(35.4)

	PKA-RP60KAL	PKA-RP71KAL	PKA-RP100KAL
Airflow m ³ /min.	22	22	26
Air speed m/sec.	6.0	6.0	6.8
Coverage range m(ft)	14.3(46.9)	14.3(46.9)	16.1(52.8)

	PSA-RP71GA	PSA-RP100GA	PSA-RP125GA	PSA-RP140GA
Airflow m ³ /min.	18	31	33	35
Air speed m/sec.	2.6	4.5	4.8	4.9
Coverage range m	8.3	14.3	15.2	16.1

* The air coverage range is the distance to which the 0.25m/sec air can reach, when air is blown out horizontally from the unit at the High notch position.
The coverage range should be used only as a general guideline since it varies according to the size of the room and the furniture inside the room.

9-2. PLA-RP-BA

9-2-1 FRESH AIR INTAKE AND BRANCH DUCT

1. Branch duct hole and fresh air intake hole (Fig. 1)

At the time of installation, use the duct holes (cut out) located at the positions shown in Fig.1, as and when required.

* A fresh air intake hole for the optional multi function casement can also be made.

Note:

The figure marked with * in the drawing represent the dimensions of the main unit excluding those of the optional multi function casement.

When installing the optional multi function casement, add 135 mm to the dimensions marked on the figure.

When installing the branch ducts, be sure to insulate adequately.

Otherwise condensation and dripping may occur.

Unit : mm

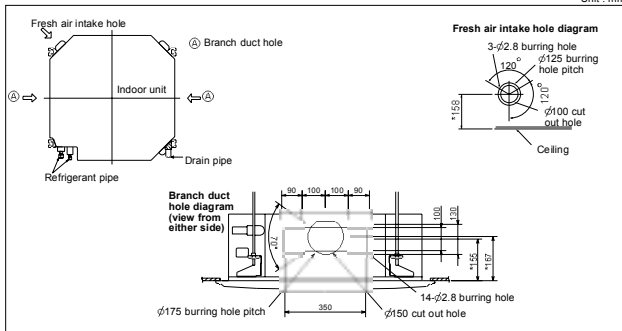
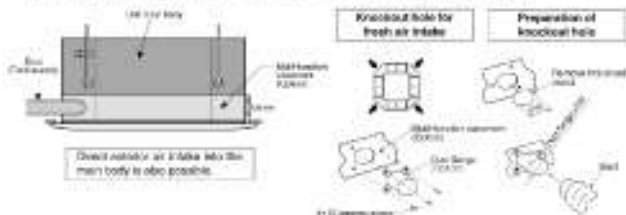

Fig. 1

2. Fresh air intake (Installation at site)

- By installing the optional multi-function casement to the indoor unit main body and installing the duct and duct baffle (see Fig. 1) onto it from the fresh air intake air intake can be accomplished. (The rebounding of the sub-function casement increases the height of the ceiling, attach by 150mm.)



3. Fresh air intake volume & static pressure characteristics

PLA-RP25-710A21

① Air saving multi-inlet filter consumption, standard filter

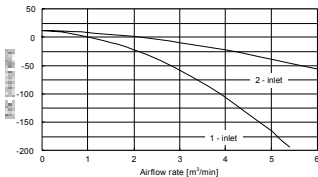

② Direct intake to wall

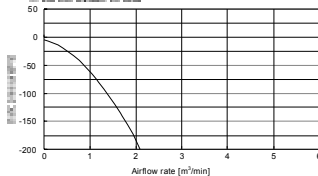

PLA-RP1000W1X PLA-RP125-1400A12

① Air saving multi-inlet filter consumption, standard filter

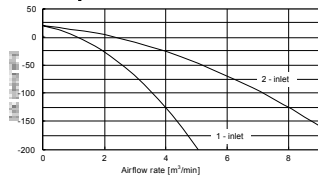

② Direct intake to wall

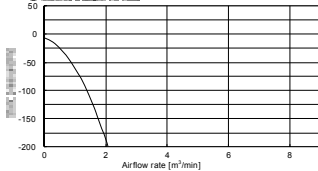

How to read the chart

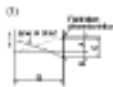

D — Design Total air intake volume (m³/min)



A — Static pressure loss (Pst) of both air intake duct at airflow rate of Q

B — Required boost pressure (Pst) of air conditioner (static airflow rate of Q)



C — Required static pressure (Pst) of fan unit at airflow rate of Q

D — Required compensation (Pst) for static pressure loss of both air intake ducts at airflow rate Q

E — Static pressure (Pst) of indoor unit at airflow rate of Q

Ga — Estimated fan air intake (motor) without compensation of D

② Air saving multi-inlet filter consumption, high efficiency filter

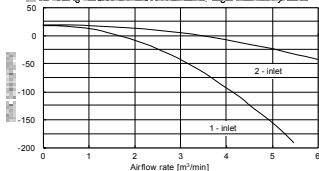

② Air saving multi-inlet filter consumption, high efficiency filter

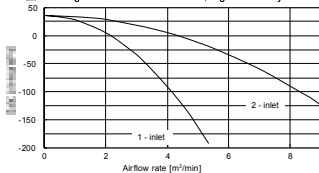

4. Change of outlet numbers

[The optional air outlet is necessary.]
To change the air outlet number to 3-, or 2-way outlet, the outlet number should be closed with the operational air outlet shutter.

(When the air outlets are closed, close the vane by removing the vane connector.)

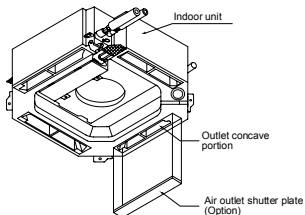
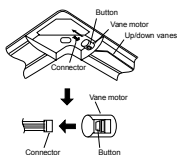

Branch duct and change of outlet numbers

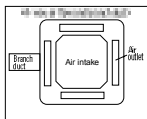

※ Branch duct should be connected to one of the branch duct holes on the main unit.

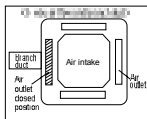

※ Close the outlet on the side of branch duct and air flows in 3 directions.

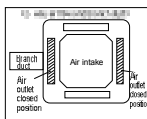

※ Close the outlet on the side of branch duct and one of the other outlets. Air flows in 2 directions.

PLA-RP71BA(2)

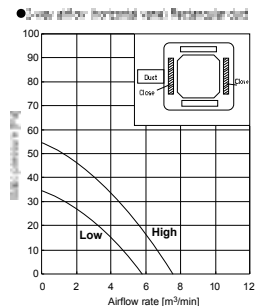
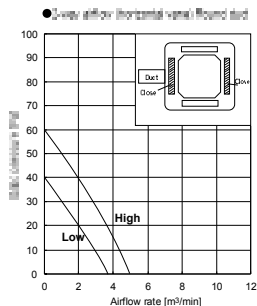
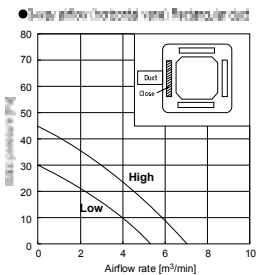
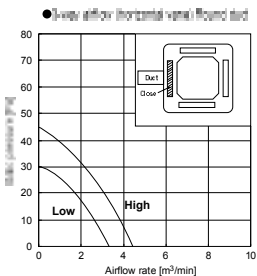
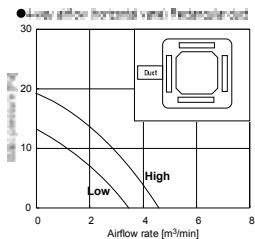
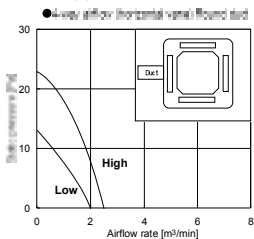

- Use 1 of the 2 duct holes on the indoor unit.
- Airflow rate of PLA-RP50, 60BA can be calculated from the airflow rate based on the characteristic of the duct for PLA-RP71BA(2).
- Use the optional air outlet shutter plate (PAC-SH51SP-E) for 3-way and 2-way airflow.

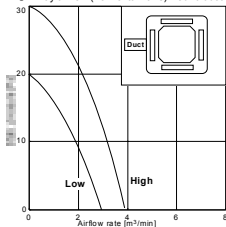
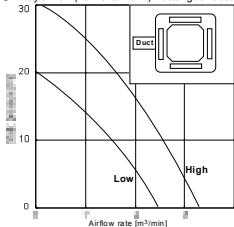
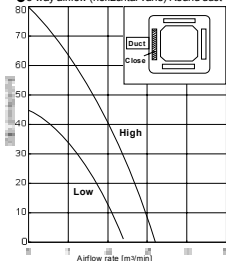
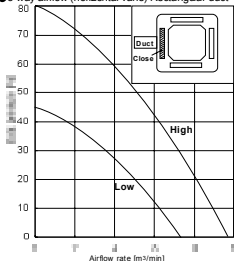
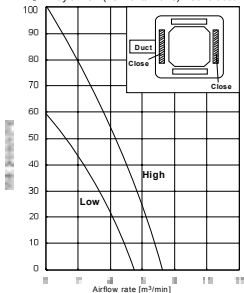
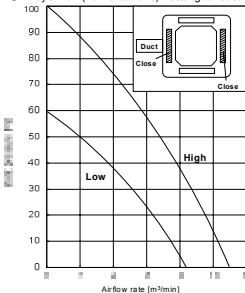
PLA-RP125BA(2)
● 4-way airflow (horizontal vane) Round duct

● 4-way airflow (horizontal vane) Rectangular duct

● 3-way airflow (horizontal vane) Round duct

● 3-way airflow (horizontal vane) Rectangular duct

● 2-way airflow (horizontal vane) Round duct

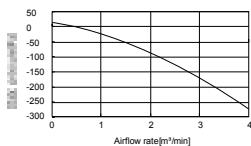
● 2-way airflow (horizontal vane) Rectangular duct

- Use 1 of the 2 duct holes on the indoor unit.
- Airflow rate of PLA-RP100BA(3), PLA-RP140BA2 can be calculated from the airflow rate based on the characteristic of the duct for PLA-RP125BA(2).
- Use the optional air outlet shutter plate (PAC-SH51SP-E) for 3-way and 2-way airflow.

9-3. PCA-RP-KA

Fresh air intake amount & static pressure characteristics

■ PCA-RP50KA



■ PCA-RP100, 125, 140KA

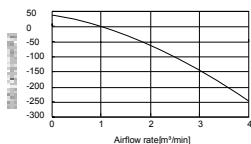

■ PCA-RP60, 71KA

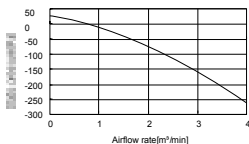

How to read the chart



Q ... Design fresh air intake volume (m³/min)

A ... Static pressure loss (Pa) of fresh air intake duct at airflow rate of Q

B ... Required total pressure (Pa) of air conditioner at the air-flow rate of Q

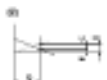

C ... Required static pressure (Pa) of indoor fan at airflow rate of Q

D ... Required compensation (Pa) for static pressure loss of fresh air intake duct at flow rate Q



E ... Static pressure (Pa) of indoor unit at airflow rate of Q

G ... Estimated fresh air intake per unit without compensation of D

9-4. PEAD-RP-JA(L) Fan performance

PEAD-RP50JA(L)

(External static pressure 35Pa) 220-240V 50Hz

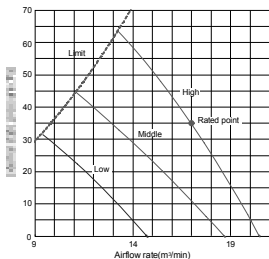

PEAD-RP50JA(L)

(External static pressure 100Pa) 220-240V 50Hz

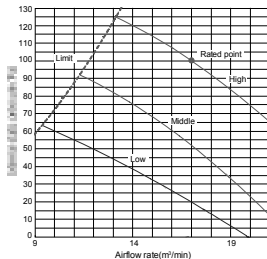

PEAD-RP50JA(L)

(External static pressure 50Pa) 220-240V 50Hz

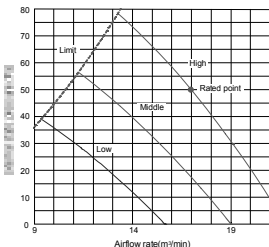

PEAD-RP50JA(L)

(External static pressure 150Pa) 220-240V 50Hz

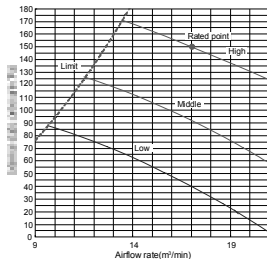

PEAD-RP50JA(L)

(External static pressure 70Pa) 220-240V 50Hz

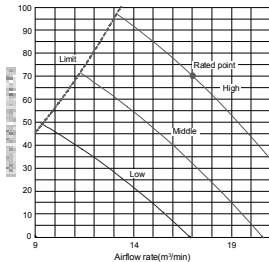

PEAD-RP60JA(L)
(External static pressure 35Pa) 220-240V 50Hz

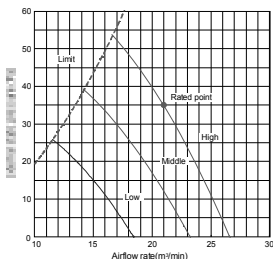

PEAD-RP60JA(L)
(External static pressure 100Pa) 220-240V 50Hz

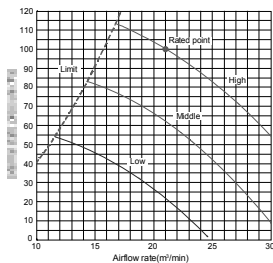

PEAD-RP60JA(L)
(External static pressure 50Pa) 220-240V 50Hz

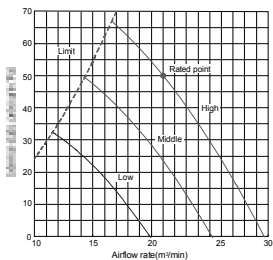

PEAD-RP60JA(L)
(External static pressure 150Pa) 220-240V 50Hz

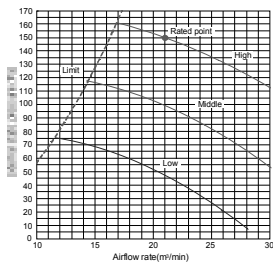

PEAD-RP60JA(L)
(External static pressure 70Pa) 220-240V 50Hz

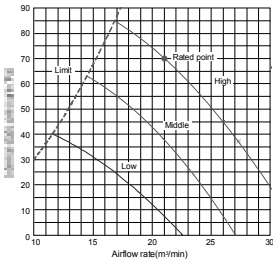

PEAD-RP71JA(L)
(External static pressure 35Pa) 220-240V 50Hz

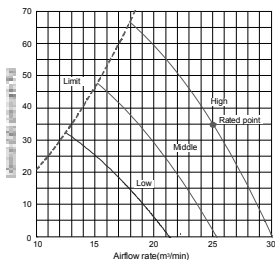

PEAD-RP71JA(L)
(External static pressure 100Pa) 220-240V 50Hz

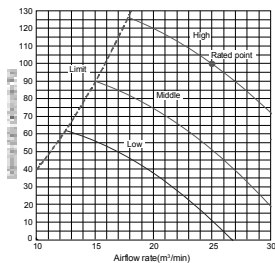

PEAD-RP71JA(L)
(External static pressure 50Pa) 220-240V 50Hz

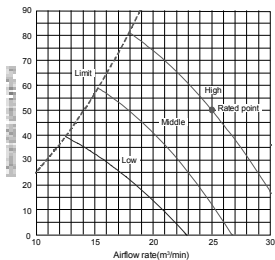

PEAD-RP71JA(L)
(External static pressure 150Pa) 220-240V 50Hz

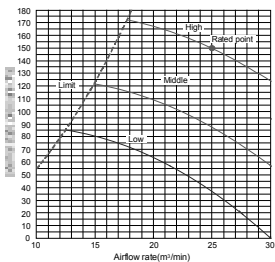

PEAD-RP71JA(L)
(External static pressure 70Pa) 220-240V 50Hz

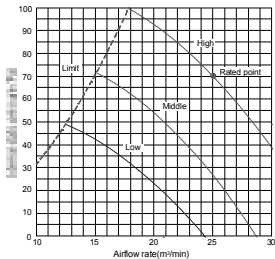

PEAD-RP100JA(L)
(External static pressure 35Pa) 220-240V 50Hz

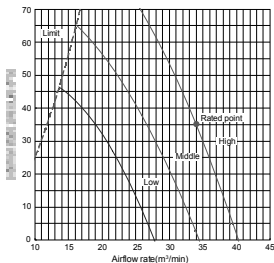

PEAD-RP100JA(L)
(External static pressure 100Pa) 220-240V 50Hz

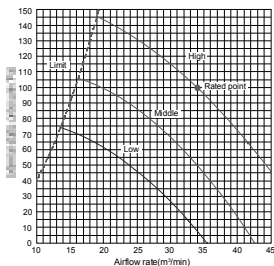

PEAD-RP100JA(L)
(External static pressure 50Pa) 220-240V 50Hz

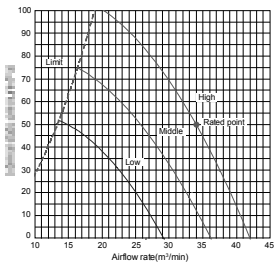

PEAD-RP100JA(L)
(External static pressure 150Pa) 220-240V 50Hz

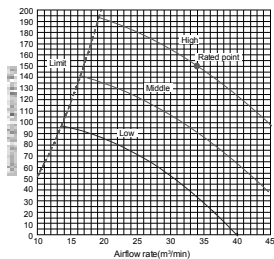

PEAD-RP100JA(L)
(External static pressure 70Pa) 220-240V 50Hz

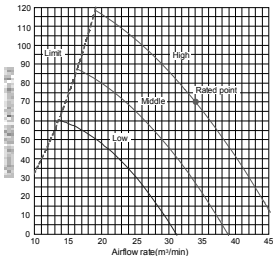

PEAD-RP125JA(L)
(External static pressure 35Pa) 220-240V 50Hz

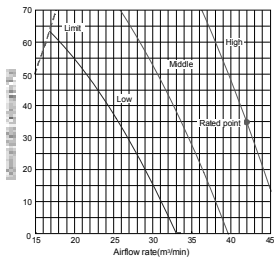

PEAD-RP125JA(L)
(External static pressure 100Pa) 220-240V 50Hz

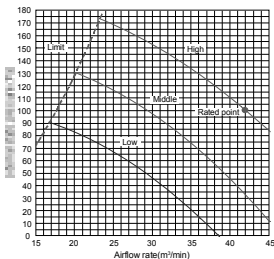

PEAD-RP125JA(L)
(External static pressure 50Pa) 220-240V 50Hz

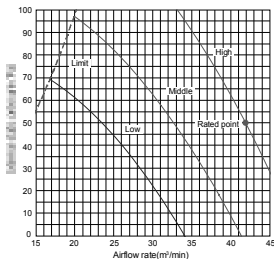

PEAD-RP125JA(L)
(External static pressure 150Pa) 220-240V 50Hz

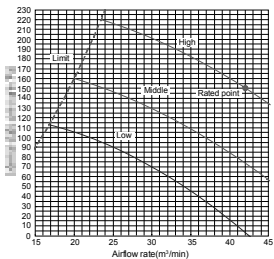

PEAD-RP125JA(L)
(External static pressure 70Pa) 220-240V 50Hz

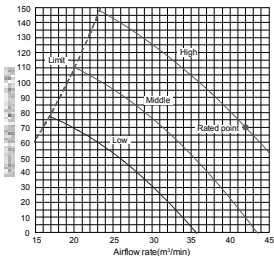

PEAD-RP140JA(L)
(External static pressure 35Pa) 220-240V 50Hz

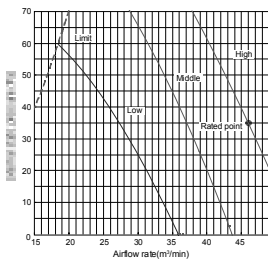

PEAD-RP140JA(L)
(External static pressure 100Pa) 220-240V 50Hz

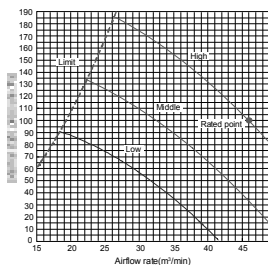

PEAD-RP140JA(L)
(External static pressure 50Pa) 220-240V 50Hz

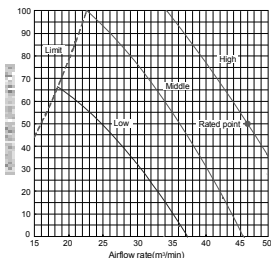

PEAD-RP140JA(L)
(External static pressure 150Pa) 220-240V 50Hz

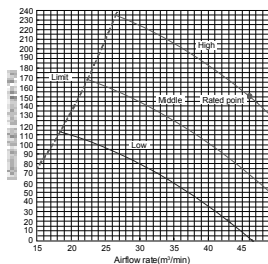

PEAD-RP140JA(L)
(External static pressure 70Pa) 220-240V 50Hz

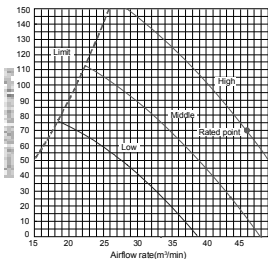

9-5. PEA-RP-GA

Fan Performance Curve

PEA-RP200GA
Fan Performance Curve 50Hz

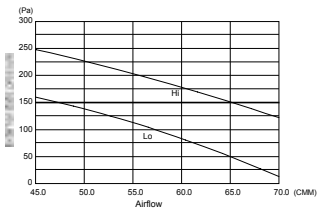

PEA-RP250GA
Fan Performance Curve 50Hz

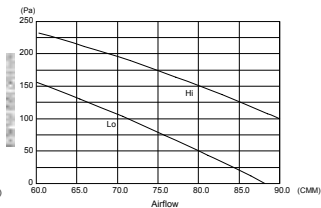

PEA-RP400GA
Fan Performance Curve 50Hz

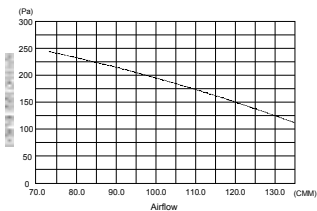

PEA-RP500GA
Fan Performance Curve 50Hz

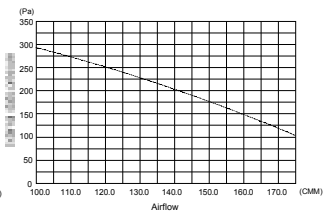



RESOLUCIÓN DE AVERIAS

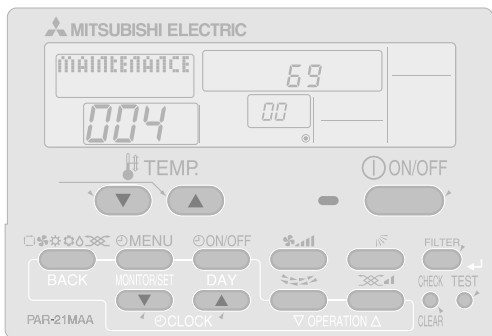

11-1. BÚSQUEDA DE ERRORES

<Código de error exhibido por el autodiagnóstico y acciones a tomar en el servicio (sumario)>

Los códigos de error presentes y pasados son registrados y exhibidos en el control remoto cableado o la placa controladora de la unidad exterior. Las acciones a ser tomadas para el servicio y la recurrencia de los fenómenos de abajo en el campo se sumanizan en la tabla de abajo. Verifique los contenidos de abajo antes de investigar los detalles.

Condiciones de la unidad en servicio	Código de error	Acciones a tomar en el servicio (sumario)
El fenómeno inferior es recurrente	Exhibido	Determine que está mal y tome la acción correctiva de acuerdo a "11-4. Tabla de acción de autodiagnóstico".
	No exhibido	Identifique la causa del fenómeno inferior y tome una acción correctiva de acuerdo a "11-5. Búsqueda de errores por el fenómeno inferior".
El fenómeno inferior no es recurrente	Registrado	<ol style="list-style-type: none"> 1 Considere los defectos temporarios tales como el trabajo de los dispositivos de protección en el circuito refrigerante incluyendo el compresor, conexión pobre del cableado, ruido, etc. Verifique el síntoma, y verifique el entorno de la instalación, cantidad de refrigerante, clima cuando ocurrió el fenómeno inferior y cableados. 2 Reseteo los registros de código de error y reinicie la unidad después de finalizar el servicio. 3 No hay anomalía en componentes electrónicos, placas controladoras y control remoto.
	No registrado	<ol style="list-style-type: none"> 1 Reverifique el síntoma anormal. 2 Identifique la causa del fenómeno inferior y tome una acción correctiva de acuerdo a "11-5. Búsqueda de errores por el fenómeno inferior" 3 Continúe operando la unidad por un tiempo para determinar si la causa no fué ocasional. 4 No hay anomalía en componentes electrónicos, placas controladoras, control remoto, etc.

11-2. PUNTO DE PRUEBA BAJO TEST RUN

(1) Antes del test run

- Después de la instalación de las unidades interior y exterior, trabajos en las cañerías y de instalación eléctrica, reverifique que no haya fugas de refrigerante, contactos flojos y polaridades incorrectas.
- Mida la impedancia entre tierra y el bloque de terminales de alimentación (L, N) de la unidad exterior mediante un Megger de 500V y verifique que la impedancia sea superior a 1MΩ.
- No utilice el megger de 500V para el bloque de terminales de conexión interior/exterior (S1, S2 y S3) ni para el bloque de terminales del control remoto (1, 2). Esto puede causar daños.
- Asegúrese de que el interruptor del test run (SW4) esté configurado en OFF antes de encender la alimentación.
- Encienda la alimentación doce horas antes del test run para proteger al compresor.
- Para modelos específicos que requieren mayores configuraciones de ciclo de vida o características de autorrecupero desde una falla eléctrica, efectúe los cambios apropiados de la configuración refiriéndose a la descripción de "Seleccionado las Funciones desde el Control Remoto". Asegúrese de leer el manual de operación antes del test run. (Especialmente los ítems referidos a la seguridad).

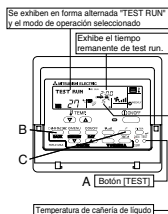

Procedimientos de operación	
1. Encienda la alimentación principal.	Mientras que el display de temperatura ambiente del control remoto dice "PLEASE WAIT", el control remoto está deshabilitado. Espere hasta que desaparezca "PLEASE WAIT" antes de utilizar el control remoto. "PLEASE WAIT" aparece durante aproximadamente 2 minutos después de encender la alimentación. *1
2. Presione dos veces el botón A (TEST)	Aparecerá el [TEST RUN] en la pantalla.
3. Presione el botón B (OPERATION SWITCH)	Modo refrigeración: Verifique si sopla aire fresco y drena agua. Modo calefacción: Verifique si sopla aire cálido. (Demora un poco hasta que sople air cálido)
4. Presione el botón C (AIR DIRECTION)	Verifique el correcto funcionamiento de las aletas automáticas.
5. Verifique el correcto funcionamiento del ventilador de la unidad exterior.	La unidad exterior tiene la característica de control automático de capacidad para brindar una velocidad óptima de velocidad de ventilador. Por lo tanto, el ventilador permanece funcionando a baja velocidad para alcanzar las condiciones actuales de aire exterior a menos que exceda su potencia máxima disponible. Entonces, en la actualidad, el ventilador puede detenerse o funcionar en sentido inverso dependiendo del aire exterior, pero no significa mal funcionamiento.
6. Presione el botón (ON/OFF) para resetear el test run en progreso.	
7. Registre el número de contacto.	

- En el caso del test run, se activará el temporizador de apagado, y el test run se detendrá automáticamente después de dos horas.
- La sección del display de temperatura ambiente muestra la temperatura de cañería de las unidades interiores durante el test run.
- Verifique que todas las unidades interiores estén funcionando correctamente en caso de operación simultánea doble y triple. No se pueden exhibir las fallas independientemente del cableado incorrecto.

*1 Después de encender la alimentación, el sistema entrará en el modo de inicialización, parpadeará "PLEASE WAIT" en la sección del display de temperatura ambiente, y parpadeará la lámpara (verde) del control remoto.

Con respecto al LED de la placa interior, LED1 se encenderá, LED2 podrá tanto encenderse en caso que la dirección sea 0 o apagarse en caso que la dirección no sea 0. LED3 parpadeará.

Con respecto al LED de la placa exterior, LED1 (verde) y LED2 (rojo) se encenderán. (Después que termine el modo de inicialización del sistema, se apagará el LED2 (rojo).)

En el caso de los LED de la placa exterior sea display digital, se exhibirá en forma alternada [N] y [N] a cada segundo.

- Si alguna de las operaciones de arriba no funciona correctamente, considere las causas descritas abajo. Encuentre las causas en función de los síntomas.

Los síntomas de abajo son bajo el modo test run. En la tabla "startup" significa el estado del display *1 mostro arriba.

Síntomas en el test run		Causa
Display del Control Remoto	Display LED de la Placa Exterior	
El control remoto exhibe "PLEASE WAIT" y no puede ser operado.	Después de exhibir "startup", sólo se enciende la luz verde. <00>	<ul style="list-style-type: none"> Después de conectarse la alimentación, se exhibe "PLEASE WAIT" por 2 minutos durante el arranque del sistema. (Normal) Conexión incorrecta del bloque de terminales exterior (L1, L2 y L3 y S1, S2 y S3).
Después de encender la alimentación, se exhibirá "PLEASE WAIT" por 3 minutos, luego se exhibirá el código de error.	After OstartupO is displayed, green(once) and red(once) blink alternately. <F1>	<ul style="list-style-type: none"> Está abierto el conector de autoprotección de instalación exterior.
No aparece display aún cuando está encendido el interruptor de operación del control remoto. (La lámpara de operación no se enciende).	Después de exhibir "startup", parpadea verde (una) y roja(una) alternativamente. <F1>	<ul style="list-style-type: none"> Cableado incorrecto entre las unidades interior y exterior (Polaridad errónea para S1, S2 y S3). Cable de transmisión de control remoto en corto. No hay unidad exterior con dirección 0. (La dirección es diferente de 0). Cable de transmisión de control remoto quemado.
El display aparece pero rápidamente desaparece cuando se opera el control remoto.	Después de exhibir "startup", sólo se enciende la verde. <00>	<ul style="list-style-type: none"> Después de cancelar la selección de función, no es posible la operación por aproximadamente 30 segundos. (Normal)

- Presione dos veces el botón del control remoto (CHECK) para efectuar el autodiagnóstico. Vea la tabla de abajo para los contenidos del display LCD.

LCD	Contenidos del fenómeno inferior	LCD	Contenidos del fenómeno inferior
P1	Anormalidad del termistor de temperatura interior	U1-UP	Falla de la unidad exterior
P2	Anormalidad del termistor de temperatura de cañería de líquido	F3-F9	Falla de la unidad exterior
P4	Anormalidad del sensor de drenaje	E0-E5	Error de transmisión del control remoto
P5	Está trabajando la protección de desborde de drenaje.	E6-EF	Error e comunicación de unidad interior/exterior
P6	Está trabajando la protección de congelado/sobrecalentado.	----	Sin historia de error
P8	Abnormality of pipe temperature	FFFF	Sin unidad aplicada
P9	Anormalidad del termistor de temperatura de cañería de condensador/evaporador		
Fb	Anormalidad de la placa controladora interior		

Vea la tabla de abajo para detalles del display de LED (LED 1, 2, 3) de la placa controladora interior.

LED1 (alimentación de la microcomputadora)	Se enciende cuando hay alimentación
LED2 (Control remoto)	Se enciende cuando se provee alimentación al control remoto cableado. La unidad interior deberá estar conectada a la unidad exterior con dirección "0" configurada.
LED3 (comunicación interior/exterior)	Parpadea cuando las unidades interior y exterior se comunican.

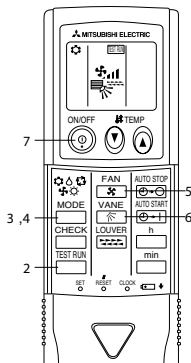

Test run [para control remoto inalámbrico]

Mida una impedancia entre el bloque de terminales de la fuente de alimentación de la unidad exterior y tierra con un megger de 500V y verifique que es igual o mayor a 1,0 MΩ.

- 1 Encienda la alimentación principal de la unidad.
- 2 Presione dos veces consecutivas el botón .
(Inicie esta operación desde el estado del display del control remoto apagado).

Se exhibirá un y el modo actual de operación.

- 3 Presione el botón () para activar el modo , luego verifique si está saliendo aire fresco desde la unidad.
- 4 Presione el botón () para activar el modo , luego verifique si está saliendo aire cálido desde la unidad.
- 5 Presione el botón y verifique si se sopla aire fuerte desde la unidad.
- 6 Presione el botón y verifique si las aletas automáticas operan correctamente.
- 7 Presione el botón ON/OFF para detener el test run.

Nota:

- Apunte al control remoto hacia el receptor de la unidad interior mientras siga los pasos 2 a 7.
- No es posible correrlo en el modo VENTILADOR, SECADO o AUTO.

11-3. COMO PROCEDER CON EL "AUTODIAGNÓSTICO"

11-3-1. Cuando Ocurre un Problema Durante la Operación

Si ocurre un problema en el acondicionador de aire, se detendrán las unidades interior y exterior, y se mostrará el problema en el display del control remoto. Se exhibirán [CHECK] y la dirección del refrigerante en el display de temperatura y el código de error y número de unidad se exhibirán alternadamente como se muestra abajo.

- 1 (si la unidad exterior está fallando, el número de unidad será "00").
- 2 En el caso de control de grupo, para el cual un control remoto controla a sistemas refrigerantes múltiples, la dirección del refrigerante y el código de error de la primera unidad que experimentó el problema será exhibida (por ejemplo la unidad que transmitió el código de error).
- 3 Para borrar el código de error, presione el botón 

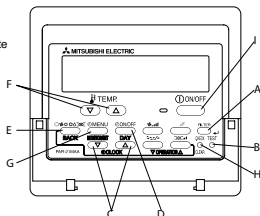

Cuando se usa una operación combinada de de control remoto inalámbrico, cancele el código de error después de apagar la operación del remoto. Durante el control central mediante el control MELANS, cancele el código de error presionando el botón 

11-3-2. Autodiagnóstico Durante Mantenimiento o Servicio



Dado que cada unidad tiene una función que almacena los códigos de error, el último código de verificación puede llamarse aún si es cancelado por el control remoto o se apaga la alimentación.

Verifique la historia de código de error para cada unidad usando el control remoto.

1 Conmute al modo de autodiagnóstico.

H Presione dos veces dentro de los 3 segundos al botón . El display cambiará como se muestra abajo.

2 Configure el número de unidad o dirección de refrigerante que desea diagnosticar.

F Presione los botones [TEMP] () y () para seleccionar el número o dirección deseado. El número (dirección) cambia entre [01] y [50] o [00] y [15].



3 Display de los resultados del autodiagnóstico.

<Cuando hay historia de código de error>

(Para la definición de cada código de error, refiérase al manual de instalación de la unidad interior o el manual de servicio).



<Cuando no hay historia de código de error> <Cuando no hay unidad correspondiente>



4 Reseteo de la historia de error.

Exhibe la historia de errores en la pantalla de exhibición de resultados de diagnóstico (ver el paso 3).

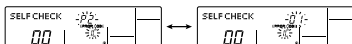

- D Presione dos veces dentro de los tres segundos el botón **(ON/OFF)**. Cuando se resetea la historia de error, el display se verá como el mostrado abajo. Sin embargo, si falla en resetear la historia de error, el contenido de error se volverá a exhibir.



- 5 Cancele al autodiagnóstico.
El autodiagnóstico puede cancelarse por los siguientes dos métodos.
- H Presione dos veces dentro de los tres segundos el botón **(CHECK)** → El autodiagnóstico se cancelará y la pantalla regresará al estado previo en efecto antes de iniciar el autodiagnóstico.
- 5 Presione el botón **(ON/OFF)**. → El autodiagnóstico se cancelará y la unidad interior se detendrá.

11-3-3. Diagnóstico del Control Remoto

Si el acondicionador de aire no puede ser operado desde el control remoto, diagnostique al control remoto como se explica abajo.

- 1 Primero verifique que esté encendido el indicador de alimentación.
Si no se suministra la tensión correcta (12V CC) al control remoto, no se encenderá la lámpara indicadora.
Si ocurre esto, verifique el cableado del control remoto y de la unidad interior.



- 2 Conmute al modo de verificación del control remoto.
H presione el botón **(CHECK)** por cinco o más segundos. el contenido del display cambiará como se muestra abajo.

A Presione el botón **(FILTER)** para iniciar el autodiagnóstico.

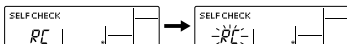

- 3 Resultado del autodiagnóstico del control remoto.
[Cuando el control remoto está funcionando correctamente]

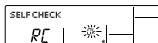

Verifique otras posibles causas dado que no hay problema con el control remoto.

[Cuando el control remoto falla]
(Display de error 1) Parpadea "NG" → El circuito de transmisión/recepción del control remoto está defectuoso.

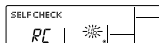

Se debe reemplazar el control remoto por uno nuevo.

[Cuando el control remoto no está defectuoso pero no puede ser operado]
(Código de error 2) [E3] [6833] [6832] parpadea → No es posible la transmisión.

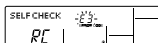

Debe haber ruido o interferencia en la línea de transmisión, o la unidad interior u otro control remoto está defectuoso. Verifique la línea de transmisión y los otros controles remotos.

(Display de error 3) Se exhiben "ERC" y la cantidad de errores de datos → Ha ocurrido un error de datos.



La cantidad de errores de datos es la diferencia entre la cantidad de bits enviada desde el control remoto y la cantidad realmente enviada a través de la línea de transmisión. Si está ocurriendo tal problema, la información enviada es afectada por ruido, etc. Verifique la línea de transmisión.

[E3] Cuando la cantidad de errores de datos es "02":

Datos enviados por el control remoto

Datos enviados a la línea de transmisión



- 4 Para cancelar el diagnóstico del control remoto
H Presione el botón **(CHECK)** durante cinco o más segundos. Se cancelará el diagnóstico del control remoto, "PLEASE WAIT" y la lámpara de operación parpadearán. Aproximadamente 30 segundos después, se restaurará el estado previo a la verificación del control remoto.

3-4. Método de Diagnóstico de Fallas mediante el control remoto INALAMBRICO

<En caso de problemas durante la operación>

Cuando ocurre una falla en el acondicionador de aire, se detendrán ambas unidades interior y exterior y la lámpara de operación parpadeará para indicar una detención inusual.

<Método de diagnóstico de fallas y servicio de mantenimiento>

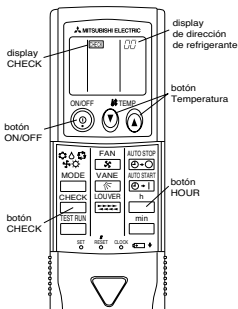

[Procedimiento]

1. Presione dos veces el botón CHECK.
 2. Presione los botones de temperatura \uparrow \downarrow .
 3. Apunte el control remoto hacia el sensor de la unidad interior y presione el botón Hora (h).
 4. Apunte el control remoto hacia el sensor de la unidad interior y presione el botón ON/OFF.
- Se enciende CHECK y parpadea la dirección de refrigerante "00".
 - Verifique que el display del control remoto se haya detenido antes de continuar.
 - Seleccione la dirección de refrigerante de la unidad interior para el auto diagnóstico.
- Nota:** Configure la dirección de refrigerante usando el interruptor dip de la unidad exterior (SW1). (Para mayor información, vea el manual de instalación de la unidad exterior).
- Si ocurre un error del acondicionador de aire, el sensor de la unidad interior emite un zumbido intermitente, parpadea la luz de operación y se exhibe el código de error. (Tarda 3 segundos como máximo en aparecer el código de error).
 - Se cancela el modo de verificación.

- Refiérase a las siguientes tablas para detalles de los códigos de verificación.

[Patrón de salida A]

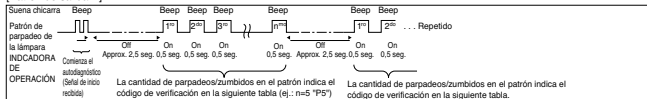

[Patrón de salida B]

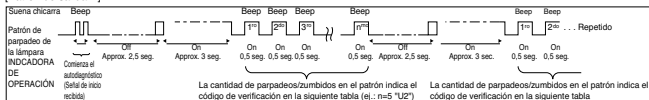

[Patrón de salida A] Errores detectados por la unidad interior

Control remoto inalámbrico	Control remoto cableado	Sintoma	Remark
La chicharra suena/la lámpara de OPERACIÓN paradea (cantidad de veces)	1 Código de verificación		
1	P1	Error del sensor de entrada	Para la unidad interior, refiérase al manual de servicio de la unidad interior.
2	P2	Error de sensor de cañería (TH2)	
	P9	Error de sensor de cañería (TH5)	
3	E6, E7	Error de comunicación interior/externo	
4	P4	Error del sensor de drenaje	
5	P5	Error de la bomba de drenaje	
6	P6	Operación de salvaguarda de Congelado/Sobrecalentado	
7	EE	Error de comunicación entre las unidades interior y exterior	
8	P8	Error de temperatura de cañería	
9	E4, E5	Error de recepción de señal del control remoto	
10	-	-	
11	-	-	
12	Fb	Error de sistema de control de unidad interior (error de memoria, etc.)	
-	E0, E3	Error de transmisión del control remoto	
-	E1, E2	Error de placa de control del control remoto	

[Patrón de salida B] Errores detectados por otra unidad diferente a la unidad interior (unidad exterior, etc.)

Control remoto inalámbrico	Control remoto cableado	Sintoma	Observaciones
La chicharra suena/la lámpara de OPERACIÓN paradea (cantidad de veces)	1 Código de verificación		
1	E9	Error de comunicación interior/externo (Error de transmisión)(Unidad exterior)	Para detalles, verifique el display LED de la placa controladora de la unidad exterior.
2	UP	Interrupción por sobrecorriente en el compresor	
3	U3, U4	Termistores de la unidad exterior abiertos o en corto	
4	UF	Interrupción por sobrecorriente en el compresor(cuando el compresor está bloqueado)	
5	U2	Temperatura de descarga anormalmente alta/acción 49C/ refrigerante insuficiente	
6	U1, Ud	Alta presión anormal (acción 63H)/Operación de salvaguarda de sobrecalentamiento	
7	U5	Temperatura del disipador anormal	
8	U8	Detención de salvaguarda del ventilador de la unidad exterior	
9	U6	Interrupción de sobrecorriente en el compresor/Anormalidad del módulo de alimentación	
10	U7	Anormalidad de sobrecalentamiento debido a baja temperatura de descarga	
11	U9, UH	Anormalidad tal como sobretensión o caída de tensión y señal de sincronismo anormal para el circuito principal/Error del sensor de corriente	
12	-	-	
13	-	-	
14	Otros	Otros errores.	

*1 Si la chicharra no suena nuevamente después de los dos beeps iniciales para confirmar que la señal de inicio de la autoverificación fue recibida y la lámpara del INDICADOR DE OPERACIÓN no se enciende, no hay registros de error.

*2 Si la chicharra suena tres veces continuas "beep, beep, beep (0,4 + 0,4 + 0,4 seg.)" después de los dos beep iniciales para confirmar que se recibió la señal de inicio de la autoverificación, la dirección de refrigerante especificada está incorrecta.

3. Troubleshooting check table

SUZ-KA25VA.TH SUZ-KA35VA.TH
SUZ-KA25VAH.TH SUZ-KA35VAH.TH

Inverter P.C. board (Parts side)

LED
Flashing → ✱NOTE 1. The location of LED is illustrated at the right figure. Refer to 12-6-1.
2. LED lights up during normal operation.

No.	Symptom	LED indication	Abnormal point/ Condition	Detection method	Check point
1	Outdoor unit does not operate	1-time flash every 2.5 seconds	Outdoor power system	When it consecutively occurs 3 times that the compressor stops for overcurrent protection or start-up failure protection within 1minute start-up.	<ul style="list-style-type: none"> Check stop valve. Reconnect connector of compressor. Refer to 12-5.A "How to check inverter/compressor".
2			Outdoor thermistors	When discharge temperature thermistor, fin temperature thermistor or ambient temperature thermistor shorts or opens during compressor running.	Refer to 12-5.G "Check of outdoor thermistors".
3			Outdoor control system	When nonvolatile memory data cannot be read properly, compressor stops.	Replace inverter P.C. board.
4		6-time flash 2.5 seconds OFF	serial signal	When the communication failure between the indoor and outdoor unit for 3 minutes.	Refer to 12-5.O "How to check miswiring and serial signal error.
5		14-time flash 2.5 seconds OFF	Outdoor unit (Other abnormality)	When outdoor unit is defective.	Refer to 12-2-3. Check [output pattern B]
6	'Outdoor unit stops and restarts 3 minutes later' is repeated	2-time flash 2.5 seconds OFF	Overcurrent protection	When 14A(SUZ-KA25VA(H))/ 24A(SUZ-KA35VA(H)) current flows into intelligent power mode.	<ul style="list-style-type: none"> Check stop valve. Reconnect connector of compressor. Refer to 12-5.A "How to check inverter/compressor".
7		3-time flash 2.5 seconds OFF	Discharge temperature overheat protection	When discharge temperature thermistor exceeds 116: compressor stops. Compressor can restart if discharge temperature thermistor reads 100: or less 3 minutes later.	<ul style="list-style-type: none"> Check refrigerant circuit and refrigerant amount. Refer to 12-5.L "Check of LEV".
8		4-time flash 2.5 seconds OFF	Fin temperature P.C. board temperature thermistor overheat protection	When temperature of fin temperature thermistor on the heat sink exceeds 83: (SUZ-KA25VA(H))/ 82: (SUZ-KA35VA(H)) or temperature of P.C. board temperature thermistor exceeds 85: (SUZ-KA25VA(H))/ 81: (SUZ-KA35VA(H)), compressor stops and restarts 3 minutes later.	<ul style="list-style-type: none"> Check around outdoor unit. Check outdoor unit air passage. Refer to 12-5.J "Check of outdoor fan motor".
9		5-time flash 2.5 seconds OFF	High pressure protection	When indoor coil thermistor exceeds 70: in HEAT mode. When the defrost thermistor exceeds 70: in COOL mode.	<ul style="list-style-type: none"> Check refrigerant circuit and refrigerant amount. Check stop valve.
10		8-time flash 2.5 seconds OFF	Compressor synchronous abnormality	When the waveform of compressor current is distorted.	<ul style="list-style-type: none"> Reconnect connector of compressor. Refer to 12-5.A "How to check inverter/compressor".
11		10-time flash 2.5 seconds OFF	Outdoor fan	When outdoor fan has stopped within 30 seconds 3-times a row after outdoor fan start-up, unit stops.	<ul style="list-style-type: none"> Refer to 12-5.J "Check of outdoor fan motor. Refer to 12-5.N "Check of inverter P.C. board.
12		12-time flash 2.5 seconds OFF	Each phase current of compressor	When compressor each phase current cannot be detected normally	Refer to 12-5.A "How to check inverter/compressor".
13		13-time flash 2.5 seconds OFF	DC voltage	When DC voltage of inverter cannot be detected normally.	Refer to 12-5.A "How to check inverter/compressor".
14	Outdoor unit operates	1-time flash 2.5 seconds OFF	Frequency drop by current protection	When current from power outlet exceeds 6.1A(SUZ-KA25VA(H))/ 9.2A(SUZ-KA35VA(H)), compressor frequency lowers.	The unit is normal, but check the following. <ul style="list-style-type: none"> Check if indoor filters are clogged. Check if refrigerant is short. Check if indoor/outdoor unit air circulation is short cycled.
15		3-time flash 2.5 seconds OFF	Frequency drop by high pressure protection	When indoor coil thermistor exceeds 55: in HEAT mode, compressor frequency lowers.	
15			Frequency drop by defrosting in COOL mode	When indoor coil thermistor reads 8: or less in COOL mode, compressor frequency lowers.	
16		4-time flash 2.5 seconds OFF	Frequency drop by discharge temperature protection	When discharge temperature thermistor exceeds 111: compressor frequency lowers.	<ul style="list-style-type: none"> Check refrigerant circuit and refrigerant amount. Refer to 12-5.L "Check of LEV". Refer to 12-5.G "Check of outdoor thermistors".
17	Outdoor unit operates	7-time flash 2.5 seconds OFF	Low discharge temperature protection	When discharge temperature has been 50: or less for 20 minutes.	<ul style="list-style-type: none"> Refer to 12-5.L "Check of LEV". Check refrigerant circuit and refrigerant amount.
18		8-time flash 2.5 seconds OFF	PAM protection	When the overcurrent flows into IGBT (Insulated Gate Bipolar transistor : TR821) or when the bus-bar voltage reaches 320V or more, PAM stops and restarts.	This is not malfunction. PAM protection will be activated in the following cases. <ol style="list-style-type: none"> Instantaneous power voltage drop (Short time power failure) When the power supply voltage is high.
19		9-time flash 2.5 seconds OFF	Inverter check mode	When the connector of compressor is disconnected, inverter check mode starts.	Check if the connector of the compressor is correctly connected. Refer to 12-5.A "How to check inverter/compressor".

The flashing frequency shows the number of times the LED blinks after every 2.5-second OFF.

(Example) When the flashing frequency is "2".

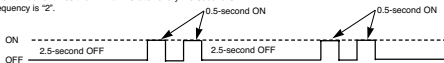

SUZ-KA50VA.TH SUZ-KA60VA.TH SUZ-KA71VA.TH

No.	Symptom	Indication		Abnormal point / Condition	Condition	Correspondence
		LED1(Red)	LED2(Yellow)			
1	Outdoor unit does not operate.	Lightning	Twice	Outdoor power system	When IPM protection stop or lock protection stop is continuously performed three times within 1 minute after the compressor gets started, or when converter protection stop or bus-bar voltage protection stop is continuously performed three times within 3 minutes after start-up.	<ul style="list-style-type: none"> Check the connection of the compressor connecting wire. Refer to 12-5.U "How to check inverter/compressor". Check the stop valve.
2		Lightning	3 times	Discharge temperature thermistor	When a short circuit is detected in the thermistor during operation, or when an open circuit is detected in the thermistor after 10 minutes of compressor start-up.	<ul style="list-style-type: none"> Refer to 12-5.V "Check of outdoor thermistor".
3		Lightning	4 times	Fin temperature thermistor P.C board temperature thermistor	When a short or open circuit is detected in the thermistor during operation.	<ul style="list-style-type: none"> Refer to 12-5.V "Check of outdoor thermistor". Replace the outdoor electronic control P.C. board.
4		Lightning	5 times	Ambient temperature thermistor Outdoor heat exchanger temperature thermistor Defrost thermistor	When a short or open circuit is detected in the thermistor during operation. When a short circuit is detected in the thermistor during operation, or when an open circuit is detected in the thermistor after 5 minutes (in cooling) and 10 minutes (in heating) of compressor start-up. When a short circuit is detected in the thermistor during operation, or when an open circuit is detected in the thermistor after 5 minutes of compressor start-up.	<ul style="list-style-type: none"> Refer to 12-5.V "Check of outdoor thermistor".
5		Lightning	6 times	Serial signal	When the communication fails between the indoor and outdoor unit for 3 minutes.	<ul style="list-style-type: none"> Refer to 12-5.V "How to check mis-wiring and serial signal error".
6		Lightning	7 times	Nonvolatile memory data	When the nonvolatile memory data cannot be read properly.	<ul style="list-style-type: none"> Replace the outdoor electronic control P.C. board.
7		Lightning	8 times	Current sensor	Current sensor protection stop is continuously performed twice.	<ul style="list-style-type: none"> Replace the power board.
8		Lightning	11 times	Communication error between P.C. boards	When the communication protection stop between boards is continuously performed twice.	<ul style="list-style-type: none"> Check the connecting wire between outdoor electronic control P.C. board and power board.
9		Lightning	12 times	Zero cross detecting circuit	The protection stop of the zero cross detecting circuit is continuously performed 10 times.	<ul style="list-style-type: none"> Check the connecting wire among outdoor electronic control P.C. board, noise filter P.C. board and power board.
10	Outdoor unit stops and restarts 3 minutes later is repeated.	Twice	Goes out	IPM protection Lock protection	When over-current is detected after 30 minutes of compressor start-up. When over-current is detected within 30 minutes of compressor start-up	<ul style="list-style-type: none"> Reconnect compressor connector. Refer to 12-5.U "How to check inverter/compressor". Check the stop valve. Check the power module (PAM module).
11		3 times	Goes out	Discharge temperature protection	When temperature of discharge temperature thermistor exceeds 118 °C, compressor stops. Compressor can restart if discharge temperature thermistor reads 100 °C or less 3 minutes later.	<ul style="list-style-type: none"> Check the amount of gas and refrigerant circuit. Refer to 12-5.T "Check of LEV".
12		4 times	Goes out	Fin temperature protection P.C. board temperature protection	When the fin temperature exceeds 87 °C during operation. When the P.C. board temperature exceeds 70 °C during operation.	<ul style="list-style-type: none"> Check refrigerant circuit and refrigerant amount. Refer to 12-5.T "Check of LEV".
13		5 times	Goes out	High-pressure protection	When high-pressure is detected with the high-pressure switch (HPS) during operation. When the outdoor heat exchanger temperature exceeds 70 °C during cooling or when indoor gas pipe temperature exceeds 70 °C during heating.	<ul style="list-style-type: none"> Check amount of gas and the refrigerant circuit. Check of stop valve.
14		8 times	Goes out	Converter protection	When a failure is detected in the operation of the converter during operation.	<ul style="list-style-type: none"> Replace the power board.
15		9 times	Goes out	Bus-bar voltage protection (1) Bus-bar voltage protection (2)	When the bus-bar voltage exceeds 400V or falls to 200V or below during compressor operating. When the bus-bar voltage exceeds 400V or falls to 50V or below during compressor operating.	<ul style="list-style-type: none"> Replace the power board.
16		13 times	Goes out	Outdoor fan motor	When failure occurs continuously three times within 30 seconds after the fan gets started.	<ul style="list-style-type: none"> Refer to 12-5.W "Check of outdoor fan motor".
17		Lightning	9 times	Current sensor protection	When a short or open circuit is detected in the current sensor during compressor operating.	<ul style="list-style-type: none"> Replace the power board.
18		Lightning	11 times	Communication between P.C. boards protection	Communication error occurs between the outdoor electronic control P.C. board and power board for more than 10 seconds.	<ul style="list-style-type: none"> Check the connecting wire between outdoor electronic control P.C. board and power board.
19		Lightning	12 times	Zero cross detecting circuit protection	When zero cross signal cannot be detected while the compressor is operating.	<ul style="list-style-type: none"> Check the connecting wire among outdoor electronic control P.C. board, noise filter P.C. board and power board.

NOTE 1. The location of LED is illustrated at the right figure.
2. LED is lighted during normal operation.

The flashing frequency shows the number of times the LED blinks after every 2.5-second OFF.
(Example) When the flashing frequency is "2".

Outdoor electronic control P.C. board(Parts side)

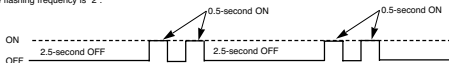

No.	Symptom	Indication		Abnormal point / Condition	Condition	Correspondence
		LED1(Red)	LED2(Yellow)			
20	Outdoor unit operates.	Once	Lighting	Primary current protection	When the input current exceeds 15A.	These symptoms do not mean any abnormality of the product, but check the following points. • Check if indoor filters are clogged. • Check if refrigerant is short. • Check if indoor/outdoor unit air circulation is short cycled.
			Lighting	Secondary current protection	When the current of the compressor exceeds 15A.	
21		Twice	Lighting	High-pressure protection	When the indoor gas pipe temperature exceeds 45: during heating.	• Check if indoor/outdoor unit air circulation is short cycled.
			Lighting	Defrosting in cooling	When the indoor gas pipe temperature falls 3: or below during cooling.	
22		3 times	Lighting	Discharge temperature protection	When the discharge temperature exceeds 100: during operation.	• Check refrigerant circuit and refrigerant amount. • Refer to 12-5.T "Check of LEV". • Refer to 12-5.V "Check of outdoor thermistors".
23		4 times	Lighting	Low discharge temperature protection	When the frequency of the compressor is kept 80Hz or more and the discharge temperature is kept under 39: for more than 20 minutes.	• Refer to 12-5.T "Check of LEV". • Check refrigerant circuit and refrigerant amount.
24		5 times	Lighting	Cooling high-pressure protection	When the outdoor heat exchanger temperature exceeds 58: during operation.	This symptom does not mean any abnormality of the product, but check the following points. • Check if indoor filters are clogged. • Check if refrigerant is short. • Check if indoor/outdoor unit air circulation is short cycled.
25	Outdoor unit operates	9 times	Lighting	Inverter check mode	When the unit is operated with emergency operation switch.	—
26		Lighting	Lighting	Normal	—	—

10-2. SELF-DIAGNOSIS ACTION TABLE

Note: Refer to the manual of outdoor unit for the details of display such as F, U, and other E.

Error Code	Meaning of error code and detection method	Cause	Countermeasure
P1	<p>Abnormality of room temperature thermistor (TH1)</p> <p>1 The unit is in three-minute resume prevention mode if short/open of thermistor is detected. Abnormal if the unit does not reset normally after three minutes. (The unit returns to normal operation, if it has normally reset.)</p> <p>2 Constantly detected during cooling, drying, and heating operation. Short: 90: or more Open: -40: or less</p>	<p>1 Defective thermistor characteristics.</p> <p>2 Contact failure of connector (CN20) on the indoor controller board. (Insert failure)</p> <p>3 Breaking of wire or contact failure of thermistor wiring.</p> <p>4 Defective indoor controller board.</p>	<p>1 -3 Check resistance value of thermistor. 0: -----15.0k" 10: ---9.6k" 20: ---6.3k" 30: ---4.3k" 40: ---3.0k"</p> <p>If you put force on (draw or bend) the lead wire with measuring resistance value of thermistor breaking of wire or contact failure can be detected.</p> <p>2 Check contact failure of connector (CN20) on the indoor controller board. Refer to 10-6. Turn the power on again and check restart after inserting connector again.</p> <p>4 Check room temperature display on remote controller. Replace indoor controller board if there is abnormal difference with actual room temperature.</p> <p>Turn the power off, and on again to operate after check.</p>
P2	<p>Abnormality of pipe temperature thermistor/Liquid (TH2)</p> <p>1 The unit is in three-minute resume prevention mode if short/open of thermistor is detected. Abnormal if the unit does not reset normally after three minutes. (The unit returns to normal operation, if it has normally reset.)</p> <p>2 Constantly detected during cooling, drying, and heating (except defrosting) operation. Short: 90: or more Open: -40: or less</p>	<p>1 Defective thermistor characteristics.</p> <p>2 Contact failure of connector (CN21) on the indoor controller board. (Insert failure)</p> <p>3 Breaking of wire or contact failure of thermistor wiring.</p> <p>4 Defective refrigerant circuit is causing thermistor temperature of 90: or more or -40: or less.</p> <p>5 Defective indoor controller board.</p>	<p>1 -3 Check resistance value of thermistor. For characteristics, refer to (P1) above.</p> <p>2 Check contact failure of connector (CN21) on the indoor controller board. Refer to 10-6. Turn the power on and check restart after inserting connector again.</p> <p>4 Check pipe <liquid> temperature with remote controller in test run mode. If pipe <liquid> temperature is exclusively low (in cooling mode) or high (in heating mode), refrigerant circuit may have defective.</p> <p>5 Check pipe <liquid> temperature with remote controller in test run mode. If there is exclusive difference with actual pipe <liquid> temperature, replace indoor controller board.</p> <p>Turn the power off, and on again to operate after check.</p>
P4	<p>Abnormality of drain sensor (D5)</p> <p>1 Suspensive abnormality, if short/open of thermistor is detected for 30 seconds continuously. Turn off compressor and indoor fan.</p> <p>2 Short/open is detected for 30 seconds continuously during suspensive abnormality. (The unit returns to normal operation, if it has normally reset.)</p> <p>3 Detect the following condition. • During cooling and drying operation. • In case that pipe <liquid> temperature - room temperature <-10deg (Except defrosting) • When pipe <liquid> temperature or room temperature is short/open temperature. • During drain pump operation.</p>	<p>1 Defective thermistor characteristics</p> <p>2 Contact failure of connector (CN31) on the indoor controller board. (Insert failure).</p> <p>3 Breaking of wire or contact failure of drain sensor wiring.</p> <p>4 Defective indoor controller board.</p>	<p>1 -3 Check resistance value of thermistor. 0: -----6.0k" 10: ---3.9k" 20: ---2.6k" 30: ---1.8k" 40: ---1.3k"</p> <p>2 Check contact failure of connector (CN31) on the indoor controller board. Refer to 10-6. Turn the power on again and check restart after inserting connector again.</p> <p>4 Replace indoor controller board if drain pump operates with the line of drain sensor connector CN31-1 and 2 is short-circuited, and abnormality reappears.</p> <p>Turn the power off, and on again to operate after check.</p>
P5	<p>Malfunction of drain pump (DP)</p> <p>1 Suspensive abnormality, if thermistor of drain sensor is let heat itself and temperature rises slightly. Turn off compressor and indoor fan.</p> <p>2 Drain pump is abnormal if the condition above is detected during suspensive abnormality.</p> <p>3 Constantly detected during drain pump operation.</p>	<p>1 Malfunction of drain pump</p> <p>2 Defective drain Clogged drain pump Clogged drain pipe</p> <p>3 Attached drop of water at the drain sensor • Drops of drain trickles from lead wire. • Clogged filter is causing wave of drain.</p> <p>4 Defective indoor controller board.</p>	<p>1 Check if drain-up machine works.</p> <p>2 Check drain function.</p> <p>3 Check the setting of lead wire of drain sensor and check clogs of the filter.</p> <p>4 Replace indoor controller board if drain pump operates with the line of drain sensor connector CN31-1 and 2 is short-circuited and abnormality reappears. Refer to 10-6.</p> <p>Turn the power off, and on again to operate after check.</p>

Error Code	Meaning of error code and detection method	Cause	Countermeasure
P6	<p>Freezing/overheating protection is working</p> <p>1 Freezing protection (Cooling mode) The unit is in six-minute resume prevention mode if pipe <liquid or condenser/evaporator> temperature stays under -15° for three minutes, three minutes after the compressor started. Abnormal if it stays under -15° for three minutes again within 16 minutes after six-minute resume prevention mode. <Frost prevention mode> If pipe <liquid or condenser/evaporator> temperature is 2° or below when 16 minutes has passed after compressor starts operating, unit will start operating in frost prevention mode which stops compressor operation. After that, when pipe <liquid or condenser/evaporator> temperature stays 10° or more for 3 minutes, frost prevention mode will be released and compressor will restart its operation.</p> <p>2 Overheating protection (Heating mode) The unit is in six-minute resume prevention mode if pipe <condenser / evaporator> temperature is detected as over 70° after the compressor started. Abnormal if the temperature of over 70° is detected again within 10 minutes after six-minute resume prevention mode.</p>	<p>(Cooling or drying mode)</p> <ol style="list-style-type: none"> 1 Clogged filter (reduced airflow) 2 Short cycle of air path 3 Low-load (low temperature) operation beyond the tolerance range 4 Defective indoor fan motor <ul style="list-style-type: none"> • Fan motor is defective. • Indoor controller board is defective. 5 Defective outdoor fan control 6 Overcharge of refrigerant 7 Defective refrigerant circuit (clogs) <p>(Heating mode)</p> <ol style="list-style-type: none"> 1 Clogged filter (reduced airflow) 2 Short cycle of air path 3 Over-load (high temperature) operation beyond the tolerance range 4 Defective indoor fan motor <ul style="list-style-type: none"> • Fan motor is defective. • Indoor controller board is defective. 5 Defective outdoor fan control 6 Overcharge of refrigerant 7 Defective refrigerant circuit (clogs) 8 Bypass circuit of outdoor unit is defective. 	<p>(Cooling or drying mode)</p> <ol style="list-style-type: none"> 1 Check clogs of the filter. 2 Remove shields. <p>4 Measure the resistance of fan motor's winding. Measure the output voltage of fan's connector (FAN) on the indoor controller board. When the indoor controller board should be normal when voltage of AC 220~240V is detected while fan motor is connected. Refer to 10-6.</p> <p>5 Check outdoor fan motor.</p> <p>67 Check operating condition of refrigerant circuit.</p> <p>(Heating mode)</p> <ol style="list-style-type: none"> 1 Check clogs of the filter. 2 Remove shields. <p>4 Measure the resistance of fan motor's winding. Measure the output voltage of fan's connector (FAN) on the indoor controller board. When the indoor controller board should be normal when voltage of AC 220~240V is detected while fan motor is connected. Refer to 10-6.</p> <p>5 Check outdoor fan motor.</p> <p>6~8 Check operating condition of refrigerant circuit.</p>
P8	<p>Abnormality of pipe temperature <Cooling mode> Detected as abnormal when the pipe temperature is not in the cooling range 3 minutes later of compressor start and 6 minutes later of the liquid or condenser/evaporator pipe is out of cooling range. Note 1) It takes at least 9 min. to detect. Note 2) Abnormality P8 is not detected in drying mode. Cooling range : -3 deg [(TH-TH1) TH: Lower temperature between: liquid pipe temperature (TH2) and condenser/evaporator temperature (TH5) TH1: Intake temperature</p> <p><Heating mode> When 10 seconds have passed after the compressor starts operation and the hot adjustment mode has finished, the unit is detected as abnormal when condenser/evaporator pipe temperature is not in heating range within 20 minutes. Note 3) It takes at least 27 minutes to detect abnormality. Note 4) It excludes the period of defrosting (Detection restarts when defrosting mode is over) Heating range : 3 deg [(TH5-TH1)</p>	<ol style="list-style-type: none"> 1 Slight temperature difference between indoor room temperature and pipe <liquid or condenser / evaporator> temperature thermistor <ul style="list-style-type: none"> • Shortage of refrigerant • Disconnected holder of pipe <liquid or condenser / evaporator> thermistor • Defective refrigerant circuit 2 Converse connection of extension pipe (on plural units connection) 3 Converse wiring of indoor/outdoor unit connecting wire (on plural units connection) 4 Defective detection of indoor room temperature and pipe <condenser / evaporator> temperature thermistor 5 Stop valve is not opened completely. 	<ol style="list-style-type: none"> 1~4 Check pipe <liquid or condenser / evaporator> temperature with room temperature display on remote controller and outdoor controller circuit board. Pipe <liquid or condenser / evaporator> temperature display is indicated by setting SW2 of outdoor controller circuit board as follows. (Conduct temperature check with outdoor controller circuit board after connecting 'A-Control Service Tool(PAC-SK52ST)') 23 Check converse connection of extension pipe or converse wiring of indoor/outdoor unit connecting wire.

Error Code	Meaning of error code and detection method	Cause	Countermeasure
P9	<p>Abnormality of pipe temperature thermistor / Condenser-Evaporator (TH5)</p> <p>1 The unit is in three-minute resume protection mode if short/open of thermistor is detected. Abnormal if the unit does not get back to normal within three minutes. (The unit returns to normal operation, if it has normally reset.)</p> <p>2 Constantly detected during cooling, drying, and heating operation (except defrosting)</p> <p>Short: 90: or more Open: -40: or less</p>	<p>1 Defective thermistor characteristics</p> <p>2 Contact failure of connector (CN29) on the indoor controller board. (Insert failure)</p> <p>3 Breaking of wire or contact failure of thermistor wiring.</p> <p>4 Temperature of thermistor is 90: or more or -40: or less caused by defective refrigerant circuit.</p> <p>5 Defective indoor controller board.</p>	<p>1 -3 Check resistance value of thermistor. For characteristics, refer to (P1) above.</p> <p>2 Check contact failure of connector (CN29) on the indoor controller board. Refer to 10-6. Turn the power on and check restart after inserting connector again.</p> <p>4 Operate in test run mode and check pipe <condenser / evaporator> temperature with outdoor controller circuit board. If pipe <condenser / evaporator> temperature is exclusively low (in cooling mode) or high (in heating mode), refrigerant circuit may have defective.</p> <p>5 Operate in test run mode and check pipe <condenser / evaporator> temperature with outdoor control circuit board. If there is exclusive difference with actual pipe <condenser / evaporator> temperature replace indoor controller board. There is no abnormality if none of above comes within the unit. Turn the power off and on again to operate.</p> <p>(In case of checking pipe temperature with outdoor controller circuit board, be sure to connect A-control service tool (PAC-SK52ST).)</p>

Error Code	Meaning of error code and detection method	Cause	Countermeasure
E6	Indoor/outdoor unit communication error (Signal receiving error) 1 Abnormal if indoor controller board cannot receive any signal normally for six minutes after putting the power on. 2 Abnormal if indoor controller board cannot receive any signal normally for three minutes. 3 Consider the unit abnormal under the following condition: When two or more indoor units are connected to one outdoor unit, indoor controller board cannot receive a signal for three minutes from outdoor controller circuit board, a signal which allows outdoor controller circuit board to transmit signals.	1 Contact failure, short circuit or mis-wiring (converse wiring) of indoor/outdoor unit connecting wire 2 Defective transmitting receiving circuit of indoor controller board 3 Defective transmitting receiving circuit of indoor controller board 4 Noise has entered into indoor/outdoor unit connecting wire.	* Check LED display on the outdoor control circuit board. (Connect A-control service tool, PAC-SK52ST.) Refer to EA-EC item if LED displays EA-EC. 1 Check disconnection or looseness of indoor/outdoor unit connecting wire of indoor unit or outdoor unit. Check all the units in case of twin triple indoor unit system. 2 -4 Turn the power off, and on again to check. If abnormality generates again, replace indoor controller board or outdoor controller circuit board. * Other indoor controller board may have defective in case of twin triple indoor unit system.
E7	Indoor/outdoor unit communication error (Transmitting error) Abnormal if "1" receiving is detected 30 times continuously though indoor controller board has transmitted "0".	1 Defective transmitting receiving circuit of indoor controller board 2 Noise has entered into power supply. 3 Noise has entered into outdoor control wire.	1 -3 Turn the power off, and on again to check. If abnormality generates again, replace indoor controller board.
Fb	Abnormality of indoor controller board Abnormal if data cannot be normally read from the nonvolatile memory of the indoor controller board.	1 Defective indoor controller board.	1 Replace indoor controller board.

11-4. TABLA DE ACCIÓN DEL AUTODIAGNÓSTICO

<Anormalidades detectadas al dar alimentación>

(Nota 1) Refiérase a la sección de unidad interior para los códigos P y E.

Código de Error	Significado del código de error y método de detección	Causa	Determinación y Acción
Ninguna	-	1 No se provee alimentación al bloque de terminales (TB1) de la unidad exterior. a) Interruptor de alimentación apagado. b) Falta de contacto o desconexión del terminal de alimentación. c) Fase abierta (Fase L o N) 2 No se provee alimentación eléctrica a la placa controladora exterior. a) Falta de contacto en el terminal de alimentación. b) Fase abierta en la placa de alimentación exterior RP35-71V: Desconexión de conectores R o S RP100V-140V: Desconexión del conector TAPT o TABS 3 No se provee alimentación a la placa controladora exterior. a) Desconexión del conector (CNDC) 4 Desconexión del reactor (DCL o ACL) 5 Desconexión de la placa de filtro de ruido exterior o falla de partes en la placa de filtro de ruido exterior. 6 Placa de alimentación exterior defectuosa. 7 Placa controladora exterior defectuosa.	1 Verifique los siguientes ítems. a) Interruptor de alimentación. b) Conexión del bloque de terminales de alimentación (TB1). c) Conexión del bloque de terminales de alimentación (TB1). 2 Verifique los siguientes ítems. a) Conexión del bloque de terminales de alimentación (TB1). b) Conexión del terminal en la placa de alimentación exterior. RP35-71V: Desconexión de conectores R o S. Refiérase a 11-9. RP100-140V: Desconexión de conectores TAPT o TABS. Refiérase a 11-9. 3 Verifique la conexión del conector (CNDC) en el circuito de la de la placa controladora exterior. Verifique la conexión del conector, LD1 y LD2 para RP35-71V y CNDC para RP100-140V, en la placa de alimentación exterior (V) / filtro de ruido (Y). Refiérase a 11-9. 4 Verifique la conexión del reactor. (DCL o ACL) RP35-71V: Verifique la conexión de "L0" y "N0" en la placa de filtro de ruido exterior. RP100-140V: Verifique la conexión de "L1" y "L2" en el módulo de filtro activo. (ACTM) Refiérase a 11-9. 5 a) Verifique la conexión de la placa de filtro de ruido exterior. b) Reemplace la placa de filtro de ruido exterior. Refiérase a 11-9. 6 Reemplace la placa de alimentación exterior. 7 Reemplace la placa controladora (Cuando los ítems de arriba fueron verificados pero la unidad no puede ser reparada).
F3 (5202)	Conector 63L abierto Anormal si el circuito del conector 63L está abierto por tres minutos consecutivos después de encendida la alimentación. 63L: Interruptor de baja presión <sólo PUIHZ-RP100-140VHA, PUHZ-RP125,140VHA, RP100-140YHA>	1 Desconexión o falla de contacto del conector 63L en la placa controladora exterior. 2 Desconexión o falla de contacto de 63L 3 63L está trabajando debido a partes defectuosas. 4 Placa controladora exterior defectuosa.	1 Verifique la conexión del conector 63L en la placa controladora exterior. Refiérase a 11-9. 2 Verifique la conexión del cable del lado de 63L. 3 Verifique la presión del refrigerante. Cargue refrigerante adicional. 4 Verifique la continuidad con un tester. Reemplace las partes que están defectuosas. 4 Reemplace la placa controladora exterior.
F5 (5201)	Conector 63H abierto Anormal si el circuito del conector 63H está abierto por tres minutos consecutivos después de encendida la alimentación. 63H: Interruptor de alta presión	1 Desconexión o falla de contacto del conector 63H en la placa controladora exterior. 2 Desconexión o falla de contacto de 63H 3 63H está trabajando debido a partes defectuosas. 4 Placa controladora exterior defectuosa.	1 Verifique la conexión del conector 63L en la placa controladora exterior. Refiérase a 11-9. 2 Verifique la conexión del cable del lado de 63H. 3 Verifique la continuidad con un tester. Reemplace las partes que están defectuosas. 4 Reemplace la placa controladora exterior.

10-4. SELF-DIAGNOSIS ACTION TABLE

<Abnormalities detected when the power is put on> (Note 1) The number in () is the error cord of upper remote controller (M-NET)

Error Code	Meaning of error code and detection method	Case	Judgment and action
F1 (4103)	Reverse phase detection, Power supply and indoor/outdoor unit connecting wire converse connection 1. Three seconds after power on, judge reverse phase by detecting voltage phase of each phase. 2. Abnormal four minutes after power on if power supply and indoor/outdoor unit connecting wire have converse connection.	1 L1, L2, L3 are not connected correctly. 2 Converse wiring of outdoor power supply line (TB1) and indoor power supply wire (TB4)	1 • Check outdoor power supply connection (TB1) • Replace two phases (for example phase L1 and phase L2) out of three phases of outdoor power supply line (TB1) 2 Check wiring connection.
F2 (4102)	L3-phased open phase detection Detect open phase two seconds after power on.	1 L3-phased open-phase	1 Check power supply.
F7 (4118)	Reverse phase detector circuit (controller board) fault Abnormal if some of each phase detection signal is not input three seconds after power supply.	Defective outdoor controller board	Replace outdoor controller board.
FA (4108)	51CM connector open Abnormal if 51CM connector circuit is open for three minutes continuously after power on. 51CM: Thermal Relay	1 Disconnection or contact failure of 51CM connector on outdoor controller board 2 Disconnection or contact failure of 51CM 3 Defective 51CM (defective parts) 4 Defective outdoor controller	1 Check connecting wire. 2 Check connecting wire. 3 Check continuity by tester. 4 Replace the parts if the parts are defective. 5 Replace outdoor controller board.

Código de Error	Significado del código de error y método de detección	Causa	Determinación y Acción
F9 (4119)	<p>2 conectores abiertos Anormal si ambos conectores 63H y 63L están abiertos por tres minutos consecutivos después de encendida la alimentación.</p> <p>63H: Interruptor de alta presión 63L: Interruptor de baja presión <sólo PUHZ-RP100-140VHA, PUHZ-RP125/140VHA, RP100-140VHA></p>	<p>1 Desconexión o falla de contacto de los conectores 63H y 63L en la placa controladora exterior.</p> <p>2 Desconexión o falla de contacto de 63H y 63L.</p> <p>3 63H y 63L están trabajando debido a partes defectuosas.</p> <p>4 Placa controladora exterior defectuosa.</p>	<p>1 Verifique la conexión de los conectores 63H y 63L en la placa controladora exterior. Refiérase a 12-9.</p> <p>2 Verifique la conexión del cable del lado de 63H y 63L.</p> <p>3 Verifique la continuidad con un tester.</p> <p>4 Reemplace las partes que stán defectuosas.</p> <p>4 Reemplace la placa controladora exterior.</p>
EA (6844)	<p>Falla de conexión del conector interior/ exterior, cantidad excesiva de unidades (4 o más unidades)</p> <p>1. La placa controladora exterior puede verificar automáticamente la cantidad de unidades interior conectadas. Es anormal si la cantidad no puede ser verificada automáticamente debido a fallas de cableado del cable de conexión interior/ exterior, etc. después de 4 minutos de encendida la alimentación.</p> <p>2. Anormal si la placa controladora exterior reconoce que la cantidad de unidades interiores conectadas es de 4 o más.</p>	<p>1 Falla de contacto o mal cableado del cable de conexión interior/ exterior.</p> <p>2 El diámetro o la longitud del cable de conexión interior/exterior está fuera de la capacidad específica.</p> <p>3 Hay conectadas 4 o más unidades interiores a la unidad exterior.</p> <p>4 Circuito de transmisión/recepción de la placa controladora exterior defectuoso.</p> <p>5 Circuito de transmisión/recepción de la placa controladora interior defectuoso.</p> <p>6 Placa de alimentación interior defectuosa.</p> <p>7 Dos o más unidades exteriores tienen la dirección de refrigerante "0". (En caso de control de grupo)</p> <p>8 Ha ingresado ruido en la fuente de alimentación del cable de conexión interior/exterior.</p>	<p>1 Verifique que el cable de conexión interior/ exterior no esté desconectado, flojo o con mala polaridad en las unidades interior/ exterior.</p> <p>2 Verifique el diámetro y la longitud del cable de conexión de las unidades interior/ exterior. Longitud total del cable: 80m (Incluyendo el cableado de conexión de cada unidad interior y entre las unidades interior y exterior) También verifique si el orden de conexión del cable plano es S1, S2, S3.</p> <p>3 Verifique la cantidad de unidades interiores que están conectadas a la unidad exterior. (Si se detecta EA)</p> <p>4-6 Apague y reencienda la alimentación un vez para verificar. Reemplace la placa controladora exterior, la placa controladora interior o la placa de alimentación interior si vuelve a ocurrir la anomalía.</p> <p>7 Verifique si la dirección de refrigerante (SW1-3 a SW1-6 de la placa controladora exterior) se superpone en caso de sistema de control de grupo).</p> <p>8 Verifique el canal de transmisión y remueva las fallas.</p> <p>* La descripción de arriba, 1 - 8, son para EA, Eb y EC.</p>
Eb (6845)	<p>Falta de conexión del cable de conexión entre unidades interior/exterior (Cableado equivocado o desconectado)</p> <p>La placa controladora exterior puede configurar automáticamente el número de unidad de las unidades interior.</p> <p>Es anormal si no se puede configurar los números de unidad interior dentro de los cuatro minutos posteriores al encendido debido a falla de cableado (cableado incorrecto o desconectado) del cable de conexión interior/exterior.</p>	<p>1 Falla de contacto o mal cableado del cable de conexión interior/ exterior.</p> <p>2 El diámetro o la longitud del cable de conexión interior/exterior está fuera de la capacidad específica.</p> <p>4 Circuito de transmisión/recepción de la placa controladora exterior defectuoso.</p> <p>5 Circuito de transmisión/recepción de la placa controladora interior defectuoso.</p> <p>6 Placa de alimentación interior defectuosa.</p> <p>7 Dos o más unidades exteriores tienen la dirección de refrigerante "0". (En caso de control de grupo)</p> <p>8 Ha ingresado ruido en la fuente de alimentación del cable de conexión interior/exterior.</p>	<p>7 Verifique si la dirección de refrigerante (SW1-3 a SW1-6 de la placa controladora exterior) se superpone en caso de sistema de control de grupo).</p> <p>8 Verifique el canal de transmisión y remueva las fallas.</p> <p>* La descripción de arriba, 1 - 8, son para EA, Eb y EC.</p>
EC (6846)	<p>Sobrepasado el tiempo de arranque</p> <p>La unidad no puede terminar el proceso de arranque dentro de los cuatro minutos posteriores al encendido.</p>	<p>1 Falla de contacto o mal cableado del cable de conexión interior/ exterior.</p> <p>2 El diámetro o la longitud del cable de conexión interior/exterior está fuera de la capacidad específica.</p> <p>7 Dos o más unidades exteriores tienen la dirección de refrigerante "0". (En caso de control de grupo)</p> <p>8 Ha ingresado ruido en la fuente de alimentación del cable de conexión interior/exterior.</p>	

<Anormalidades detectadas cuando la unidad está funcionando>

Código de Error	Significado del código de error y método de detección	Causa	Determinación y Acción
U1 (1302)	<p>Alta presión anormal (Funcionó el interruptor de alta presión 63H) Anormal si el interruptor de alta presión 63H se activó (*) durante la operación del compresor. * 4,15 MPa</p> <p>63H: Interruptor de alta presión.</p>	<p>1 Ciclo corto de la unidad interior. 2 Filtro obstruido en la unidad interior. 3 Disminución del flujo de aire causado por suciedad en el ventilador interior. 4 Suciedad en el intercambiador de calor interior. 5 Motor del ventilador interior bloqueado. 6 Falla del motor del ventilador interior. 7 Operación defectuosa de la válvula de retención (No abierta totalmente). 8 Cañería obstruida o rota. 9 Motor del ventilador exterior bloqueado. 10 Falla de la unidad exterior. 11 Ciclo corto de la unidad exterior. 12 Suciedad del intercambiador de calor exterior. 13 Disminución del flujo de aire causado por inspección defectuosa del termistor de temperatura exterior (Detecta una temperatura menor de la real). 14 Desconexión o falla de contacto del conector (63H) en la placa controladora exterior. 15 Desconexión o falla de contacto de la conexión de 63H. 16 Placa controladora exterior defectuosa. 17 Acción defectuosa de la válvula de expansión lineal. 18 Falla del circuito controlador del ventilador.</p>	<p>1-6 Verifique la unidad interior y repare las fallas.</p> <p>7 Verifique si la válvula de retención está totalmente abierta.</p> <p>8 Verifique la cañería y repare los defectos.</p> <p>9-12 Cerifique la unidad exterior y repare los defectos.</p> <p>13 Verifique la temperatura inspeccionada del termistor de temperatura exterior con el display LED. (SW2 en la herramienta de servicio Control A: Refiérase a 11-10).</p> <p>14-16 Apague la alimentación y verifique si se exhibe F5 cuando se reconecta la alimentación. Cuando se exhibe F5, refiérase a Determinación y Acción para F5.</p> <p>17 Verifique la válvula de expansión lineal. Refiérase a 11-6.</p> <p>18 Reemplace la placa controladora exterior o la placa controladora del ventilador.</p>
U2 (1102)	<p>Temperatura de descarga anormal alta (1) Anormal si el termistor de temperatura de descarga (TH4) excede los 125°C o 110°C en forma continua por 5 minutos. Anormal si el termistor de temperatura del condensador/evaporador (TH5) excede los 40°C durante el desescarchado y el termistor de temperatura de descarga (TH4) excede los 110°C.</p> <p>2 Anormal si el sobrecalentamiento de descarga (Refrigeración: TH4 - TH5 / Calefacción: TH4 - TH6) aumenta. Todas las condiciones en A o B son detectadas simultáneamente por 10 minutos continuos después de haber pasado 6 minutos desde el arranque del compresor (incluyendo la indicación del termostato o recuperación desde el desescarchado). <Condición A></p> <ul style="list-style-type: none"> • Modo calefacción • Cuando el sobrecalentamiento de descarga es menor de 70°. • Cuando la temperatura de TH6 es mayor que el valor obtenido por TH7 - 5°. • Cuando la temperatura de condensado de TH5 es menor de 35°C. <p><Condición B></p> <ul style="list-style-type: none"> • Durante la operación del compresor (Refrigeración y Calefacción) • Cuando el sobrecalentamiento de descarga es menor de 80° en refrigeración. • Cuando el sobrecalentamiento de descarga es menor de 90° en calefacción. • Cuando la temperatura de condensado de TH6 es mayor que -40°C. (Sólo en refrigeración). 	<p>1 Operación sobrecalentada del compresor causada por falta de refrigerante. 2 Operación defectuosa de la válvula de retención. 3 Termistor defectuoso. 4 Placa controladora exterior defectuosa. 5 Acción defectuosa de la válvula de expansión lineal.</p>	<p>1 Verifique el sobrecalentamiento de entrada. Verifique pérdidas de refrigerante. Cargue refrigerante adicional.</p> <p>2 Verifique si la válvula de retención está totalmente abierta.</p> <p>3-4 Apague la alimentación y verifique si se exhibe U3 cuando se reconecta la alimentación. Cuando se exhibe U3, refiérase a Determinación y Acción para U3.</p> <p>5 Verifique la válvula de expansión lineal. Refiérase a 11-6.</p>

Error Code	Meaning of error code and detection method	Case	Judgment and action										
U1	<p>Abnormal low current or open phase</p> <ul style="list-style-type: none"> An extreme degradation of current value causes abnormal stop. Abnormal if current detected phase (V-phase) is open phase after first compressor start-up after supplying the power by three phase power supply model. When compressor is operating, compressor is suspended under the following condition: and when current detector (CT) detects a current, which is lower than the detected current specified in the table below, under the following condition: <p><Condition></p> <p>1 For PU/PUH-P71~P100V Current detector (CT) has detected a current, which is lower than the detected current specified in the table below, for 0.7-0.8 second.</p> <p>2 For PU/PUH-P71 ~ P140Y Current detector (CT) has detected a current, which is lower than the detected current specified in the table below, for 0.4-0.5 second.</p> <table border="1"> <thead> <tr> <th>Model</th> <th>Detected current</th> </tr> </thead> <tbody> <tr> <td>P71V</td> <td>2.4 A</td> </tr> <tr> <td>P71Y,P100V,P100Y</td> <td>1.0 A</td> </tr> <tr> <td>P125Y</td> <td>1.2 A</td> </tr> <tr> <td>P140Y</td> <td>1.6 A</td> </tr> </tbody> </table>	Model	Detected current	P71V	2.4 A	P71Y,P100V,P100Y	1.0 A	P125Y	1.2 A	P140Y	1.6 A	<ol style="list-style-type: none"> Shortage of refrigerant Abnormal pressure degradation by pump down operation V-phased open phase of compressor Abnormal compressor Not abnormal if V is instantly displayed when the main power is put off. 	<ol style="list-style-type: none"> Check if refrigerant pressure is not degraded. Check current of compressor operation when abnormality occurred. Check wiring of compressor. Check or replace compressor.
Model	Detected current												
P71V	2.4 A												
P71Y,P100V,P100Y	1.0 A												
P125Y	1.2 A												
P140Y	1.6 A												
U2 (1501)	<p>Abnormal shortage of refrigerant</p> <p>Abnormal if intake super heat exceeds following temperature during heating compressor operation.</p> <p>70: or more, and indoor pipe <condenser- evaporator> temperature (TH5) is 35: or less.</p>	<ol style="list-style-type: none"> Leakage or shortage of refrigerant Defective operation of stop valve (not full open) Defective thermostat (TH4, TH5, TH6) Defective outdoor controller board Defective action of electric expansion valve 	<ol style="list-style-type: none"> Check leakage of refrigerant. Charge refrigerant. Check if stop valve is full open. Put the power off and check if U3 or U4 is displayed when the power is put again. When U3 or U4 is displayed, refer to "Judgement and action" for U3 or U4. Check linear expansion valve. Refer to 10-6 										

Código de Error	Significado del código de error y método de detección	Causa	Determinación y Acción																										
U3 (5104)	Circuito abierto/cerrado del termistor de descarga (TH4) Anormal si, durante la operación del compresor, está abierto (3° o menos) o en corto (217° o más). (La detección no funciona por cinco minutos durante el proceso de arranque del compresor y por 10 minutos después del desescarchado.)	1 Desconexión o falso contacto del conector (TH4) en la placa controladora de la unidad interior 2 Termistor defectuoso 3 Placa controladora de la unidad exterior defectuosa.	1 Verifique la conexión de conector (TH4) en la placa controladora de la unidad exterior. Verifique la rotura del cable del termistor (TH4). Refiérase a 11-9. 2 Verifique la resistencia del termistor (TH4), o la temperatura por microcomputador. (Termistor/TH4: Refiérase a 11-6). (SW2 en la Herramienta de Servicio Control-A: Refiérase a 11-10). 3 Reemplace la placa controladora de la unidad exterior.																										
U4 (TH3:5105) (TH6:5107) (TH7:5106) (TH8:5110)	Circuito abierto/cerrado de los termistores de la unidad exterior (TH3, TH6, TH7 y TH8) Anormal si, durante la operación del compresor, está abierto o en corto. La detección de abierto de los termistores TH3 y TH6 no funciona por 10 segundos a 10 minutos después del arranque del compresor y por 10 minutos después del desescarchado. * Verifique que unidad tiene la anomalía en su termistor conmutando el modo de SW2. (PAC-SK52ST) (Refiérase a 11-10).	1 Desconexión o falso contacto de los conectores. Placa controladora de la unidad exterior: TH3, TH6/TH7 Placa de alimentación exterior: CN3 2 Termistor defectuoso 3 Placa controladora de la unidad exterior defectuosa.	1 Verifique la conexión de conector (TH3, TH32, TH6/TH7) en la placa controladora de la unidad exterior. Verifique la conexión del conector CN3 en la placa de alimentación exterior. Verifique rotura del cable de los termistores (TH3, TH6/TH7). Refiérase a 11-9. 2 Verifique la resistencia del termistor (TH3, TH6/TH7), o verifique la temperatura por microcomputador. (Termistor/TH3, TH6, TH7 y TH8: Refiérase a 11-6). (SW2 en la Herramienta de Servicio Control-A: Refiérase a 11-10). 3 Reemplace la placa controladora de la unidad exterior. * La operación de emergencia está disponible en caso de anomalías de TH3, TH6 y TH7. Refiérase a 11-8.																										
		<table border="1"> <thead> <tr> <th colspan="2">Termistores</th> <th rowspan="2">Detección abierto</th> <th rowspan="2">Detección corto</th> </tr> <tr> <th>Símbolo</th> <th>Nombre</th> </tr> </thead> <tbody> <tr> <td>TH3</td> <td>Termistor <Cañería exterior></td> <td>-40°C o menor</td> <td>90°C o superior</td> </tr> <tr> <td>TH6</td> <td>Termistor <Cañería exterior de 2 fases></td> <td>-40°C o menor</td> <td>90°C o superior</td> </tr> <tr> <td>TH7</td> <td>Termistor <Exterior></td> <td>-40°C o menor</td> <td>90°C o superior</td> </tr> <tr> <td>TH8</td> <td>Termistor <Disipador> PUHZ-RP35-140VHA, RP50-140VHA</td> <td>+27°C o menor</td> <td>102°C o superior</td> </tr> <tr> <td>TH8</td> <td>Termistor interno</td> <td>-35°C o menor</td> <td>170°C o superior</td> </tr> </tbody> </table>		Termistores		Detección abierto	Detección corto	Símbolo	Nombre	TH3	Termistor <Cañería exterior>	-40°C o menor	90°C o superior	TH6	Termistor <Cañería exterior de 2 fases>	-40°C o menor	90°C o superior	TH7	Termistor <Exterior>	-40°C o menor	90°C o superior	TH8	Termistor <Disipador> PUHZ-RP35-140VHA, RP50-140VHA	+27°C o menor	102°C o superior	TH8	Termistor interno	-35°C o menor	170°C o superior
Termistores		Detección abierto	Detección corto																										
Símbolo	Nombre																												
TH3	Termistor <Cañería exterior>	-40°C o menor	90°C o superior																										
TH6	Termistor <Cañería exterior de 2 fases>	-40°C o menor	90°C o superior																										
TH7	Termistor <Exterior>	-40°C o menor	90°C o superior																										
TH8	Termistor <Disipador> PUHZ-RP35-140VHA, RP50-140VHA	+27°C o menor	102°C o superior																										
TH8	Termistor interno	-35°C o menor	170°C o superior																										
U5 (4230)	Anormalidad de temperatura del disipador Anormal si el termistor del disipador TH8, que está incorporado en el módulo de alimentación detecta la temperatura indicada abajo PARA PUHZ: RP35/ 50VHA, RP50VHA: 84°C RP60/ 71VHA, RP60/ 71 VHA: 77°C RP100-140VHA, RP125/ 140VHA: 77°C RP100-140VHA 95°C PARA PUHZ-P100-140VHA 84°C	1 El motor del ventilador exterior está bloqueado. 2 Falla del motor del ventilador exterior. 3 Obstrucción del paso del flujo de aire. 4 Aumento de la temperatura ambiente. 5 Termistor defectuoso 6 Circuito de entrada defectuoso de la placa de alimentación exterior. 7 Falla del circuito de comando del ventilador exterior.	1 2 Verifique el ventilador exterior. 3 Verifique el paso de flujo de aire para refrigeración. 4 Verifique si hay algo que cause el aumento de la temperatura alrededor de la unidad exterior. (Límite superior de temperatura ambiente es 46°C). 5 Apague la alimentación y vuélvala a encender para verificar si se exhibe U5 dentro de los 30 minutos. Si se exhibe U4 en lugar de U5, siga las acciones a seguirse para U4. 6 Verifique la temperatura del termistor (TH8) por la microcomputadora. (Termistor/TH8: Refiérase a 11-6). (SW2 en la Herramienta de Servicio Control-A: Refiérase a 11-10). 7 Reemplace la placa de alimentación exterior. 8 Reemplace la placa controladora exterior.																										
U6 (4250)	Anormalidad del módulo de alimentación Verifique la anomalía controlando el módulo de alimentación en caso de detectar una sobrecorriente. (condición de error UF o UP)	1 Válvula de retención exterior cerrada. 2 Disminución de la tensión de alimentación. 3 Flojedad, desconexión o falla de la conexión del cableado del compresor 4 Compresor defectuoso 5 Placa de circuito de alimentación exterior defectuoso	1 Abra la válvula de retención. 2 Verifique la instalación de la fuente de alimentación. 3 Corrija el cableado (fase U•V•W) del compresor. Refiérase a 11-9 (Placa de alimentación exterior) 4 Verifique al compresor refiriéndose a 11-6. 5 Reemplace la placa de alimentación exterior.																										

Código de Error	Significado del código de error y método de detección	Causa	Determinación y Acción
U7 (1520)	Anormalidad de sobrecalentamiento debido a baja temperatura de descarga. Anormal si el sobrecalentamiento de descarga es detectado en forma continua en 0°C o menos durante tres minutos aunque la válvula de expansión lineal tenga un mínimo pulso de apertura después que el compresor arranque operando por 10 minutos.	<ol style="list-style-type: none"> 1 Desconexión o conexión floja del termistor de temperatura de descarga. (TH4) 2 Soporte defectuoso del termistor de temperatura de descarga. 3 Desconexión o conexión floja de la bobina de la válvula de expansión lineal. 4 Desconexión o conexión floja del conector de la válvula de expansión lineal. 5 Válvula de expansión lineal defectuosa. 	<ol style="list-style-type: none"> 1 2 Verifique las condiciones de instalación del termistor de temperatura de descarga (TH4). 3 Verifique la bobina de la válvula de expansión lineal. Refiérase a 11-7. 4 Verifique la conexión o contacto de la VEL-A y VEL-B en la placa controladora exterior. 5 Verifique la válvula de expansión lineal. Refiérase a 11-6.
U8 (4400)	Anormalidad del motor del ventilador exterior. El motor del ventilador exterior es considerado como anormal si la frecuencia de rotación del motor del ventilador es anormal cuando se detecta durante la operación. La frecuencia de rotación del motor del ventilador es anormal si: <ul style="list-style-type: none"> • Se detecta en forma continua 100 rpm o menor durante 15 segundos a 20°C o mas de temperatura de aire exterior. • Se detecta en forma continua 50 rpm o menor ó 1500 rpm o superior durante 1 minuto. 	<ol style="list-style-type: none"> 1 Falla en la operación del motor de CC del ventilador. 2 Falla en la placa controladora exterior. 	<ol style="list-style-type: none"> 1 Verifique o reemplace el motor de CC. 2 Verifique la tensión de la placa controladora exterior durante la operación. 3 Reemplace la placa controladora exterior. (cuando la falla continúa indicando aun después de efectuar el remedio 1 de arriba).
U9 (4220)	Anormalidad tal como sobretensión o caída de tensión y señal de sincronismo anormal hacia el circuito principal. Anormal si se detecta algo de lo siguiente durante la operación del compresor. <ul style="list-style-type: none"> • Disminución de la tensión de CC del bus a 310V • Disminución de la corriente de entrada de la unidad exterior a 0,5A sólo si la frecuencia de operación es mayor o igual a 40Hz o la corriente del compresor es mayor o igual a 5A. 	<ol style="list-style-type: none"> 1 Disminución en la tensión de alimentación. 2 Desconexión del cableado del compresor. 3 52C defectuoso. 4 Desconexión o conexión floja de CN52C (sólo RP35-71VHA₁) 5 Módulo PFC defectuoso en la placa de alimentación exterior (sólo RP35-71VHA₁) 6 Módulo ACT defectuoso (sólo RP100-140VHA₁) 7 Circuito controlador del módulo ACT de la placa de alimentación exterior defectuoso (sólo RP100-140VHA₁) 8 Desconexión o conexión floja de CNAF (sólo RP100-140VHA₁) 9 Placa del circuito conversor exterior defectuosa (sólo RP100-140YHA) 0 Circuito controlador de 52C de la placa controladora exterior defectuoso (sólo RP35-140VHA₁) 	<ol style="list-style-type: none"> 1 Verifique la instalación de alimentación. 2 Corrija el cableado (fase U-V-W) del compresor. Refiérase a 11-9 (Placa de alimentación exterior) 3 Reemplace 52C. 4 Verifique el cableado de CN52C. 5 Reemplace la placa de alimentación exterior. (sólo RP35-71VHA₁, RP50-71VHA₁) 6 Reemplace el módulo ACT. (sólo RP100-140VHA, RP125/140VHA₁) 7 Reemplace la placa de alimentación exterior. (sólo RP100-140VHA, RP125/140VHA₁) 8 Verifique el cableado CNAF. (sólo RP100-140VHA, RP125/140VHA₁) 9 Reemplace la placa convertidora exterior. (sólo RP100-140YHA) 0 Reemplace la placa controladora exterior. (sólo RP35-140VHA, RP50/140VHA₁) 1 Verifique el cableado CN5 en la placa de alimentación exterior. Refiérase a 11-9. 2 Reemplace la placa de alimentación exterior. (sólo RP100-140YHA) 3 Verifique el cableado CN2 en la placa de alimentación exterior. Refiérase a 11-9.
UF (4100)	Interrupción por sobrecorriente del compresor (Cuando el compresor está bloqueado) Anormal si se detecta una sobrecorriente en el bus de CC o el compresor dentro de los 30 segundos de arrancar la operación del compresor.	<ol style="list-style-type: none"> 1 La válvula de retención está cerrada. 2 Disminución de la tensión de alimentación. 3 Flojedad, desconexión o inversión del cableado de conexión del compresor. 4 Compresor defectuoso. 5 Placa de alimentación exterior defectuosa. 	<ol style="list-style-type: none"> 1 Abra la válvula de retención. 2 Verifique el suministro de energía. 3 Corrija el cableado (fase U+V+W) al compresor Refiérase a 11-9. (Placa de alimentación exterior). 4 Verifique el compresor. Refiérase a 11-6. 5 Reemplace la placa de alimentación exterior.

Error Code	Meaning of error code and detection method	Case	Judgment and action
UA (4101)	Thermal relay (51C) worked Abnormal if 51C is open.	<ol style="list-style-type: none"> 1 Ball valve and stop valve are closed during operation. 2 Abnormal compressor 3 Abnormal power supply voltage 4 Short interruption. 	<ol style="list-style-type: none"> 1 Open ball valve and stop valve. 2 Check or replace compressor. Refer to 5-2. 3, 4 Check power supply voltage.
Ud (1504)	Over heat protection (over-load operation protection/abnormal fan) Abnormal if pipe thermistor detects the value that exceeds set value during compressor operation. P71-P140--70:	<ol style="list-style-type: none"> 1 In cooling mode: defective outdoor fan (fan motor) or short cycle of air path 2 Defective thermistor 3 Defective outdoor controller board 	<ol style="list-style-type: none"> 1 Check outdoor fan (fan motor) Refer to 10-6. 24 Put the power off and operate again to check if U4 is displayed. If U4 is displayed, follow the U4 processing direction.
UE (1302)	Abnormal High pressure This error is detected (4.14MPa) from 63H action within 20 seconds of compressor starting in the first heating mode after power on. 63H: high-pressure switch	<ol style="list-style-type: none"> 1 Gas pipe side ball valve and liquid pipe side stop valve are shut during operation. 2 Disconnection or contact failure of 63H 3 Defective outdoor controller board 4 Power supply reset is detected while indoor filter clogs and overload heating operation. 5 Defective outdoor controller board 6 Defective action of linear expansion valve 	<ol style="list-style-type: none"> 1 Open ball valve and stop valve. 23 Put the power off, and operate again to check if F5 is displayed. If F5 is displayed, follow the F5 processing direction. 4 Check indoor filter. 5 Replace outdoor controller board. 6 Check linear expansion valve. Refer to 10-6.

Código de Error	Significado del código de error y método de detección	Causa	Determinación y Acción
UH (5300)	Error de sensor de corriente Anormal si el sensor de corriente detecta -1,5A a 1,5A durante la operación del compresor. (Este error es ignorado en caso del modo test run)	1 Desconexión del cableado del compresor. 2 Circuito del sensor de corriente de la placa de alimentación exterior defectuoso.	1 Corrija el cableado (fase U•V•W) del compresor. Refiérase a 11-9 (Placa de alimentación exterior). 2 Reemplace la placa de alimentación exterior.
UL (1300)	Baja presión anormal (trabajo 63L) Anormal si se activó 63L (por debajo de 0,03MPa) durante la operación del compresor. 63L: Interruptor de baja presión PARA PUHZ Y PU(H) (RP100-140VHA, RP125-140VHA, RP100-140VHA) PARA PUHZ-P SI: TH7-TH3 ≤ 4°C TH5- TEMP. SALA ≤ 2°C	1 La válvula de retención de la unidad exterior está cerrada durante la operación. 2 Desconexión o conexión floja del conector (63L) en la placa controladora exterior. 3 Desconexión o conexión floja de 63L. 4 Placa controladora exterior defectuosa. 5 Fuga o falta de refrigerante. 6 Falla de la válvula de expansión lineal.	1 Verifique la válvula de retención. 2-4 Apague la alimentación y reenciéndala para verificar si se exhibe F3 al reinicio. Si se exhibe F3, siga las indicaciones de proceso de F3. 5 Corrija la cantidad apropiada de refrigerante. 6 Verifique la válvula de expansión lineal. Refiérase a 11-6
UP (4210)	Interrupción por sobrecorriente del compresor Anormal si se detecta una sobrecorriente en el bus de CC o en el compresor durante 30 segundos después de arrancado el compresor.	1 La válvula de retención de la unidad exterior está cerrada. 2 Caída de la tensión de alimentación. 3 Desconexión, conexión floja o inversión del cableado de conexión del compresor. 4 Ventilador defectuoso de las unidades interior o exterior. 5 Ciclo corto de las unidades interior/exterior. 6 Circuito de entrada de la placa controladora exterior defectuoso. 7 Compresor defectuoso.	1 Abra la válvula de retención. 2 Verifique el suministro de energía. 3 Corrija el cableado (fase U•V•W) del compresor. Refiérase a 11-9 (Placa de alimentación exterior). 4 Verifique los ventiladores interior/exterior. 5 Solucione el ciclo corto. 6 Reemplace la placa controladora exterior. 7 Verifique el compresor. Refiérase a 11-6. * Antes de reemplazar la placa controladora exterior, desconecte el cableado al compresor desde la placa de alimentación exterior y verifique la tensión de salida entre fases, U, V y W durante el test run. No hay falla en la placa si la tensión entre fases (U-V, V-W y W-U) es la misma. Asegúrese de efectuar la verificación de tensión con la misma frecuencia de funcionamiento.
E0 or E4	Error de transmisión del control remoto (E0)/error de recepción de señal (E4) 1 Anormal si el control remoto principal o sub no puede recibir normalmente ninguna transmisión desde la unidad interior de la dirección refrigerante "0" durante tres minutos. (Código de error: E0) 2 Anormal si el control remoto sub no puede recibir ninguna señal durante 2 minutos. (Código de error: E0). 1 Anormal si la placa controladora interior no puede recibir normalmente ninguna información desde la placa del control remoto o desde otra placa controladora interior por tres minutos. (Código de error: E4) 2 La placa controladora interior no puede recibir ninguna señal desde el control remoto por dos minutos. (Código de error: E4).	1 Falla de contacto del cable de transmisión del control remoto. 2 Todos los controles remoto están configurados como "sub" control remoto. En este caso, se exhibe E0 en el control remoto y E4 se exhibe en los LED1 y LED2 de la placa controladora exterior. 3 Error de cableado del control remoto. 4 Circuito de transmisión/recepción del control remoto defectuoso. 5 Circuito de transmisión/recepción de la placa controladora interior de la dirección refrigerante "0" defectuoso. 6 Ha ingresado ruido en el cable de transmisión del control remoto.	1 Verifique la desconexión o conexión floja de la unidad interior o del cable de transmisión del control remoto. 2 Configure uno de los controles remotos como "principal". Si no hay problema con la acción de arriba. 3 Verifique el cableado del control remoto. • Longitud total del cableado: máx. 500m (no utilice cablex 3 o más) • La cantidad de unidades interiores conectadas: máx. 16 unidades. • La cantidad máxima de controles remoto conectados: máx. 2 unidades. Cuando no hay ninguno de los problemas mencionados arriba de 1 a 3 4 Diagnostique los controles remoto. a) Cuando se exhibe "RC OK", El control remoto no tiene problema. Apague la alimentación y reenciéndala. Si se repite la anomalía, reemplace la placa controladora interior. b) Cuando se exhibe "RC NG", Reemplace el control remoto. c) Cuando se exhibe "RC E3". d) Cuando se exhibe "ERC 00-06" [c], d) → El ruido puede estar causando la falla) * Si la unidad no es normal después de reemplazar la placa controladora interior en control de grupo, la placa controladora interior de dirección "0" puede estar anormal.
E1 or E2	Anormalidad de la placa de control del control remoto 1 Anormal si la información no puede ser leída normalmente desde la memoria no volátil de la placa controladora del control remoto. (Código de error: E1) 2 Anormal si la función reloj del control remoto no puede ser operada normalmente. (Código de error: E2)	1 Control remoto defectuoso.	1 Reemplace el control remoto.

Código de Error	Significado del código de error y método de detección	Causa	Determinación y Acción
E3 or E5	Error de transmisión del control remoto (E3) (Error de recepción de señal (E5)) 1 Anormal si el control remoto no puede encontrar un blanco en el canal de transmisión por seis segundos y no puede transmitir. (Código de error: E3) 2 El control remoto recibe información transmitida al mismo tiempo, compara la información y cuando la detecta, determina que la información diferente es anormal 30 veces consecutivas. (Código de error: E3) 1 Anormal si la placa controladora interior no puede encontrar un blanco en el canal de transmisión. (Código de error: E5) 2 La placa controladora interior recibe información transmitida al mismo tiempo, compara la información y cuando la detecta, determina que la información diferente es anormal 30 veces consecutivas. (Código de error: E5)	1 Dos controles remotos están configurados como "principal". (en caso de 2 controles remotos) 2 El control remoto está conectado con dos o más unidades interiores. 3 Dirección refrigerante repetida. 4 Circuito de transmisión/recepción del control remoto defectuoso. 5 Circuito de transmisión/recepción de la placa controladora interior defectuoso. 6 Ha ingresado ruido en el cable de transmisión del control remoto.	1 Configure un control remoto como "principal" y el otro como "sub". 2 El control remoto está conectado con una sola unidad interior. 3 La dirección cuba a una configuración separada. 4-6 Diagnostique los controles remotos. a) Cuando se exhibe "RC OK", El control remoto no tiene problema. Apague la alimentación y reenciéndala. Si se repite la anomalía, reemplace la placa controladora interior. b) Cuando se exhibe "RC NG". Reemplace el control remoto. c) Cuando se exhibe "RC E3". d) Cuando se exhibe "ERC 00-06" [c], d) → El ruido puede estar causando la falla * Si la unidad no es normal después de reemplazar la placa controladora interior en control de grupo, la placa controladora interior de dirección "0" puede estar anormal.
E8 (6840)	Error de comunicación de unidad interior/exterior (Error de recepción de señal) (Unidad exterior) 1 Anormal si la placa controladora exterior no puede recibir nada normalmente durante tres minutos.	1 Falla de contacto del cable de conexión interior/exterior. 2 Circuito de comunicación de la placa controladora exterior defectuoso. 3 Circuito de comunicación de la placa controladora interior defectuoso. 4 Ha ingresado ruido en el cable de conexión interior/exterior.	1 Verifique desconexión o conexión floja del cable de conexión entre las unidades interior/exterior. 2-4 Apague y reencienda la alimentación. Reemplace la placa controladora interior o exterior si se vuelve a exhibir la anomalía.
E9 (6841)	Error de comunicación de unidad interior/exterior (Error de transmisión de señal) (Unidad exterior) 1 Anormal si se recibe "0" 30 veces continuas a pesar que la placa controladora exterior haya transmitido "1". 2 Anormal si la placa controladora exterior no puede encontrar un espacio en el canal de transmisión durante tres minutos.	1 Falla de contacto del cable de conexión interior/exterior. 2 Circuito de comunicación de la placa controladora exterior defectuoso. 3 Ha ingresado ruido en la alimentación. 4 Ha ingresado ruido en el cable de conexión interior/exterior.	1 Verifique desconexión o conexión floja del cable de conexión entre las unidades interior/exterior. 2-4 Apague y reencienda la alimentación. Reemplace la placa controladora exterior si se vuelve a exhibir la anomalía.
EF (6607 or 6608)	Error no definido Se exhibe este código cuando se recibe un error no definido.	1 Ha ingresado ruido en el cable de transmisión del control remoto. 2 Ha ingresado ruido en el cable de conexión interior/exterior. 3 La unidad exterior no es de una serie de inversor de potencia. 4 El modelo del control remoto es PAR-S25A.	1-2 Apague y reencienda la alimentación. Reemplace la placa controladora interior si se vuelve a exhibir la anomalía. 3 Reemplace la unidad interior por una del tipo inversor de potencia. 4 Reemplace el control remoto por un del tipo MA.
Ed (0403)	Error de comunicación serie 1 Anormal si la comunicación serie entre la placa controladora exterior y la placa de alimentación exterior es defectuosa. 2 Anormal si la comunicación serie entre la placa controladora exterior y la placa M-NET no está disponible.	1 Rotura de cable o falla de contacto del conector CN2 entre la placa controladora exterior y la placa de alimentación exterior. 2 Rotura de cable o falla de contacto del conector CN4 entre la placa controladora exterior y la placa de alimentación exterior. 3 Circuito de comunicación de la placa de alimentación exterior defectuoso. 4 Circuito de comunicación entre la placa controladora exterior y la placa de alimentación exterior defectuoso.	1-2 Verifique la conexión de cada conector CN2 y CN4 entre la placa controladora exterior y la placa de alimentación exterior. 3 Reemplace la placa de alimentación exterior. 4 Reemplace la placa controladora exterior.
		1 Rotura de cable o falla de contacto entre la placa controladora exterior y la placa M-NET. 2 Falla de contacto de la línea de alimentación de la placa M-NET. 3 Ha ingresado ruido en el cable de transmisión M-NET.	1 Verifique desconexión, conexión floja o rotura del cable de conexión entre la placa controladora exterior (CNMNT) y la placa M-NET (CN5). 2 Verifique desconexión, conexión floja o rotura del cable de conexión entre la placa controladora exterior (CNMNT) y la placa M-NET (CND). 3 Verifique el método de cableado de transmisión M-NET.

Código de Error	Significado del código de error y método de detección	Causa	Determinación y Acción
A6 (6606)	Error de comunicación con el procesador de comunicación Comunicación defectuosa entre el procesador de la unidad y el procesador de transmisión. Nota: La dirección y atributo exhibido en el control remoto indica al controlador que detectó la anomalía.	<ol style="list-style-type: none"> 1 La información del procesador de transmisión o procesador de la unidad no es transmitida normalmente debido a un problema accidental tal como un transitorio o trueno. 2 La dirección que envía desde el procesador de la unidad no es transmitida normalmente debido a un defecto en el hardware del procesador de transmisión. 	<p>Apague la alimentación de las unidades exterior, interior FRESH MASTER y LOSSNAY al mismo tiempo por dos o más minutos y vuelva a conectar la alimentación. El sistema regresa a la normalidad si la anomalía fue una falla accidental.</p> <p>Si se vuelve a generar la anomalía, el controlador generador de la anomalía puede estar defectuoso.</p>
A7 (6607)	Sin señal ACK (Confirmación) <ol style="list-style-type: none"> 1 El lado transmisor del controlador detecta la anomalía cuando se transmitió un mensaje pero no hay respuesta (ACK) de que el mensaje fue recibido. El lado transmisor detecta la anomalía cada 30 segundos, seis veces consecutivas. <p>Nota: La dirección/Atributo exhibida en el control remoto muestra al controlador que no respondió (ACK).</p>	<p>Factor que no está relacionado con el origen de la anomalía</p> <ol style="list-style-type: none"> 1 La unidad de la primera dirección no existe debido a que el interruptor de la dirección fue cambiado con la unidad encendida. 2 Caída de la tensión de la señal de transmisión por sobrepaso de la tolerancia de la línea de transmisión. <ul style="list-style-type: none"> • El punto más lejano 200m • Línea del control remoto (12m) 3 Caída de la tensión de la línea de transmisión y señal por diferente tipo de línea. <p>Tipo</p> <p>Línea blindada CVVS, CPEVS Con cable normal (sin blindaje)-VCTF, VCTFK, CVV, CVS, VVR, VVF, VCT</p> <p>Sección de línea 1,25 mm² o mayor</p> 4 Caída de la tensión de transmisión y señal por un exceso de unidades conectadas. 5 Falla de operación del controlador de origen, que ocurre por casualidad. (ruido, trueno) 6 Controlador de origen defectuoso. 	<p>Siempre pruebe lo siguiente cuando ocurre el error "A7".</p> <ol style="list-style-type: none"> 1 Apague la alimentación de las unidades exterior, interior, fresh master y lossnay por dos minutos o más al mismo tiempo. Luego, encienda la alimentación. Si la falla que ocurrió por casualidad se recupera normalmente. 2 Verifique el interruptor de dirección en la dirección en la cual ocurrió la anomalía. 3 Verifique si la línea de transmisión está conectada o floja en el origen. (Bloque de terminales y conector) 4 Verifique si la tolerancia de la línea de transmisión no está excedida. 5 Verifique si el tipo de línea de transmisión es correcta o no. <p>Cuando hay un problema de los puntos de arriba 1 a 5, apague la alimentación de la unidad exterior, interior y lossnay por 2 minutos o más al mismo tiempo y luego encienda la alimentación.</p> <ul style="list-style-type: none"> • Si no hay ningún problema de los 1 a 5 de arriba, en el sistema refrigerante simple (1 unidad exterior) el controlador de la dirección y atributo exhibido está defectuoso. • Cuando no hay ningún problema de los 1 a 5 de arriba en un sistema refrigerante diferente (2 o más unidades exteriores) determinelo desde 6. <p>6 Si la dirección de la fuente de anomalía es la dirección que no debería existir hay una unidad que memoriza la información de dirección inexistente. Elimine la información de la dirección innecesaria mediante la función de configuración manual del control remoto. Sólo los sistemas FRESH MASTER o LOSSNAY están conectados a, o el sistema que es equipado con configuración de grupo de diferentes sistemas refrigerantes.</p> <p>Cuando no hay problemas del 1 al 6 de arriba, reemplace la placa controladora cuya dirección/ atributo se exhibe.</p> <p>Si el error no se recupera a normal, la placa controladora multi de la unidad exterior (circuito repetidor) debe ser considerada como defectuosa.</p> <p>Reemplazando de a una las placas controladoras multi para verificar si la unidad se normaliza.</p>
	<ol style="list-style-type: none"> 2 Si la dirección o atributo exhibido es la unidad exterior, La unidad interior detecta la anomalía cuando le transmite a la unidad exterior y no recibe respuesta (ACK). 	<ol style="list-style-type: none"> 1 Falla de contacto del cable de transmisión de la unidad exterior o interior. 2 Desconexión del conector de transmisión (CN2M) de la unidad exterior. 3 Circuito de transmisión/ recepción defectuoso de la unidad exterior o interior. 	
	<ol style="list-style-type: none"> 3 Si la dirección o atributo exhibido es la unidad interior, El control remoto detecta la anomalía cuando le transmite a la unidad interior y no recibe respuesta (ACK). 	<ol style="list-style-type: none"> 1 Durante la operación de grupo con una unidad interior de sistema refrigerante múltiple, si el control remoto transmite a la unidad interior mientras que la alimentación de la unidad exterior de un sistema refrigerante se apaga o está dentro de los dos minutos de arranque, se detecta la anomalía. 2 Falla de contacto del cable de transmisión del control remoto o de la unidad interior. 3 Desconexión del conector de transmisión (CN2M) de la unidad interior. 4 Circuito de transmisión/ recepción defectuoso de la unidad interior o del control remoto. 	

Continúa en la próxima página

Desde la página anterior.

Código de Error	Significado del código de error y método de detección	Causa	Determinación y Acción
A7 (6607)	4. Si la dirección / atributo exhibidos es el control remoto. La unidad interior detecta la anomalía cuando la unidad interior transmite al control remoto y no hay respuesta (ACK).	<ol style="list-style-type: none"> Durante la operación de grupo con unidad interior y sistema multi-refrigerante, si la unidad interior transmite al control remoto mientras la alimentación de la unidad exterior del mismo sistema refrigerante con es apagada o dentro de los dos minutos de arranque, se detecta la anomalía. Falla de contacto de la línea de transmisión de la unidad interior o control remoto. Desconexión del conector de transmisión (CN2M) de la unidad interior. Falla del circuito de transmisión/recepción de la unidad interior o control remoto. 	Lo mismo que los mencionados de "A7" en la página anterior.
	5. Si la dirección / atributo exhibidos es FRESH MASTER La unidad interior detecta la anomalía cuando la unidad interior transmite al FRESH MASTER y no hay respuesta (ACK).	<ol style="list-style-type: none"> Durante la operación secuencial de la unidad interior y el FRESH MASTER de otro sistema refrigerante, si la unidad interior transmite al FRESH MASTER mientras la alimentación de la unidad exterior del mismo sistema refrigerante con FRESH MASTER es apagada o dentro de los dos minutos de arranque, se detecta la anomalía. Falla de contacto de la línea de transmisión de la unidad interior o FRESH MASTER. Desconexión del conector de transmisión (CN2M) de la unidad interior o FRESH MASTER. Falla del circuito de transmisión/recepción de la unidad interior o FRESH MASTER. 	
	6. Si la dirección / atributo exhibidos es LOSSNAY La unidad interior detecta la anomalía cuando la unidad interior transmite al LOSSNAY y no hay respuesta (ACK).	<ol style="list-style-type: none"> Si la alimentación del LOSSNAY está apagada, la unidad interior detecta la anomalía cuando le transmite al LOSSNAY. Durante la operación secuencial de la unidad interior y LOSSNAY de otro sistema refrigerante, si la unidad interior transmite al LOSSNAY mientras que la alimentación de la unidad exterior del mismo sistema refrigerante del LOSSNAY es apagada o está dentro de los dos minutos de arranque, se detecta la anomalía. Falla de contacto del cable de transmisión de la unidad interior del LOSSNAY. Desconexión del conector de transmisión (CN2M) de la unidad interior. Circuito de transmisión/recepción defectuoso de la unidad interior o LOSSNAY. 	
7. Si la dirección / atributo exhibidos no existe.	<ol style="list-style-type: none"> La unidad de la primera dirección no existe debido a que el interruptor de direcciones ha cambiado mientras la unidad estaba energizada. Se detecta la anomalía cuando la unidad interior transmitió debido a que la dirección de FRESH MASTER y LOSSNAY son cambiadas después de la operación secuencial del FRESH MASTER y LOSSNAY por el control remoto. 		

Código de Error	Significado del código de error y método de detección	Causa	Determinación y Acción
<p>A8 (6608)</p>	<p>SIN RESPUESTA DE M-NET Anormal si se transmite un mensaje y hubo una respuesta que el mensaje fué recibido pero el comando de respuesta no regresa. El lado transmisor detecta la anomalía cada 30 segundos, seis veces consecutivas. Nota: La dirección y atributo exhibidos en el control remoto indican al controlador que no respondió (ACK).</p>	<p>1 La condición de transmisión repite la falta debido a ruido o similar. 2 El cable de transmisión excede las distancias máximas permitidas para la línea. • Distancia máxima: 200m • Línea de control remoto: 12m 3 El cable de transmisión no es del tipo de cable de transmisión. Tipo Con cable blindado CVVS, CPEVS Con cable normal (no blindado) VCTF, VCTFK, CVV, CVS, VVR, VVF, VCT Diámetro: 1,25 mm² o superior 4 Falla accidental generada por el controlador.</p>	<p>1 Verifique la forma de onda de transmisión o ruido en la línea de transmisión. 2 Apague la alimentación de las unidades exterior, interior FRESH MASTER y LOSSNAY al mismo tiempo por dos o más minutos y vuelva a conectar la alimentación. El sistema regresa a la normalidad si la anomalía fué una falla accidental. Si se vuelve a generar la anomalía, el controlador generador de la anomalía puede estar defectuoso.</p>

<Función de exhibición de inspección para la unidad exterior>

Los patrones de parpadeo para ambos LED1(verde) y LED2(rojo) indica los tipos de anomalía cuando esta ocurre. Los tipos de anomalía pueden ser indicados en detalles conectando una parte opcional "Herramienta de Servicio Control-A" (PAC-SK52ST) al conector CNM de la placa controladora exterior.

[Display]

(1) Condición normal

Condición de unidad	Placa controladora exterior		Herramienta de Servicio Control-A	
	LED1 (Verde)	LED2 (Rojo)	Código de error	Indicación en el display
Con alimentación encendida	Encendido	Encendido	-- ↔ --	Display parpadeando alternativamente
Cuando se detiene la unidad	Encendido	Apagado	00, etc.	Modo de operación
Cuando se está calentando el compresor	Encendido	Apagado	08, etc.	
Cuando la unidad opera	Encendido	Encendido	C5, H7 etc.	

(2) Condición anormal

Indicación		Error				
Placa controladora exterior		Contenido	Código de error *1	Método de inspección	Página de referencia detallada	
LED1 (Verde)	LED2 (Rojo)					
1 parpadeo	2 parpadeos	Conector(63L) abierto.	F3	1 Verifique si el conector (63L o 63H) en la placa controladora exterior no está desconectado. 2 Verifique la continuidad del interruptor de presión (63L o 63H) con un tester	P.36	
		Conector(63H) abierto.	F5		P.36	
		2 conectores abiertos.	F9		P.37	
2 parpadeos	1 parpadeo	Mal cableada la conexión de unidades interior/exterior. Excesiva cantidad de unidades interiores (5 o más unidades)	-	1 Verifique si el cable de conexión interior/exterior está bien conectado. 2 Verifique si hay conectadas 5 o más unidades interiores a la unidad exterior. 3 Verifique si entró ruido en el cable de conexión interior/exterior o en la alimentación. 4 Revérifícelo el error apagando y reencendiendo la alimentación.	P.37 (EA)	
		Mal cableada la conexión de unidades interior/exterior (Cable invertido o desconectado)	-		P.37 (Eb)	
		Sobrepaso del tiempo de arranque	-		P.29 (EC)	
	2 parpadeos	2 parpadeos	Error de comunicación interior/exterior (error de recepción de señal) detectado por la unidad interior.	E6	1 Verifique si el cable de conexión interior/exterior está bien conectado. 2 Verifique si entró ruido en el cable de conexión interior/exterior o en la alimentación. 3 Verifique si entró ruido en la placa controladora interior/exterior. 4 Revérifícelo el error apagando y reencendiendo la alimentación.	*2
			Error de comunicación interior/exterior (error de transmisión) detectado por la unidad interior.	E7		*2
			Error de comunicación interior/exterior (error de recepción de señal) detectado por la unidad exterior.	-		P.42 (E8)
Error de comunicación interior/exterior (error de transmisión) detectado por la unidad exterior.			-	P.33 (E9)		
3 parpadeos	3 parpadeos	Error de recepción de señal del control remoto detectado por el control remoto.	E0	1 Verifique si el cable de conexión de la unidad interior y el control remoto está bien conectado. 2 Verifique si ingresó ruido en el cable de transmisión del control remoto. 3 Revérifícelo el error apagando y reencendiendo la alimentación.	P.41	
		Error de transmisión del control remoto detectado por el control remoto.	E3		P.42	
		Error de recepción de señal del control remoto detectado por la unidad interior.	E4		P.41	
		Error de transmisión del control remoto detectado por la unidad interior.	E5		P.42	
4 parpadeos	4 parpadeos	Código de error no definido.	EF	1 Verifique si el control remoto es un control remoto MA (PAR-21MAA). 2 Verifique si ingresó ruido en el cable de transmisión del control remoto. 3 Verifique si ingresó ruido en el cable de conexión entre las unidades interior/exterior. 4 Revérifícelo el error apagando y reencendiendo la alimentación.	P.42	
5 parpadeos	5 parpadeos	Error de comunicación serie <Comunicación entre la placa controladora exterior y la placa de alimentación exterior-> <Comunicación entre la placa controladora exterior y la placa M-NET>	Ed	1 Verifique si el conector (CN4) en la placa controladora exterior y placa de alimentación exterior no está desconectado. 2 Verifique si hay una conexión pobre del conector en la placa controladora exterior (CNMNT y CNVMNT). 3 Verifique la señal de comunicación M-NET.	P.42	
		Error de comunicación de señal de alta prioridad (M-NET)	A0-A8		P.43~	
					P.46	

*1. El control remoto exhibe el código de error.

*2. Refiérase al manual de servicio para la unidad interior.

Indicación		Error			
Placa controladora exterior	Contenido	Código de error *	Método de inspección	Página de referencia detallada	
LED1 (Verde)	LED2 (Rojo)				
3 parpadeos	Anormalidad del termostato de carcasa y temperatura de descarga (TH4)	U2	1 Verifique si las válvulas de retención están abiertas. 2 Verifique si los conectores (TH4, VEL-A y VEL-B) de la placa controladora exterior no están desconectados.	P.38	
		U7	3 Verifique si la unidad está llena con la cantidad específica de refrigerante. 4 Mida los valores de resistencia entre terminales en la válvula interior y la válvula de expansión lineal exterior usando un tester.	P.40	
	2 parpadeos	Anormalidad de alta presión (Se accionó el interruptor de alta presión 63H)	U1	1 Verifique si las unidades interior/exterior tienen ciclos cortos en sus ductos de aire. 2 Verifique si el conector (63H) en la placa controladora exterior no está desconectado. 3 Verifique si el intercambiador de calor y el filtro no están sucios. 4 Mida los valores de resistencia entre los terminales de la válvula de expansión lineal usando un tester.	P.38
			U8	1 Verifique el motor del ventilador exterior.	P.40
	4 parpadeos	Corte por sobrecorriente del compresor (Biquzo de arranque) Corte por sobrecorriente del compresor Anormalidad del sensor de corriente (P.B.) Anormalidad del módulo de alimentación	UF	1 Verifique si las válvulas de retención están abiertas.	P.40
			UP	2 Verifique fiabilidad, desconexión y conexión invertida del cableado del compresor.	P.41
			UH	3 Mida los valores de resistencia entre los terminales del compresor usando un tester.	P.41
			U6	4 Verifique si la unidad exterior tiene un ciclo corto en su ducto de aire.	P.39
	5 parpadeos	Termistor de descarga en corto/abierto (TH4) Termistores exteriores en corto/abiertos (TH3, TH6, TH7 y TH8) Termistor exterior en corto/abierto (TH8)	U3	1 Verifique si los conectores (TH3, TH4, TH6 y TH7) en la placa controladora exterior y el conector (CN3) de la placa de alimentación exterior no están desconectados.	P.39
			U4	2 Mida los valores de resistencia de los termistores exteriores.	P.39
U5			1 Verifique si las unidades interior/exterior no tienen un ciclo corto en sus ductos de aire. 2 Mida el valor de resistencia del termistor exterior (TH8).	P.39	
6 parpadeos	Anormalidad de temperatura del disipador	U5	1 Verifique si las unidades interior/exterior no tienen un ciclo corto en sus ductos de aire. 2 Mida el valor de resistencia del termistor exterior (TH8).	P.39	
7 parpadeos	Anormalidad de tensión	U9	1 Verifique fiabilidad, desconexión y conexión invertida del cableado del compresor. 2 Mida los valores de resistencia entre los terminales del compresor usando un tester. 3 Verifique la continuidad del contactor (52C). 4 Verifique si la tensión de alimentación disminuye. 5 Verifique el cableado de CN52C. 6 Verifique el cableado de CNAF.	P.40	
4 parpadeos	Anormalidad del sensor de temperatura ambiente (TH1) Anormalidad del sensor de temperatura de cañería de líquido (TH2) Anormalidad del sensor de temperatura de cañería de condensador- evaporador	P1	1 Verifique si los conectores (CN20, CN21 y CN29) de la placa controladora interior no están desconectados.	W2	
		P2	2 Mida el valor de resistencia de los termistores interiores.	W2	
		P9		W2	
	2 parpadeos	Anormalidad del sensor de drenaje (DS) Protección de desborde de drenaje interior	P4	1 Verifique si el conector (CN31) de la placa controladora interior no está desconectado.	W2
			P5	2 Mida el valor de resistencia de los termistores interiores. 3 Mida el valor de resistencia entre los terminales de la bomba de drenaje usando un tester. 4 Verifique si funciona la bomba de drenaje. 5 Verifique la función de drenaje.	W2
	3 parpadeos	Protección de congelado (refrigeración) y sobrecalentamiento (calefacción)	P6	1 Verifique si la unidad interior tiene un ciclo corto en su ducto de aire. 2 Verifique si el intercambiador de calor y filtro no están sucios. 3 Mida el valor de resistencia en los motores de los ventiladores interior y exterior. 4 Verifique si el interior de la cañería de refrigerante no está obstruido.	W2
	4 parpadeos	Anormalidad de temperatura de cañería	P8	1 Verifique si los termistores interiores (TH2 y TH5) no están desconectados del soporte. 2 Verifique si la válvula de retención está abierta. 3 Verifique si no está invertida la conexión de la cañería de extensión. (En conexión de unidades múltiples) 4 Verifique que el cable de conexión interior/exterior esté correctamente conectado. (En conexión de unidades múltiples)	W2

*1. El control remoto exhibe el código de error.

*2. Refiérase al manual de servicio para la unidad interior.

Síntoma: Se mantiene exhibido en el control remoto el mensaje "PLEASE WAIT"

Flujo de diagnóstico	Causa	Método de inspección y búsqueda de errores
<pre> graph TD Start[Después de encender la alimentación principal verifique el tiempo que se exhibe "PLEASE WAIT".] --> D1{¿Cuanto tiempo se mantiene "PLEASE WAIT" en el display?} D1 -- "2 a 6 minutos" --> D2{¿Hay algún código de error exhibido en el display?} D1 -- "6 o más minutos" --> Causa D1 -- "2 o menos minutos" --> Causa D2 -- "SI" --> Causa D2 -- "NO" --> LED[Verifique el display LED de la placa controladora exterior.] LED --> D3{¿Hay algún código de error exhibido en el display?} D3 -- "SI" --> Causa D3 -- "NO" --> D1 </pre>	<ul style="list-style-type: none"> • Se exhibirá "PLEASE WAIT" durante el diagnóstico de arranque después de encender la alimentación principal. • Mal cableado del cable de conexión interior/exterior. • Rotura del cable de conexión interior/exterior (S3) • Placa controladora interior defectuosa. • Placa controladora exterior defectuosa. • Placa controladora interior defectuosa. • Control remoto defectuoso. 	<ul style="list-style-type: none"> • Normal. El diagnóstico de arranque finalizará en aproximadamente 2 minutos. • Refiérase a "Tabla de acción de autodiagnóstico" para resolver el problema. • En caso de errores de comunicación, el display del control remoto puede no coincidir con el display LED de la unidad exterior.

Síntoma: No se exhibe nada en el control remoto.**1**

Display LED de la placa controladora interior.
 LED1 : ○
 LED2 : ○
 LED3 : ○





Flujo de diagnóstico	Causa	Método de inspección y búsqueda de errores
<p>Verifique que la tensión entre S1 y S2 en el bloque de terminales (TB4) de la unidad interior que es usado para conectar la unidad interior con la exterior.</p> <p>198V CA a 264V CA?</p> <p>NO</p> <p>Verifique la tensión entre L (Ls) y N en el bloque de terminales (TB1) de la placa de alimentación exterior.</p> <p>198V CA a 264V CA?</p> <p>NO</p> <p>SI</p> <p>Verifique que la tensión entre S1 y S2 en el bloque de terminales (TB1) de la unidad exterior que es usado para conectar la unidad interior con la exterior.</p> <p>198V CA a 264V CA?</p> <p>NO</p> <p>SI</p> <p>Verifique la tensión en la placa controladora interior (CN2D).</p> <p>12V CC a 16V CC?</p> <p>SI</p> <p>NO</p> <p>Verifique la tensión de la unidad después de remover la placa de alimentación interior (CN2S).</p> <p>12V CC a 16V CC?</p> <p>SI</p> <p>NO</p>	<ul style="list-style-type: none"> • Problemas referidos a la alimentación. • Cableado defectuoso de la placa controladora exterior. • Los fusibles en la placa controladora exterior están quemados. • Cableado defectuoso de la placa controladora exterior. • Los fusibles en la placa controladora exterior están quemados. • Placa controladora interior defectuosa. • Cableado defectuoso, roto o conexión pobre del cable de conexión interior/exterior. • Placa de alimentación interior defectuosa. 	<ul style="list-style-type: none"> • Verifique el cableado de alimentación de la unidad exterior. • Verifique la llave térmica. • Verifique el cableado de la unidad exterior. • Verifique si el cableado está mal. • Verifique si los fusibles están quemados. • Los fusibles en el circuito controlador exterior se quemarán cuando se cortocircuita el cable de conexión interior/exterior. • Verifique error de cableado, rotura o contacto pobre que esté causando este problema. • El cable de conexión interior/ exterior es del tipo polarizado de 3 núcleos. Conecte la unidad interior y la unidad exterior cableando cada par S1, S2 y S3 en los bloques de terminales de ambos lados. • Reemplace la placa controladora interior. • Verifique si hay un cable roto o mal cableado. • Reemplace la placa de alimentación interior.

<p>Síntoma: No se exhibe nada en el control remoto.</p>	<p>2</p>	<p>Display LED de la placa controladora interior. LED1:  LED2:  LED3:  or </p>
----------------------------------------------------------------	-----------------	-----------------------------------------------------------------------------------------------------------------------------------------------------------------------------------------------------------------------------------------------------------------------------------------------------------------------------------------------------------------------------------------------------------------------------------------------------------------------------------

Flujo de diagnóstico	Causa	Método de inspección y búsqueda de errores
<p>Verifique que la tensión entre S1 y S2 en el bloque de terminales (TB4) de la unidad interior que es usado para conectar la unidad interior con la exterior.</p> <p>198V CA a 264V CA?</p> <p>SI</p> <p>Verifique el estado del LED3 de la placa controladora interior.</p> <p>Parpadeando</p> <p>Verifique flojedad o desconexión del cable de conexión interior/exterior.</p> <p>Are there looseness or disconnection of the indoor/outdoor connecting wire?</p> <p>NO</p> <p>Verifique la dirección de refrigerante de la unidad exterior (SW1-3 a 1-6).</p> <p>La dirección de refrigerante es "0"?</p> <p>SI</p> <p>Verifique el display LED de la unidad exterior después de encender nuevamente la alimentación.</p> <p>Se exhibe algo?</p> <p>Nos e exhibe.</p> <p>Se exhibe.</p> <p>Se exhibe "EA" o "Eb"?</p> <p>SI</p> <p>Se exhibe "Eb"?</p> <p>NO</p> <p>Se puede rearrancar la unidad?</p> <p>Pueden operarse todas las unidades interiores?</p> <p>SI</p> <p>Verifique la tensión entre S2 y S3 del bloque de terminales de la unidad exterior.</p> <p>17V CC a 28V CC?</p> <p>NO</p> <p>SI</p>	<ul style="list-style-type: none"> • Rotura o contacto pobre del cable de conexión interior/exterior. • Normal. Sólo la unidad que tiene la dirección de refrigerante "0" provee alimentación al control remoto. • Placa controladora exterior defectuosa. • Placa controladora exterior defectuosa. • Placa controladora interior defectuosa. • Influencia de ruido electromagnético. • Placa de alimentación exterior defectuosa. • Placa controladora interior defectuosa. 	<ul style="list-style-type: none"> • Solucione la rotura o contacto pobre del cable de conexión interior/exterior. • Configure la dirección de refrigerante en "0". En caso de sistema de grupos múltiples, verifique nuevamente la dirección de refrigerante. • Reemplace la placa controladora exterior. • Reemplace la placa controladora exterior. • Reemplace la placa controladora interior de la unidad interior que no opera. No es una anomalía. Puede haber interferencia de ruido electromagnético. Verifique el cable de transmisión y elimine las causas de la interferencia. • Reemplace la placa de alimentación exterior. • Reemplace la placa de alimentación interior.



Síntoma: No se exhibe nada en el control remoto.**3**

Display LED de la placa controladora interior.
 LED1 : 
 LED2 :  or 
 LED3 : 

Flujo de diagnóstico	Causa	Método de inspección y búsqueda de errores
<p>Verifique la tensión del bloque de terminales (TB6) del control remoto.</p> <p>10V CC a 16V CC?</p> <p>SI</p> <p>NO</p> <p>Verifique el estado del LED2.</p> <p>Encendida</p> <p>Parpadeando</p> <p>Verifique el estado del LED2 después de desconectar el cable del control remoto del bloque de terminales (TB5) de la unidad interior.</p> <p>Verifique el estado del LED2.</p> <p>Encendida</p> <p>Parpadeando</p>	<ul style="list-style-type: none"> • Control remoto defectuoso. • Rotura o contacto pobre del cable del control remoto. • El cable del control remoto está en corto. • Placa controladora interior defectuosa. 	<ul style="list-style-type: none"> • Reemplace el control remoto. • Verifique si hay alguna rotura o contacto pobre del cable del control remoto. Verifique la tensión del bloque de terminales (TB5) que conecta al cable del control remoto. Si no está entre 10V CC y 16V CC, la placa controladora interior está defectuosa. • Verifique si el cable del control remoto está en corto. • Reemplace la placa controladora interior.

• Antes de reparar

Llamadas frecuentes de los clientes.



	Llamadas de los clientes	Cómo responder	Nota
La unidad no opera en absoluto	1 El display de operación del control remoto no se enciende.	1 Verifique si el acondicionador de aire recibe alimentación. No aparece nada en la pantalla a menos que reciba alimentación.	
	2 La unidad no puede rearmarse por un rato después de que es detenida.	2 Espere aproximadamente 3 minutos para rearmar la unidad. El acondicionador de aire está en un estado de protección por una directiva del microcomputador. Una vez que el compresor se detiene, la unidad no puede rearmarse por 3 minutos. Este control también se aplica cuando la unidad es encendida y apagada por el control remoto o el termostato.	
	3 Aparece un código de error y parpadea en el display del control remoto.	3 Se exhibirá el código de error si alguno de los dispositivos de protección del acondicionador actuó. Cuál es el código de error?	Refiérase a la "TABLA DE ACCIÓN DE AUTODIAGNÓSTICO". Verifique si se requiere servicio para el error.
Control remoto	1 Aparece "PLEASE WAIT" en el display.	1 Espere aproximadamente 2 minutos. Se conducirá un test automático de arranque durante 2 minutos cuando se provee alimentación al acondicionador de aire. Se exhibirá "PLEASE WAIT" durante ese tiempo.	
	2 Aparece "FILTER" en el display.	2 Esto indica que es momento de limpiar los filtros de aire. Limpie los filtros de aire. Presione el botón FILTER en el control remoto dos veces para borrar el cartel "FILTER" del display. Vea el manual de operación que viene con el equipo para indicaciones de cómo limpiar los filtros.	El tiempo de exhibición de "FILTER" depende del modelo. Filtro de larga vida: 2500 horas. Filtro regular: 100 horas.
	3 Aparece "STANDBY" en el display.	3 Esto se exhibe cuando la unidad inicia la operación de CALEFACCIÓN, cuando el termostato pone al compresor en modo de operación, o cuando la unidad exterior finaliza la operación de desescarchado y regresa a la operación de calefacción. El display desaparecerá automáticamente aproximadamente 10 minutos después. Mientras se exhibe "STANDBY" en el control remoto, el la cantidad de flujo de aire será restringida dado que el intercambiador de calor de la unidad interior no está totalmente calentado. Además de eso, las aletas automáticas quedarán fijadas en posición de soplado horizontal para evitar que el aire frío se sople directamente al cuerpo humano. Las aletas de hacia arriba/abajo regresará a la configuración especificada por el control remoto cuando se libere del "STANDBY".	
	4 Aparece "DEFROSTING" en el display. (No sale aire de la unidad).	4 La unidad exterior se congela cuando la temperatura exterior es baja y la humedad es alta. "DEFROSTING" indica que la operación de desescarchado está siendo efectuada para derretir la escarcha. La operación de desescarchado finaliza en aproximadamente 10 minutos (como máximo 15 minutos). Durante la operación de desescarchado, el intercambiador de calor de la unidad interior se enfría, por lo que se detiene al soplador. El movimiento ascendente/descendente de las aletas se fija automáticamente en soplado horizontal para evitar que aire frío sople en forma directa al cuerpo de la gente. El display regresará a "STANDBY" cuando finalice la operación de desescarchado.	

Llamadas de los clientes	Cómo responder	Nota	
No se puede calefactar suficientemente la habitación.	<p>1 Verifique la temperatura configurada en el control remoto. La unidad exterior no puede ser operada se la temperatura configurada no es apropiada. La unidad exterior opera en lo siguientes modos. FRÍO: Cuando la temperatura configurada es menor que la temperatura ambiente. CALOR: Cuando la temperatura configurada es superior a la temperatura ambiente.</p> <p>2 Verifique si los filtros están obstruidos o sucios. Si los filtros está obstruidos, la cantidad de flujo de aire se reducirá y la capacidad del equipo se reducirá. Vea el manual de instrucciones que viene con el producto para saber cómo se limpian los filtros.</p> <p>3 Verifique si hay suficiente espacio alrededor del acondicionador de aire. Si hay obstáculos en la entrada o salida de aire de las unidades interior/ exterior, bloquearán la dirección del flujo de aire reduciendo la capacidad de la unidad.</p>		
El equipo de aire acondicionado hace ruido.	1 A veces se escucha un sonido de escapar de gas.	1 Esto no es una falla. Este es el sonido el cual es escuchado cuando el flujo de refrigerante en el acondicionador de aire es conmutado.	
	2 A veces se escucha un crujido.	2 Esto no es una falla. Este es el sonido que se escucha cuando las partes internas de la unidad se expanden o contraen cuando la temperatura cambia.	
	3 A veces se escucha un zumbido.	3 Esto no es una falla. Este es el sonido que se escucha cuando la unidad exterior comienza a operar.	
	4 A veces se escucha un golpeteo en la unidad exterior.	4 Esto no es una falla. Este es el sonido que se escucha cuando el soplador de la unidad exterior está controlando la cantidad de flujo de aire de modo de mantener la condición óptima de operación.	
	5 Se escucha un sonido similar a como si fluyera agua desde la unidad.	5 Esto no es una falla. Este es el sonido que se escucha cuando el refrigerante fluye dentro de la unidad interior.	
Algo está mal en el soplador	1 La velocidad del ventilador no corresponde con la del control remoto durante la operación de secado. (No sale aire a veces durante la operación de secado).	1 Esto no es una falla. Durante la operación de secado, el encendido/apagado del soplador es controlado por la microcomputadora para evitar el sobreenfriamiento y asegurar una deshumidificación eficiente. La velocidad del ventilador no puede ser configurada por el control remoto durante la operación de secado.	
	2 La velocidad del ventilador no corresponde con la del control remoto durante la operación de calefacción.	<p>2 Esto no es una falla.</p> <p>1) Cuando arranca la operación de calefacción, para prevenir que la unidad sople aire frío, la velocidad del ventilador se aumenta gradualmente desde cero hasta la velocidad configurada, en proporción al aumento de temperatura de descarga de aire.</p> <p>2) Cuando la temperatura ambiente alcanza la temperatura configurada, la unidad inicia la operación de bajo aire.</p> <p>3) Durante la operación de calefacción, se efectúa la operación de desescarchado para descongelar a la unidad exterior. Durante la operación de desescarchado, se detiene el soplador para evitar que el aire frío salga desde la unidad interior.</p>	La aleta hacia arriba/abajo se configurará automáticamente a la posición horizontal en los casos enumerados arriba a la izquierda (1 a 3). Después de un rato, dicha aleta comenzará a moverse automáticamente de acuerdo a la configuración del control remoto.

	Llamadas de los clientes	Cómo responder	Nota
Algo está mal con el soplador	3 El aire sopla por un rato después que la operación de calefacción se detuvo.	3 Esto no es una falla. El soplador está operando sólo para enfriar al acondicionador de aire calentado. Esto se efectuará en un minuto. Este control se conduce sólo cuando se detiene la operación de calefacción con el calefactor eléctrico encendido.	No obstante, este control también es aplicado a los modelos que no tienen calefactor eléctrico.
Algo está mal con la dirección del flujo de aire	1 Se cambia la dirección del flujo de aire durante la operación de refrigeración.	1 Si la aleta arriba/abajo está configurada hacia abajo en la operación de refrigeración, se configurará en forma automática a la posición de soplado horizontal por la microcomputadora a fin de prevenir que gotee agua. Se exhibirá "1 Hr. en el control remoto si la aleta hacia arriba/abajo se configura hacia abajo con la velocidad del ventilador configurada para ser menor que "LOW".	
	2 Se cambia la dirección del flujo de aire durante la operación de calefacción. (La dirección del aire no se puede configurar con el control remoto).	3 En la operación de calefacción, la aleta arriba/abajo se controla automáticamente de acuerdo a la temperatura del intercambiador de calor de la unidad interior. En los siguientes casos, la aleta arriba/abajo se configurará a soplado horizontal y la configuración no se podrá cambiar mediante el control remoto. 1) Al principio de la operación de calefacción. 2) Mientras la unidad exterior está siendo detenida por el termostato o cuando la unidad exterior inicia la operación. 3) Durante la operación de desescarchado La dirección del flujo de aire volverá a la configuración del control remoto cuando se resuelvan las situaciones de arriba.	Se exhibirá "STANDBY" en el control remoto en el caso de 1 y 2. Se exhibirá en el display "DEFROSTING" en el caso de 3.
	3 La dirección del flujo de aire no cambia. (Aleta hacia arriba/abajo, louver izquierda/derecha).	3 1) Verifique si la aleta se configura a una posición fija. (Verifique si está flojo el conector del motor de la aleta) 2) Verifique si el acondicionador de aire tiene una función para conmutar la dirección del aire. 3) Si el acondicionador de aire no tiene esa función, se exhibirá "NOT AVAILABLE" en el control remoto cuando se presione el botón "AIR DIRECTION" o "LOUVER".	
El acondicionador de aire comienza la operación aunque ninguno de los botones del control remoto sean presionados.		1 Verifique si configuró el temporizador de encendido/apagado. El acondicionador de aire comienza la operación a la hora designada se previamente se configuró el temporizador de encendido.	
		2 Verifique si alguna operación es ordenada por un sistema de control lejano o por el control remoto central. Mientras se exhiba en el display del control remoto "CENTRALLY CONTROLLED", el acondicionador de aire está bajo el control de directiva externa.	Puede haber un caso en que no se exhiba el mensaje "CENTRALLY CONTROLLED".
		3 Verifique si se recupera la alimentación de una falla de alimentación (corte general). La unidad comenzará la operación automáticamente cuando se recupere la alimentación después de que ocurra la falla (corte). Esta función es llamada "recuperación automática de falla de alimentación".	
El acondicionador de aire se detiene aunque no se presione ningún botón del control remoto.		1 Verifique si configuró el temporizador de encendido/apagado. El acondicionador de aire detiene la operación a la hora designada se previamente se configuró el temporizador de apagado.	Puede haber un caso en que no se exhiba el mensaje "CENTRALLY CONTROLLED".
		2 Verifique si alguna operación es ordenada por un sistema de control lejano o por el control remoto central. Mientras se exhiba en el display del control remoto "CENTRALLY CONTROLLED", el equipo de aire está bajo el control de directiva externa.	

Llamadas de los clientes	Cómo responder	Nota
La unidad interior sopla una neblina blanca.	Esto no es una falla. Esto puede ocurrir cuando la operación se inicia en una habitación con mucha humedad.	
Se expele agua o humedad desde la unidad exterior.	Refrigeración: cuando las juntas de las cañerías son enfriadas, se humedecen y el agua corre hacia abajo. Calefacción: el agua chorrea desde el intercambiador de calor. * Utilice el "Zócalo de drenaje" opcional y el "Panel de drenaje" si el agua necesita ser recolectada y drenada hacia afuera.	
El display del control remoto inalámbrico disminuye su contraste o se apaga. La unidad interior no recibe señal desde el control remoto a larga distancia.	Las baterías están agotadas. Reemplázelas y presione el botón reset del control remoto.	

PUHZ-RP35/50/60/71VHA4
PUHZ-RP100/125/140VKA
PUHZ-RP100/125/140/200/250YKA
PUHZ-RP200YKAR1

Parts name	Check points														
Thermistor (TH3) <Outdoor pipe> Thermistor (TH4) <Discharge> Thermistor (TH6) <Outdoor pipe> Thermistor (TH7) <Outdoor> Thermistor (TH8) <Heatsink> Thermistor (TH32) <Shell> Thermistor (TH33) <Outdoor pipe>	Disconnect the connector then measure the resistance with a tester. (At the ambient temperature 10°C~30°C) <table border="1" style="margin-top: 10px;"> <thead> <tr> <th></th> <th>Normal</th> <th>Abnormal</th> </tr> </thead> <tbody> <tr> <td>TH4, TH32</td> <td>160kΩ~410kΩ</td> <td rowspan="5">Open or short</td> </tr> <tr> <td>TH3</td> <td rowspan="4">4.3kΩ~9.6kΩ</td> </tr> <tr> <td>TH6</td> </tr> <tr> <td>TH7</td> </tr> <tr> <td>TH33</td> </tr> <tr> <td>TH8</td> <td>39kΩ~105kΩ</td> </tr> </tbody> </table>		Normal	Abnormal	TH4, TH32	160kΩ~410kΩ	Open or short	TH3	4.3kΩ~9.6kΩ	TH6	TH7	TH33	TH8	39kΩ~105kΩ	
	Normal	Abnormal													
TH4, TH32	160kΩ~410kΩ	Open or short													
TH3	4.3kΩ~9.6kΩ														
TH6															
TH7															
TH33															
TH8	39kΩ~105kΩ														
Fan motor(MF1,MF2)	Refer to next page.														
Solenoid valve coil <Four-way valve> (21S4)	Measure the resistance between the terminals with a tester. (At the ambient temperature 20°C) <table border="1" style="margin-top: 10px;"> <thead> <tr> <th colspan="2">Normal</th> <th>Abnormal</th> </tr> </thead> <tbody> <tr> <td>RP35-71</td> <td>RP100-250</td> <td rowspan="2">Open or short</td> </tr> <tr> <td>2350±170Ω</td> <td>1435±150Ω</td> </tr> </tbody> </table>	Normal		Abnormal	RP35-71	RP100-250	Open or short	2350±170Ω	1435±150Ω						
Normal		Abnormal													
RP35-71	RP100-250	Open or short													
2350±170Ω	1435±150Ω														
Motor for compressor (MC) 	Measure the resistance between the terminals with a tester. (Winding temperature 20°C) <table border="1" style="margin-top: 10px;"> <thead> <tr> <th>Normal</th> <th>Abnormal</th> </tr> </thead> <tbody> <tr> <td>Refer to 6-2.</td> <td>Open or short</td> </tr> </tbody> </table>	Normal	Abnormal	Refer to 6-2.	Open or short										
Normal	Abnormal														
Refer to 6-2.	Open or short														
Solenoid valve coil (LEV-A/ LEV-B) For RP35-RP71 	Disconnect the connector then measure the resistance with a tester. (Winding temperature 20°C) <table border="1" style="margin-top: 10px;"> <thead> <tr> <th colspan="4">Normal</th> <th>Abnormal</th> </tr> </thead> <tbody> <tr> <td>Red - White</td> <td>Red - Orange</td> <td>Brown - Yellow</td> <td>Brown - Blue</td> <td rowspan="2">Open or short</td> </tr> <tr> <td colspan="4">46±4Ω</td> </tr> </tbody> </table>	Normal				Abnormal	Red - White	Red - Orange	Brown - Yellow	Brown - Blue	Open or short	46±4Ω			
Normal				Abnormal											
Red - White	Red - Orange	Brown - Yellow	Brown - Blue	Open or short											
46±4Ω															
Solenoid valve coil (LEV-A/ LEV-B) For RP100-RP250 	Disconnect the connector then measure the resistance with a tester. (Winding temperature 20°C) <table border="1" style="margin-top: 10px;"> <thead> <tr> <th colspan="4">Normal</th> <th>Abnormal</th> </tr> </thead> <tbody> <tr> <td>Gray - Black</td> <td>Gray - Red</td> <td>Gray - Yellow</td> <td>Gray - Orange</td> <td rowspan="2">Open or short</td> </tr> <tr> <td colspan="4">46±3Ω</td> </tr> </tbody> </table>	Normal				Abnormal	Gray - Black	Gray - Red	Gray - Yellow	Gray - Orange	Open or short	46±3Ω			
Normal				Abnormal											
Gray - Black	Gray - Red	Gray - Yellow	Gray - Orange	Open or short											
46±3Ω															

Check method of DC fan motor (fan motor / outdoor controller circuit board)

① Notes

- High voltage is applied to the connector (CNF1, 2) for the fan motor. Pay attention to the service.
- Do not pull out the connector (CNF1, 2) for the motor with the power supply on.
(It causes trouble of the outdoor controller circuit board and fan motor.)

② Self check

Symptom : The outdoor fan cannot turn around.

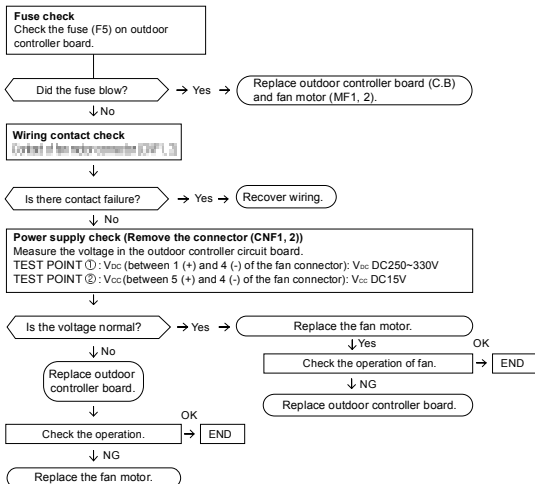

11-7. HOW TO CHECK THE COMPONENTS

<Thermistor feature chart>

Low temperature thermistors

- Thermistor <Outdoor pipe> (TH3)
- Thermistor <Outdoor 2-phase pipe> (TH6)
- Thermistor <Outdoor> (TH7)
- Thermistor <Outdoor pipe> (TH33)

Thermistor R0 = 15kΩ ± 3%

B constant = 3480 ± 2%

$$R_t = 15 \exp\left\{3480\left(\frac{1}{273+t} - \frac{1}{273}\right)\right\}$$

0°C	15kΩ	30°C	4.3kΩ
10°C	9.6kΩ	40°C	3.0kΩ
20°C	6.3kΩ		
25°C	5.2kΩ		

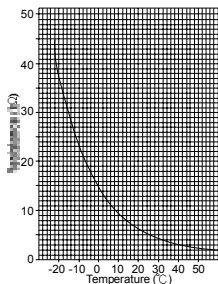

Medium temperature thermistor

- Thermistor <Heatsink> (TH8)
- RRP35-RP71V only

Thermistor R50 = 17kΩ ± 2%

B constant = 4150 ± 3%

$$R_t = 17 \exp\left\{4150\left(\frac{1}{273+t} - \frac{1}{323}\right)\right\}$$

0°C	180kΩ
25°C	50kΩ
50°C	17kΩ
70°C	8kΩ
90°C	4kΩ

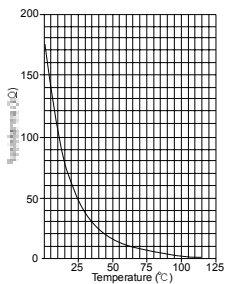

High temperature thermistor

- Thermistor <Discharge> (TH4)
- Thermistor <Shell> (TH32)

Thermistor R120 = 7.465kΩ ± 2%

B constant = 4057 ± 2%

$$R_t = 7.465 \exp\left\{4057\left(\frac{1}{273+t} - \frac{1}{393}\right)\right\}$$

20°C	250kΩ	70°C	34kΩ
30°C	160kΩ	80°C	24kΩ
40°C	104kΩ	90°C	17.5kΩ
50°C	70kΩ	100°C	13.0kΩ
60°C	48kΩ	110°C	9.8kΩ

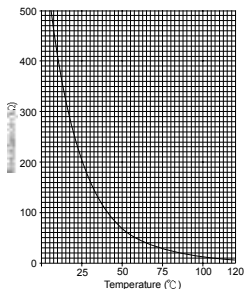

Linear expansion valve (RP35-RP71)

(1) Operation summary of the linear expansion valve

- Linear expansion valve opens/closes through stepping motor after receiving the pulse signal from the outdoor controller board.
- Valve position can be changed in proportion to the number of pulse signal.

<Connection between the outdoor controller board and the linear expansion valve>

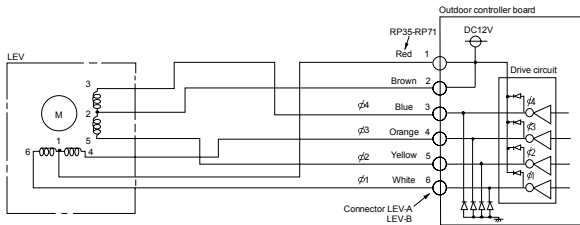

<Output pulse signal and the valve operation>

Output (Phase)	Output							
	1	2	3	4	5	6	7	8
φ1	ON	ON	OFF	OFF	OFF	OFF	OFF	ON
φ2	OFF	ON	ON	ON	OFF	OFF	OFF	OFF
φ3	OFF	OFF	OFF	ON	ON	ON	OFF	OFF
φ4	OFF	OFF	OFF	OFF	OFF	ON	ON	ON

Opening a valve : 8 → 7 → 6 → 5 → 4 → 3 → 2 → 1 → 8

Closing a valve : 1 → 2 → 3 → 4 → 5 → 6 → 7 → 8 → 1

The output pulse shifts in above order.

- When linear expansion valve operation stops, all output phase become OFF.

(2) Linear expansion valve operation

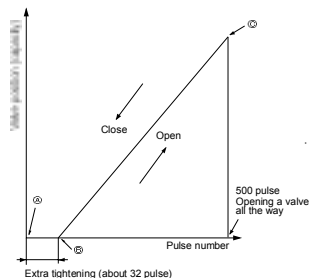

- When the switch is turned on, 700 pulse closing valve signal will be sent till it goes to ④ point in order to define the valve position. (The pulse signal is being sent for about 20 seconds.)

When the valve moves smoothly, there is no sound or vibration occurring from the linear expansion valve ; however, when the pulse number moves from ③ to ④ or when the valve is locked, more sound can be heard.

No sound is heard when the pulse number moves from ④ to ③ in case coil is burnt out or motor is locked by open-phase.

- Sound can be detected by placing the ear against the screw driver handle while putting the screw driver to the linear expansion valve.

Linear expansion valve (RP100-RP250)

(1) Operation summary of the linear expansion valve

- Linear expansion valve opens/closes through stepping motor after receiving the pulse signal from the outdoor controller board.
- Valve position can be changed in proportion to the number of pulse signal.

<Connection between the outdoor controller board and the linear expansion valve>

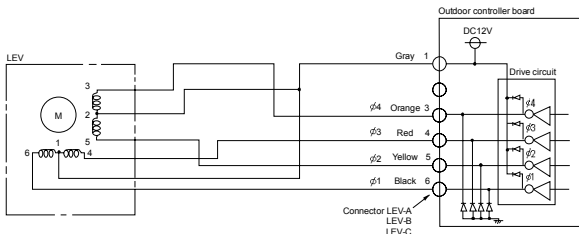

<Output pulse signal and the valve operation>

Output (Phase)	Output							
	1	2	3	4	5	6	7	8
$\phi 1$	ON	ON	OFF	OFF	OFF	OFF	OFF	ON
$\phi 2$	OFF	ON	ON	ON	OFF	OFF	OFF	OFF
$\phi 3$	OFF	OFF	OFF	ON	ON	ON	OFF	OFF
$\phi 4$	OFF	OFF	OFF	OFF	OFF	ON	ON	ON

Opening a valve : 8 → 7 → 6 → 5 → 4 → 3 → 2 → 1 → 8

Closing a valve : 1 → 2 → 3 → 4 → 5 → 6 → 7 → 8 → 1

The output pulse shifts in above order.

- When linear expansion valve operation stops, all output phase become OFF.

(2) Linear expansion valve operation

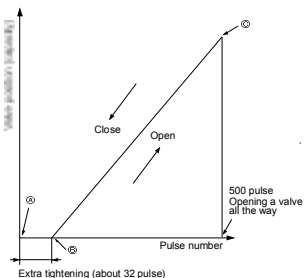

- When the switch is turned on, 700 pulse closing valve signal will be sent till it goes to (b) point in order to define the valve position. (The pulse signal is being sent for about 20 seconds.)

When the valve moves smoothly, there is no sound or vibration occurring from the linear expansion valve : however, when the pulse number moves from (a) to (b) or when the valve is locked, more sound can be heard.

No sound is heard when the pulse number moves from (a) to (b) in case coil is burnt out or motor is locked by open-phase.

- Sound can be detected by placing the ear against the screw driver handle while putting the screw driver to the linear expansion valve.

(3) How to attach and detach the coil of linear expansion valve (RP35-RP71)

<Composition>

Linear expansion valve is separable into the main body and the coil as shown in the diagram below.

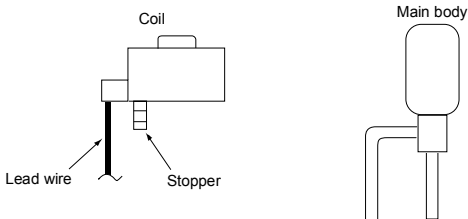
**<How to detach the coil>**

Hold the lower part of the main body (shown as A) firmly so that the main body does not move and detach the coil by pulling it upward.

Be sure to detach the coil holding main body firmly. Otherwise pipes can bend due to pressure.

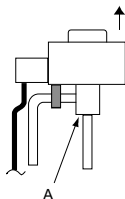
**<How to attach the coil>**

Hold the lower part of the main body (shown as A) firmly so that the main body does not move and attach the coil by inserting it downward into the main body. Then securely attach the coil stopper to pipe B. (At this time, be careful that stress is not added to lead wire and main body is not wound by lead wire.) If the stopper is not firmly attached to pipe B, coil may be detached from the main body and that can cause defective operation of linear expansion valve.

To prevent piping stress, be sure to attach the coil holding the main body of linear expansion valve firmly. Otherwise pipe may break.

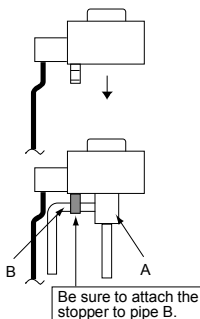

(4) How to attach and detach the coil of linear expansion valve (RP100-RP250)

<Composition>

Linear expansion valve is separable into the main body and the coil as shown in the diagram below.

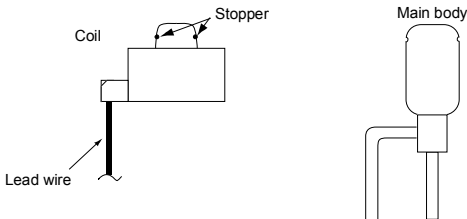

<How to detach the coil>

Hold the lower part of the main body (shown as A) firmly so that the main body does not move and detach the coil by pulling it upward.

Be sure to detach the coil holding main body firmly. Otherwise pipes can bend due to pressure.

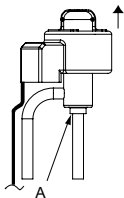

<How to attach the coil>

Hold the lower part of the main body (shown as A) firmly so that the main body does not move and attach the coil by inserting it downward into the main body. Then securely attach the coil stopper to main body. (At this time, be careful that stress is not added to lead wire and main body is not wound by lead wire.) If the stopper is not firmly attached to main body, coil may be detached from the main body and that can cause defective operation of linear expansion valve.

To prevent piping stress, be sure to attach the coil holding the main body of linear expansion valve firmly. Otherwise pipe may break.

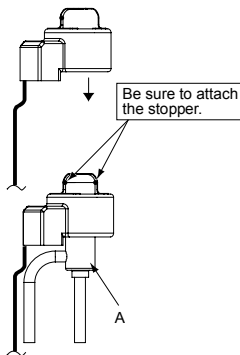

11-8. EMERGENCY OPERATION

- (1) When the error codes shown below are displayed on outdoor unit or microcomputer for wired remote controller or indoor unit has a failure, but no other problems are found, emergency operation will be available by setting the emergency operation switch (SWE) on indoor controller board to ON and short-circuiting the connector (CN31) on outdoor controller board.

●When following abnormalities occur, emergency operation will be available.

Error code	Inspected content
U4	Open/short of outdoor unit thermistor (TH3/TH6/TH7/TH8)
E8	Indoor/outdoor unit communication error • Signal receiving error (Outdoor unit)
E9	Indoor/outdoor unit communication error • Transmitting error (Indoor unit)
E0 ~ E7	Communication error other than outdoor unit
Ed	Communication error between outdoor controller board and M-NET board (Serial communication error)

(2) Check the following items and cautions for emergency operation

- ① Make sure that there is no abnormality in outdoor unit other than the above abnormalities. (Emergency operation will not be available when error code other than the above are indicated.)
- ② For emergency operation, it is necessary to set the emergency operation switch (SWE) on indoor controller board. Refer to the electrical wiring diagram of indoor unit for how to set the indoor unit.
- ③ During emergency operation, the air-conditioner will continuously be operated by supplying power and stopping it: It cannot be turned on or off by remote control, and temperature control is not possible.
- ④ Do not perform emergency heating operation for an extended period of time: If the outdoor unit starts defrosting during this period, cold air will blow out from the indoor unit.
- ⑤ Do not perform emergency cooling operation for more than 10 hours: Neglecting this could result in freezing the heat exchanger in indoor unit.

(3) Emergency operation procedure

- ① Turn the main power supply off.
- ② Turn on the emergency operation switch (SWE) on indoor controller board.
- ③ Set the shorting pins of emergency operation connector (CN31) on outdoor controller board to ON.
- ④ Use SW4-2 on outdoor controller board to set the operation mode (cooling or heating). (SW4-1 is not used.)

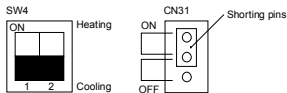

- ⑤ Turning the main power supply on will start the emergency operation.

(4) Releasing emergency operation

- ① Turn the main power supply off.
- ② Set the emergency operation switch (SWE) on indoor controller board to OFF.
- ③ Set the shorting pins of emergency operation connector (CN31) on outdoor controller board to OFF.
- ④ Set SW4-2 on outdoor controller board as shown in the right.

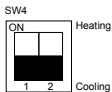

* If shorting pins are not set on emergency operation connector (CN31), the setting remains OFF.

(5) Operation data during emergency operation

During emergency operation, no communication is performed with the indoor unit, so the data items needed for operation are set to the following values:

Operation data	Operation mode		Remarks
	COOL	HEAT	
Intake temperature (TH1)	27°C	20.5°C	—
Indoor pipe temperature (TH2)	5°C	45°C	—
Indoor 2-phase pipe temperature (TH5)	5°C	50°C	—
Set temperature	25°C	22°C	—
Outdoor pipe temperature (TH3)	45°C	5°C	(※1)
Outdoor discharge pipe temperature (TH4)	80°C	80°C	(※1)
Outdoor 2-phase pipe temperature (TH6)	50°C	5°C	(※1)
Outdoor ambient temperature (TH7)	35°C	7°C	(※1)
Temperature difference code (room temperature - set temperature) (ΔT)	5	5	—
Discharge superheat (SHd)	30deg	30deg	(※2)
Sub-cool (SC)	5deg	5deg	(※2)

※1: If the thermistor temperature data is normal (not open/short), that data is loaded into the control as valid data.

When the unit enters emergency operation and TH values are mismatched, set the thermistors to open/short.

And the unit runs emergency operation with the values listed above.

※2: If one thermistor is set to open/short, the values for SHd/SC will be different from the list above.

[Example] When liquid temperature thermistor (TH3) has an open or short circuit.

Thermistor	COOL	HEAT
TH3	45°C	5°C
TH6	Ta	Tb
	Required normal figure is effective value	
TH4	Tc	Td
	Required normal figure is effective value	
TH5	5°C	50°C
TH2	5°C	45°C

Discharge superheat (SHd)

Cooling = TH4 - TH6 = Tc - Ta

Heating = TH4 - TH5 = Td - 50

Degree of subcooling (SC)

Cooling = TH6 - TH3 = Ta - 45

Heating = TH5 - TH2 = 50 - 45 = 5 deg.

11-9. TEST POINT DIAGRAM

Outdoor controller circuit board

PUHZ-RP35/50/60/71VHA4

PUHZ-RP100/125/140VKA

PUHZ-RP100/125/140/200/250YKA

PUHZ-RP200YKAR1

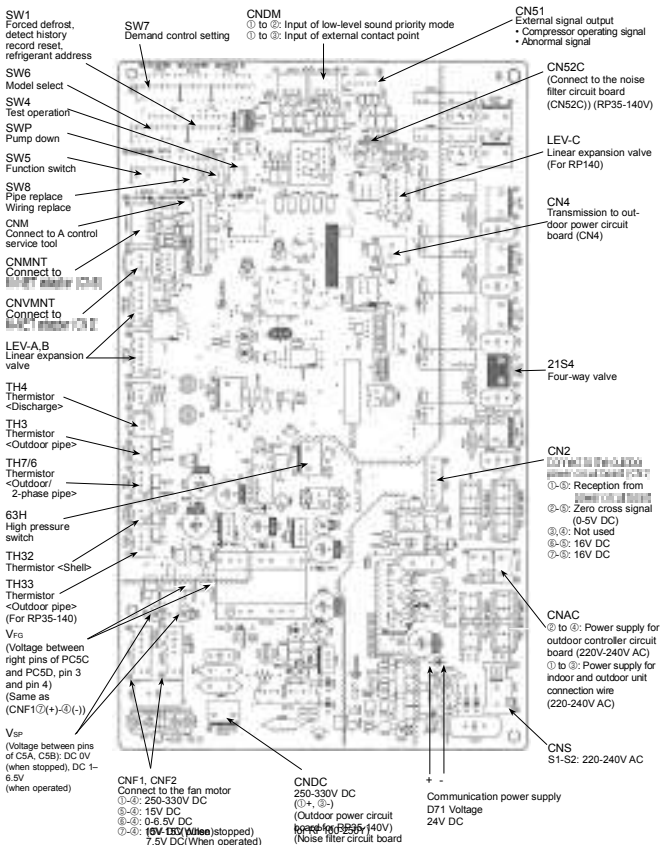
<CAUTION> TEST POINT① is high voltage.

Outdoor noise filter circuit board
PUHZ-RP35VHA4
PUHZ-RP50VHA4

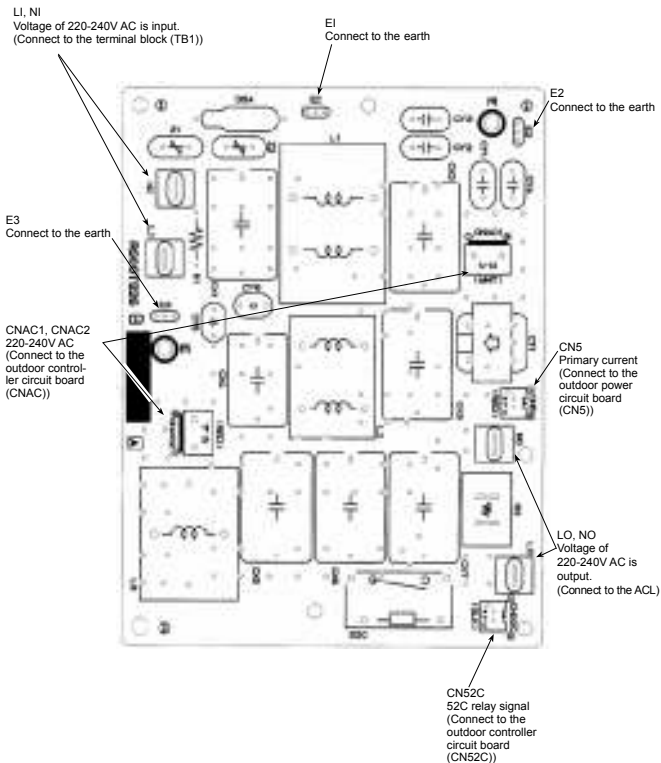

Outdoor noise filter circuit board
PUHZ-RP60VHA4
PUHZ-RP71VHA4

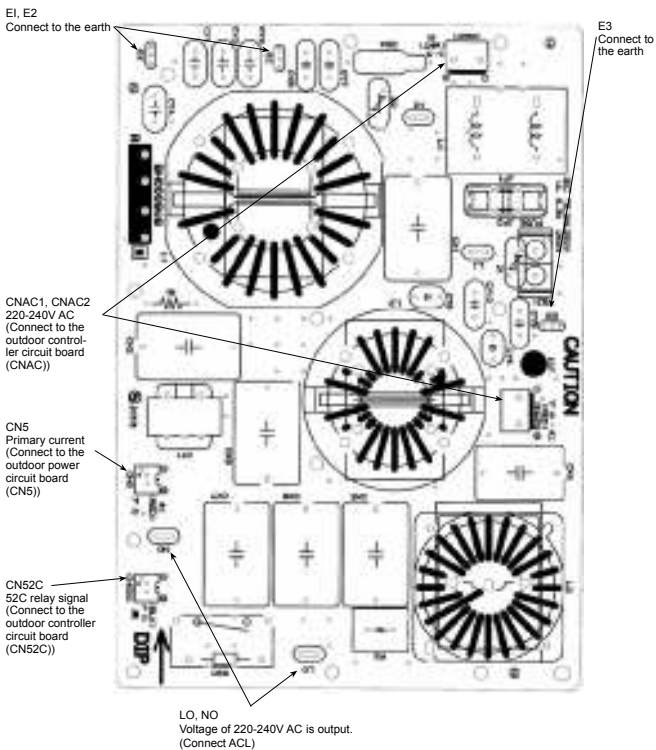

Outdoor noise filter circuit board

**PUHZ-RP100YKA
PUHZ-RP125YKA
PUHZ-RP140YKA
PUHZ-RP200YKA
PUHZ-RP200YKAR1
PUHZ-RP250YKA**

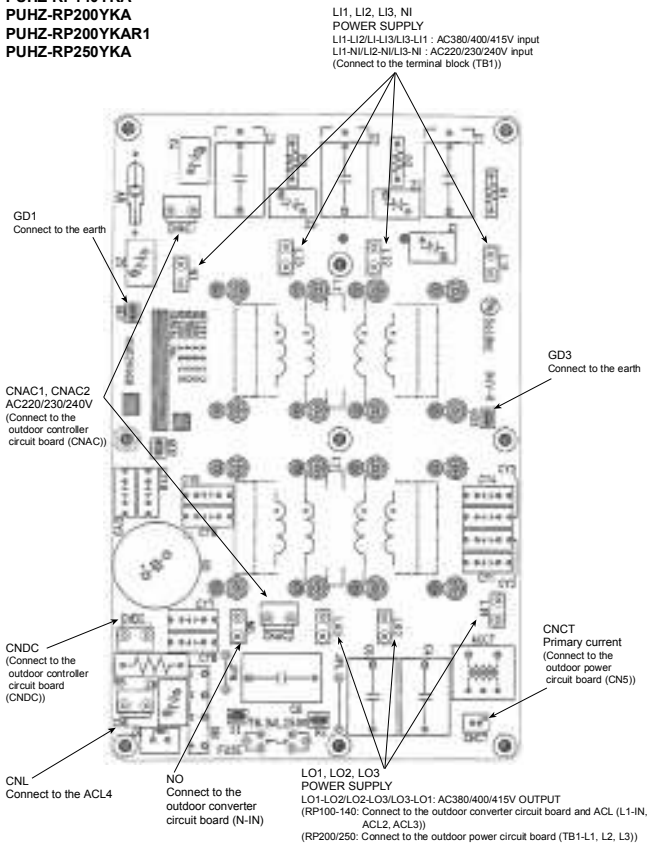

Outdoor power circuit board

PUHZ-RP35VHA4

PUHZ-RP50VHA4

PUHZ-RP60VHA4

PUHZ-RP71VHA4

Brief Check of DIP-IPM and DIP-PFC

※ Usually, they are in a state of being short-circuited if they are broken. Measure the resistance in the following points (connectors, etc.). If they are short-circuited, it means that they are broken.

1. Check of DIP-IPM

[P2]-[U], [P2]-[V], [P2]-[W], [N2]-[U], [N2]-[V], [N2]-[W]

2. Check of DIP-PFC

[P1]-[L], [P1]-[N], [L]-[N1], [N]-[N1]

Note: The marks [L], [N], [N1], [N2], [P1], [P2], [U], [V] and [W] shown in the diagram are not actually printed on the board.

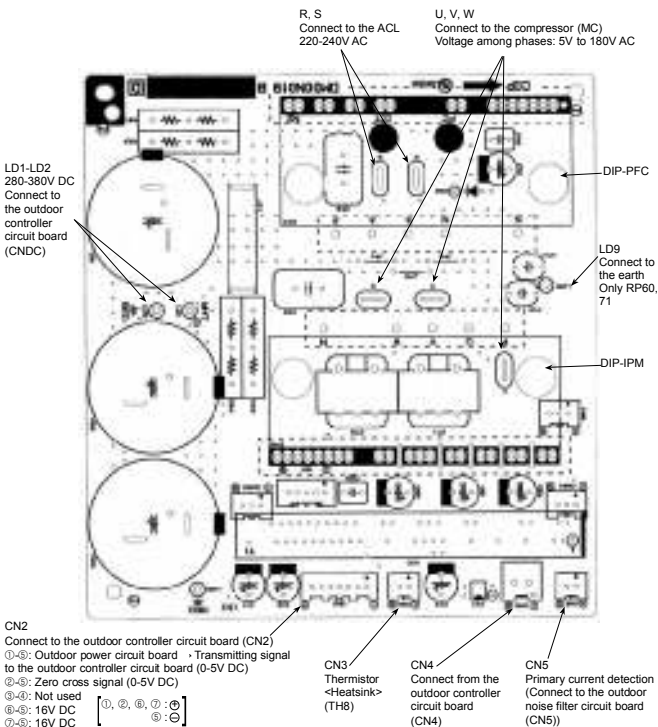

Outdoor power circuit board
PUHZ-RP100VKA
PUHZ-RP125VKA
PUHZ-RP140VKA

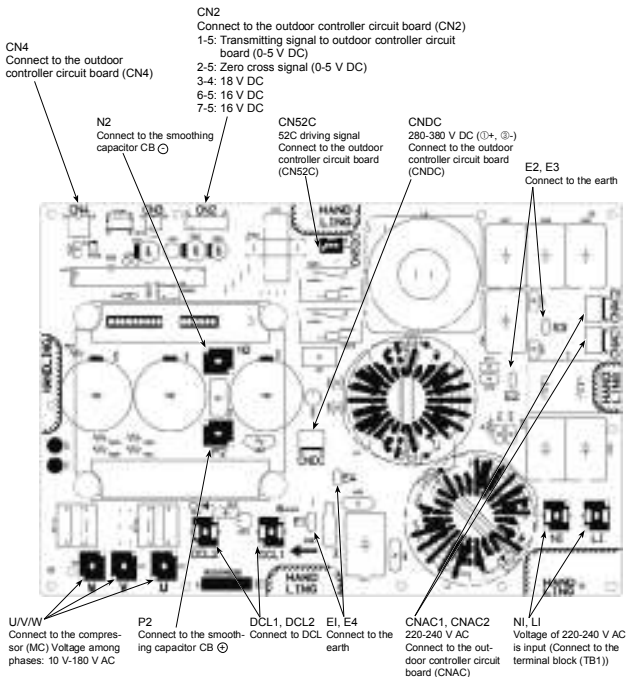

Outdoor power circuit board

PUHZ-RP100YKA

PUHZ-RP125YKA

PUHZ-RP140YKA

PUHZ-RP200YKA

PUHZ-RP200YKAR1

PUHZ-RP250YKA

Brief Check of POWER MODULE

* Usually, they are in a state of being short-circuited if they are broken.
 Measure the resistance in the following points (connectors, etc.).
 If they are short-circuited, it means that they are broken.

1. Check of POWER MODULE

① Check of DIODE circuit

L1-P1, L2-P1, L3-P1, L1-N1, L2-N1, L3-N1

② Check of IGBT circuit

P2-U, P2-V, P2-W, N2-U, N2-V, N2-W

Note: The marks, L1, L2, L3, N1, N2, P1, P2, U, V and W shown in the diagram are not actually printed on the board.

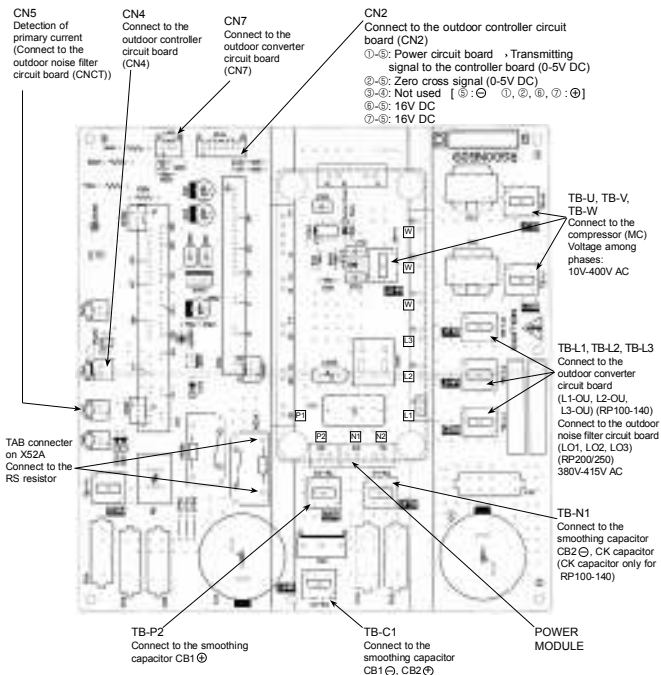

Outdoor converter circuit board
PUHZ-RP100YKA
PUHZ-RP125YKA
PUHZ-RP140YKA



Outdoor M-NET board (optional)

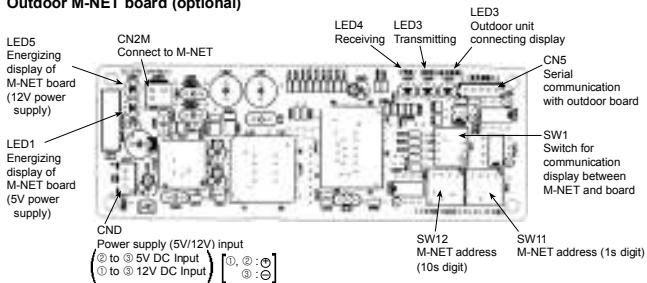

<Display function of inspection for outdoor unit>

The blinking patterns of both LED1 (green) and LED2 (red) indicate the types of abnormality when it occurs. Types of abnormality can be indicated in details by connecting an optional part 'A-Control Service Tool (PAC-SK52ST)' to connector CNM on outdoor controller board.

[Display]

(1) Normal condition

Unit condition	Outdoor controller board		A-Control Service Tool	
	LED1 (Green)	LED2 (Red)	Error code	Indication of the display
When the power is supplied	Lighted	Lighted	— ↔ —	Alternately blinking display
When unit stops	Lighted	Not lighted	00, etc.	Operation mode
When compressor is running	Lighted	Not lighted	08, etc.	
When unit operates	Lighted	Lighted	C5, H7 etc.	

(2) Abnormal condition

Indication		Contents	Error code ※1	Inspection method	Detailed reference page
Outdoor controller board	LED1 (Green) / LED2 (Red)				
1 blinking	2 blinking	Connector (63H) is open.	F5	① Check if connector (63H) on the outdoor controller board is not always connected. ② Check continuity of power supply switch (63H) by tester.	P.42
2 blinking	1 blinking	Miswiring of indoor/outdoor connecting wire (reverse wiring or disconnection)	—	① Check if indoor/outdoor connecting wire is connected correctly. ② Check if 4 or more indoor units are connected to outdoor unit.	P.43 (EA)
		Miswiring of indoor/outdoor unit connecting wire (converse wiring or disconnection)	—	③ Check if noise entered into indoor/outdoor connecting wire or power supply. ④ Re-check error by turning off power, and on again.	P.43 (Eb)
		Startup time over	—	④ Re-check error by turning off power, and on again.	P.43 (EC)
	2 blinking	2 blinking	Indoor control and Comma control error (power wiring error) is detected by outdoor unit.	E6	① Check if indoor/outdoor connecting wire is connected correctly. ② Check if noise entered into indoor/outdoor connecting wire or power supply.
Indoor control and Comma control error (power wiring error) is detected by indoor unit.			E7	③ Check if noise entered into indoor/outdoor connecting wire.	P.48
Indoor control and Comma control error (power wiring error) is detected by outdoor unit.			—	④ Re-check error by turning off power, and on again.	P.48 (E8)
Indoor control and Comma control error (power wiring error) is detected by outdoor unit.			—		P.48 (E9)
3 blinking	3 blinking	Remote controller signal receiving error is detected by remote controller.	E0	① Check if connecting wire of indoor unit or remote controller is connected correctly.	P.47
		Remote controller transmitting error is detected by remote controller.	E3	② Check if noise entered into transmission wire of remote controller.	P.48
		Remote controller signal receiving error is detected by indoor unit.	E4	③ Re-check error by turning off power, and on again.	P.48
		Remote controller transmitting error is detected by indoor unit.	E5		P.48
4 blinking	4 blinking	Error code is not defined.	EF	① Check if remote controller is MA remote controller (MA-2100A). ② Check if noise entered into transmission wire of remote controller. ③ Check if noise entered into indoor/outdoor connecting wire. ④ Re-check error by turning off power, and on again.	P.49
5 blinking	5 blinking	Indoor control and Comma control error (power wiring error) is detected by outdoor unit.	Ed	① Check if connector (CNM) on outdoor controller board and outdoor power board is not always connected. ② Check if there is poor contact of connector on outdoor controller board (CMART and CMART).	P.49
		Indoor control and Comma control error (power wiring error) is detected by indoor unit.	AC-R	③ Check LAN communication status.	P.50~P.53

※1. Error code displayed on remote controller



Indication		Error				
LED1 (Green)	LED2 (Red)	Contents	Error code #1	Inspection method	Detailed reference page	
3 blinking	1 blinking	Abnormality of start thermistor (TH3) and discharge temperature (TH4)	U2	①Check if stop valves are open. ②Check if connectors (TH4, TH32, LEVA, and LEV-B) on outdoor controller board are not disconnected. ③Check if unit is filled with specified amount of refrigerant. ④Measure resistance values among terminals on indoor valve and outdoor linear expansion valve using a tester.	P.44	
		Abnormality of superheat (SH) before discharge temperature	U7		P.45	
	2 blinking	Abnormal high pressure (High pressure switch (HP) operated)	U1	①Check if indoor/outdoor units have a short cycle on their air ducts. ②Check if connector (63H) on outdoor controller board is not disconnected. ③Check if heat exchanger and filter is not dirty. ④Measure resistance values among terminals on linear expansion valve using a tester.	P.44	
		Abnormality of outdoor fan motor rotational speed	U8		P.46	
	4 blinking	Indoor fan output speed (TH1)	Ud	①Check the outdoor fan motor. ②Check if connector (TH3) on outdoor controller board is disconnected.	P.46	
		Compressor overcurrent breaking (Start-up locked)	UF			①Check if stop valves are open. ②Check looseness, disconnection, and converse connection of compressor wiring.
		Compressor overcurrent breaking (Start-up locked)	UP			③Measure resistance values among terminals on compressor using a tester.
	5 blinking	Abnormality of current sensor (P1)	UH	④Check if outdoor unit has a short cycle on its air duct.	P.47	
		Abnormality of power module	U6		P.45	
		Abnormality of indoor thermistor (TH1 and TH2) and outdoor thermistor (TH3)	U3	①Check if connectors (TH3, TH4, TH6, TH7 and TH32) on outdoor controller board and connector (CN3) on outdoor power board are not disconnected ③Measure resistance value of outdoor thermistors.	P.45	
6 blinking	Abnormality of heatsink temperature	Quantity of outdoor thermistor (TH1, TH2, TH3 and TH4)	U4		P.45	
		Abnormality of voltage	U9	①Check if indoor/outdoor units have a short cycle on their air ducts. ②Measure resistance value of outdoor thermistor (TH6).	P.45	
4 blinking	1 blinking	Looseness, disconnection, and converse connection of compressor wiring	U5	①Check looseness, disconnection, and converse connection of compressor wiring. ②Measure resistance value among terminals on compressor using a tester. ③Check the continuity of contactor (52C). ④Check if power supply voltage decreases. ⑤Check the wiring of CN52C. ⑥Check the wiring of CNAF.	P.46	
		Abnormality of indoor thermistor (TH1)	P1			①Check if connectors (CN20, CN21, CN29 and CN44) on indoor controller board are not disconnected.
		Abnormality of indoor thermistor (TH2)	P2			②Measure resistance value of indoor thermistors.
	2 blinking	Abnormality of indoor thermistor (TH3)	P9		※2	
		Abnormality of indoor thermistor (TH4)	P4	①Check if connector (CN31)(CN4F) on indoor controller board is not disconnected. ②Measure resistance value of indoor thermistors.	※2	
	3 blinking	Abnormality of indoor thermistor (TH5)	P5	③Measure resistance value among terminals on drain pump using a tester. ④Check if drain pump works. ⑤Check drain function.	※2	
		Abnormality of indoor thermistor (TH6)	P6	①Check if indoor unit has a short cycle on its air duct. ②Check if heat exchanger and filter is not dirty. ③Measure resistance value on indoor and outdoor fan motors. ④Check if the inside of refrigerant piping is not clogged.	※2	
	4 blinking	Abnormality of pipe temperature	Indoor drain overflow collection	P8	①Check if indoor thermistors (TH2 and TH5) are not disconnected from holder. ②Check if stop valve is open. ③Check converse connection of extension pipe. (on plural units connection) ④Check if indoor/outdoor connecting wire is connected correctly. (on plural units connection)	※2
			Abnormality of pipe temperature			

※1 Error code displayed on remote controller

※2 Refer to service manual for indoor unit.

11-6. HOW TO CHECK THE PARTS

PUHZ-P100VHA2.UK	PUHZ-P125VHA2.UK	PUHZ-P140VHA2.UK
PUHZ-P125VHA2.1.UK	PUHZ-P140VHA2.1.UK	
PUHZ-P100VHA3.UK	PUHZ-P125VHA3.UK	PUHZ-P140VHA3.UK
PUHZ-P100VHA3R1.UK	PUHZ-P125VHA3R1.UK	PUHZ-P140VHA3R1.UK
PUHZ-P100VHA3R2.UK	PUHZ-P125VHA3R2.UK	PUHZ-P140VHA3R2.UK
PUHZ-P100YHA.UK	PUHZ-P125YHA.UK	PUHZ-P140YHA.UK

Parts name	Check points														
Thermistor (TH3) <Outdoor pipe> Thermistor (TH4) <Discharge> Thermistor (TH6) <Outdoor pipe> Thermistor (TH7) <Outdoor> Thermistor (TH8) <Heatsink> Thermistor (TH32) <Comp.Surface>	Disconnect the connector then measure the resistance with a tester. (At the ambient temperature 10°C~30°C) <table border="1" style="margin-top: 10px;"> <thead> <tr> <th></th> <th>Normal</th> <th>Abnormal</th> </tr> </thead> <tbody> <tr> <td>TH4, TH32</td> <td>160kΩ~410kΩ</td> <td rowspan="4">Open or short</td> </tr> <tr> <td>TH3</td> <td rowspan="3">4.3kΩ~9.6kΩ</td> </tr> <tr> <td>TH6</td> </tr> <tr> <td>TH7</td> </tr> <tr> <td>TH8</td> <td>39kΩ~105kΩ</td> </tr> </tbody> </table>		Normal	Abnormal	TH4, TH32	160kΩ~410kΩ	Open or short	TH3	4.3kΩ~9.6kΩ	TH6	TH7	TH8	39kΩ~105kΩ		
	Normal	Abnormal													
TH4, TH32	160kΩ~410kΩ	Open or short													
TH3	4.3kΩ~9.6kΩ														
TH6															
TH7															
TH8	39kΩ~105kΩ														
Fan motor(MF1,MF2)	Refer to next page.														
Solenoid valve coil <Four-way valve> (Z1S4)	Measure the resistance between the terminals with a tester. (At the ambient temperature 20°C) <table border="1" style="margin-top: 10px;"> <thead> <tr> <th colspan="2">Normal</th> <th>Abnormal</th> </tr> </thead> <tbody> <tr> <td>P100, P125/140VHA2, P125/140VHA3(R1/R2), P125/140Y</td> <td>P125/P140VHA2</td> <td rowspan="2">Open or short</td> </tr> <tr> <td>1500 ± 150Ω</td> <td>1435 ± 150Ω</td> </tr> </tbody> </table>	Normal		Abnormal	P100, P125/140VHA2, P125/140VHA3(R1/R2), P125/140Y	P125/P140VHA2	Open or short	1500 ± 150Ω	1435 ± 150Ω						
Normal		Abnormal													
P100, P125/140VHA2, P125/140VHA3(R1/R2), P125/140Y	P125/P140VHA2	Open or short													
1500 ± 150Ω	1435 ± 150Ω														
Motor for charge pump (MC) 	Measure the resistance between the terminals with a tester. (Winding temperature 20°C) <table border="1" style="margin-top: 10px;"> <thead> <tr> <th colspan="4">Normal</th> <th>Abnormal</th> </tr> </thead> <tbody> <tr> <td>P100V</td> <td>P100Y</td> <td>P125/140V</td> <td>P125/140Y</td> <td rowspan="2">Open or short</td> </tr> <tr> <td>0.88Ω</td> <td>1.41Ω</td> <td>0.53Ω</td> <td>1.02Ω</td> </tr> </tbody> </table>	Normal				Abnormal	P100V	P100Y	P125/140V	P125/140Y	Open or short	0.88Ω	1.41Ω	0.53Ω	1.02Ω
Normal				Abnormal											
P100V	P100Y	P125/140V	P125/140Y	Open or short											
0.88Ω	1.41Ω	0.53Ω	1.02Ω												
Solenoid valve coil (LEV-A) 	Disconnect the connector then measure the resistance with a tester. (Winding temperature 20°C) <table border="1" style="margin-top: 10px;"> <thead> <tr> <th colspan="4">Normal</th> <th>Abnormal</th> </tr> </thead> <tbody> <tr> <td>Gray - Black</td> <td>Gray - Red</td> <td>Gray - Yellow</td> <td>Gray - Orange</td> <td rowspan="2">Open or short</td> </tr> <tr> <td colspan="4">46 ± 3Ω</td> </tr> </tbody> </table>	Normal				Abnormal	Gray - Black	Gray - Red	Gray - Yellow	Gray - Orange	Open or short	46 ± 3Ω			
Normal				Abnormal											
Gray - Black	Gray - Red	Gray - Yellow	Gray - Orange	Open or short											
46 ± 3Ω															
Solenoid valve coil <Bypass valve> (SV) for P125, 140	Measure the resistance between the terminals with a tester. (At the ambient temperature 20°C) <table border="1" style="margin-top: 10px;"> <thead> <tr> <th>Normal</th> <th>Abnormal</th> </tr> </thead> <tbody> <tr> <td>1450 ± 150Ω</td> <td>Open or short</td> </tr> </tbody> </table>	Normal	Abnormal	1450 ± 150Ω	Open or short										
Normal	Abnormal														
1450 ± 150Ω	Open or short														

Check method of DC fan motor (fan motor/outdoor controller circuit board)

① Notes

- High voltage is applied to the connector (CNF1, 2) for the fan motor. Pay attention to the service.
- Do not pull out the connector (CNF1, 2) for the motor with the power supply on.
(It causes trouble of the outdoor controller circuit board and fan motor.)

② Self check

Symptom : The outdoor fan cannot turn around.

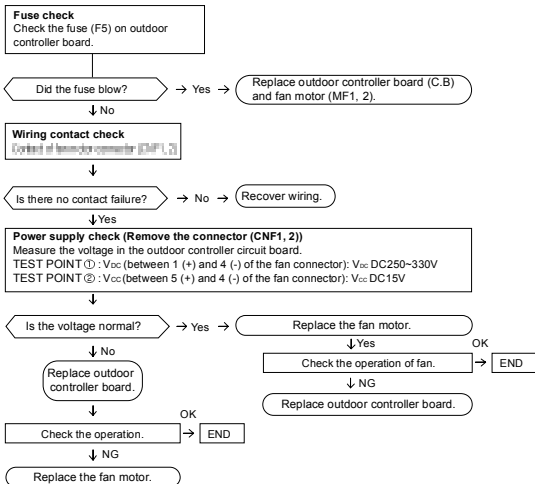

11-7. HOW TO CHECK THE COMPONENTS

<Thermistor feature chart>

Low temperature thermistors

- Thermistor <Outdoor pipe> (TH3)
- Thermistor <Outdoor 2-phase pipe> (TH6)
- Thermistor <Outdoor> (TH7)

Thermistor R0 = 15kΩ ± 3%
B constant = 3480 ± 2%

$$R_t = 15 \exp\left\{3480 \left(\frac{1}{273+t} - \frac{1}{273} \right)\right\}$$

0°C	15kΩ	30°C	4.3kΩ
10°C	9.6kΩ	40°C	3.0kΩ
20°C	6.3kΩ		
25°C	5.2kΩ		

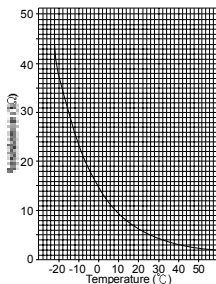

Medium temperature thermistor

- Thermistor <Heatsink> (TH8) (VHA2(1) / VHA3(R1) only)

Thermistor R50 = 17kΩ ± 2%
B constant = 4150 ± 3%

$$R_t = 17 \exp\left\{4150 \left(\frac{1}{273+t} - \frac{1}{323} \right)\right\}$$

0°C	180kΩ
25°C	50kΩ
50°C	17kΩ
70°C	8kΩ
90°C	4kΩ

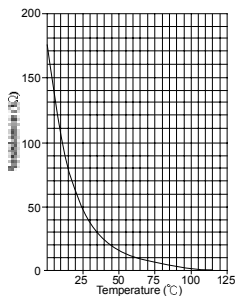

High temperature thermistor

- Thermistor <Discharge> (TH4) : VHA2(1) / VHA3(R1)
- Thermistor <Comp. Surface> (TH32) : VHA3R2, YHA

Thermistor R120 = 7.465kΩ ± 2%
B constant = 4057 ± 2%

$$R_t = 7.465 \exp\left\{4057 \left(\frac{1}{273+t} - \frac{1}{393} \right)\right\}$$

20°C	250kΩ	70°C	34kΩ
30°C	160kΩ	80°C	24kΩ
40°C	104kΩ	90°C	17.5kΩ
50°C	70kΩ	100°C	13.0kΩ
60°C	48kΩ	110°C	9.8kΩ

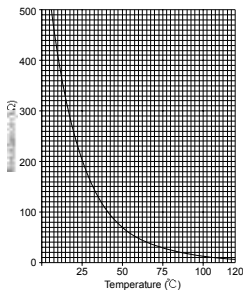

Linear expansion valve

(1) Operation summary of the linear expansion valve

- Linear expansion valve open/close through stepping motor after receiving the pulse signal from the outdoor controller board.
- Valve position can be changed in proportion to the number of pulse signal.

<Connection between the outdoor controller board and the linear expansion valve>

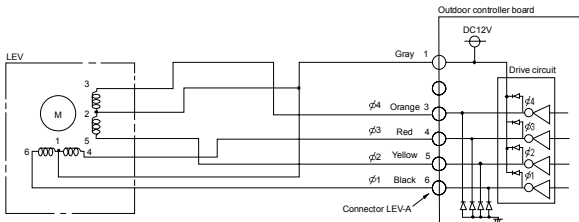

<Output pulse signal and the valve operation>

Output (Phase)	Output							
	1	2	3	4	5	6	7	8
φ1	ON	ON	OFF	OFF	OFF	OFF	OFF	ON
φ2	OFF	ON	ON	ON	OFF	OFF	OFF	OFF
φ3	OFF	OFF	OFF	ON	ON	ON	OFF	OFF
φ4	OFF	OFF	OFF	OFF	OFF	ON	ON	ON

Opening a valve : 8 → 7 → 6 → 5 → 4 → 3 → 2 → 1 → 8
 Closing a valve : 1 → 2 → 3 → 4 → 5 → 6 → 7 → 8 → 1

The output pulse shifts in above order.

- When linear expansion valve operation stops, all output phase become OFF.

- When the switch is turned on, 700 pulse closing valve signal will be sent till it goes to ② point in order to define the valve position. (The pulse signal is being sent for about 20 seconds.)

- When the valve moves smoothly, there is no sound or vibration occurring from the linear expansion valve : however, when the pulse number moves from ② to ③ or when the valve is locked, sound can be heard.

No sound is heard when the pulse number moves from ③ to ④ in case coil is burnt out or motor is locked by open-phase.

- Sound can be detected by placing the ear against the screw driver handle while putting the screw driver to the linear expansion valve.

(2) Linear expansion valve operation

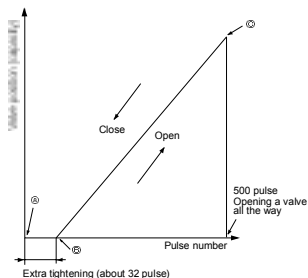

(3) How to attach and detach the coil of linear expansion valve

<Composition>

Linear expansion valve is separable into the main body and the coil as shown in the diagram below.

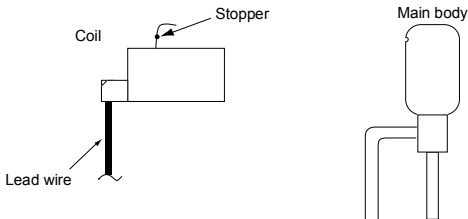

<How to detach the coil>

Hold the lower part of the main body (shown as A) firmly so that the main body does not move and detach the coil by pulling it upward.

Be sure to detach the coil holding main body firmly. Otherwise pipes can bend due to pressure.

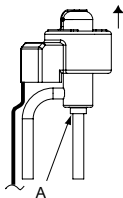

<How to attach the coil>

Hold the lower part of the main body (shown as A) firmly so that the main body does not move and attach the coil by inserting it downward into the main body. Then securely attach the coil stopper to main body. (At this time, be careful that stress is not added to lead wire and main body is not wound by lead wire.) If the stopper is not firmly attached to main body, coil may be detached from the main body and that can cause defective operation of linear expansion valve.

To prevent piping stress, be sure to attach the coil holding the main body of linear expansion valve firmly. Otherwise pipe may break.

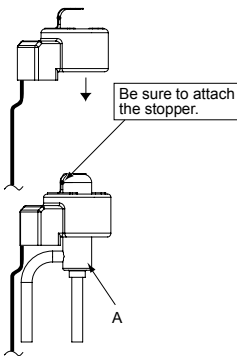

11-8. EMERGENCY OPERATION

(1) When the error codes shown below are displayed on outdoor unit or microcomputer for wired remote controller or indoor unit has a failure, but no other problems are found, emergency operation will be available by setting the emergency operation switch (SWE) on indoor controller board to ON and short-circuiting the connector (CN31) on outdoor controller board.

● When following abnormalities occur, emergency operation will be available.

Error code	Inspected content
U4	Open/short of pipe thermistor (TH3/TH6)
E8	Indoor/outdoor unit communication error • Signal receiving error (Outdoor unit)
E9	Indoor/outdoor unit communication error • Transmitting error (Indoor unit)
E0 ~ E7	Communication error other than outdoor unit
Ed	Communication error between outdoor controller board and M-NET board (Serial communication error)

(2) Check the following items and cautions for emergency operation

- ① Make sure that there is no abnormality in outdoor unit other than the above abnormalities. (Emergency operation will not be available when error code other than the above are indicated.)
- ② For emergency operation, it is necessary to set the emergency operation switch (SWE) on indoor controller board. Refer to the electrical wiring diagram of indoor unit for how to set the indoor unit.)
- ③ During emergency operation, the air-conditioner will continuously be operated by supplying power and stopping it: It can not be turned on or off by remote control, and temperature control is not possible.
- ④ Do not perform emergency heating operation for an extended period of time: If the outdoor unit starts defrosting during this period, cold air will blow out from the indoor unit.
- ⑤ Do not perform emergency cooling operation for more than 10 hours: Neglecting this could result in freezing the heat exchanger in indoor unit.

(3) Emergency operation procedure

- ① Turn the main power supply off.
- ② Turn on the emergency operation switch (SWE) on indoor controller board.
- ③ Set the shorting pins of emergency operation connector (CN31) on outdoor controller board to ON.
- ④ Use SW4-2 on outdoor controller board to set the operation mode (cooling or heating). (SW4-1 is not used.)

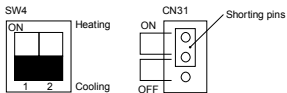

- ⑤ Turning the main power supply on will start the emergency operation.

(4) Releasing emergency operation

- ① Turn the main power supply off.
- ② Set the emergency operation switch (SWE) on indoor controller board to OFF.
- ③ Set the shorting pins of emergency operation connector (CN31) on outdoor controller board to OFF.
- ④ Set SW4-2 on outdoor controller board as shown in the right.

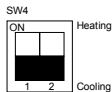

* If shorting pins are not set on emergency operation connector (CN31), the setting remains OFF.

(5) Operation data during emergency operation

During emergency operation, no communication is performed with the indoor unit, so the data items needed for operation are set to the following values:

Operation data	Operation mode		Remarks
	COOL	HEAT	
Intake temperature (TH1)	27°C	20.5°C	
Indoor liquid pipe temperature (TH2)	5°C	45°C	
Indoor 2-phase pipe temperature (TH5)	5°C	50°C	
Set temperature	25°C	22°C	
Outdoor fluid pipe temperature (TH3)	45°C	5°C	(※1)
Outdoor 2-phase pipe temperature (TH6)	50°C	5°C	(※1)
Outdoor air temperature (TH7)	35°C	5°C	(※1)
Temperature difference code (room temperature - set temperature)(Tj)	5	5	
Discharge superheat (SHd)	30deg	30deg	(※2)
Sub-cool (SC)	5deg	5deg	(※2)

※1 If the thermistor temperature data is normal (not open/short), that data is loaded into the control as valid data.

When the unit enters emergency operation and TH values are mismatched, set the thermistors to open/short.

And the unit runs emergency operation with the values listed above.

※2 If one thermistor is set to open/short, the value of SHd/SC will be different from the list above.

[Example] When liquid temperature thermistor (TH3) has an open or short circuit.

Thermistor	COOL	HEAT
TH3	45°C	5°C
TH6	Ta	Tb
	Regard normal figure as effective data.	
TH5	5°C	50°C
TH2	5°C	45°C

Degree of subcooling (SC)

Cooling = TH6 - TH3 = Ta - 45

Heating = TH5 - TH2 = 50 - 45 = 5 deg.

11-9. TEST POINT DIAGRAM

Outdoor controller circuit board

<CAUTION> CNF1 and CNF2 are high voltage.

PUHZ-P100VHA2.UK
PUHZ-P125VHA2.1.UK
PUHZ-P100VHA3.UK
PUHZ-P100VHA3R1.UK

PUHZ-P125VHA2.UK
PUHZ-P140VHA2.UK
PUHZ-P125VHA3.UK
PUHZ-P125VHA3R1.UK

PUHZ-P140VHA2.UK
PUHZ-P140VHA3.UK
PUHZ-P140VHA3R1.UK

SW1
Forced defrost,
detect history
record reset,
refrigerant address

SW7
Demand control setting

CNDM
① to ②: Input of low-level sound priority mode
① to ③: Input of external contact point

CN51
External signal output
• Compressor operating signal
• Abnormal signal

SW6
Model select

SW4
Test operator

SWP
pump down

SW5
Function switch,
model select

SW8
Pipe replace
Wiring replace

CNM
Connect to A control
service tool

CNMNT
Connect to

CNMNT
Connect to

LEV-A
Linear expansion
valve

TH4
Thermistor
<Discharge>

TH3
Thermistor
<Outdoor pipe>

TH7/6
Thermistor
<Outdoor/
2-phase pipe>

63H
High pressure
switch

V_{FG}
(Voltage between
right pins of PC5C
and PC5D, pin 3
and pin 4)
(Same as
(CNF1⑦(+)-⑧(-)))

V_{SP}
(Voltage between pins
of C5A, C5B); DC 0V
(when stopped), DC 1-
6.5V
(when operated)

CN4
Transmission to
outdoor power circuit
board (CN4)

SV1/CH
Crankcase heater
(P125, P140 only)

SV2
Bypass valve
(P125, P140 only)

21S4
Four-way valve

CN2
①-⑤: Reception from
①-⑤: Zero cross signal
(0-5V DC)
⑥-⑧: Not used
⑥-⑧: 16V DC
⑦-⑧: 16V DC

CNAC
② to ④: Power supply for
outdoor controller circuit
board (220V-240V AC)
① to ③: Power supply for
indoor and outdoor unit
connection wire
(220-240V AC)

CNS
S1-S2: 220-240V AC

CNDC
280V DC
(①+, ②-)
(Outdoor power board)

Communication power supply
D71 Voltage
24V DC

+

-

①-③: 250-330V DC
④-⑥: 15V DC
⑦-⑧: 0-6.5V DC
⑦-⑧: 15V DC(When stopped)
⑦-⑧: 7.5V DC(When operated)(0V-15V pulse)

①-⑤: Reception from

①-⑤: Zero cross signal

(0-5V DC)

⑥-⑧: Not used

⑥-⑧: 16V DC

⑦-⑧: 16V DC

② to ④: Power supply for

outdoor controller circuit

board (220V-240V AC)

① to ③: Power supply for

indoor and outdoor unit

connection wire

(220-240V AC)

S1-S2: 220-240V AC

280V DC

(①+, ②-)

(Outdoor power board)

Communication power supply

D71 Voltage

24V DC

+

-

①-③: 250-330V DC

④-⑥: 15V DC

⑦-⑧: 0-6.5V DC

⑦-⑧: 15V DC(When stopped)

⑦-⑧: 7.5V DC(When operated)(0V-15V pulse)

Outdoor controller circuit board

**PUHZ-P100VHA3R2.UK
PUHZ-P100YHA.UK**

**PUHZ-P125VHA3R2.UK
PUHZ-P125YHA.UK**

**PUHZ-P140VHA3R2.UK
PUHZ-P140YHA.UK**

<CAUTION> TEST POINT ① is high voltage.

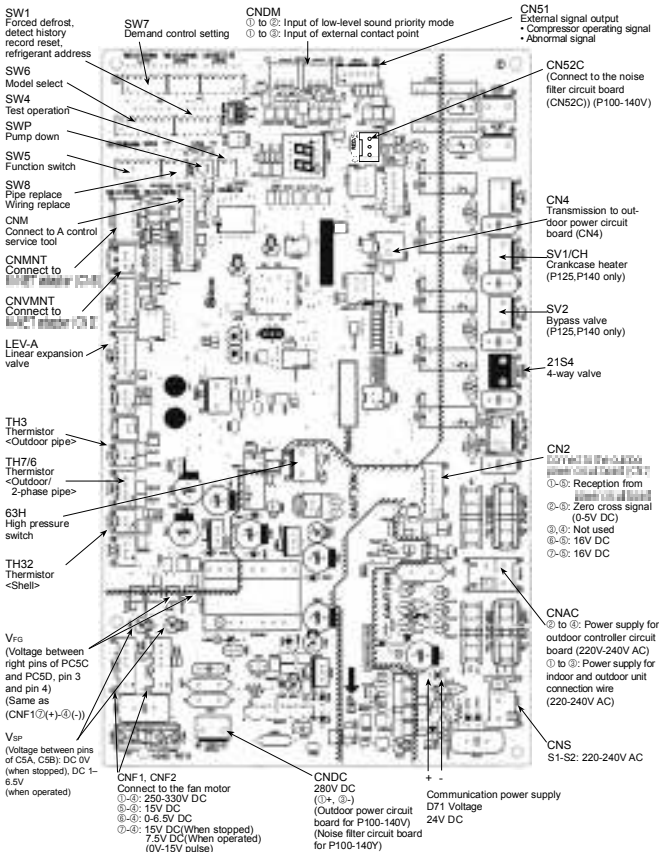

Mr. SLM

Outdoor noise filter circuit board

PUHZ-P100VHA2.UK

PUHZ-P125VHA2.UK

PUHZ-P140VHA2.UK

PUHZ-P125VHA2i.UK

PUHZ-P140VHA2i.UK

PUHZ-P100VHA3.UK

PUHZ-P125VHA3.UK

PUHZ-P125VHA3.UK

PUHZ-P100VHA3R1.UK

PUHZ-P125VHA3R1.UK

PUHZ-P125VHA3R1.UK

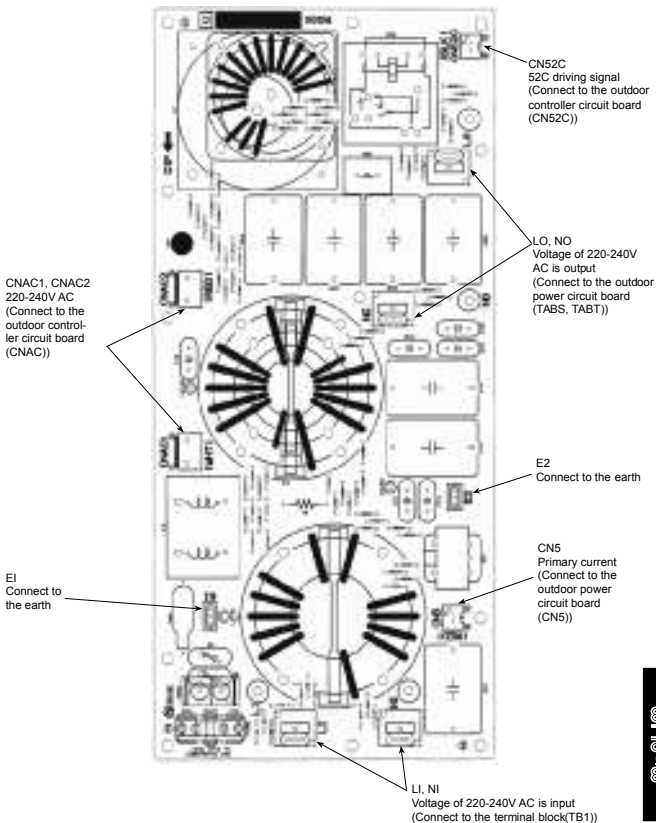

Outdoor noise filter circuit board

PUHZ-P100YHA.UK

PUHZ-P125YHA.UK

PUHZ-P140YHA.UK

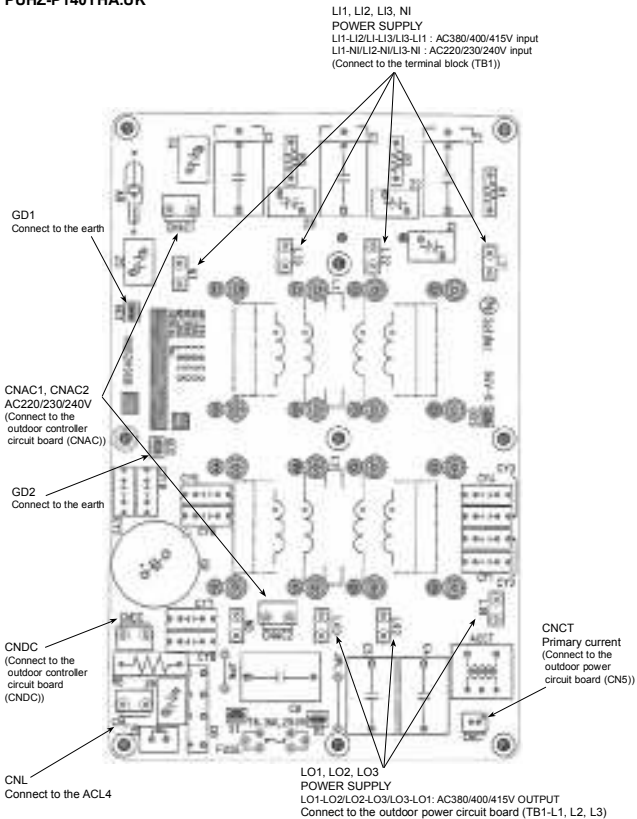

Outdoor power circuit board

PUHZ-P100VHA2.UK

PUHZ-P125VHA2.UK

PUHZ-P140VHA2.UK

PUHZ-P125VHA2₁.UKPUHZ-P140VHA2₁.UK

PUHZ-P100VHA3.UK

PUHZ-P125VHA3.UK

PUHZ-P140VHA3.UK

PUHZ-P100VHA3R1.UK

PUHZ-P125VHA3R1.UK

PUHZ-P140VHA3R1.UK

Brief Check of POWER MODULE

※ Usually, they are in a state of being short-circuited if they are broken. Measure the resistance in the following points (connectors, etc.).

If they are short-circuited, it means that they are broken.

1. Check of diode bridge (DS2, DS3)

TABP1-TABS, TABN1-TABS, TABP1-TABT, TABN1-TABT

2. Check of DIP-IPM

P-U, P-V, P-W, N-U, N-V, N-W

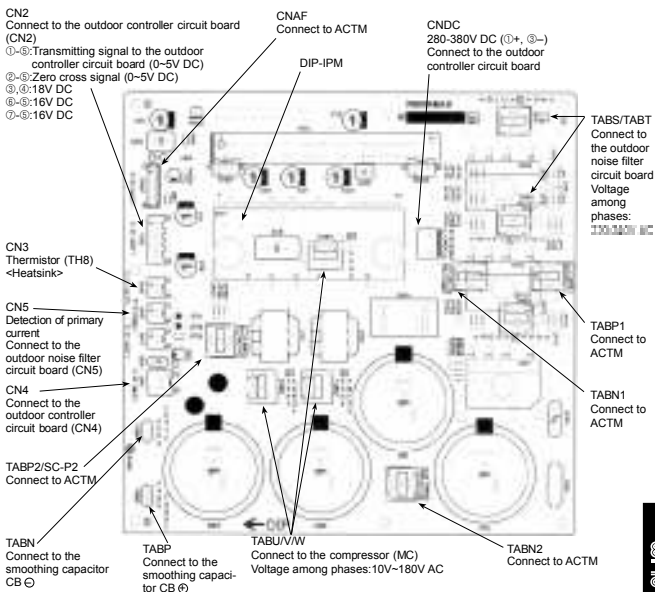

Outdoor power circuit board

PUHZ-P100VHA3R2.UK

PUHZ-P125VHA3R2.UK

PUHZ-P140VHA3R2.UK

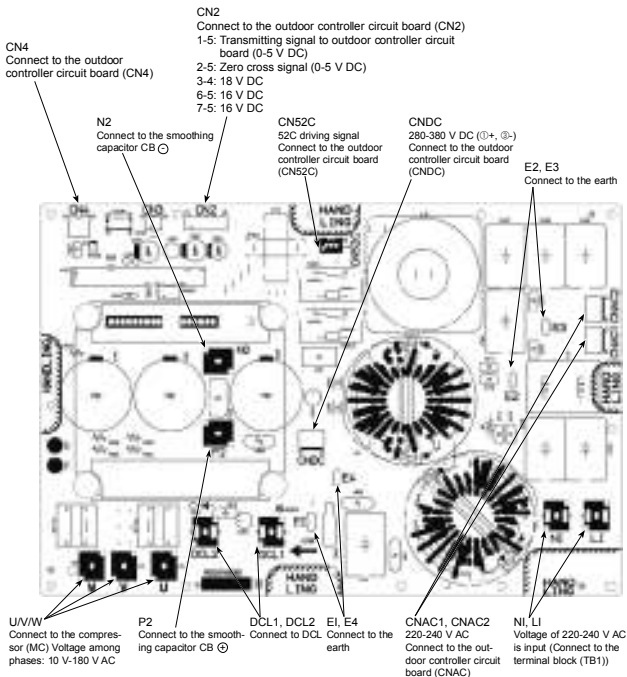

Outdoor power circuit board
PUHZ-P100YHA.UK
PUHZ-P125YHA.UK
PUHZ-P140YHA.UK

Brief Check of POWER MODULE

※ Usually, they are in a state of being short-circuited if they are broken. Measure the resistance in the following points (connectors, etc.). If they are short-circuited, it means that they are broken.

1. Check of POWER MODULE

①. Check of DIODE circuit

L1 - P1, L2 - P1, L3 - P1, L1 - N1, L2 - N1, L3 - N1

②. Check of IGBT circuit

P2 - U, P2 - V, P2 - W, N2 - U, N2 - V, N2 - W

Note: The marks, L1, L2, L3, N1, N2, P1, P2, U, V and W shown in the diagram are not actually printed on the board.

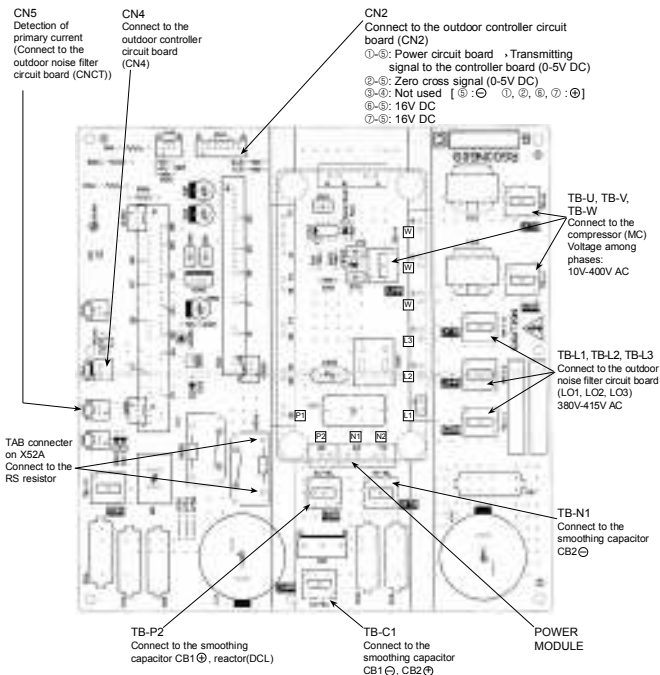

Active filter module

PUHZ-P100VHA2.UK
 PUHZ-P125VHA2(1).UK
 PUHZ-P140VHA2(1).UK

PUHZ-P100VHA3.UK
 PUHZ-P125VHA3.UK
 PUHZ-P140VHA3.UK

PUHZ-P100VHA3R1.UK
 PUHZ-P125VHA3R1.UK
 PUHZ-P140VHA3R1.UK

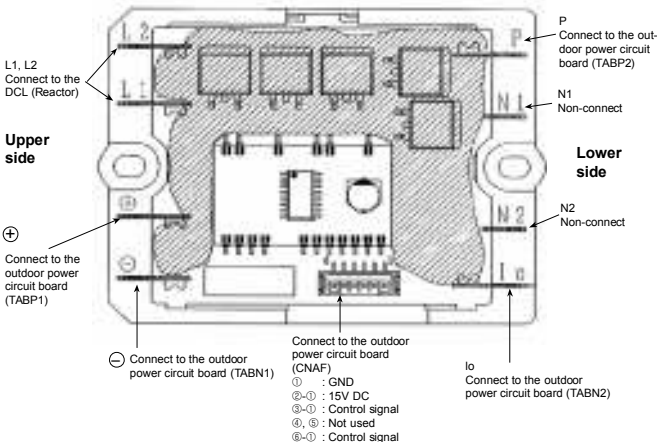

Connection and internal circuit diagram

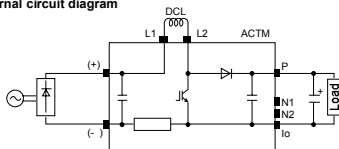

Tester check points of Active filter module

	Test condition	Normal value (reference)	Symptom when the unit is in trouble
(-) and lo	open	less than 1Ω	① The unit does not operate (can not be switched ON)
	short	100kΩ ~ 1MΩ	① The breaker operates
(-) and L2	open	※1	② The unit does not operate (can not be switched ON) ③ UR Abnormal stop ※2
	short	100kΩ ~ 1MΩ	① The breaker operates
P and L2	open	※1	② The unit does not operate (can not be switched ON) ③ UR Abnormal stop ※2
	short	100kΩ ~ 1MΩ	① The breaker operates
P and lo	open	※1	② The unit does not operate (can not be switched ON) ③ UR Abnormal stop ※2
	short	100kΩ ~ 1MΩ	① The breaker operates
L2 and lo	open	※1	② The unit does not operate (can not be switched ON) ③ UR Abnormal stop ※2
	short	100kΩ ~ 1MΩ	① The breaker operates

※1 The symptom when the unit is in open error condition is described to determine open error by tester check.

※2 SW2 setting ON : Code "20" display
 OFF

<Display function of inspection for outdoor unit>

The blinking patterns of both LED1 (green) and LED2 (red) indicate the types of abnormality when it occurs. Types of abnormality can be indicated in details by connecting an optional part 'A-Control Service Tool (PAC-SK52ST)' to connector CNM on outdoor controller board.

[Display]**(1) Normal condition**

Unit condition	Outdoor controller board		A-Control Service Tool	
	LED1 (Green)	LED2 (Red)	Error code	Indication of the display
When the power is supplied	Lighted	Lighted	— ↔ —	Alternately blinking display
When unit stops	Lighted	Not lighted	00, etc.	Operation mode
When component is starting up	Lighted	Not lighted	08, etc.	
When unit operates	Lighted	Lighted	C5, H7 etc.	

(2) Abnormal condition

Indication		Error				
Outdoor controller board	Indoor Unit	Contents	Error code ※1	Inspection method	Detailed reference page	
1 blinking	2 blinking	Connector(63H) is open.	F5	①Check if connector (63H) on the outdoor controller board is not disconnected. ②Check continuity of power switch (63H) in leader.	P.38	
2 blinking	1 blinking	Missing of indoor/outdoor unit control. (Display shows number of indoor unit or 0)	—	①Check if indoor/outdoor connecting wire is connected correctly. ②Check if 4 or more indoor units are connected to outdoor unit. ③Check if noise entered into indoor/outdoor connecting wire or power supply. ④Re-check error by turning off power, and on again.	P.39 (EA)	
		Miswiring of indoor/outdoor unit connecting wire (converse wiring or disconnection)	—			P.39 (Eb)
	Startup time over	—	P.39 (EC)			
	2 blinking	2 blinking	Indoor unit and 1 indoor unit are connected to indoor/outdoor connecting wire on outdoor unit.		E6	①Check if indoor/outdoor connecting wire is connected correctly. ②Check if noise entered into indoor/outdoor connecting wire or power supply. ③Check if noise entered into indoor/outdoor connecting wire. ④Re-check error by turning off power, and on again.
Indoor unit and 1 indoor unit are connected to indoor/outdoor connecting wire on outdoor unit.			E7	※2		
Indoor unit and 1 indoor unit are connected to indoor/outdoor connecting wire on outdoor unit.			—	P.44 (E8)		
3 blinking	1 blinking	Remote controller signal receiving error is detected by remote controller.	E0	①Check if connecting wire of indoor unit or remote controller is connected correctly. ②Check if noise entered into transmission wire of remote controller. ③Re-check error by turning off power, and on again.	P.43	
		Remote controller transmitting error is detected by remote controller.	E3			P.44
		Remote controller signal receiving error is detected by indoor unit.	E4			P.43
		Remote controller transmitting error is detected by indoor unit.	E5			P.44
4 blinking	1 blinking	Error code is not defined.	EF	①Check if remote controller is MA remote controller (PAC-2144). ②Check if noise entered into transmission wire of remote controller. ③Check if noise entered into indoor/outdoor connecting wire. ④Re-check error by turning off power, and on again.	P.44	
5 blinking	1 blinking	Indoor unit and 1 indoor unit are connected to indoor/outdoor connecting wire on outdoor controller board.	Ed	①Check if connector (CNM) on outdoor controller board and outdoor power board is not disconnected. ②Check if there is poor connection of connector on outdoor controller board (CNM1 and CNM2). ③Check LAN-E communication signal.	P.44	
		Communicative error of LLUFT system	A0-A8			P.45~P.48

※1 Error code is displayed on remote controller.

※2 Refer to service manual for indoor unit.

Indication		Contents	Error code #1	Error	Inspection method	Detailed reference page
LED1 (Green)	LED2 (Red)					
3 blinking	1 blinking	Abnormality of start thermistor and discharging temperature (T4)	U2	① Check if stop valves are open. ② Check if connectors (TH4, LEV-A) on outdoor controller board are not disconnected. ③ Check if unit fills with specified amount of refrigerant. ④ Measure resistance values among terminals on indoor valve and outdoor linear expansion valve using a tester.		P.40
	2 blinking	Abnormal high pressure (High pressure switch ESH operated)	U1	① Check if indoor/outdoor units have a short cycle on their air ducts. ② Check if connector (ESH) on outdoor controller board is not disconnected. ③ Check if heat exchanger and filter are not dirty. ④ Measure resistance values among terminals on linear expansion valve using a tester.		P.40
	3 blinking	Abnormality of outdoor fan motor rotational speed	U8	① Check the outdoor fan motor. ② Check if the connector of TH3 on outdoor controller board is disconnected.		P.42
	4 blinking	Compressor normal lockup (Set rotated) Compressor over current locking Abnormality of indoor sensor (P1) Abnormality of power module	Ud	① Check if stop valves are open.		P.42
			UF	② Check looseness, disconnection, and converse connection of compressor wiring.		P.43
			UH	③ Measure resistance values among terminals on compressor using a tester.		P.42
			U6	④ Check if outdoor unit has a short cycle on its air duct.		P.41
5 blinking	Operational stoppage (TH3, TH4, TH5, TH6, TH7, TH8) Operational stoppage (TH3, TH4, TH5, TH6, TH7, TH8)	U3	① Check if connectors (TH3, TH4 or TH32, TH6 and TH7) on outdoor controller board and connector (CN3) on outdoor power board are not disconnected.		P.41	
		U4	② Measure resistance value of outdoor thermistors.		P.41	
6 blinking	Abnormality of heatsink temperature	U5	① Check if indoor/outdoor units have a short cycle on their air ducts. ② Measure resistance value of outdoor thermistor (TH8).		P.41	
7 blinking	Abnormality of voltage	U9	① Check looseness, disconnection, and converse connection of compressor wiring. ② Measure resistance value among terminals on compressor using a tester. ③ Check the continuity of contactor (52C). ④ Check if power supply voltage decreases. ⑤ Check the wiring of CNAF.		P.42	
4 blinking	1 blinking	Abnormality of indoor/outdoor connector (CN20, CN21, CN29 and CN44)	P1	① Check if connectors (CN20, CN21, CN29 and CN44) on indoor controller board are not disconnected.		※2
		Abnormality of indoor/outdoor connector (CN20, CN21, CN29 and CN44)	P2	② Measure resistance value of indoor thermistors.		※2
		Abnormality of room temperature thermistor (CN20 and CN29) Compressor	P9			※2
	2 blinking	Abnormality of heat sensor (P5) Final switch (P5) connector open Indoor drain overflow obstruction	P4	① Check if connector (CN31)(CN4F) on indoor controller board is not disconnected. ② Measure resistance value of indoor thermistors.		※2
			P5	③ Measure resistance value among terminals on drain-up machine using a tester. ④ Check if drain-up machine works. ⑤ Check drain function.		
	3 blinking	Freezing (cooling) of heat exchanger (heat exchanger is restricted)	P6	① Check if indoor unit has a short cycle on its air duct. ② Check if heat exchanger and filter is not dirty. ③ Measure resistance value on indoor and outdoor fan motors. ④ Check if the inside of refrigerant piping is not clogged.		※2
	4 blinking	Abnormality of pipe temperature	P8	① Check if indoor thermistors (TH2 and TH5) are not disconnected from holder. ② Check if stop valve is open. ③ Check converse connection of extension pipe. (on plural units connection) ④ Check if indoor/outdoor connecting wire is connected correctly. (on plural units connection)		※2

※1 Error code displayed on remote controller
 ※2 Refer to service manual for indoor unit.



10-6. HOW TO CHECK THE PARTS

PUH-P71VHA.UK PUH-P100VHA.UK

PUH-P71YHA.UK PUH-P100YHA.UK PUH-P125YHA.UK PUH-P140YHA.UK

PU-P71VHA.UK PU-P100VHA.UK

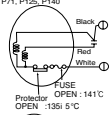
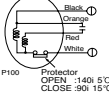
PU-P71YHA.UK PU-P100YHA.UK PU-P125YHA.UK PU-P140YHA.UK

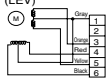
Parts name	Check points														
Thermistor (TH3) <Outdoor pipe> Thermistor (TH4) <Discharge> Thermistor (TH6) <Outdoor 2-phase pipe>	Disconnect the connector then measure the resistance using a tester. (Surrounding temperature 10°C~30°C) <table border="1"> <thead> <tr> <th></th> <th>Normal</th> <th>Abnormal</th> </tr> </thead> <tbody> <tr> <td>TH4</td> <td>160Ω ~410Ω</td> <td rowspan="3">Open or short</td> </tr> <tr> <td>TH3</td> <td>4.3Ω ~9.6Ω</td> </tr> <tr> <td>TH6</td> <td></td> </tr> </tbody> </table>		Normal	Abnormal	TH4	160Ω ~410Ω	Open or short	TH3	4.3Ω ~9.6Ω	TH6					
	Normal	Abnormal													
TH4	160Ω ~410Ω	Open or short													
TH3	4.3Ω ~9.6Ω														
TH6															
FAN MOTOR(MF) P71, P125, P140  	Measure the resistance between the terminals using a tester. (Surrounding temperature 20°C) <table border="1"> <thead> <tr> <th rowspan="2">Motor lead wire</th> <th colspan="2">Normal</th> <th rowspan="2">Abnormal</th> </tr> <tr> <th>P71, P125, P140</th> <th>P100</th> </tr> </thead> <tbody> <tr> <td>White — Black</td> <td>82.5Ω ±10%</td> <td>44.5Ω ±7%</td> <td rowspan="2">Open or short</td> </tr> <tr> <td>White — Red</td> <td>102.0Ω ±10%</td> <td>43.7Ω ±7%</td> </tr> </tbody> </table>	Motor lead wire	Normal		Abnormal	P71, P125, P140	P100	White — Black	82.5Ω ±10%	44.5Ω ±7%	Open or short	White — Red	102.0Ω ±10%	43.7Ω ±7%	
Motor lead wire	Normal		Abnormal												
	P71, P125, P140	P100													
White — Black	82.5Ω ±10%	44.5Ω ±7%	Open or short												
White — Red	102.0Ω ±10%	43.7Ω ±7%													
Solenoid valve coil <Four-way valve> (21S4)	Measure the resistance between the terminals using a tester. (Surrounding temperature 20°C) <table border="1"> <thead> <tr> <th colspan="2">Normal</th> <th>Abnormal</th> </tr> </thead> <tbody> <tr> <td>P71,P100</td> <td>P125,P140</td> <td rowspan="2">Open or short</td> </tr> <tr> <td>1500±150Ω</td> <td>1435±150Ω</td> </tr> </tbody> </table>	Normal		Abnormal	P71,P100	P125,P140	Open or short	1500±150Ω	1435±150Ω						
Normal		Abnormal													
P71,P100	P125,P140	Open or short													
1500±150Ω	1435±150Ω														
Motor for compressor (MC) 	Measure the resistance between the terminals using a tester. (Winding temperature 20°C) <table border="1"> <thead> <tr> <th>Normal</th> <th>Abnormal</th> </tr> </thead> <tbody> <tr> <td>Refer to 5-2.</td> <td>Open or short</td> </tr> </tbody> </table>	Normal	Abnormal	Refer to 5-2.	Open or short										
Normal	Abnormal														
Refer to 5-2.	Open or short														
Linear expansion valve (LEV) 	Disconnect the connector then measure the resistance using a tester. (Winding temperature 20°C) <table border="1"> <thead> <tr> <th colspan="4">Normal</th> <th>Abnormal</th> </tr> </thead> <tbody> <tr> <td>Gray - Black</td> <td>Gray - Red</td> <td>Gray - Yellow</td> <td>Gray - Orange</td> <td rowspan="2">Open or short</td> </tr> <tr> <td colspan="4">46±3Ω</td> </tr> </tbody> </table>	Normal				Abnormal	Gray - Black	Gray - Red	Gray - Yellow	Gray - Orange	Open or short	46±3Ω			
Normal				Abnormal											
Gray - Black	Gray - Red	Gray - Yellow	Gray - Orange	Open or short											
46±3Ω															
Solenoid valve coil <Bypass valve> (SV) For P125, P140	Measure the resistance between the terminals using a tester. (Surrounding temperature 20°C) <table border="1"> <thead> <tr> <th>Normal</th> <th>Abnormal</th> </tr> </thead> <tbody> <tr> <td>1450±150Ω</td> <td>Open or short</td> </tr> </tbody> </table>	Normal	Abnormal	1450±150Ω	Open or short										
Normal	Abnormal														
1450±150Ω	Open or short														
CRNKCASE HEATER (CH)	Measure the resistance between the terminals using a tester. <table border="1"> <thead> <tr> <th>Normal</th> <th>Abnormal</th> </tr> </thead> <tbody> <tr> <td>P71,P100,P125,P140</td> <td rowspan="2">Open or short</td> </tr> <tr> <td>2304Ω ±7%</td> </tr> </tbody> </table>	Normal	Abnormal	P71,P100,P125,P140	Open or short	2304Ω ±7%									
Normal	Abnormal														
P71,P100,P125,P140	Open or short														
2304Ω ±7%															

10-7. HOW TO CHECK THE COMPONENTS

<Thermistor feature chart>

Low temperature thermistors

- Thermistor <Outdoor pipe> (TH3)
- Thermistor <Outdoor 2-phase pipe> (TH6)

Thermistor R0 = 15k \pm 3%B constant = 3480 \pm 2%

$$R_t = 15 \exp\left(3480 \left(\frac{1}{273+t} - \frac{1}{273} \right)\right)$$

0°C	15k Ω	30°C	4.3k Ω
10°C	9.6k Ω	40°C	3.0k Ω
20°C	6.3k Ω		
25°C	5.2k Ω		

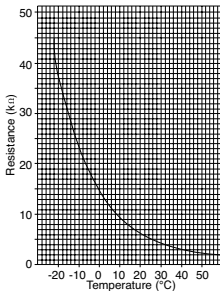

High temperature thermistor

- Thermistor <Discharge> (TH4)

Thermistor R120 = 7.465k $\Omega \pm$ 2%B constant = 4057 \pm 2%

$$R_t = 7.465 \exp\left(4057 \left(\frac{1}{273+t} - \frac{1}{393} \right)\right)$$

20°C	250k Ω	70°C	34k Ω
30°C	160k Ω	80°C	24k Ω
40°C	104k Ω	90°C	17.5k Ω
50°C	70k Ω	100°C	13.0k Ω
60°C	48k Ω	110°C	9.8k Ω

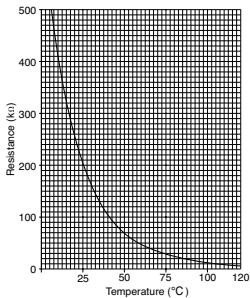

Linear expansion valve

(1) Operation summary of the linear expansion valve.

- Linear expansion valve open/close through stepping motor after receiving the pulse signal from the outdoor controller board.
- Valve position can be changed in proportion to the number of pulse signal.

<Connection between the indoor controller board and the linear expansion valve>

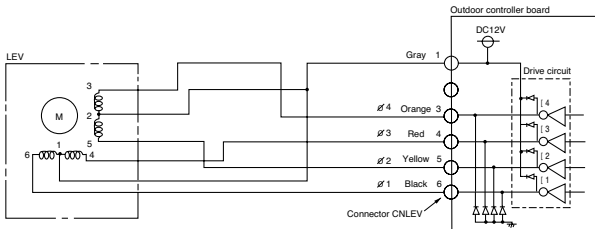

<Output pulse signal and the valve operation>

Output (Phase)	Output							
	1	2	3	4	5	6	7	8
φ 1	ON	ON	OFF	OFF	OFF	OFF	OFF	ON
φ 2	OFF	ON	ON	ON	OFF	OFF	OFF	OFF
φ 3	OFF	OFF	OFF	ON	ON	ON	OFF	OFF
φ 4	OFF	OFF	OFF	OFF	OFF	ON	ON	ON

Opening a valve : 8 → 7 → 6 → 5 → 4 → 3 → 2 → 1 → 8

Closing a valve : 1 → 2 → 3 → 4 → 5 → 6 → 7 → 8 → 1

The output pulse shifts in above order.

※ 1. When linear expansion valve operation stops, all output phase become OFF.

※ When the switch is turned on, 700 pulse closing valve signal will be sent till it goes to A point in order to define the valve position. (The pulse signal is being sent for about 20 seconds.)

(2) Linear expansion valve operation

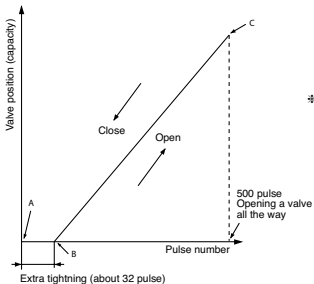

When the valve moves smoothly, there is no noise or vibration occurring from the linear expansion valve : however, when the pulse number moves from B to A or when the valve is locked, more noise can be heard than normal situation.

No noise is heard when the pulse number moves from B to A in case coil is burn out or motor is locked by open-phase.

※ Noise can be detected by placing the ear against the screw driver handle while putting the screw driver to the linear expansion valve.

(3) How to attach and detach the coil of linear expansion valve

<Composition>

Linear expansion valve is separable into the main body and the coil as shown in the diagram below.

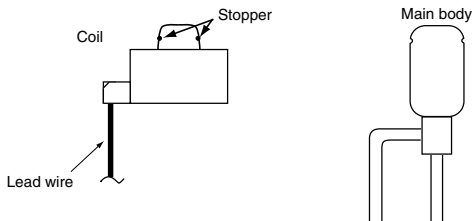

<How to detach the coil>

Hold the lower part of the main body (shown as A) firmly so that the main body does not move and detach the coil by pulling it upward.

Be sure to detach the coil holding main body firmly. Otherwise pipes can bend due to pressure.

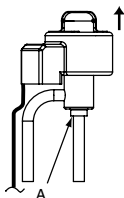

<How to attach the coil>

Hold the lower part of the main body (shown as A) firmly so that the main body does not move and attach the coil by inserting it downward into the main body. Then securely attach the coil stopper to main body. (At this time, be careful that stress is not added to lead wire and main body is not wound by lead wire.) If the stopper is not firmly attached to main body, coil may be detached from the main body and that can cause defective operation of linear expansion valve.

To prevent piping stress, be sure to attach the coil holding the main body of linear expansion valve firmly. Otherwise pipe may break.

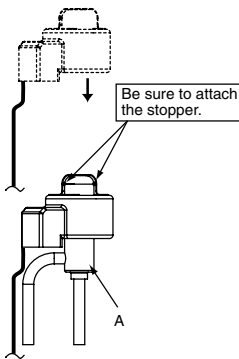

8. TEST POINT DIAGRAM

● Outdoor controller board

PUH-P71VHA.UK PUH-P100VHA.UK

PUH-P71YHA.UK PUH-P100YHA.UK PUH-P125YHA.UK PUH-P140YHA.UK

PU-P71VHA.UK PU-P100VHA.UK

PU-P71YHA.UK PU-P100YHA.UK PU-P125YHA.UK PU-P140YHA.UK

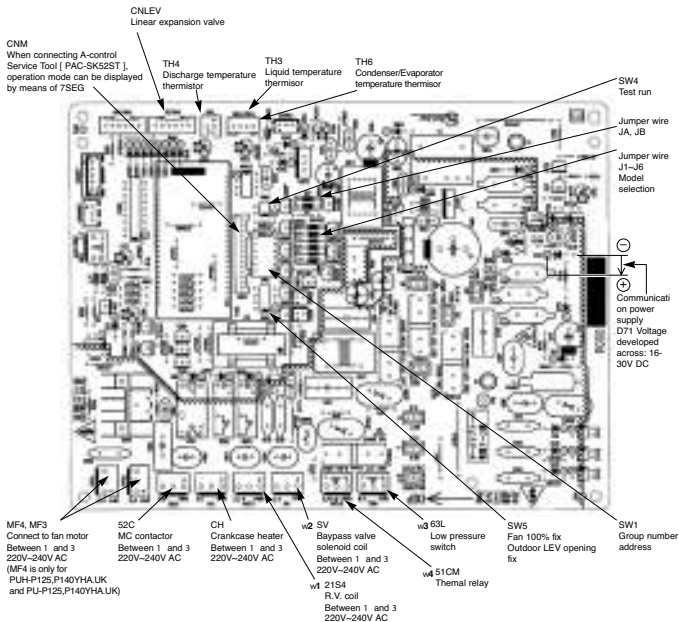

⚡ 1. 21S4 is only for PUH-P71, P100VHA.UK and PUH-P71, P100, P125, P140YHA.UK.

⚡ 2. SV is only for PUH-P125, P140YHA.UK and PU-P125, P140YHA.UK.

⚡ 3. 63L is only for PUH-P125, P140YHA.UK and PU-P125, P140YHA.UK.

⚡ 4. Thermal relay is only for PU(H)-P71, P100, P125, P140YHA.UK.



FUNCIONES

Mr.SLIM

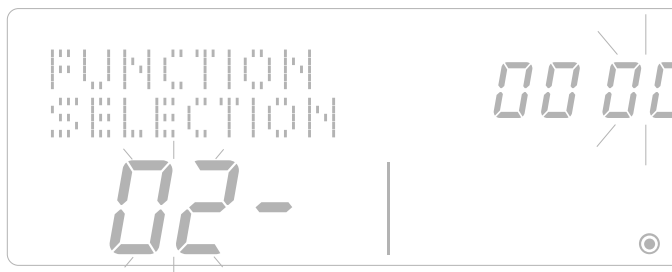

<Función de monitoreo de operación de la unidad exterior>

[Cuando se conecta la parte opcional "Herramienta de Servicio Control-A" (PAC-SK52ST) a la placa controladora exterior (CNM)]

El indicador digital LED1 exhibe 2 dígitos o código para informar la condición de operación y el significado del código de error controlando el DIP SW2 en la "Herramienta de Servicio Control-A".

Indicador de operación SW2: Cambio de indicador de autodiagnóstico

Configuración de SW2	Detalles del display	Explicación del display	Unidad
			

<Detalle de trabajo del indicador digital LED1>

(Asegúrese de que estén apagados 1 a 6 del SW2).

- Display cuando está encendida la alimentación.
Cuando está encendida la alimentación, el display parpadea en turnos.
Espere 4 minutos como máximo.
- Cuando el display se enciende. (Operación normal)
1 Display de modo de operación.

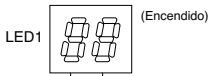

Dígito de decenas: Modo de operación

Display	Modo de operación
O	APAGADO / VENTILADOR
C	REFRIGERACIÓN / SECADO *
H	CALEFACCIÓN
d	DESESCARCHADO

Dígito de unidades: Salida del relé

Display	Prealimentando al compresor	Compresor	Válvula de 4 vías	Válvula solenoide
0	-	-	-	-
1	-	-	-	ON
2	-	-	ON	-
3	-	-	ON	ON
4	-	ON	-	-
5	-	ON	-	ON
6	-	ON	ON	-
7	-	ON	ON	ON
8	ON	-	-	-
A	ON	-	ON	-

2 Display durante la posición del error

El código de posición se exhibe cuando el compresor se detiene debido al trabajo del dispositivo de protección.

El código de postergación se exhibe mientras que el error es pospuesto.

- Cuando el display parpadea







El código de inspección se exhibe cuando el compresor se detiene debido al accionar de los dispositivos de protección.



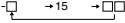

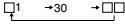

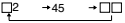

Display	Contenido a ser inspeccionado (Durante la operación)
U1	Alta presión anormal (accionó 63H)
U2	Temperatura de descarga anormal alta, falta de refrigerante
U3	Termistor de descarga abierto/corto (TH4)
U4	Termistores de la unidad exterior abiertos/corto (TH3, TH32, TH6, TH7 y TH8)
U5	Temperatura anormal del disipador Interrupción por sobrecorriente del compresor (Cuando el compresor está bloqueado)
U6	Anormalidad del módulo de alimentación
U7	Anormalidad de sobrecalentamiento debido a baja temperatura de descarga
UH	Interrupción por sobrecorriente del compresor (Cuando el compresor está bloqueado)
UL	Error del sensor de corriente
UL	Baja presión anormal (accionó 63L)
UP	Interrupción por sobrecorriente del compresor
P1-P8	Anormalidad de unidades interiores
A0-A7	Error de comunicación de señal de alta prioridad (M-NET)

Display	Unidad inspeccionada
0	Unidad exterior
1	Unidad interior 1
2	Unidad interior 2
3	Unidad interior 3
4	Unidad interior 4









Display	Contenidos a ser inspeccionados (Cuando la alimentación está apagada)
F3	Conector 63L (rojo) abierto.
F5	Conector 63H (amarillo) abierto.
F9	Ambos conectores (63H/63L) abiertos.
E8	Error de comunicación interior/exterior (Error de recepción de señal) (Unidad exterior)
E9	Error de comunicación interior/exterior (Error de transmisión) (Unidad exterior)
EA	Error de cableado del cable de conexión interior/exterior, cantidad excesiva de unidades interiores (5 o más unidades)
Eb	Error de cableado del cable de conexión interior/exterior (cable invertido o desconexión)
Ec	Sobrepaso del tiempo de arranque
E0-E7	Error de comunicación excepto la unidad exterior

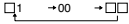





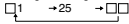

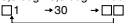

Configuración de SW2	Detalle del display	Explicación del display	Unidad
	Temperatura de cañería de líquido (TH3) -40 a 90	-40 a 90 (Cuando el termistor de serpentina detecta 0° o inferior, se exhiben en forma alternada "-" y la temperatura) (Ejemplo) Cuando -10°C; 0,5 seg. 0,5 seg. 2seg. -□ → 10 → □□	°C
	Temperatura de descarga (TH4) 3 a 217	3-217 (Cuando el termistor de descarga detecta 100° o superior, se exhiben en forma alternada las centenas, decenas y unidades) (Ejemplo) Cuando 105°C; 0,5 seg. 0,5 seg. 2seg. □1 → 05 → □□	°C
	Paso del ventilador exterior 0 a 10	0~10	paso
	Cantidad de encendidos/apagados del compresor 0 a 9999	0-9999 (Cuando la cantidad de veces es 100 o superior, se exhiben en forma alternada las centenas, decenas y unidades) (Ejemplo) Cuando 42500 veces (425 × 100 veces) 0,5 seg. 0,5 seg. 2seg. □4 → 25 → □□	100 veces
	Tiempo integrado de operación del compresor 0 a 9999	0-9999 (Cuando son 100 horas o mas, se exhiben en forma alternada las centenas, decenas y unidades) (Ejemplo) Cuando 2450 horas (245 × 10 horas) 0,5 seg. 0,5 seg. 2seg. □2 → 45 → □□	10 horas
	Corriente de operación del compresor 0 a 50	0~50 * Omite las cifras después de la fracción decimal.	A
	Frecuencia de operación del compresor 0 a 225	0-255 (Cuando es 100 Hz o mas, se exhiben en forma alternada las centenas, decenas y unidades) (Ejemplo) Cuando 125 Hz; 0,5 seg. 0,5 seg. 2seg. □1 → 25 → □□	Hz
	Pulso de apertura de la VEL-A 0 a 480	0-480 (Cuando es 100 pulsos o mas, se exhiben en forma alternada las centenas, decenas y unidades) (Ejemplo) Cuando 150 pulsos; 0,5 seg. 0,5 seg. 2seg. □1 → 50 → □□	Pulso
	Historia del código de error de postergación (1) de la unidad exterior	Display de código de postergación Parpadeando: Durante postergación Encendido: Cancelación de la postergación "00" se exhibe en caso de no postergación.	Exhibe el código
	Modo de operación al ocurrir el error	Modo de operación de cuando la operación se detiene debido al error exhibido al configurar SW2 como abajo. (SW2)	Exhibe el código

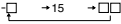

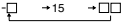

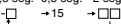

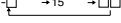

Configuración de SW2	Detalle del display	Explicación del display	Unidad
	Temperatura de cañería de líquido (TH3) cuando ocurre el error -40 a 90	-40 a 90 (Cuando el termistor de serpentina detecta 0° o inferior, se exhiben en forma alternada "°" y la temperatura) (Ejemplo) Cuando -15°C; 0,5 seg. 0,5 seg. 2seg. 	°C
	Temperatura del compresor (TH4) o temperatura de descarga (TH4) cuando ocurre el error 3 a 217	3-217 (Cuando la temperatura es 100° o superior, se exhiben en forma alternada las centenas, decenas y unidades) (Ejemplo) Cuando 130°C; 0,5 seg. 0,5 seg. 2seg. 	°C
	Corriente de operación del compresor cuando ocurre el error 0 a 20	0~20	A
	Historia del código de error (1) (última) Exhibe en forma alternada el número de la unidad anormal y el código	Cuando no hay historia de error, Se exhiben en forma alternada "0" y "-".	Exhibe el código
	Historia del código de error (2) Exhibe en forma alternada el número de la unidad anormal y el código	Cuando no hay historia de error, Se exhiben en forma alternada "0" y "-".	Exhibe el código
	Tiempo de termostato en ON 0~999	0-999 (Cuando son 100 minutos o mas, se exhiben en forma alternada las centenas, decenas y unidades) (Ejemplo) Cuando 245 minutos 0,5 seg. 0,5 seg. 2seg. 	Minuto
	Tiempo de ejecución del test run 0~120	0-120 (Cuando son 100 minutos o mas, se exhiben en forma alternada las centenas, decenas y unidades) (Ejemplo) Cuando 105 minutos 0,5 seg. 0,5 seg. 2seg. 	Minuto

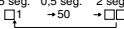
Configuración de SW2	Detalle del display	Explicación del display	Unidad																				
	Cantidad de unidades interiores conectadas	0-3 (Se exhibe la cantidad de unidades interiores conectadas)	Unidad																				
	Display de configuración de capacidad	Exhibido como un código de capacidad exterior. <table border="1" data-bbox="523 355 802 476"> <thead> <tr> <th>Capacidad</th> <th>Código</th> <th>Capacidad</th> <th>Código</th> </tr> </thead> <tbody> <tr> <td>RP35V</td> <td>9</td> <td>RP100V, 100Y</td> <td>20</td> </tr> <tr> <td>RP50V</td> <td>10</td> <td>RP125V, 125Y</td> <td>25</td> </tr> <tr> <td>RP60V</td> <td>11</td> <td>RP140V, 140Y</td> <td>28</td> </tr> <tr> <td>RP71V</td> <td>14</td> <td></td> <td></td> </tr> </tbody> </table>	Capacidad	Código	Capacidad	Código	RP35V	9	RP100V, 100Y	20	RP50V	10	RP125V, 125Y	25	RP60V	11	RP140V, 140Y	28	RP71V	14			Exhibe el código
Capacidad	Código	Capacidad	Código																				
RP35V	9	RP100V, 100Y	20																				
RP50V	10	RP125V, 125Y	25																				
RP60V	11	RP140V, 140Y	28																				
RP71V	14																						
	Información de configuración de unidad exterior	<ul style="list-style-type: none"> Las decenas (Exhibición total para configuración aplicada) <table border="1" data-bbox="492 506 859 589"> <thead> <tr> <th>Detalles de configuración</th> <th>Detalles del display</th> </tr> </thead> <tbody> <tr> <td>H•P / Sólo refrigeración</td> <td>0 : H•P 1 : Sólo refrigeración</td> </tr> <tr> <td>Monofásico / trifásico</td> <td>0 : Monofásico 2 : Trifásico</td> </tr> </tbody> </table> Las unidades <table border="1" data-bbox="492 619 859 672"> <thead> <tr> <th>Detalles de configuración</th> <th>Detalles del display</th> </tr> </thead> <tbody> <tr> <td>Interruptor de desescarchado</td> <td>0 : Normal 1 : Para alta humedad</td> </tr> </tbody> </table> <p>(Ejemplo) Cuando la bomba de calor, trifásica y desescarchado (normal) están configurados, se exhibe "20".</p>	Detalles de configuración	Detalles del display	H•P / Sólo refrigeración	0 : H•P 1 : Sólo refrigeración	Monofásico / trifásico	0 : Monofásico 2 : Trifásico	Detalles de configuración	Detalles del display	Interruptor de desescarchado	0 : Normal 1 : Para alta humedad	Exhibe el código										
Detalles de configuración	Detalles del display																						
H•P / Sólo refrigeración	0 : H•P 1 : Sólo refrigeración																						
Monofásico / trifásico	0 : Monofásico 2 : Trifásico																						
Detalles de configuración	Detalles del display																						
Interruptor de desescarchado	0 : Normal 1 : Para alta humedad																						
	Temperatura de cañería interior / Líquido (TH2(1)) Interior 1 -39 a 88	- 39~88 (Cuando la temperatura es 0°C o inferior, se exhiben en forma alterna "+,-" y la temperatura).	°C																				
	Temperatura de cañería interior / Condensador/Evaporador (TH5(1)) Interior 1 -39 a 88	- 39~88 (Cuando la temperatura es 0°C o inferior, se exhiben en forma alterna "+,-" y la temperatura).	°C																				
	Temperatura de cañería interior / Líquido (TH2(2)) Interior 2 -39 a 88	- 39~88 (Cuando la temperatura es 0°C o inferior, se exhiben en forma alterna "+,-" y la temperatura).	°C																				
	Temperatura de cañería interior / Condensador/Evaporador (TH5(2)) Interior 2 -39 a 88	- 39~88 (Cuando la temperatura es 0°C o inferior, se exhiben en forma alterna "+,-" y la temperatura).	°C																				
	Temperatura ambiente interior (TH1) 8~39	8~39	°C																				

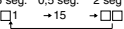
Configuración de SW2	Detalle del display	Explicación del display	Unidad
	Configuración de temperatura interior 17~30	17~30	°C
	Temperatura de cañería exterior (Condensador / Evaporador). (TH6) - 39~88	- 39~88 (Cuando la temperatura es 0°C o inferior, se exhiben en forma alterna "-" y la temperatura).	°C
	Temperatura externa exterior (TH7) - 39~88	- 39~88 (Cuando la temperatura es 0°C o inferior, se exhiben en forma alterna "-" y la temperatura).	°C
	Temperatura del disipador interno de la unidad exterior (TH8) - 40~200	- 40~200 (Cuando la temperatura es 0°C o inferior, se exhiben en forma alterna "-" y la temperatura). (Cuando el termistor detecta 100°C o superior, se exhiben en forma alternada las centenas, decenas y unidades).	°C
	Sobrecalentamiento de descarga. SHD 0~255 [Refrigeración = TH4-TH6] [Calefacción = TH4-TH5]	0~255 (Cuando la temperatura es 100°C o superior, se exhiben en forma alternada las centenas, decenas y unidades).	°C
	Sub refrigeración. SC 0~130 [Refrigeración = TH6-TH3] [Calefacción = TH5-TH4]	0~130 (Cuando la temperatura es 100°C o superior, se exhiben en forma alternada las centenas, decenas y unidades).	°C
	Corriente de entrada en la unidad exterior.	0~500 (Cuando la temperatura es 100°C o superior, se exhiben en forma alternada las centenas, decenas y unidades).	0,1 A
	Pulso de apertura de la VEL-B	0~480 (Cuando es 100 pulsos o superior, se exhiben en forma alternada las centenas, decenas y unidades).	Pulso
	Frecuencia de operación esperada 0~255	0~255 (Cuando es 100Hz o superior, se exhiben en forma alternada las centenas, decenas y unidades).	Hz
	Tensión de CC del bus 180-370	180-370 (Cuando es 100V o superior, se exhiben en forma alternada las centenas, decenas y unidades).	V

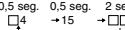
Configuración de SW2	Detalle del display	Explicación del display	Unidad
	<p>Ahorro de capacidad 0~100 Cuando el acondicionador de aire es conectado al M-NET y se demanda el modo de ahorro de capacidad, se exhibe "0"-~"100".</p> <p>[Cuando no hay configuración de ahorro de capacidad se exhibe "100".]</p>	<p>0~100 (Cuando la capacidad es 100%, se exhiben en forma alternada las centenas, decenas y unidades). (Ejemplo) Cuando 100%; 0,5 seg. 0,5 seg. 2 seg. </p>	%
	Historia de código de postergación (2) de la unidad exterior	<p>Postponement code display Blinking: During postponement Lighting: Cancellation of postponement 0000 is displayed in case of no postponement.</p>	Exhibe el código
	Historia de código de postergación (3) de la unidad exterior	<p>Display de código de postergación Parpadeando: Durante la postergación Encendido: Cancelación de la postergación "00" se exhibe en caso de no postergación</p>	Exhibe el código
	Historia de código de error (3) (más viejo) Se exhibe en forma alternada el número de unidad anormal y el código.	Cuando no hay historia de error, se exhiben en forma alternada "0" y "-".	Exhibe el código
	<p>Display de error de termistor</p> <p>[Cuando no hay error de termistor, se exhibe "-".]</p>	<p>3: Temperatura de cañería exterior / Líquido (TH3) 6: Temperatura de cañería exterior / Condensador/ evaporador (TH6) 7: Temperatura exterior de la unidad exterior (TH7) 8: Temperatura del disipador exterior (TH8)</p>	Exhibe el código
	Frecuencia de operación al ocurrir el error 0~255	<p>0~255 (Cuando es 100Hz o superior, se exhiben en forma alternada las centenas, decenas y unidades). (Ejemplo) Cuando 125Hz; 0,5 seg. 0,5 seg. 2 seg. </p>	Hz
	Paso del ventilador al ocurrir el error 0~10	0~10	Pasos

Configuración de SW2	Detalle del display	Explicación del display	Unidad
	Pulso de apertura de la VEL-A al ocurrir el error 0-480	0-480 (Cuando es 100 pulsos o más, se exhiben en forma alternas centenas, decenas y unidades). (Ejemplo) Cuando 130 pulsos; 0,5 seg. 0,5 seg. 2 seg. 	Pulsos
	Temperatura ambiente interior (TH1) al ocurrir el error 8-39	8-39	°C
	Temperatura de cañería de líquido interior (TH2) al ocurrir el error -39 a 88	- 39-88 (Cuando la temperatura es 0°C o inferior, se exhiben en forma alterna "-" y la temperatura). (Ejemplo) Cuando -15°C; 0,5 seg. 0,5 seg. 2 seg. 	°C
	Temperatura de cañería de condensador/evaporador interior (TH5) al ocurrir el error -39 a 88	- 39-88 (Cuando la temperatura es 0°C o inferior, se exhiben en forma alterna "-" y la temperatura). (Ejemplo) Cuando -15°C; 0,5 seg. 0,5 seg. 2 seg. 	°C
	Temperatura de cañería de condensador/evaporador exterior (TH6) al ocurrir el error -39 a 88	- 39-88 (Cuando la temperatura es 0°C o inferior, se exhiben en forma alterna "-" y la temperatura). (Ejemplo) Cuando -15°C; 0,5 seg. 0,5 seg. 2 seg. 	°C
	Temperatura ambiente exterior (TH7) al ocurrir el error -39 a 88	- 39-88 (Cuando la temperatura es 0°C o inferior, se exhiben en forma alterna "-" y la temperatura). (Ejemplo) Cuando -15°C; 0,5 seg. 0,5 seg. 2 seg. 	°C
	Temperatura del disipador exterior (TH8) al ocurrir el error -40-200	-40-200 (Cuando la temperatura es 0°C o inferior, se exhiben en forma alterna "-" y la temperatura). (Cuando la temperatura es 100°C o superior, se exhiben en forma alternas centenas, decenas y unidades).	°C

Configuración de SW2	Detalle del display	Explicación del display	Unidad																											
	<p>Sobrecalentamiento de descarga al ocurrir el error. SHd 0-255</p> <p>[Refrigeración = TH4-TH6] [Calefacción = TH4-TH5]</p>	<p>0-255 (Cuando la temperatura es 100°C o superior, se exhiben en forma alternada las centenas, decenas y unidades). (Ejemplo) Cuando 150°C; 0,5 seg. 0,5 seg. 2 seg </p>	°C																											
	<p>Sub refrigeración al ocurrir el error. SC 0-130</p> <p>[Refrigeración = TH6-TH3] [Calefacción = TH5-TH4]</p>	<p>0-130 (Cuando la temperatura es 100°C o superior, se exhiben en forma alternada las centenas, decenas y unidades). (Ejemplo) Cuando 115°C; 0,5 seg. 0,5 seg. 2 seg </p>	°C																											
	<p>Tiempo de encendido del termostato hasta la detención de error 0-999</p>	<p>0-999 (Cuando es 100 minutos o superior, se exhiben en forma alternada las centenas, decenas y unidades). (Ejemplo) Cuando 415 minutos; 0,5 seg. 0,5 seg. 2 seg </p>	Minuto																											
	<p>Temperatura de cañería interior / Líquido (TH2(3)) Interior 3 -39 a 88</p>	<p>- 39-88 (Cuando la temperatura es 0°C o inferior, se exhiben en forma alterna "-" y la temperatura).</p>	°C																											
	<p>Temperatura de cañería interior / Condensador/Evaporador (TH5(3)) Interior 3 -39 a 88</p>	<p>- 39-88 (Cuando la temperatura es 0°C o inferior, se exhiben en forma alterna "-" y la temperatura). Cuando no hay unidad interior, se exhibe "00".</p>	°C																											
	<p>Operación de reemplazo * Si se efectúa la operación de reemplazo al menos una vez, se exhibe *1". Si el tiempo de la operación de reemplazo es menor de 2 horas se exhibe *0".</p>	<p>1: Efectuada. 0: Todavía no.</p>	-																											
	<p>Estado de error U9 durante el periodo de postergación de error</p>	<table border="1"> <thead> <tr> <th>Descripción</th> <th>Punto de detección</th> <th>Display</th> </tr> </thead> <tbody> <tr> <td>Normal</td> <td>-</td> <td>00</td> </tr> <tr> <td>Error de sobretensión</td> <td>Placa de alimentación</td> <td>01</td> </tr> <tr> <td>Error de baja tensión</td> <td>Placa controladora</td> <td>02</td> </tr> <tr> <td>Error de sensor de corriente de entrada</td> <td>Placa controladora</td> <td>04</td> </tr> <tr> <td>Error de fase L1 abierta.</td> <td>Placa controladora</td> <td>04</td> </tr> <tr> <td>Señal de sincronismo de alimentación anor.al</td> <td>Placa de alimentación</td> <td>08</td> </tr> <tr> <td>Error de PFC (RP35-71VHA.) (Sobretensión/bajatenSIon/sobrecorriente)</td> <td>Placa de alimentación</td> <td>10</td> </tr> <tr> <td>Error de PFC/ACTM (RP35-140VHA.) (baja tensión)</td> <td>Verifique el cableado CNAF. Placa ACTM defectuosa</td> <td>20</td> </tr> </tbody> </table> <p>* Ejemplo de displays para errores múltiples: Sobretensión (01) + Baja tensión (02) = 03 Baja tensión (02) + Error de sincronismo de alimentación (08) = 0A Error de fase L1 abierta (04) + Error de PCF (10) = 14</p>	Descripción	Punto de detección	Display	Normal	-	00	Error de sobretensión	Placa de alimentación	01	Error de baja tensión	Placa controladora	02	Error de sensor de corriente de entrada	Placa controladora	04	Error de fase L1 abierta.	Placa controladora	04	Señal de sincronismo de alimentación anor.al	Placa de alimentación	08	Error de PFC (RP35-71VHA.) (Sobretensión/bajatenSIon/sobrecorriente)	Placa de alimentación	10	Error de PFC/ACTM (RP35-140VHA.) (baja tensión)	Verifique el cableado CNAF. Placa ACTM defectuosa	20	Exhibe el código
Descripción	Punto de detección	Display																												
Normal	-	00																												
Error de sobretensión	Placa de alimentación	01																												
Error de baja tensión	Placa controladora	02																												
Error de sensor de corriente de entrada	Placa controladora	04																												
Error de fase L1 abierta.	Placa controladora	04																												
Señal de sincronismo de alimentación anor.al	Placa de alimentación	08																												
Error de PFC (RP35-71VHA.) (Sobretensión/bajatenSIon/sobrecorriente)	Placa de alimentación	10																												
Error de PFC/ACTM (RP35-140VHA.) (baja tensión)	Verifique el cableado CNAF. Placa ACTM defectuosa	20																												

1. CONFIGURACIÓN DE FUNCIÓN DE UNIDAD MEDIANTE EL CONTROL REMOTO

Cada función puede ser configurada de acuerdo a la necesidad usando el control remoto. La configuración de función para cada unidad sólo puede ser efectuada mediante el control remoto. Seleccione la función disponible de la tabla 1.

<Tabla 1> Selección de función

(1) Funciones disponibles cuando se configura el número de unidad en 00 (Seleccione 00 refiriéndose a **4. Configurando el número de unidad**).

*1 Las funciones de abajo están disponibles sólo cuando se utiliza el control remoto cableado. Las funciones no están disponibles para los modelos verticales de piso.

Función	Configuración	Nº Modo	Config. Nº	Configuración inicial (al salir de fábrica)	Observaciones
Recuperación automática de falla de alimentación	OFF	01	1		La configuración es aplicada a todas las unidades en el mismo sistema refrigerante.
	ON		2	●	
Detección de temperatura interior	Unidades interiores operando (El promedio es considerado como temperatura interior). Unidad interior con control remoto Sensor interno del control remoto	02	1	●	
			2		
			3		
Conectividad LOSSNAY	No soportado Soportado (unidad interior no equipada con entrada de aire exterior) Soportado (unidad interior equipada con entrada de aire exterior)	03	1	●	
			2		
			3		
Tensión de alimentación	240V 220V 230V	04	1	●	
			2	●	
Modo de autooperación	Operación de ahorro automático de energía ON Operación de ahorro automático de energía OFF	05	1	●	
			2	●	
Temperatura de prevención de escarchado	2°C (Normal) 3°C	15	1	●	
			2	●	
Control de humidificador	Cuando el compresor opera, también opera el humidificador Cuando el ventilador opera, también opera el humidificador	16	1	●	
			2	●	
Cambio del control de desescarchado	Estandar Para alta humedad	17	1	●	
			2	●	

(2) Funciones disponibles cuando se configura el número de unidad en 01-03 o ALL (07 en caso de control remoto inalámbrico)

- Cuando se configuran las funciones para una unidad interior en un sistema independiente, configure el número a 01 refiriéndose a **4. Configurando el número de unidad**.
- Cuando configure funciones para un sistema simultáneo de unidades interiores Doble o Triple, configure el número de unidad en 01 a 03 para cada unidad en caso de seleccionar diferentes funciones para cada unidad refiriéndose a **4. Configurando el número de unidad**.
- Cuando configure las mismas funciones para todo el sistema simultáneo de unidades interiores Doble o Triple, configure la dirección de refrigerante en ALL (07 en caso de control remoto inalámbrico) refiriéndose a **4. Configurando el número de unidad**.

Función	Configuraciones	Nº de modo	Nº de configuración	Configuración inicial (Predeterminada de fábrica)					
				: No disponible					
				Cassete de 4 vías PLA-AA	Escondido de calefacción PEAD-EA PEAD-GA	Suspendido de calefacción PCA-GA	PCA-HA	Montado en pared PKA-GAL PKA-FAL	Unidad de piso PSA-GA
Señal de filtro	100Hr	07	1						
	2500Hr		2	●		●	●	●	
	No filter sign indicator		3		●				
Flujo de aire (Velocidad del ventilador)	Silencioso } Estándar } Calefacción alto 1 } PLA-AA	08	1	●	-	-	-	-	-
	Estándar } Calefacción alto 2 }		2	-	-	●	-	-	-
	Calefacción alto 1 } Calefacción alto 2 }		3	-	-	-	-	-	-
Cantidad de salidas de aire	4 direcciones	09	1	●	-	-	-	-	-
	3 direcciones		2	-	-	-	-	-	
	2 direcciones		3	-	-	-	-	-	
Filtro opcional de alta eficiencia	No soportado	10	1	●	-	●	-	-	-
	Soportado		2	-	-	-	-	-	
Configuración de aletas	Sin aletas (Configuración de aleta N°3: Sólo PLA-AA)	11	1	-	-	-	-	-	-
	Configuración de aleta N°1		2	-	-	●	-	-	-
	Configuración de aleta N°2		3	●	-	-	-	-	-
Flujo de aire de ahorro de energía (Modo calefacción)	Deshabilitado	12	1	●	-	●	-	-	-
	Habilitado		2	-	-	-	-	-	
Humidificador opcional (Sólo PLA-AA)	No soportado	13	1	●	-	-	-	-	-
	Soportado		2	-	-	-	-	-	
Configuración diferencial de aleta en modo calefacción (prevención de soplado frío)	Configuración N°1 (THS: 24-28°C)	14	1	-	-	-	-	-	-
	Configuración N°2 (Estándar THS: 28-32°C)		2	●	-	●	-	●	-
	Configuración N°3 (THS: 32-38°C)		3	-	-	-	-	-	-
Abanico	No disponible	23	1	-	-	-	-	-	-
	Disponible		2	●	-	●	-	●	-
Temperatura configurada en modo calefacción (4º arriba)	Disponible	24	1	●	●	●	●	●	●
	No disponible		2	-	-	-	-	-	-
Velocidad del ventilador cuando el termostato de calefacción está en OFF	Extra baja	25	1	●	●	●	●	●	●
	Detener		2	-	-	-	-	-	
	Configurar velocidad del ventilador		3	-	-	-	-	-	
Modo de operación silenciosa del PLA-AA (velocidad del ventilador)	Deshabilitado (Estándar)	26	1	●	-	-	-	-	-
	Habilitado (modo de operación silenciosa)		2	-	-	-	-	-	
Velocidad del ventilador cuando el termostato de refrigeración está en OFF	Configurar velocidad del ventilador	27	1	●	●	●	●	●	●
	Detener		2	-	-	-	-	-	
Detección de anomalía de temperatura de cañería (P8)	Disponible	28	1	●	●	●	●	●	●
	No disponible		2	-	-	-	-	-	

12-1-1. Seleccionando funciones usando el control remoto cableado

Primero, trate de familiarizarse con el flujo del procedimiento de selección de funciones. En esta sección, se da un ejemplo de configuración de posición de detección de temperatura.

Para las operaciones actuales, refiérase a los pasos 1 a 10.

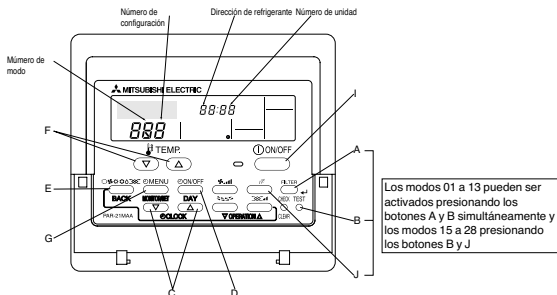

Seleccionando las funciones utilizando el control remoto cableado

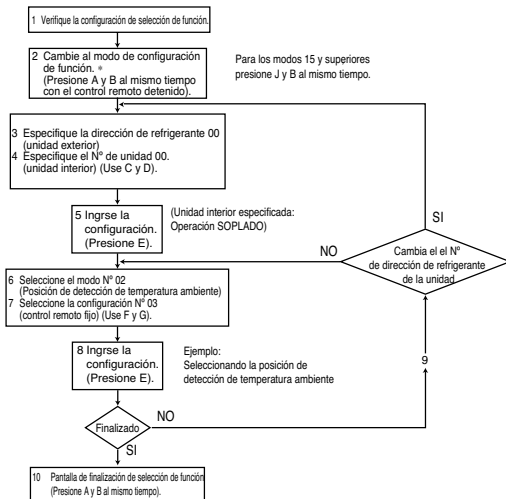

El procedimiento de arriba debe efectuarse sólo si son necesarios los cambios.

[Procedimiento de Operación]

1 Verifique los ítems de configuración provistos mediante la selección de función.

Si las configuraciones para un modo son cambiadas por selección de función, las funciones de ese modo serán cambiadas acordeamente. Verifique todas las configuraciones actuales de acuerdo a los pasos 2 a 7. Complete la columna "Revisado" en la Tabla 1, y entonces cámbielas según sea necesario. Para la configuración de fábrica, refiérase al manual de instalación de las unidades interiores.

2 Apague el control remoto.

A Mantenga presionados los botones **FILTER** y **TEST** en forma simultánea durante por lo menos dos segundos. Comenzará a parpadear **FUNCTION SELECTION** y entonces el contenido del display del control remoto y cambiará como se muestra abajo.

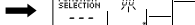
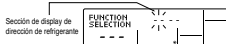

3 Configure la dirección de refrigerante de la unidad exterior.

C Presione los botones **CLOCK** (**∇**) y **△** para seleccionar la dirección de refrigerante deseada. La dirección de refrigerante cambia desde "00" a "15". (Esta operación no es posible para sistemas de refrigerante simple).

* Si la unidad se detiene después que **FUNCTION SELECTION** parpadea por 2 segundos o parpadea "88" en el área del display de temperatura ambiente por dos segundos, significa que ocurrió un error de transmisión. Verifique si hay alguna fuente de ruido o interferencia cercana al canal de transmisión.

Nota

Si cometió errores de operación durante este procedimiento, salga de la selección de función (vea el paso 10) y luego rearranque desde el paso 2.

4 Configure el número de unidad interior.

D Presione el botón **ON/OFF** de modo que parpadee "--" en el área de display de número de unidad.

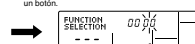

C Presione los botones **CLOCK** (**∇**) y **△** para seleccionar el número de la unidad interior para la cual desea efectuar la selección de función. El número de unidad cambia a "00", "01", "02", "03", "04" y "AL" cada vez que se presiona un botón.

* Para configurar los modos 01 a 06 o 15 a 22 seleccione el número de unidad "00".

* Para configurar los modos 07 a 14 o 23 a 28 efectúe lo siguiente:

- Para configurar cada unidad interior individualmente, selecciónese "01" a "04".
- Para configurar todas las unidades interiores colectivamente, selecciónese "AL".

5 Confirme la dirección de refrigerante y número de unidad.

E Presione el botón **MODE** para confirmar la dirección de refrigerante y el número de unidad.

Después de un rato, comenzará a parpadear "--" en el área de display de número de modo.



* Parpadeará "88" en el área de display de temperatura ambiente si la dirección de refrigerante seleccionada no existe en el sistema.

Más aún, si aparece "F" y parpadea en el área de display de número de unidad y también parpadea el área de display de dirección de refrigerante, no hay unidades que correspondan con el número de unidad seleccionado. En este caso, la dirección de refrigerante y el número de unidad pueden estar incorrectos, de modo que repita los pasos 2 y 3 para configurar los correctos.

E Cuando la dirección de refrigerante y el número de unidad son confirmados presionando el botón **MODE**, la unidad interior correspondiente comenzará la operación del ventilador. Esto le ayudará a encontrar la ubicación de la unidad interior para la cual desea efectuar la selección de función. Sin embargo, si se selecciona "00" o "AL" como número de unidad, todas las unidades interiores correspondientes a la dirección de refrigerante especificada comenzarán la operación del ventilador.

Ejemplo: Cuando la dirección de refrigerante se configura en 00 y el número de unidad es 02

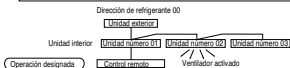

* Cuando se agrupan diferentes sistemas de refrigerante, si una unidad interior diferente de aquella a la cual se ha configurado la dirección de refrigerante efectúa la operación del ventilador, significa que debe haber otra dirección de refrigerante que es la misma que la especificada. En este caso, verifique el interruptor DIP de la unidad exterior para ver dónde existe tal dirección de refrigerante.

6 Seleccione el número de modo.

F Presione los botones **TEMP** (**∇**) y **△** para configurar el número de modo deseado. (Sólo pueden seleccionarse los números de modo seleccionables).

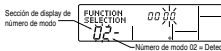

Número de modo 02 = Detección de temperatura interior.

7 Seleccione el contenido de configuración del modo seleccionado.

G Presione el botón **MENU**. El número de configuración actualmente seleccionado parpadeará, de modo que verifique el contenido configurado actual.

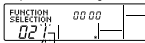

F Presione los botones **TEMP** (**∇**) y **△** para seleccionar en número de configuración deseado.

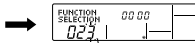

Sección de display de número de configuración. Número de configuración 1 = Promedio de operación de unidad interior. Número de configuración 3 = sensor incorporado en el control remoto.

8 Registre las configuraciones que efectuó en los pasos 3 a 7.

E Presione el botón **MODE**. En número de modo y el número de configuración comenzarán a parpadear y comienza la registración.

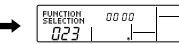
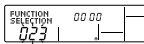

El número de modo y de configuración dejarán de parpadear y permanecerán encendidos indicando el fin de la registración.

* Si se exhibe "--" tanto para el número de modo y número de configuración y "88" parpadea en el área de display de temperatura ambiente, puede haber ocurrido un error de transmisión. Verifique si hay alguna fuente de ruido o interferencia cerca de la línea de transmisión.

9 Si desea continuar seleccionando otras funciones, repita los pasos 3 a 8.

10 Finalización de la selección de función.

A Mantenga presionados los botones **FILTER** y **TEST** en forma simultánea durante por lo menos dos segundos. Después de un instante, la pantalla de selección de función desaparecerá y reaparecerá la pantalla OFF del acondicionador de aire.

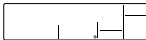

* No opere el control remoto por lo menos durante 30 segundos después de completar la selección de función. (no se aceptarán operaciones aun si se efectúan).

Nota

Si una función de una unidad interior se cambia mediante la selección de función después que se finalizó la instalación, asegúrese de que una marca "O", etc., esté en la columna "Revisar" de la Tabla 1 para indicar el cambio.

12-1-2. Seleccionando funciones usando el control remoto inalámbrico (Tipo C)

Las funciones pueden ser seleccionadas con el control remoto inalámbrico. La selección de funciones usando el control remoto inalámbrico está disponible sólo para los sistemas refrigerantes con función inalámbrica. Las direcciones refrigerante no pueden ser especificadas mediante el control remoto inalámbrico.

[Flujo del procedimiento de selección de función]



El flujo del procedimiento de selección de función se muestra abajo. Este ejemplo muestra cómo apagar la función que aumenta la temperatura configurada en 4 grados durante la operación de Calefacción. El procedimiento se da después del diagrama de flujo.

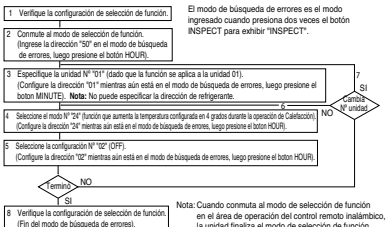

[Instrucciones de operación]

- Verifique las configuraciones de función.
- Presione dos veces seguidas el botón . → Se encenderá y parpadeará "00". Presione una vez el botón para configurar "50". Dirija el control remoto inalámbrico hacia el receptor en la unidad interior y presione el botón .
- Configure el número de unidad. Presione los botones para configurar el número de unidad. (Presione "01" para especificar la unidad interior cuyo número de unidad es 01). Dirija el control remoto inalámbrico hacia el receptor de la unidad interior y presione el botón . (Al configurar el número de unidad con el botón , la unidad interior especificada comenzará a operar el ventilador. Detecte qué unidad está asignada a cada número usando esta función. Si el número es configurado como "AL" todas las unidades interiores dentro del mismo sistema refrigerante comenzarán a efectuar la operación del ventilador simultáneamente.
 - Si un número de unidad no puede ser reconocido por la unidad que es ingresado, se escucharán 3 beeps de 0,4 segundos. Reingrese la configuración del número de unidad.
 - Si la señal no fué recibida por el sensor, no escuchará un beep o escuchará un doble beep. Reingrese la configuración del número de unidad.
- Selección de modo. Presione los botones para configurar un modo. Presione "24" para encender la función que eleva la temperatura configurada en 4 grados durante la operación de calefacción. Dirija el control remoto inalámbrico hacia el sensor de la unidad interior y presione el botón . → El indicador de operación de sensor parpadeará y se escucharán beeps para indicar el número de configuración actual. Número de configuración actual: 1 = 1 beep (un segundo)
2 = 2 beeps (un segundo cada uno)
3 = 3 beeps (un segundo cada uno)
 - Si un número de modo que no puede ser reconocido por la unidad es ingresado, se escucharán 3 beeps de 0,4 segundos. Reingrese el número de modo.
 - Si la señal no fué recibida por el sensor, no escuchará un beep o podrá escuchar un doble beep. Reingrese el número de modo.
- Selección de número de configuración. Presione los botones para configurar un modo. (02: No disponible) Dirija el control remoto inalámbrico hacia el sensor de la unidad interior y presione el botón . → El indicador de operación de sensor parpadeará y se escucharán beeps para indicar el número de configuración actual. Número de configuración actual: 1 = 1 beep (un segundo)
2 = 2 beeps (un segundo cada uno)
3 = 3 beeps (un segundo cada uno)
 - Si un número de modo que no puede ser reconocido por la unidad es ingresado, la configuración volverá a la configuración original.
 - Si la señal no fué recibida por el sensor, no escuchará un beep o podrá escuchar un doble beep. Reingrese la configuración
- Repita los pasos 4 y 5 para efectuar una configuración adicional sin cambiar el número de unidad.
- Repita los pasos 3 a 5 para cambiar el número de unidad y efectuar la configuración de función en él.
- Complete la configuración de función. Presione el botón .
 - No utilice el control remoto inalámbrico por 30 segundos después de completar la configuración de función.

2. SELECCIÓN DE FUNCIÓN EN EL CONTROL REMOTO

La configuración de las siguientes funciones del control remoto pueden ser cambiadas usando el modo de selección de función de control remoto. Cambie la configuración cuando lo necesite.

Item 1	Item 2	Item 3 (Contenido de configuración)
1. Cambio de idioma ("CHANGE LANGUAGE")	Display de configuración de idioma	• Es posible el display en múltiples idiomas.
2. Límite de función ("FUNCTION SELECTION")	1) Configuración de límite de operación de función ("LOCKING FUNCTION") 2) Uso de configuración de modo automático ("SELECT AUTO MODE") 3) Configuración de límite de rango de temperatura ("LIMIT TEMP FUNCTION")	• Configurando el límite del rango de operación (operación bloqueada) • Configurando el uso o no uso del modo de operación "automático" • Configurando el rango de temperatura ajustable (máximo, mínimo)
3. Selección de modo ("MODE SELECTION")	1) Configuración de modo de control remoto principal/sub ("CONTROLLER MAIN/SUB") 2) Configuración de uso de reloj ("CLOCK") 3) Configuración de función de temporizador ("WEEKLY TIMER") 4) Configuración de número de contacto para situación de error ("CALL")	• Seleccionando el control remoto principal/sub • Cuando dos controles remotos están conectados a un grupo, uno de los controles debe configurarse como sub. • Configurando el uso o no de la función reloj • Configurando el tipo de temporizador • Display de número de contacto en caso de error • Configuración de número de teléfono.
4. Cambio de display ("DISP MODE SETTING")	1) Configuración de display de temperatura: "C/F" ("TEMP MODE: C/F") 2) Configuración de display de temperatura de succión de aire ("ROOM TEMP DISP SELECT") 3) Configuración de display de refrigeración/cafeación automática ("AUTO MODE DISP CH")	• Configuración de la unidad de temperatura a exhibir "C/F" • Configurando el uso o no uso del display de temperatura de succión de aire interior • Configurando el uso o no uso del display de refrigeración / calefacción durante la operación con modo automático

[Diagrama de flujo de selección de función] Refiérase a la próxima página.

[1] Detenga el acondicionador de aire para iniciar el modo de selección de función del control remoto → [2] Seleccione desde item1. → [3] Seleccione desde item2. → [4] Efectúe la configuración. (Los detalles están especificados en el item3) → [5] Finalización de la configuración. → [6] Cambie el display al normal. (Fin).

[Configuración detallada]

[4]-1. Configuración de CAMBIO DE IDIOMA

El idioma que aparece en el display de puntos puede ser seleccionado.

- Presione el botón [MENU] para cambiar el idioma.
 - 1 Japonés (JP), 2 Inglés (GB), 3 Alemán (D), 4 Español (E), 5 Ruso (RU), 6 Italiano (I), 7 Chino (CH), 8 Francés (F)

[4]-2. Límite de función

(1) Configuración del límite de operación de función (bloqueo de operación)

- Para conmutar la operación, presione el botón [ON/OFF].
- 1 no1: La configuración de bloqueo de operación se efectúa en todos los botones que no sean el botón [ON/OFF].
- 2 no2: La configuración de bloqueo de operación se efectúa en todos los botones.
- 3 OFF (Valor de configuración inicial): La configuración de bloqueo de operación no se efectúa.

• Para validar la configuración de bloqueo de operación en la pantalla normal, es necesario presionar botones (Mantenga presionados los botones [FILTER] y [ON/OFF] al mismo tiempo por dos segundos) en la pantalla normal después de efectuar la configuración de arriba.

(2) Uso de la configuración de modo automático

Cuando se conecta el control remoto a la unidad que tiene el modo de operación automático, se pueden efectuar las siguientes configuraciones.

- Para conmutar la operación, presione el botón [ON/OFF].
- 1 ON (Valor de configuración inicial): Se exhibe el modo automático cuando se selecciona el modo de operación.
- 2 OFF: No se exhibe el modo automático cuando se selecciona el modo de operación.

(3) Configuración del límite de rango de temperatura

Después de efectuar la configuración, se puede cambiar la temperatura dentro del rango establecido.

- Para conmutar la configuración, presione el botón [ON/OFF].
- 1 LIMIT TEMP COOL MODE: El rango de temperatura se puede cambiar en el modo refrigeración/secado.
- 2 LIMIT TEMP HEAT MODE: El rango de temperatura se puede cambiar en el modo calefacción.
- 3 LIMIT TEMP AUTO MODE: El rango de temperatura se puede cambiar en el modo automático.
- 4 OFF (configuración inicial): El límite del rango de temperatura no está activo.
- Cuando la configuración que no sea OFF es efectuada, la configuración del límite del rango de temperatura en el modo refrigeración, calefacción y automático se efectúa al mismo tiempo. Sin embargo, el rango no puede ser limitado cuando el rango de temperatura configurado no ha sido cambiado.
- Para aumentar o disminuir la temperatura, presione los botones [TEMP (▽) (Δ)].
- Para cambiar la configuración del límite superior y del límite inferior, presione el botón [*,#]. La configuración seleccionada parpadeará y la temperatura puede configurarse.
- Rango configurable
 Modo refrigeración/secado: Límite inferior: 19°C - 30°C Límite superior 30°C - 19°C
 Modo calefacción: Límite inferior: 17°C - 28°C Límite superior 28°C - 17°C
 Modo automático: Límite inferior: 19°C - 28°C Límite superior 28°C - 19°C

[4]-3. Configuración de selección de modo

- (1) Configuración de control remoto principal/sub
 - Para conmutar la configuración, presione el botón [ON/OFF].
 - 1 Principal: El control será el principal.
 - 2 Sub: El control será el sub.
 - (2) Uso de la configuración de reloj
 - Para conmutar la configuración, presione el botón [ON/OFF].
 - 1 ON: Se puede usar la función reloj.
 - 2 OFF: La función reloj no puede ser usada.
 - (3) Configuración de la función temporizador
 - Para conmutar la configuración, presione el botón [ON/OFF] (Seleccione uno de los siguientes).
 - 1 WEEKLY TIMER (configuración inicial en MA deluxe): Se puede usar el temporizador semanal.
 - 2 AUTO OFF TIMER: Se puede usar el temporizador de apagado automático.
 - 3 SIMPLE TIMER (Configuración predeterminada en MA suave): Se puede usar el temporizador simple.
 - 4 TIMER MODE OFF: El modo temporizador no puede ser usado.
 - Cuando la configuración de uso de reloj está en OFF, no se puede usar el temporizador semanal.
 - (4) Configuración de número de contacto para situación de error
 - Para conmutar la configuración, presione el botón [ON/OFF].
 - 1 CALL OFF: Los números de contacto configurados no se exhiben en caso de error.
 - 2 CALL **** * : Los números de contacto configurados se exhiben en caso de error.
 - 3 CALL : El número de contacto puede configurarse cuando el display es como mostrado a la izquierda.
 - Configurando números de contacto.
- Para configurar los números de contacto, siga estos procedimientos.
- Nueva el cursor parpadeante para configurar los números. Presione los botones [TEMP (▽) (Δ)] para mover el cursor a la derecha (izquierda). Presione los botones [CLOCK (▽) (Δ)] para configurar los números.
- #### [4]-4. Configuración de cambio de display
- (1) Configuración de display de temperatura
 - Para conmutar la configuración, presione el botón [ON/OFF].
 - 1 °C: Se utiliza la unidad de temperatura °C.
 - 2 °F: Se utiliza la unidad de temperatura °F.
 - (2) Configuración de display de temperatura de succión de aire.
 - Para conmutar la configuración, presione el botón [ON/OFF].
 - 1 ON: Se exhibe la temperatura de succión de aire.
 - 2 OFF: No se exhibe la temperatura de succión de aire.
 - (3) Configuración de display de refrigeración/cafeación automática
 - Para conmutar la configuración, presione el botón [ON/OFF].
 - 1 ON: Se exhibe "Automatic cooling" o "Automatic heating" si está corriendo el modo automático.
 - 2 OFF: Sólo se exhibe "Automatic" si está corriendo el modo automático.

1. CÓMO "MONITOREAR LA INFORMACIÓN DE OPERACIÓN"

- Encienda el [Monitoreo de información de operación]

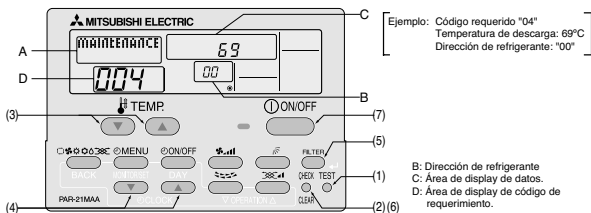

- (1) Presione el botón **TEST** durante tres segundos de modo que aparezca en la pantalla [Maintenance monitor] (en A).
- (2) Presione el botón **CHECK** durante tres segundos para pasar a [Monitor de mantenimiento].

Nota: Si no es posible pasar a [Monitor de mantenimiento] durante el requerimiento de datos en el modo mantenimiento (ej. mientras parpadea "----"), dado que ningún botón es operativo.

- Operando el monitor de inspección de servicio
Aparece en la pantalla (en D) cuando [Monitor de mantenimiento] está activado.
(El display (en D) ahora nos permite configurar un N° de código)

- (3) Presione los botones [TEMP] (**▼** y **▲**) para configurar la dirección de refrigerante deseada

[Pantalla B] → **00** ↔ **01** ↔ ↔ **15** ←

- (4) Presione los botones [CLOCK] (**▼** y **▲**) para configurar el N° de código de requerimiento deseado.
- (5) Presione el botón **FILTER** para efectuar el requerimiento de datos.
(La información requerida aparecerá en C del mismo modo que era en el modo de mantenimiento.)

La información recopilada durante la operación del control remoto será exhibida.

La información recopilada tal como la información de temperatura no será actualizada automáticamente aún si la información cambia.

Para exhibir la información actualizada, efectúe nuevamente el paso (4).

- Cancelando el Monitoreo de la información de operación.
- (6) Mientras se exhibe [Maintenance monitor], presione el botón **CHECK** por tres segundos y regrese al modo de mantenimiento.
 - (7) Para regresar al modo normal, presione el botón **ON/OFF**.

13-2. LISTA DE CÓDIGOS DE REQUERIMIENTO

* Ciertas combinaciones de unidades interior/exterior no tienen la función de código de requerimiento, por lo que no se exhiben los códigos de requerimiento.

Código de requerimiento	Contenido requerido	Descripción (Rango de display)	Unidad	Observaciones
0	Estado de operación	Referencia a 13-1: Contenidos Detallados del Código de Requerimiento.	-	
1	Compresor-Corriente de operación (rms)	0 - 50	A	
2	Compresor-Tiempo de operación acumulado	0 - 9999	10 horas	
3	Compresor-Cantidad de veces de operación	0 - 9999	100 veces	
4	Temperatura de descarga (TH4)	3 - 217	°C	
5	Unidad exterior - Temperatura de cañería de líquido (TH3)	-40 - 90	°C	
6	Unidad exterior - Temperatura de cañería de líquido 2	-40 - 90	°C	
7	Unidad exterior - Temperatura de cañería de 2 fases (TH6)	-39 - 88	°C	
8				
9	Unidad exterior - Temperatura de aire exterior (TH7)	-39 - 88	°C	
10	Unidad exterior - Temperatura de disipador (TH8)	-40 - 200	°C	
11				
12	Sobrecalentamiento de descarga (SHd)	0 - 255	°C	
13	Sub frío (SC)	0 - 130	°C	
14				
15				
16	Compresor-Frecuencia de operación	0 - 255	Hz	
17	Compresor-Frecuencia de operación destino	0 - 255	Hz	
18	Unidad exterior-Paso de salida del ventilador	0 - 10	Paso	
19	Unidad exterior-Velocidad del ventilador 1 (Sólo para acondicionadores de aire con motor de ventilador de CC)	0 - 9999	rpm	
20	Unidad exterior-Velocidad del ventilador 2 (Sólo para acondicionadores de aire con motor de ventilador de CC)	0 - 9999	rpm	Se exhibe "0" si el acondicionador de aire es del tipo de ventilador simple.
21				
22	Apertura de la VEL (A)	0 - 500	Pulsos	
23	Apertura de la VEL (B)	0 - 500	Pulsos	
24				
25	Corriente primaria	0 - 50	A	
26	Tensión de CC del bus	180 - 370	V	
27				
28				
29	Cantidad de unidades interiores conectadas	0 - 4	Unidades	
30	Unidad interior-Temperatura configurada	17 - 30	°C	
31	Unidad interior-Temperatura de aire de entrada-<Medida por el termostato>	8 - 39	°C	
32	Unidad interior-Temperatura de aire de entrada (Unidad N° 1) <Modo calefacción-corrección de 4 grados>	8 - 39	°C	Se exhibe "0" si la unidad de destino no está presente.
33	Unidad interior-Temperatura de aire de entrada (Unidad N° 2) <Modo calefacción-corrección de 4 grados>	8 - 39	°C	↑
34	Unidad interior-Temperatura de aire de entrada (Unidad N° 3) <Modo calefacción-corrección de 4 grados>	8 - 39	°C	↑
35	Unidad interior-Temperatura de aire de entrada (Unidad N° 4) <Modo calefacción-corrección de 4 grados>	8 - 39	°C	↑
36				
37	Unidad interior-Temperatura de cañería de líquido (Unidad N° 1)	-39 - 88	°C	Se exhibe "0" si la unidad de destino no está presente.
38	Unidad interior-Temperatura de cañería de líquido (Unidad N° 2)	-39 - 88	°C	↑
39	Unidad interior-Temperatura de cañería de líquido (Unidad N° 3)	-39 - 88	°C	↑
40	Unidad interior-Temperatura de cañería de líquido (Unidad N° 4)	-39 - 88	°C	↑
41				
42	Unidad interior-Temperatura de cañería de Cond./Eva. (Unidad N° 1)	-39 - 88	°C	Se exhibe "0" si la unidad de destino no está presente.
43	Unidad interior-Temperatura de cañería de Cond./Eva. (Unidad N° 2)	-39 - 88	°C	↑
44	Unidad interior-Temperatura de cañería de Cond./Eva. (Unidad N° 3)	-39 - 88	°C	↑
45	Unidad interior-Temperatura de cañería de Cond./Eva. (Unidad N° 4)	-39 - 88	°C	↑
46				
47				
48	Tiempo de operación de termostato ON	0 - 999	Minutos	
49	Tiempo transcurrido de test run	0 - 120	Minutos	← No es posible activar el modo de mantenimiento durante el test run.

Código de requerimiento	Contenido requerido	Descripción (Rango de display)	Unidad	Observaciones
50	Unidad interior-Estado de control	Referencias 13-2-1. Contenidos detallados del código de requerimiento.	-	
51	Unidad exterior-Estado de control	Referencias 13-2-1. Contenidos detallados del código de requerimiento.	-	
52	Compresor-Estado de control de frecuencia	Referencias 13-2-1. Contenidos detallados del código de requerimiento.	-	
53	Unidad exterior-Estado de control del ventilador	Referencias 13-2-1. Contenidos detallados del código de requerimiento.	-	
54	Estado de salida del actuador		-	
55	Contenido de error (U9)		-	
56				
57				
58				
59				
60	Capacidad de demanda de señal de transmisión	0 - 255	%	
61	Capacidad de demanda de contacto	Referencias 13-2-1. Contenidos detallados del código de requerimiento.	-	
62	Estado de entrada externa(modos silencioso, etc)	Referencias 13-2-1. Contenidos detallados del código de requerimiento.	-	
63				
64				
65				
66				
67				
68				
69				
70	Unidad exterior-Capacity setting display	Referencias 13-2-1. Contenidos detallados del código de requerimiento.	-	
71	Unidad exterior-Información de configuración	Referencias 13-2-1. Contenidos detallados del código de requerimiento.	-	
72				
73	Unidad exterior-Información de configuración de SW1	Referencias 13-2-1. Contenidos detallados del código de requerimiento.	-	
74	Unidad exterior-Información de configuración de SW2	Referencias 13-2-1. Contenidos detallados del código de requerimiento.	-	
75				
76	Unidad exterior-Información de configuración de SW4	Referencias 13-2-1. Contenidos detallados del código de requerimiento.	-	
77	Unidad exterior-Información de configuración de SW5	Referencias 13-2-1. Contenidos detallados del código de requerimiento.	-	
78	Unidad exterior-Información de configuración de SW6	Referencias 13-2-1. Contenidos detallados del código de requerimiento.	-	
79	Unidad exterior-Información de configuración de SW7	Referencias 13-2-1. Contenidos detallados del código de requerimiento.	-	
80	Unidad exterior-Información de configuración de SW8	Referencias 13-2-1. Contenidos detallados del código de requerimiento.	-	
81	Unidad exterior-Información de configuración de SW9	Referencias 13-2-1. Contenidos detallados del código de requerimiento.	-	
82	Unidad exterior-Información de configuración de SW10	Referencias 13-2-1. Contenidos detallados del código de requerimiento.	-	
83				
84	Conexión de adaptador M-NET (presencia/ausencia)	"0000": No conectado "0001": Conectado	-	
85				
86				
87				
88				
89	Display de ejecución de operación de reemplazo/lavado	"0000": No lavado "0001": Lavado	-	
90	Unidad exterior-Información de versión de microcomputadora	Ejemplos: Ver 5.01 → "0501"	Versión	
91	Unidad exterior-Información de versión de microcomputadora (sub N°)	Información auxiliar (exhibida después de la información de versión) Ejemplos: Ver 5.01 A000 → "A000"	-	
92				
93				
94				
95				
96				
97				
98				
99				
100	Unidad exterior - Historia de postergación de error 1 (último)	Exhibe el código de postergación. ("-" se exhibe cuando no hay código de postergación)	Código	
101	Unidad exterior - Historia de postergación de error 2 (penúltimo)	Exhibe el código de postergación. ("-" se exhibe cuando no hay código de postergación)	Código	
102	Unidad exterior - Historia de postergación de error 3 (antepenúltimo)	Exhibe el código de postergación. ("-" se exhibe cuando no hay código de postergación)	Código	

Código de requerimiento	Contenido requerido	Descripción (Rango de display)	Unidad	Observaciones
103	Historia de error 1 (último)	Exhibe el código de postergación. ("-" se exhibe cuando no hay historia)	Código	
104	Historia de error 2 (penúltimo)	Exhibe el código de postergación. ("-" se exhibe cuando no hay historia)	Código	
105	Historia de error 3 (antepenúltimo)	Exhibe el código de postergación. ("-" se exhibe cuando no hay historia)	Código	
106	Display de termostor anormal (TH3/TH6/TH7/TH8)	3 °C TH3 6 °C TH6 7 °C TH7 8 °C TH8 0 °C Sin error de termostor	Número de sensor	
107	Modo de operación en el momento del error	Exhibido del mismo modo que el código de requerimiento "0"	-	
108	Compresor-Corriente de operación en el momento del error	0 - 50	A	
109	Compresor-Tiempo de operación acumulado en el momento del error	0 - 9999	10 horas	
110	Compresor-Cantidad de veces de operación en el momento del error	0 - 9999	100 veces	
111	Temperatura de descarga en el momento del error	3 - 217	°C	
112	Unidad exterior - Temperatura de cañería 1 (TH3) en el momento del error	-40 - 90	°C	
113	Unidad exterior - Temperatura de cañería 2 en el momento del error	-40 - 90	°C	
114	Unidad exterior - Temperatura de cañería de 2 fases (TH6) en el momento del error	-39 - 88	°C	
115				
116	Unidad exterior-Temperatura de aire exterior (TH7) en el momento del error	-39 - 88	°C	
117	Unidad exterior-Temperatura del dissipador (TH8) en el momento del error	-40 - 200	°C	
118	Sobrecalentamiento de descarga (SH4) en el momento del error	0 - 255	°C	
119	Subrefrigeración (SC) en el momento del error	0 - 130	°C	
120	Compresor-Frecuencia de operación en el momento del error	0 - 255	Hz	
121	Unidad exterior en el momento del error • Paso de salida de ventilador	0 - 10	Paso	
122	Unidad exterior en el momento del error • Velocidad del ventilador 1 (Solo para acondicionadores de aire con ventilador de CC)	0 - 9999	rpm	
123	Unidad exterior en el momento del error • Velocidad del ventilador 2 (Solo para acondicionadores de aire con ventilador de CC)	0 - 9999	rpm	Se exhibe "0" si el acondicionador de aire es del tipo de ventilador simple.
124				
125	Apertura de la VEL (A) en el momento del error	0 - 500	Pulsos	
126	Apertura de la VEL (B) en el momento del error	0 - 500	Pulsos	
127				
128				
129				
130	Tiempo de termostato ON hasta la detención de la operación debido a un error	0 - 999	Minutos	
131				
132	Interior - Temperatura de cañería de líquido en el momento del error	-39 - 88	°C	Se exhibe el valor promedio de todas las unidades interiores si el acondicionador de aire tiene dos o más unidades interiores (doble, triple, cuádruple)
133	Interior - Temperatura de cañería de 2 fases en el momento del error	-39 - 88	°C	Se exhibe el valor promedio de todas las unidades interiores si el acondicionador de aire tiene dos o más unidades interiores (doble, triple, cuádruple)
134	Interior en el momento del error • Temperatura de entrada de aire-Determinación de temperatura del termostato	-39 - 88	°C	
135				
136				
137				
138				
139				
140				
141				
142				
143				
144				
145				
146				
147				
148				
149				
150	Interior-Temperatura de entrada de aire actual	-39 - 88	°C	
151	Interior-Temperatura de cañería de líquido	-39 - 88	°C	
152	Interior-Temperatura de cañería de 2 fases	-39 - 88	°C	

Código de requerimiento	Contenido requerido	Descripción (Rango de display)	Unidad	Observaciones
153				
154	Interior-Tiempo de operación del ventilador (Después del reset del filtro)	0 - 9999	1 hora	
155	Interior-Tiempo de operación total (Tiempo de encendido del motor del ventilador)	0 - 9999	10 horas	
156				
157	Valor de salida del ventilador interior (valor S)	0 - 255 Información de control del ventilador	-	Para control de fase del ventilador interior
158	Valor de salida del ventilador interior (Pulsación ON/OFF)	"00 *** ****"Indica la información de control del ventilador	-	Para control de propulsión del ventilador interior
159	Valor de salida del ventilador interior (valor de ciclo)	"00 *** ****"Indica la información de control del ventilador	-	Para control del motor de CC sin escobillas
160				
161				
162	Unidad interior-Información de configuración de modelo	Reférase a 13-2-1 Contenidos detallados del código de requerimiento.	-	
163	Unidad interior-Información de configuración de capacidad	Reférase a 13-2-1 Contenidos detallados del código de requerimiento.	-	
164	Unidad interior-Información de SW3	Indefinido	-	
165	Configuración de Nº de par inalámbrico (del lado de la placa controladora interior)	Reférase a 13-2-1 Contenidos detallados del código de requerimiento.	-	
166	Unidad interior-Información de SW5	Indefinido	-	
167				
~				
189				
190	Unidad interior-Información de versión de microcomputador	Ejemplos Ver 5.01 → "0501"	Versión	
191	Unidad interior-Información de versión de microcomputador (sub Nº)	Información auxiliar (prohibida después de la información de versión) Ejemplos Ver 5.01 A000 → "A000"	-	
192				
~				
764				
765	Operación estable (Modo calefacción)	Este código de requerimiento no es previsto para recopilación de información. Se usa para reparar el estado de operación.		
766	Operación estable (Modo refrigeración)	Este código de requerimiento no es previsto para recopilación de información. Se usa para reparar el estado de operación.		
767	Cancelación de operación estable	Este código de requerimiento no es previsto para recopilación de información. Se usa para cancelar el estado de operación que ha sido reparado por los códigos de requerimiento "765" y "766".		

2-1. Contenidos Detallados en Código de Requerimiento

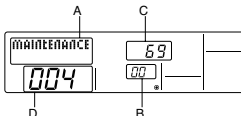

Ejemplo: Código requerido "004"
 Temperatura de descarga: 69°C
 Dirección de refrigerante "00"

B: Dirección de refrigerante
 C: Área de display de datos
 D: Área de display de código requerido

[Estado de operación] (Código requerido "0")

Display de datos



Estado del relé de salida
 Modo de operación

Modo de operación

Display	Modo de operación
0	STOP•VENTILADOR
C	FRIÓ•SECADO
H	CALOR
d	Desecarchado

Estado del relé de salida

Display	Potencia actualmente provista al compresor	Compresor	Válvula de 4 vías	Válvula solenoide
0	-	-	-	-
1				ON
2			ON	
3			ON	ON
4		ON		
5		ON		ON
6		ON	ON	
7		ON	ON	ON
8	ON			
A	ON		ON	

[Unidad interior - Estado de control] (Código requerido : "50")

Display de datos



Estado de unidad N° 4
 Estado de unidad N° 3
 Estado de unidad N° 2
 Estado de unidad N° 1

Display	Estado
0	Normal
1	Preparando para la operación de calefacción.
2	-
3	-
4	Calefactor encendido.
5	Protección anti-escarchado encendida.
6	Protección de sobrecalentamiento encendida.
7	Requiriendo el apagado del compresor.
F	No hay unidades correspondientes.

[Unidad interior - Estado de control] (Código requerido : "51")

Display de datos	Estado
0 0 0 0	Normal
0 0 0 1	Preparando para la operación de calefacción.
0 0 0 2	Desecarchado.

[Compresor - Estado de control de frecuencia] (Código requerido : "52")

Display de datos



Estado de control de frecuencia 2
 Estado de control de frecuencia 1

Estado de control de frecuencia 1

Display	Control de límite actual
0	Sin límite actual
1	Control de límite de corriente de primario encendido.
2	Control de límite de corriente de secundario encendido.

Estado de control de frecuencia 2

Display	Prevención de sobrecalentamiento de temperatura de descarga	Prevención de sobrecalentamiento de temperatura de condensación	Control de protección Antiescarchado	Prevención de sobrecalentamiento de temperatura de disparador
0				
1	Controlado			
2		Controlado		
3	Controlado	Controlado		
4			Controlado	
5	Controlado		Controlado	
6		Controlado	Controlado	
7	Controlado	Controlado	Controlado	
8				Controlado
9	Controlado			Controlado
A		Controlado		Controlado
b	Controlado	Controlado		Controlado
C			Controlado	Controlado
d	Controlado		Controlado	Controlado
E		Controlado	Controlado	Controlado
F	Controlado	Controlado	Controlado	Controlado

[Estado de control del Ventilador] (Código requerido "53")

Display de datos 0 0 * *

Valor de corrección de paso de ventilador mediante control de prevención de sobrecalentamiento de temperatura del disipador
 Valor de corrección de paso de ventilador mediante control de prevención de sobrecalentamiento de temperatura de condensación de refrigeración

Display	Valor de corrección
- (menos)	- 1
0	0
1	+1
2	+2

[Estado de salida del Actuador] (Código requerido "54")

Display de datos 0 0 * *

Estado de salida del actuador 1
 Estado de salida del actuador 2

Estado de salida del actuador 1

Display	SV1	Válvula de 4 vías	Compresor	El compresor está precalentando
0				
1	ON			
2		ON		
3	ON	ON		
4			ON	
5	ON		ON	
6		ON	ON	
7	ON	ON	ON	
8				ON
9	ON			ON
A		ON		ON
b	ON	ON		ON
C			ON	ON
d	ON		ON	ON
E		ON	ON	ON
F	ON	ON	ON	ON

Estado de salida del actuador 2

Display	52C	SV2	SS
0			
1	ON		
2		ON	
3	ON	ON	
4			ON
5	ON		ON
6		ON	ON
7	ON	ON	ON

[Contenido de error (U9)] (Código requerido "55")

Display de datos 0 0 * *

Contenido de error 1
 Contenido de error 2

Contenido de error 2

● : Detectado

Display	Error de sobretensión	Error de baja tensión	Error de fase L1 abierta	Señal de error de sincronizado de alimentación
0				
1	●			
2		●		
3	●	●		
4			●	
5	●		●	
6		●	●	
7	●	●	●	
8				●
9	●			●
A		●		●
b	●	●		●
C			●	●
d	●		●	●
E		●	●	●
F	●	●	●	●

Contenido de error 2

● : Detectado

Display	Error de Fo converter	Error de PAM
0		
1	●	
2		●
3	●	●

[Capacidad de demanda de contacto] (Código requerido *61*)

Display de datos

0	0	0	*
---	---	---	---

 Contenido de configuración

Contenido de configuración

Display	Valor configurado	Configuración	
		SW7-1	SW7-2
0	0%		
1	50%	ON	
2	75%		ON
3	100%	ON	ON

[Estado de entrada externa] (Código requerido *62*)

Display de datos

0	0	0	*
---	---	---	---

 Estado de entrada

Estado de entrada

● : Entrada presente

Display	Entrada de demanda de contacto	Entrada de modo silencioso	Entrada de libre 1	Entrada de libre 2
0				
1	●			
2		●		
3	●	●		
4			●	
5	●		●	
6		●	●	
7	●	●	●	
8				●
9	●			●
A		●		●
b	●	●		●
C			●	●
d	●		●	●
E		●	●	●
F	●	●	●	●

[Unidad exterior - Display de configuración de capacidad] (Código requerido *70*)

Display de datos	Capacidad
9	35
10	50
11	60
14	71
20	100
25	125
28	140
40	200
50	250

[Unidad exterior - Información de configuración] (Código requerido *71*)

Display de datos

0	0	*	*
---	---	---	---

 Información de configuración 1
 Información de configuración 2

Información de configuración 1

Display	Modo desescachado
0	Estándar
1	Para alta humedad

Información de configuración 2

Display	Mono/Trifásico	Bomba de calor/ sólo refrigeración
0	Monofásico	Bomba de calor
1		Sólo refrigeración
2	Trifásico	Bomba de calor
3		Sólo refrigeración

[Display de configuración de interruptores de la unidad exterior (SW1 a SW10, excepto SW3)] (Códigos requeridos: 73 a 82)

0: Interruptor OFF 1: Interruptor ON

SW1, SW2, SW6, SW7						Display de datos
1	2	3	4	5	6	
0	0	0	0	0	0	00 00
1	0	0	0	0	0	00 01
0	1	0	0	0	0	00 02
1	1	0	0	0	0	00 03
0	0	1	0	0	0	00 04
1	0	1	0	0	0	00 05
0	1	1	0	0	0	00 06
1	1	1	0	0	0	00 07
0	0	0	1	0	0	00 08
1	0	0	1	0	0	00 09
0	1	0	1	0	0	00 0A
1	1	0	1	0	0	00 0b
0	0	1	1	0	0	00 0C
1	0	1	1	0	0	00 0d
0	1	1	1	0	0	00 0E
1	1	1	1	0	0	00 0F
0	0	0	0	1	0	00 10
1	0	0	0	1	0	00 11
0	1	0	0	1	0	00 12
1	1	0	0	1	0	00 13
0	0	1	0	1	0	00 14
1	0	1	0	1	0	00 15
0	1	1	0	1	0	00 16
1	1	1	0	1	0	00 17
0	0	0	1	1	0	00 18
1	0	0	1	1	0	00 19
0	1	0	1	1	0	00 1A
1	1	0	1	1	0	00 1B
0	0	1	1	1	0	00 1C
1	0	1	1	1	0	00 1D
0	1	1	1	1	0	00 1E
1	1	1	1	1	0	00 1F
0	0	0	0	0	1	00 20
1	0	0	0	0	1	00 21
0	1	0	0	0	1	00 22
1	1	0	0	0	1	00 23
0	0	1	0	0	1	00 24
1	0	1	0	0	1	00 25
0	1	1	0	0	1	00 26
1	1	1	0	0	1	00 27
0	0	0	1	0	1	00 28
1	0	0	1	0	1	00 29
0	1	0	1	0	1	00 2A
1	1	0	1	0	1	00 2B
0	0	1	1	0	1	00 2C
1	0	1	1	0	1	00 2D
0	1	1	1	0	1	00 2E
1	1	1	1	0	1	00 2F
0	0	0	0	1	1	00 30
1	0	0	0	1	1	00 31
0	1	0	0	1	1	00 32
1	1	0	0	1	1	00 33
0	0	1	0	1	1	00 34
1	0	1	0	1	1	00 35
0	1	1	0	1	1	00 36
1	1	1	0	1	1	00 37
0	0	0	1	1	1	00 38
1	0	0	1	1	1	00 39
0	1	0	1	1	1	00 3A
1	1	0	1	1	1	00 3B
0	0	1	1	1	1	00 3C
1	0	1	1	1	1	00 3D
0	1	1	1	1	1	00 3E
1	1	1	1	1	1	00 3F

0: Interruptor OFF 1: Interruptor ON

SW5				Display de datos
1	2	3	4	
0	0	0	0	00 00
1	0	0	0	00 01
0	1	0	0	00 02
1	1	0	0	00 03
0	0	1	0	00 04
1	0	1	0	00 05
0	1	1	0	00 06
1	1	1	0	00 07
0	0	0	1	00 08
1	0	0	1	00 09
0	1	0	1	00 0A
1	1	0	1	00 0b
0	0	1	1	00 0C
1	0	1	1	00 0d
0	1	1	1	00 0E
1	1	1	1	00 0F

0: Interruptor OFF 1: Interruptor ON

SW8			Display de datos
1	2	3	
0	0	0	00 00
1	0	0	00 01
0	1	0	00 02
1	1	0	00 03
0	0	1	00 04
1	0	1	00 05
0	1	1	00 06
1	1	1	00 07

0: Interruptor OFF 1: Interruptor ON

SW4, SW9, SW10		Display de datos
1	2	
0	0	00 00
1	0	00 01
0	1	00 02
1	1	00 03

[Unidad interior - Información de configuración de modelo] (Código requerido "162")

Display de datos

0 0 * *

Vea la tabla a la derecha.

Display	Estado de configuración de modelo	Display	Estado de configuración de modelo
00	PSA-RP•GA, PSH-PGAH	20	
01		21	PKA-RP•FAL, PKH-P•FALH
02	PEAD-RP•EA/GA, PEHD-P•EAH	22	PCA-RP•GA, PCH-P•GAH
03	SEZ-KA•VA	23	
04		24	
05	SLZ-KA•VA(L)	25	
06	PCA-RP•HA	26	
07		27	
08		28	
09	PEH-RP•MYA	29	
0A		2A	
0b		2b	PKA-RP•GAL, PKH-P•GALH
0C		2C	
0d		2d	
0E		2E	
0F		2F	PLA-RP•AA
10		30	
11	PEA-RP•EA	31	PLH-P•AAH
12	MEZ-GA•VA(L)	32	
13		33	
14		34	
15		35	
16		36	
17		37	
18		38	
19		39	
1A		3A	
1b		3b	
1C		3C	
1d		3d	
1E		3E	
1F		3F	

[Unidad interior - Información de configuración de capacidad] (Código requerido "163")

Display de datos

0 0 * *

Vea la tabla a la derecha.

Display	Estado de configuración de capacidad	Display	Estado de configuración de capacidad
00	12	10	112
01	16	11	125
02	22	12	140
03	25	13	160
04	28	14	200
05	32	15	224
06	36	16	250
07	40	17	280
08	45	18	
09	50	19	
0A	56	1A	
0b	63	1b	
0C	71	1C	
0d	80	1d	
0E	90	1E	
0F	100	1F	

[Configuración del N° de par de inalámbrico - (Lado placa Unidad interior)] (Código requerido "165")

Display de datos

0 0 * *

Vea la tabla a la derecha.

Display	Estado de configuración de N° de par
00	No. 0
01	No. 1 J41 desconectado
02	No. 2 J42 desconectado
03	No. 3 J41, J42 desconectado

Función de mantenimiento fácil

- Reduce drásticamente el trabajo de mantenimiento.
 - Le permite verificar la información de operación de las unidades interior y exterior por control remoto.
- Más aún, el uso de un control de operación estable de mantenimiento que fija la frecuencia de operación, le permite una tranquila inspección aún para los modelos inverter.

Función de mantenimiento
Tranquila

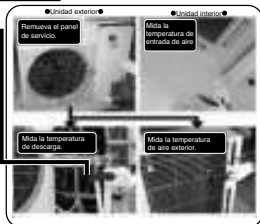

Información de mantenimiento fácil (unidad)

Compressor	Unidad exterior	Unidad interior
1 Tiempo acumulado de operación >10 horas	4 Temp. del intercambiador de calor (°C)	7 Temperatura de aire de entrada (°C)
2 Cantidad de veces ON/OFF >10 veces	5 Temperatura de descarga (°C)	8 Temp. del intercambiador de calor (°C)
3 Corriente de operación (A)	6 Temperatura de aire exterior (°C)	9 Tiempo de operación de los filtros* (Horas)

* El tiempo de operación de los filtros es el tiempo transcurrido desde que el filtro fue reseteado.

14-1. MÉTODO DE OPERACIÓN DEL MODO MANTENIMIENTO

* Si va a utilizar los "Estándares de Item de Inspección", configure el flujo de aire en "Alto" antes de activar el modo de mantenimiento.

● Cambiando al modo de mantenimiento

El modo de mantenimiento puede ser activado tanto con el equipo operando como apagado. No puede ser activado durante el test run.

* La información de mantenimiento puede ser vista aún si el acondicionador de aire es detenido.

■ Información de botones del control remoto

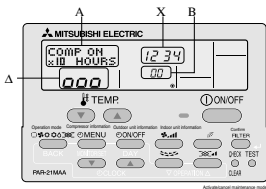

- (1) Presione el botón **(TEST)** durante tres segundos para pasar al modo de mantenimiento.

[Display A] MAINTENANCE

Si no es necesaria la operación estable o si desea verificar la información con el acondicionador de aire detenido, saltee el paso (4).

● Operación a frecuencia fija

La frecuencia de operación puede fijarse para estabilizar la operación del modelo inverter. Si el acondicionador de aire está actualmente detenido, arránquelo con esta operación.

- (2) Presione el botón **(MODE)** para seleccionar el modo de operación deseado.

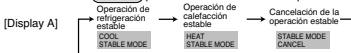

- (3) Presione el botón **(FILTER)** (↕) para confirmar la configuración.

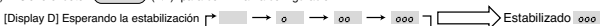

Después de 10 a 20 minutos

● **Medición de datos**

Cuando la operación se estabiliza, mida la información de opción como se indica abajo.

➔(4) Presione los botones [TEMP] (▽) y (△) para seleccionar la dirección de refrigerante deseada.

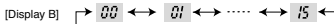

➔(5) Seleccione el tipo de datos a exhibir.

Después de seleccionarlos, vaya al paso (6).

Información del compresor

Botón (⊕) MENU

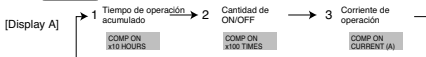

Información de la unidad exterior

Botón (⊕) ON/OFF



Información de la unidad exterior

Botón (⊕) FILTER

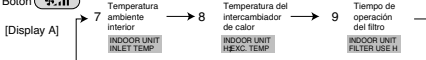

(6) Presione el botón (⊕) FILTER (↔) para confirmar la configuración.

[Ejemplo de display para el tiempo de operación acumulado]

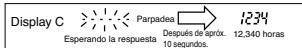

(7) La información es exhibida en el display (en C)

Para verificar la inforación de cada ítem, repita los pasos (5) a (7).

(8) Para cancelar el modo de mantenimiento, presione el botón (TEST) por tres segundos o presione el botón (⊖) ON/OFF.

■ Refrigerant address

Sistema refrigerante simple.

En el caso del sistema refrigerante simple, la dirección de refrigerante es "00" y no se requiere operación. Las unidades simultáneas Dobles, Triples y Cuádruples corresponden a esta categoría (sistema refrigerante simple).

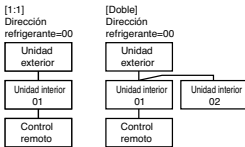

Sistema refrigerante múltiple (control de grupo)

Hasta 16 sistemas refrigerantes (16 unidades exteriores) pueden ser conectadas como un grupo por un control remoto. Para verificar o configurar las direcciones refrigerantes.

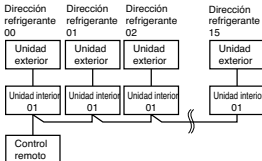

2. GUIA PARA LA CONDICIÓN DE OPERACIÓN

		Item de inspección		Resultado	
Alimentación	Cable conexión	Disyuntor	Bueno	Retightened	
		Bloque de terminales	Unidad exterior	Bueno	Retightened
			Unidad interior	Bueno	Retightened
		(Resistencia de aislación)			MΩ
		(Tensión)			V
Compresor		1 Tiempo de operación acumulado			Tiempo
		2 Cantidad de ON/OFF			Veces
		3 Corriente			A
Unidad exterior	Temperatura	4 Refrigeración/Temperatura del intercambiador de calor	FRIO °C	CALOR °C	
		5 Refrigeración/Temperatura de descarga	FRIO °C	CALOR °C	
	Limpieza	6 Temperatura de aire exterior (Temperatura de descarga de aire)	FRIO °C	CALOR °C	
		Apariencia Intercambiador de calor	Bueno	Requiere limpieza	
		Sonido/vibración	No hay	Presente	
Unidad interior	Temperatura	7 Temperatura de entrada de aire (Temperatura de descarga de aire)	FRIO °C	CALOR °C	
		8 Refrigeración/Temperatura del intercambiador de calor	FRIO °C	CALOR °C	
		9 Tiempo de operación del filtro*			Time
	Limpieza	Panel decorativo	Bueno	Requiere limpieza	
		Filtro	Bueno	Requiere limpieza	
		Ventilador Intercambiador de calor	Bueno	Requiere limpieza	
		Sonido/vibración	No hay	Presente	

* El tiempo de operación del filtro es el tiempo transcurrido desde que el filtro fué reseteado.

Area	Item de verificación	Determinación	
		Frio	Calor
Normal	Estado de operación normal		
Inspección de filtro	El filtro puede estar obstruido. *1		
Inspección A	El rendimiento ha caído. Se requiere una inspección detallada.		
Inspección B	La cantidad de refrigerante está disminuyendo.		
Inspección C	El filtro del intercambiador de calor interior puede estar obstruido.		

* La determinación de arriba es sólo una guía basada en las condiciones estándar Japonesas. Puede ser cambiada dependiendo de la temperatura interior y exterior.

Resultado

Puntos a Verificar

Ingrese las diferencias de temperatura entre 5, 4, 7 y 8 en el gráfico dado abajo.

El estado de operación se determina de acuerdo a las áreas graficadas en el gráfico.

Para medición de datos, configure la velocidad del ventilador en Alta (Hi) antes de activar el modo de mantenimiento.

Clasificación	Item	Resultado		
Frio	Inspección	¿Se exhibe "D000" estable en el control remoto?	Estable	Inestable
	Diferencia de temperatura	(5 Temperatura de descarga) - (4 Temperatura del intercambiador de calor exterior)		°C
		(7 Temperatura de ingreso de aire interior) - (8 Temperatura del intercambiador de calor interior)		°C
Calor	Inspección	¿Se exhibe "D000" estable en el control remoto?	Estable	Inestable
	Diferencia de temperatura	(5 Temperatura de descarga) - (8 Temperatura del intercambiador de calor interior)		°C
		(8 Temperatura del intercambiador de calor interior) - (7 Temperatura de ingreso de aire interior)		°C

* La operación a frecuencia fija puede no ser posible bajo los siguientes rangos de temperatura.

A) En modo refrigeración, la temperatura de ingreso de aire exterior es de 40°C o superior o la temperatura de ingreso de aire interior es de 23°C o inferior.

B) En el modo calefacción, la temperatura de ingreso de aire exterior es 20°C o superior o la temperatura de ingreso de aire interior es de 25°C o inferior.

* Si se opera al acondicionador de aire a un rango de temperatura que no sean los de arriba, pero la operación no no se estabiliza después de 30 minutos o más, efectúe una inspección.

* En el modo calefacción, el estado de operación puede variar debido al formado de hielo en el intercambiador de calor exterior.

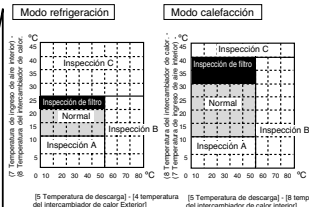

ASISTENTE TÉCNICO SMS

Mr.SLIM

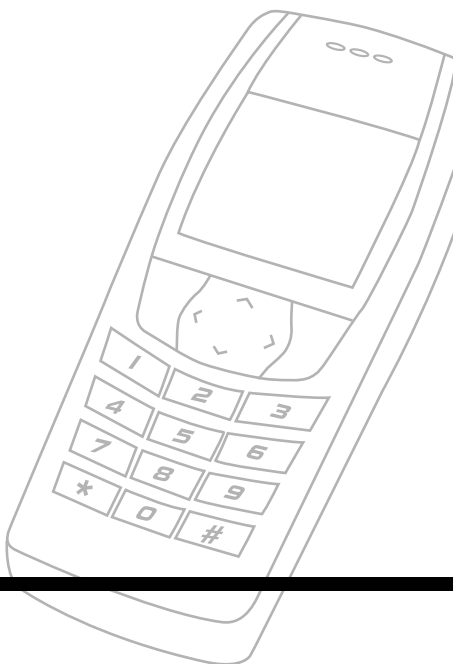

SERVICIO DE CONSULTA DE CÓDIGOS DE ERROR, MEDIANTE MENSAJES DE TEXTO SMS.

Envíe un SMS siguiendo las instrucciones de este manual al número 7213* y recibirá un SMS con el significado del error que le ayudará a solventar el problema.

*Coste del mensaje 0,30€ más IVA.

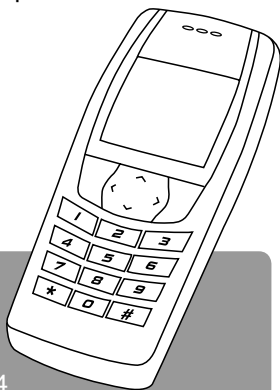

PARA MÁS INFORMACIÓN:

Departamento técnico 902 314 214
www.mitsubishielectric.es

EJEMPLO:

CON CÓDIGO DE ERROR DE 2 DÍGITOS.
Escriba mr seguido de un espacio y el código de error.



Nº DE PITIDOS DE LA UNIDAD INTERIOR
Escriba mr seguido de un espacio, el símbolo # y el numero de pitidos que emita la unidad interior. (Para unidades de control inalámbrico)

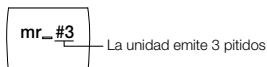

LEDS ROJO Y VERDE DE LA UNIDAD EXTERIOR

Escriba mr seguido de un espacio, e indique los parpadeos de los leds verde y rojo de la siguiente forma.

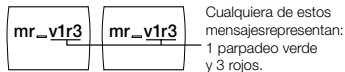

CÓDIGO DE 4 DÍGITOS

Escriba mr seguido de un espacio, y el código de error de 4 dígitos

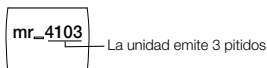





Información

GENERAL DE SERVICIOS

Mitsubishi Electric

Mitsubishi Electric Europe B.V. garantiza en España, los productos que comercializa bajo la marca «Mitsubishi Electric» contra defectos de fabricación y/o funcionamiento en los términos y plazo que se señalan a continuación:

Gama Doméstica y Comercial Mr. Slim:

2 AÑOS **GARANTÍA TOTAL**

3 AÑOS para la sustitución del compresor

Resto de la gama:

6 MESES **GARANTÍA TOTAL**

2 AÑOS para la sustitución de componente averiado

3 AÑOS para la sustitución del compresor



The image shows a warranty form for Mitsubishi Electric. At the top left is the Mitsubishi Electric logo. In the center, the word "GARANTÍA" is written in large, bold letters. To the right of "GARANTÍA" are two small square icons. Below the title, the text reads "HASTA 2 AÑOS DE GARANTÍA TOTAL - 3 AÑOS EN COMPRESOR". The form contains several sections for data entry, including fields for "SERIAL NUMBER" and "MODEL NUMBER". There is a table with columns for "DATE OF PURCHASE", "DATE OF INSTALLATION", "DATE OF SERVICE", and "DATE OF RETURN". The form is designed to be filled out by the customer to claim the warranty.

Estos plazos se computarán desde la fecha de compra del producto, no siendo acumulables.

La garantía total comprende la reparación del producto averiado o, caso de ser necesaria, su sustitución, incluyendo no solo la pieza sino también el transporte y la mano de obra. Fuera de los casos de garantía total, la sustitución incluye únicamente el suministro, sin cargo, de cualquier pieza defectuosa, quedando excluidos el desplazamiento y la mano de obra.

Quedan en todo caso excluidas de la presente garantía las averías no imputables a los defectos de fabricación y/o de los materiales, así como las originadas por mala instalación o manipulación por personal no autorizado expresamente por Mitsubishi Electric Europe B.V., así como las provocadas por tensiones de alimentación indebidas o cualquier otra circunstancia ajena a Mitsubishi Electric Europe B.V.

Esta garantía comercial es otorgada por MITSUBISHI ELECTRIC EUROPE B.V. específicamente al comprador mencionado en el dorso. En caso de que el comprador tenga la condición de consumidor, la presente garantía comercial se entiende sin perjuicio y adicionalmente a los derechos que el consumidor pueda reclamar conforme a lo dispuesto en la Ley 23/2003.

Para ejercitar esta garantía comercial se deberá presentar este documento de garantía debidamente cumplimentado ante el servicio técnico autorizado de Mitsubishi Electric Europe B.V., que podrá exigir la presentación de la factura de compra del aparato junto a este documento.

*** Los datos facilitados por medio del presente formulario serán recogidos en un fichero titularidad de MITSUBISHI ELECTRIC EUROPE B.V., Sucursal en España con domicilio en Ctra. de Rubí 76-80, 08173 Sant Cugat del Vallés (Barcelona). Este fichero tiene únicamente la finalidad de gestión de la garantía de los productos adquiridos.**

Exclusivamente tendrán acceso a los datos facilitados, los empleados de MITSUBISHI ELECTRIC EUROPE, B.V., Sucursal en España. El ejercicio de sus derechos de acceso, rectificación, cancelación y oposición se podrá realizar enviando una comunicación a la dirección antes indicada, o bien enviando un mensaje de correo electrónico a la dirección aire.acondicionado@sp.mee.com incluyendo la palabra LOPD en la línea Asunto.

Condiciones de **GARANTÍA / CONTACTO**

