

September 2011

No.OCH472

REVISED EDITION-A



# TECHNICAL & SERVICE MANUAL

## R410A

Outdoor unit

[Model names]

[Service Ref.]

SUZ-KA25VA2

**SUZ-KA25VA2.TH**

SUZ-KA35VA2

**SUZ-KA35VA2.TH**

SUZ-KA50VA2

**SUZ-KA50VA2.TH**

SUZ-KA60VA2

**SUZ-KA60VA2.TH**

SUZ-KA71VA2

**SUZ-KA71VA2.TH**

Revision:

- Errors in "11. TROUBLESHOOTING" have been corrected in REVISED EDITION-A.
- Some descriptions have been modified.

- Please void OCH472.

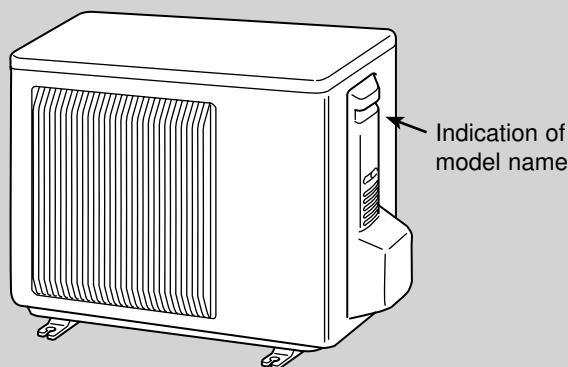

SUZ-KA25VA2.TH  
SUZ-KA35VA2.TH

## CONTENTS

|   |    |
|---|----|
| 1. COMBINATION OF INDOOR AND OUTDOOR UNITS..... | 2  |
| 2. TECHNICAL CHANGES .....                      | 3  |
| 3. PART NAMES AND FUNCTIONS.....                | 6  |
| 4. SPECIFICATION.....                           | 7  |
| 5. NOISE CRITERIA CURVES.....                   | 9  |
| 6. OUTLINES AND DIMENSIONS.....                 | 10 |
| 7. WIRING DIAGRAM.....                          | 13 |
| 8. REFRIGERANT SYSTEM DIAGRAM.....              | 17 |
| 9. ACTUATOR CONTROL.....                        | 21 |
| 10. SERVICE FUNCTIONS.....                      | 22 |
| 11. TROUBLESHOOTING.....                        | 22 |
| 12. DISASSEMBLY INSTRUCTIONS.....               | 63 |

### NOTE:

This service manual describes technical data of the outdoor units.  
RoHS compliant products have <G> mark on the spec name plate.  
For servicing of RoHS compliant products, refer to the RoHS Parts List.

**PARTS CATALOG (OCB472)**

# 1 COMBINATION OF INDOOR AND OUTDOOR UNITS

## 1-1. INDOOR UNIT SERVICE MANUAL

|                                   | Indoor unit      |                    | Outdoor unit   |            |            |            |   |
|-----------------------------------|------------------|--------------------|----------------|------------|------------|------------|---|
|                                   |                  |                    | Heat pump type |            |            |            |   |
|                                   | Service Ref.     | Service Manual No. | SUZ-           |            |            |            |   |
| KA25VA2.TH                        |                  |                    | KA35VA2.TH     | KA50VA2.TH | KA60VA2.TH | KA71VA2.TH |   |
| Heat pump without electric heater | SLZ-KA25VA(L).TH | OC320              | ○              | —          | —          | —          | — |
|                                   | SLZ-KA35VA(L).TH |                    | —              | ○          | —          | —          | — |
|                                   | SLZ-KA50VA(L).TH |                    | —              | —          | ○          | —          | — |
|                                   | SLZ-KA25VAQ.TH   | OCH493             | ○              | —          | —          | —          | — |
|                                   | SLZ-KA35VAQ.TH   |                    | —              | ○          | —          | —          | — |
|                                   | SLZ-KA50VAQ.TH   |                    | —              | —          | ○          | —          | — |
|                                   | SEZ-KD25VA(L).TH | HWE0711            | ○              | —          | —          | —          | — |
|                                   | SEZ-KD35VA(L).TH |                    | —              | ○          | —          | —          | — |
|                                   | SEZ-KD50VA(L).TH |                    | —              | —          | ○          | —          | — |
|                                   | SEZ-KD60VA(L).TH |                    | —              | —          | —          | ○          | — |
|                                   | SEZ-KD71VA(L).TH |                    | —              | —          | —          | —          | ○ |
|                                   | SEZ-KD25VAQ.TH   | HWE1008            | ○              | —          | —          | —          | — |
|                                   | SEZ-KD35VAQ.TH   |                    | —              | ○          | —          | —          | — |
|                                   | SEZ-KD50VAQ.TH   |                    | —              | —          | ○          | —          | — |
|                                   | SEZ-KD60VAQ.TH   |                    | —              | —          | —          | ○          | — |
|                                   | SEZ-KD71VAQ.TH   |                    | —              | —          | —          | —          | ○ |
|                                   | MFZ-KA25VA-E4    | OB409              | ○              | —          | —          | —          | — |
|                                   | MFZ-KA35VA-E4    |                    | —              | ○          | —          | —          | — |
| MFZ-KA50VA-E4                     | —                |                    | —              | ○          | —          | —          |   |

(NOTE) Please refer to the service manual of indoor unit or the technical data book for the combination data.

**INFORMATION FOR THE AIR CONDITIONER WITH R410A REFRIGERANT**

- This room air conditioner adopts an HFC refrigerant (R410A) which never destroys the ozone layer.
  - Pay particular attention to the following points, though the basic installation procedure is same as that for R22 conditioners.
- ① As R410A has working pressure approximate 1.6 times as high as that of R22, some special tools and piping parts/materials are required. Refer to the table below.
  - ② Take sufficient care not to allow water and other contaminations to enter the R410A refrigerant during storage and installation, since it is more susceptible to contaminations than R22.
  - ③ For refrigerant piping, use clean, pressure-proof parts/materials specifically designed for R410A. (Refer to 2. Refrigerant piping.)
  - ④ Composition change may occur in R410A since it is a mixed refrigerant. When charging, charge liquid refrigerant to prevent composition change.

|                 |                                       | New refrigerant               | Previous refrigerant |
|-----------------|---------------------------------------|-------------------------------|----------------------|
| Refrigerant     | Refrigerant                           | R410A                         | R22                  |
|                 | Composition (Ratio)                   | HFC-32: HFC-125 (50%:50%)     | R22 (100%)           |
|                 | Refrigerant handling                  | Pseudo-azeotropic refrigerant | Single refrigerant   |
|                 | Chlorine                              | Not included                  | Included             |
|                 | Safety group (ASHRAE)                 | A1/A1                         | A1                   |
|                 | Molecular weight                      | 72.6                          | 86.5                 |
|                 | Boiling point (°C)                    | -51.4                         | -40.8                |
|                 | Steam pressure [25°C](Mpa)            | 1.557                         | 0.94                 |
|                 | Saturated steam density [25°C](Kg/m³) | 64                            | 44.4                 |
|                 | Combustibility                        | Non combustible               | Non combustible      |
|                 | ODP ※1                                | 0                             | 0.055                |
|                 | GWP ※2                                | 1730                          | 1700                 |
|                 | Refrigerant charge method             | From liquid phase in cylinder | Gas phase            |
|                 | Additional charge on leakage          | Possible                      | Possible             |
| Refrigerant oil | Kind                                  | Incompatible oil              | Compatible oil       |
|                 | Color                                 | None                          | Light yellow         |
|                 | Smell                                 | None                          | None                 |

※1: Ozone Depletion Potential : based on CFC-11

※2: Global Warming Potential : based on CO<sub>2</sub>

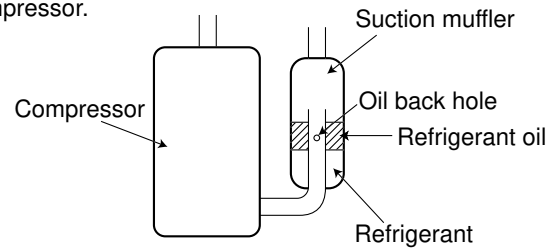
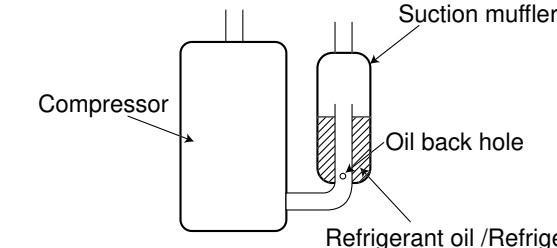
|            | New Specification  | Current Specification   |
|------------|--|---|
| Compressor | <p>The incompatible refrigerant oil easily separates from refrigerant and is in the upper layer inside the suction muffler. Raising position of the oil back hole enables to back the refrigerant oil of the upper layer to flow back to the compressor.</p>  | <p>Since refrigerant and refrigerant oil are compatible with each other, refrigerant oil backs to the compressor through the lower position oil back hole.</p>  |

**NOTE** : The unit of pressure has been changed to MPa on the international system of units (SI unit system).

The conversion factor is: **1 (MPa [Gauge]) =10.2 (kgf/cm<sup>2</sup> [Gauge])**

### Conversion chart of refrigerant temperature and pressure

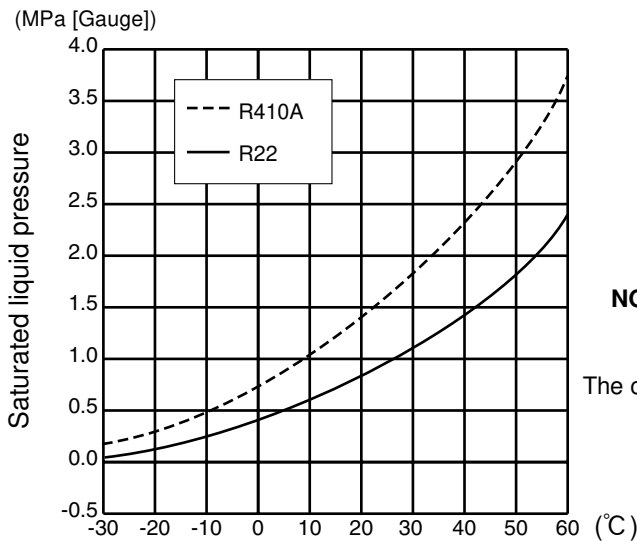

**NOTE:** The unit of pressure has been changed to MPa on the international system of units (SI unit system).

The conversion factor is: **1 (MPa [Gauge]) = 10.2 (kgf/cm<sup>2</sup> [Gauge])**

#### 1. Tools dedicated for the air conditioner with R410A refrigerant

The following tools are required for R410A refrigerant. Some R22 tools can be substituted for R410A tools.

The diameter of the service port on the stop valve in outdoor unit has been changed to prevent any other refrigerant being charged into the unit. Cap size has been changed from 7/16 UNF with 20 threads to 1/2 UNF with 20 threads.

| R410A tools                               | Can R22 tools be used? | Description   |
|---|------------------------|---|
| Gauge manifold                            | No                     | R410A has high pressures beyond the measurement range of existing gauges. Port diameters have been changed to prevent any other refrigerant from being charged into the unit. |
| Charge hose                               | No                     | Hose material and cap size have been changed to improve the pressure resistance.  |
| Gas leak detector                         | No                     | Dedicated for HFC refrigerant.  |
| Torque wrench                             | Yes                    | 6.35 mm and 9.52 mm   |
|   | No                     | 12.7 mm and 15.88 mm  |
| Flare tool                                | Yes                    | Clamp bar hole has been enlarged to reinforce the spring strength in the tool.  |
| Flare gauge                               | New                    | Provided for flaring work (to be used with R22 flare tool).   |
| Vacuum pump adapter                       | New                    | Provided to prevent the back flow of oil. This adapter enables you to use vacuum pumps.   |
| Electronic scale for refrigerant charging | New                    | It is difficult to measure R410A with a charging cylinder because the refrigerant bubbles due to high pressure and high-speed vaporization                                    |

No: Not substitutable for R410A    Yes: Substitutable for R410A

## 2. Refrigerant piping

### ① Specifications

Use the refrigerant pipes that meet the following specifications.

| Pipe       | Outside diameter | Wall thickness | Insulation material   |
|------------|------------------|----------------|---|
|            | mm               | mm             |   |
| For liquid | 6.35             | 0.8            | Heat resisting foam plastic<br>Specific gravity 0.045 Thickness<br>8 mm |
|            | 9.52             | 0.8            |   |
| For gas    | 9.52             | 0.8            |   |
|            | 12.7             | 0.8            |   |
|            | 15.88            | 1.0            |   |

- Use a copper pipe or a copper-alloy seamless pipe with a thickness of 0.8 mm. Never use any pipe with a thickness less than 0.8mm, as the pressure resistance is insufficient.

### ② Flaring work and flare nut

Flaring work for R410A pipe differs from that for R22 pipe.

For details of flaring work, refer to Installation manual "FLARING WORK".

| Pipe diameter (mm) | Dimension of flare nut (mm) |     |
|--------------------|-----------------------------|-----|
|                    | R410A                       | R22 |
| 6.35               | 17                          | 17  |
| 9.52               | 22                          | 22  |
| 12.7               | 26                          | 24  |
| 15.88              | 29                          | 27  |

## 3. Refrigerant oil

Apply the special refrigerant oil (accessories: packed with indoor unit) to the flare and the union seat surfaces.

## 4. Air purge

- Do not discharge the refrigerant into the atmosphere.  
Take care not to discharge refrigerant into the atmosphere during installation, reinstallation, or repairs to the refrigerant circuit.
- Use the vacuum pump for air purging for the purpose of environmental protection.

## 5. Additional charge

For additional charging, charge the refrigerant from liquid phase of the gas cylinder.

If the refrigerant is charged from the gas phase, composition change may occur in the refrigerant inside the cylinder and the outdoor unit. In this case, ability of the refrigerating cycle decreases or normal operation can be impossible. However, charging the liquid refrigerant all at once may cause the compressor to be locked. Thus, charge the refrigerant slowly.

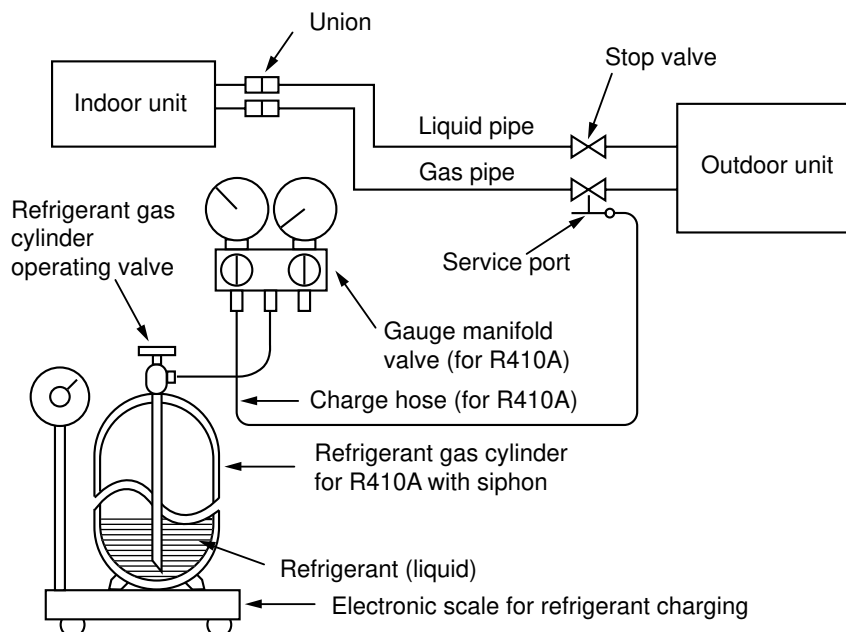

**SUZ-KA25VA2.TH SUZ-KA35VA2.TH**

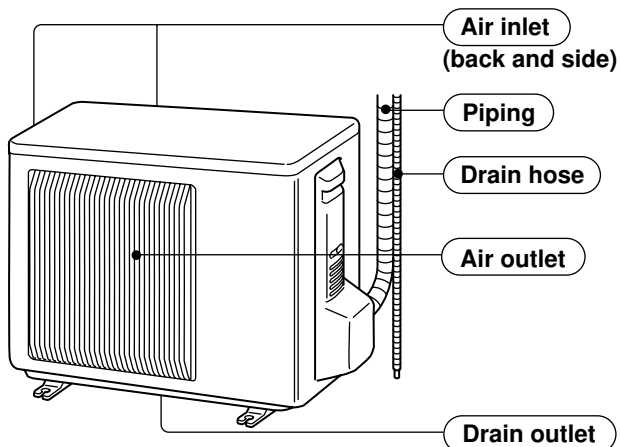

**SUZ-KA50VA2.TH SUZ-KA60VA2.TH**

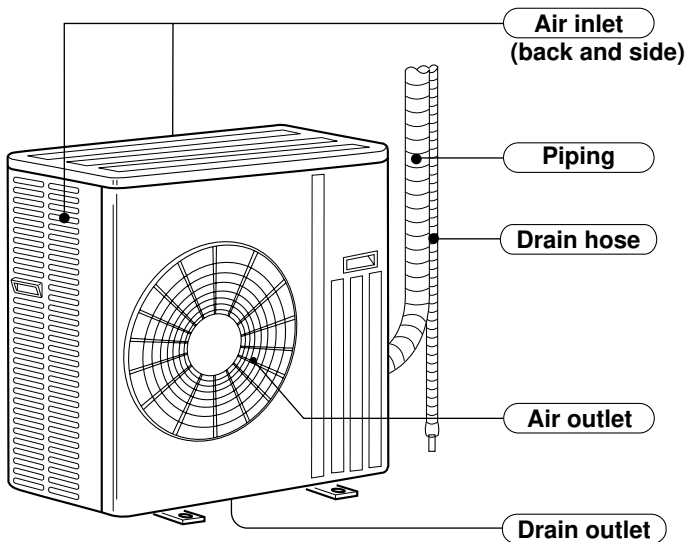

**SUZ-KA71VA2.TH**

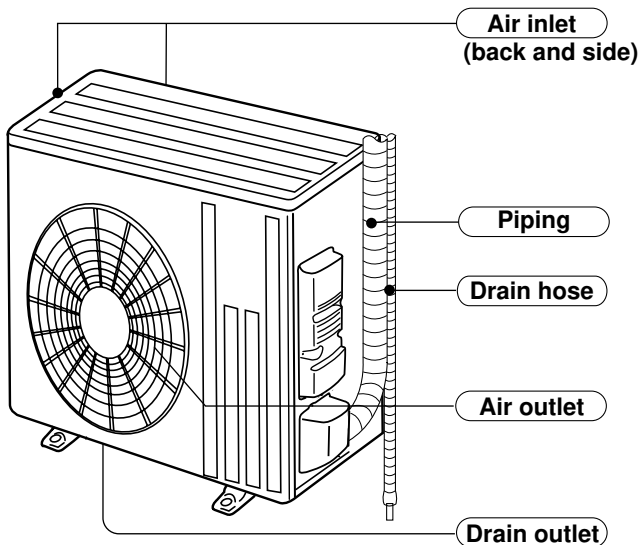

| Model          | SUZ-KA25/35VA2.TH | SUZ-KA50/60VA2.TH | SUZ-KA71VA2.TH |
|----------------|-------------------|-------------------|----------------|
| ① Drain socket | 1                 | 1                 | 1              |
| ② Drain cap    | -                 | 2                 | -              |

## 4

## SPECIFICATION

| Outdoor Service Ref. |  | SUZ-KA25VA2.TH             |  | SUZ-KA35VA2.TH             |  | SUZ-KA50VA2.TH             |  | SUZ-KA60VA2.TH             |  | SUZ-KA71VA2.TH             |  |                        |
|----------------------|--|----------------------------|--|----------------------------|--|----------------------------|--|----------------------------|--|----------------------------|--|------------------------|
| Function             |  | Cooling                    | Heating                                      | Cooling                    | Heating                                      | Cooling                    | Heating                                      | Cooling                    | Heating                                      | Cooling                    | Heating                                      |                        |
| Power supply         |  | Single phase<br>230V, 50Hz |  | Single phase<br>230V, 50Hz |  | Single phase<br>230V, 50Hz |  | Single phase<br>230V, 50Hz |  | Single phase<br>230V, 50Hz |  |                        |
| Electrical data      | Starting current *1                    | A                          | 3.65   |                            | 4.75   |                            | 6.75   |                            | 9.75   |                            | 8.89   |                        |
|                      | Compressor motor current *1            | A                          | 2.74   | 3.37                       | 4.22   | 4.42                       | 6.45   | 6.05                       | 8.05   | 9.45                       | 8.00   | 8.07                   |
|                      | Fan motor current *1                   | A                          | 0.31   | 0.28                       | 0.33   | 0.33                       | 0.30   |                            | 0.30   |                            | 0.83   | 0.82                   |
| Compressor           | Model                                  | KNB073FFDH(C)              |  | KNB092FFAH(C)              |  | SNB130FGBH(T)              |  | SNB130FGBH(T)              |  | SNB172FEKMT                |  |                        |
|                      | Output                                 | W                          | 550  |                            | 650  |                            | 900  |                            | 900  |                            | 1200   |                        |
|                      | Winding resistance (at 20°C)           | Ω                          | U-V 1.70                                     | U-W 1.70                   | U-V 1.91                                     | U-W 1.91                   | U-V 0.98                                     | U-W 0.98                   | U-V 0.98                                     | U-W 0.98                   | U-V 1.04                                     | U-W 1.04               |
| Fan motor            | Model                                  | RC0J50-DB                  |  | RC0J50-DB                  |  | RC0J60-AA                  |  | RC0J60-AA                  |  | RC0J60-BC                  |  |                        |
|                      | Winding resistance(at 20°C)            | Ω                          | WHT-BLK 37.0<br>BLK-RED 37.0<br>RED-WHT 37.0 |                            | WHT-BLK 37.0<br>BLK-RED 37.0<br>RED-WHT 37.0 |                            | WHT-BLK 15.2<br>BLK-RED 15.2<br>RED-WHT 15.2 |                            | WHT-BLK 15.2<br>BLK-RED 15.2<br>RED-WHT 15.2 |                            | WHT-BLK 15.0<br>BLK-RED 15.0<br>RED-WHT 15.0 |                        |
|                      | Air flow(High/Low*)                    | m³/h                       | 2,058  | 1,938                      | 2,004  |                            | 2,940/1,650*                                 | 2,940/2,210*               | 2,940/1,650*                                 | 2,940/2,210*               | 3,425/3,006<br>/1,512*                       | 2,892/2,892<br>/2,280* |
| Dimensions W×H×D     | mm                                     | 800×550×285                |  | 800×550×285                |  | 840×850×330                |  | 840×850×330                |  | 840×880×330                |  |                        |
| Weight               | kg                                     | 30                         |  | 33                         |  | 53                         |  | 53                         |  | 53                         |  |                        |
| Special remarks      | Sound level *1                         | dB                         | 46   |                            | 47   | 48                         | 53/51*                                       | 55/53*                     | 53/51*                                       | 55/53*                     | 55*  | 55*                    |
|                      | Fan speed(High*/Low*, High*/Med*/Low*) | rpm                        | 810*/650*<br>880*/810*/650*                  |                            | 840*/760*<br>880*/800*/630*                  |                            | 840/480*                                     | 800/620*                   | 840/480*                                     | 800/620*                   | 950/840/450*                                 | 810/810/650*           |
|                      | Fan speed regulator                    |                            | 2  | 3                          | 2  | 3                          | 2  |                            | 2  |                            | 3  |                        |
|                      | Refrigerant filling capacity(R410A)    | kg                         | 0.80   |                            | 1.05   |                            | 1.60   |                            | 1.80   |                            | 1.80   |                        |
|                      | Refrigerating oil (Model)              | cc                         | 320 (NEO22)                                  |                            | 320 (NEO22)                                  |                            | 450 (NEO22)                                  |                            | 450 (NEO22)                                  |                            | 400 (FV50S)                                  |                        |

NOTE : Test conditions are based on ISO 5151

Cooling : Indoor D.B. 27°C W.B. 19°C

Outdoor D.B. 35°C W.B. 24°C

Heating : Indoor D.B. 20°C W.B. 15°C

Outdoor D.B. 7°C W.B. 6°C

Refrigerant piping length (one way): 5m

\*1 Measured under rated operating frequency.

\* Reference value

Specifications and rating conditions of main electric parts

SUZ-KA25VA2.TH SUZ-KA35VA2.TH  
 SUZ-KA50VA2.TH SUZ-KA60VA2.TH  
 SUZ-KA71VA2.TH

| Item                            | Model              | SUZ-KA25VA2.<br>TH          | SUZ0KA35VA2.<br>TH            | SUZ-KA50VA2.<br>TH            | SUZ-KA60VA2.<br>TH | SUZ-KA71VA2.<br>TH |
|---------------------------------|--------------------|-----------------------------|-------------------------------|-------------------------------|--------------------|--------------------|
| Current transformer             | (CT)               | 20A                         |                               |                               | -                  | -                  |
|                                 | (CT1, 2)           |                             |                               |                               | ETQ19Z68AY         | -                  |
|                                 | (CT61)             |                             |                               |                               | ETQ19Z53AY         | -                  |
|                                 | (CT761, CT781)     | 15A                         |                               |                               | -                  | -                  |
| Smoothing capacitor             | (C61)              | -                           |                               | 620 $\mu$ F 420V              | -                  | -                  |
|                                 | (C62, C63)         | 620 $\mu$ F 420V            |                               |                               | -                  | -                  |
|                                 | (CB1, 2, 3)        |                             |                               |                               | 560 $\mu$ F 450V   | 560 $\mu$ F 350V   |
| Diode module                    | (DB61)             | 15A 600V                    |                               | 25A 600V                      | -                  | -                  |
|                                 | (DB65)             | 25A 600V                    |                               |                               | -                  | -                  |
| Fuse                            | (F61)              | T20A L250V                  |                               |                               | -                  | -                  |
|                                 | (F62)              |                             |                               |                               | -                  | T20A L250V         |
|                                 | (F63)              |                             |                               |                               | -                  | -                  |
|                                 | (F64)              |                             |                               |                               | 250V 2A            | -                  |
|                                 | (F701, F801, F901) | T3.15A L250V                |                               |                               |                    | -                  |
|                                 | (F911)             |                             |                               |                               | 250V 1A            | -                  |
| Inteligent power module         | (IPM)              | 15A 600V                    |                               | 20A 600V                      | 15A 600V           | 20A 600V           |
|                                 | (HC930)            |                             |                               |                               | 3A 450V            | -                  |
|                                 | (IC932)            |                             |                               | -                             |                    | 5A 600V            |
| Power factor controller         | (PFC)              |                             |                               |                               | PS51259-A          | 20A 600V           |
| Expansion valve coil            | (LEV)              | DC12V                       |                               |                               |                    |                    |
| High pressure switch            | (HPS)              |                             |                               |                               | ACB-DB156 (for R2) | -                  |
| Reactor                         | (L61)              | 23mH                        |                               |                               |                    | -                  |
|                                 | (L)                |                             |                               |                               | 340 $\mu$ H 20A    | 340 $\mu$ H        |
| Current-detecting resistor      | (R61)              | 45m $\Omega$ 5W (1 element) | 100m $\Omega$ 5W (2 elements) |                               |                    |                    |
|                                 | (R61, R62)         |                             |                               | 180m $\Omega$ 5W (2 elements) |                    |                    |
|                                 | (R64A, R64B)       |                             |                               |                               | 10 $\Omega$ 10W    |                    |
|                                 | (R825)             | 25m $\Omega$ 5W             |                               |                               |                    | -                  |
|                                 | (R937, R938, R939) | 430m $\Omega$ 2W            |                               |                               | -                  |                    |
| Resistor                        | (R937A, R937B)     |                             |                               | 1.1 $\Omega$ 2W               | 1.1 $\Omega$ 2W 2% | -                  |
|                                 | (RS1~4)            |                             |                               |                               | 0.04 $\Omega$ 7W   | -                  |
| Current-Limiting PTC thermistoe | (PTC64, PTC65)     | 33 $\Omega$                 |                               |                               | -                  | 33 $\Omega$        |
| Terminal block                  | (TB1, TB2)         | 3P                          |                               |                               |                    |                    |
| Relay                           | (X63)              | 3A 250V                     |                               |                               |                    |                    |
|                                 | (X64)              | 20A 250V                    |                               |                               | 20A 250V           | 20A 250V           |
|                                 | (X601)             |                             |                               |                               |                    | 3A 250V            |
|                                 | (X602)             |                             |                               |                               |                    | 3A 250V            |
| Solenoid coil relay             | (SSR61)            |                             |                               |                               | TLP3506            | -                  |
| R.V. coil                       | (21S4)             | AC220-240V                  |                               |                               |                    |                    |
| IGBT                            | (TR821)            | 30A 600V                    |                               |                               | -                  | -                  |

SUZ-KA25VA2.TH

| FAN SPEED | FUNCTION | SPL(dB(A)) | LINE |
|-----------|----------|------------|------|
| High Med. | COOLING  | 46         | ●—●  |
|           | HEATING  | 46         | ○—○  |

Test conditions,

Cooling : Dry-bulb temperature 35°C Wet-bulb temperature (24°C)  
 Heating : Dry-bulb temperature 7°C Wet-bulb temperature 6°C

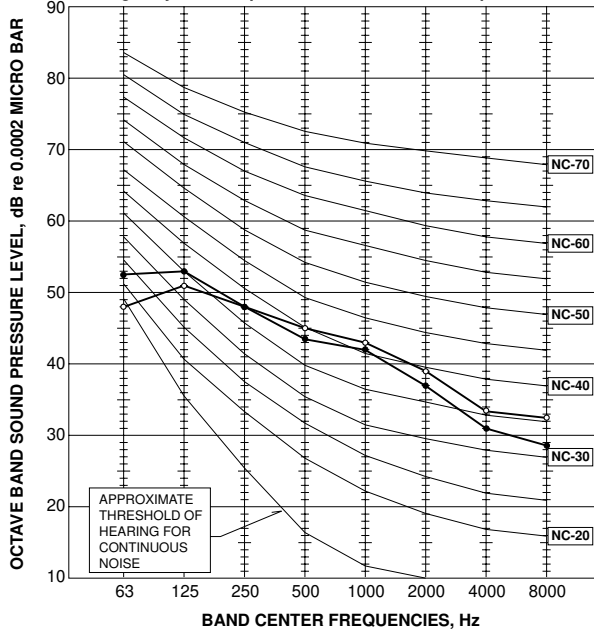

SUZ-KA35VA2.TH

| FAN SPEED | FUNCTION | SPL(dB(A)) | LINE |
|-----------|----------|------------|------|
| High Med. | COOLING  | 47         | ●—●  |
|           | HEATING  | 48         | ○—○  |

Test conditions,

Cooling : Dry-bulb temperature 35°C Wet-bulb temperature (24°C)  
 Heating : Dry-bulb temperature 7°C Wet-bulb temperature 6°C

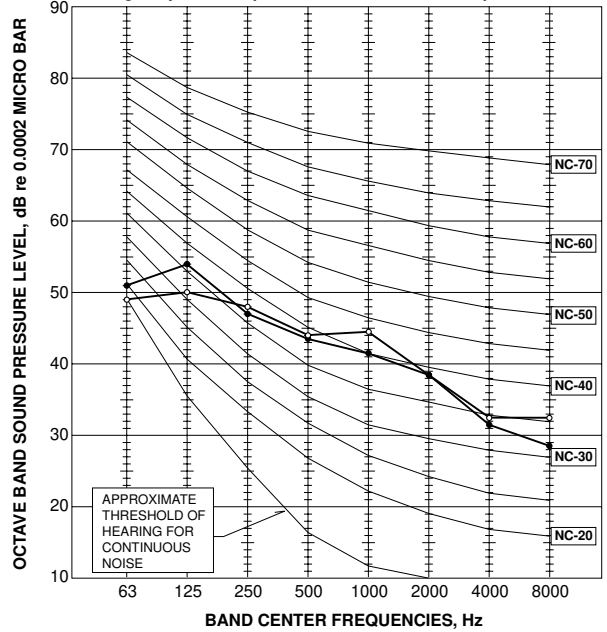

SUZ-KA50VA2.TH SUZ-KA60VA2.TH

| FAN SPEED | FUNCTION | SPL(dB(A)) | LINE |
|-----------|----------|------------|------|
| High      | COOLING  | 53         | ●—●  |
|           | HEATING  | 55         | ○—○  |

Test conditions,

Cooling : Dry-bulb temperature 35°C Wet-bulb temperature (24°C)  
 Heating : Dry-bulb temperature 7°C Wet-bulb temperature 6°C

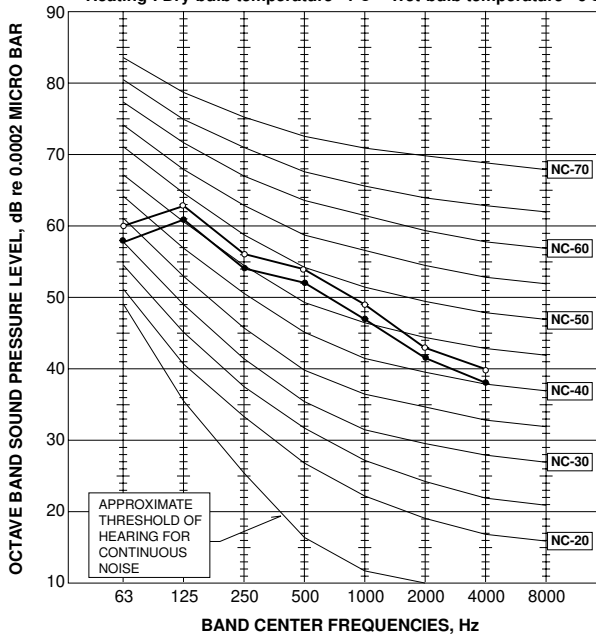

SUZ-KA71VA2.TH

| FAN SPEED | FUNCTION | SPL(dB(A)) | LINE |
|-----------|----------|------------|------|
| High      | COOLING  | 55         | ●—●  |
|           | HEATING  | 55         | ○—○  |

Test conditions,

Cooling : Dry-bulb temperature 35°C Wet-bulb temperature (24°C)  
 Heating : Dry-bulb temperature 7°C Wet-bulb temperature 6°C

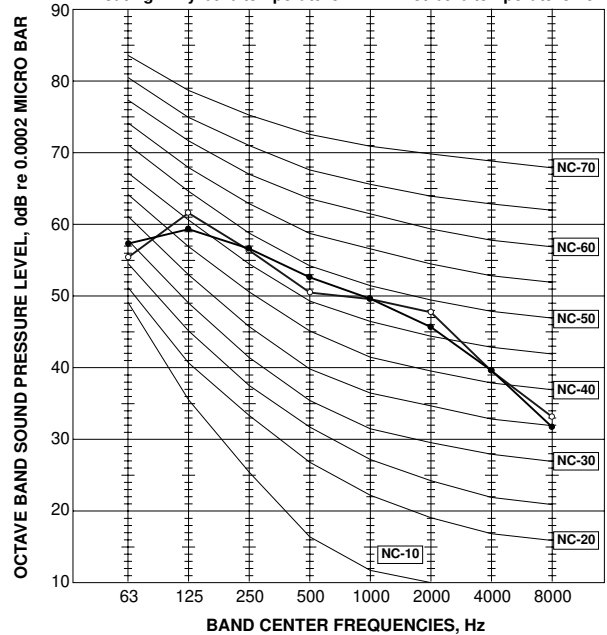

Test conditions

Cooling: Dry-bulb temperature 35°C  
 Heating: Dry-bulb temperature 7°C  
 Wet-bulb temperature 6°C

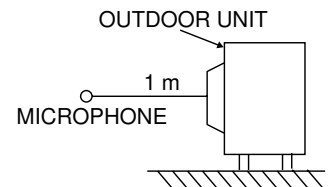

SUZ-KA25VA2.TH SUZ-KA35VA2.TH

Unit: mm

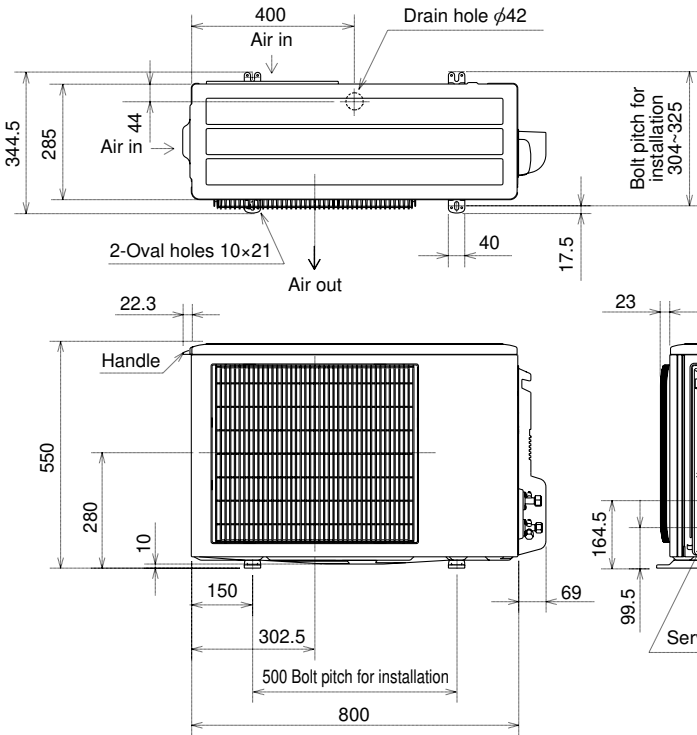

REQUIRED SPACE

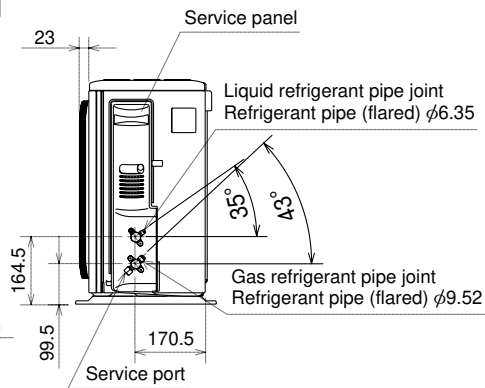
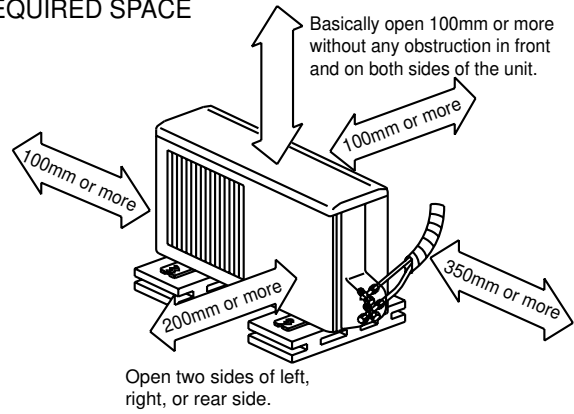

SUZ-KA50VA2.TH SUZ-KA60VA2.TH

Unit: mm

REQUIRED SPACE

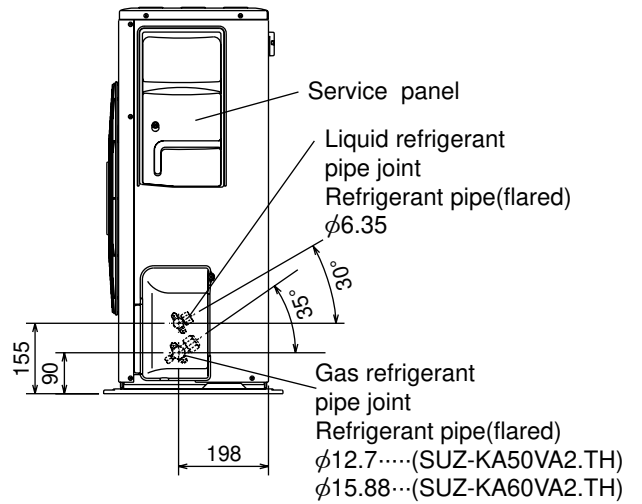
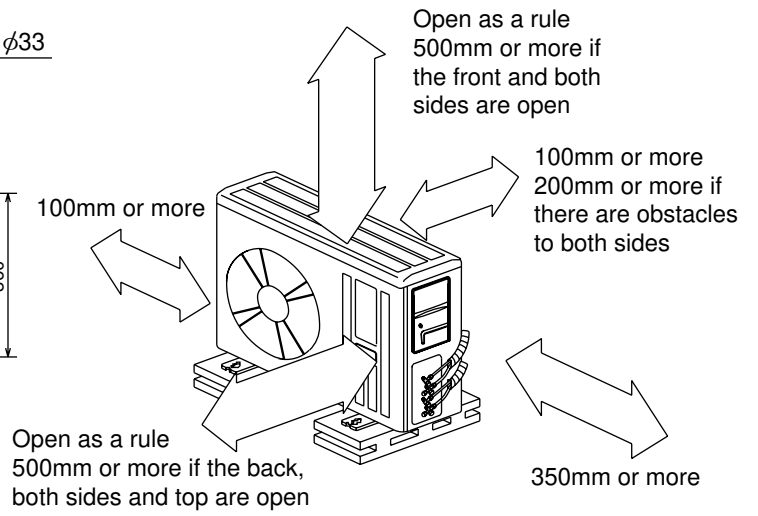
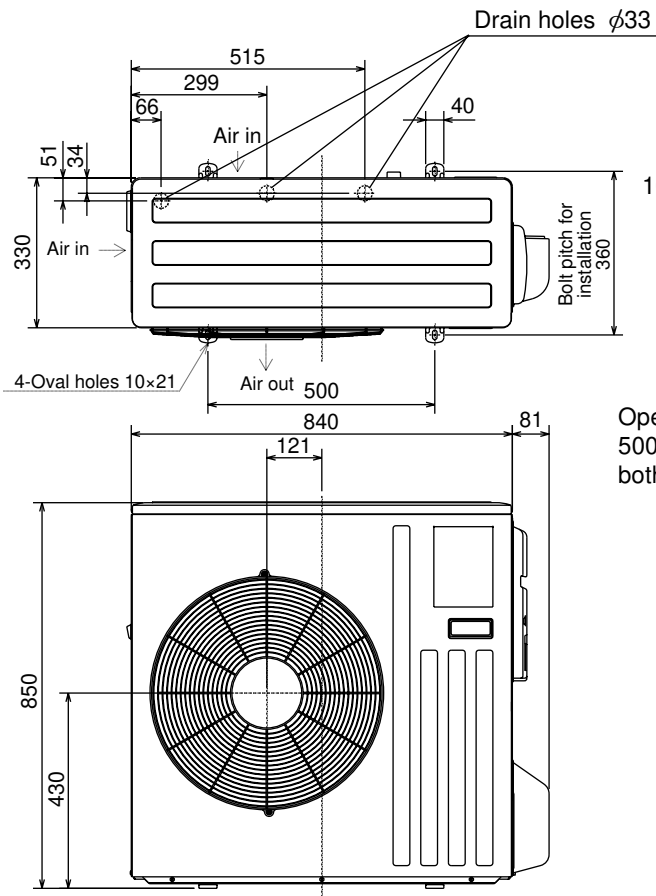

**SUZ-KA71VA2.TH**

Unit: mm

**REQUIRED SPACE**

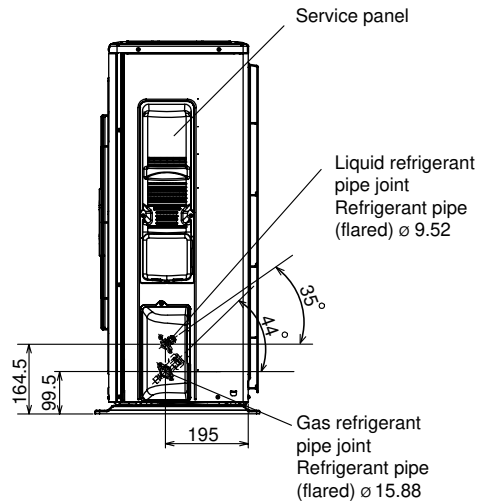
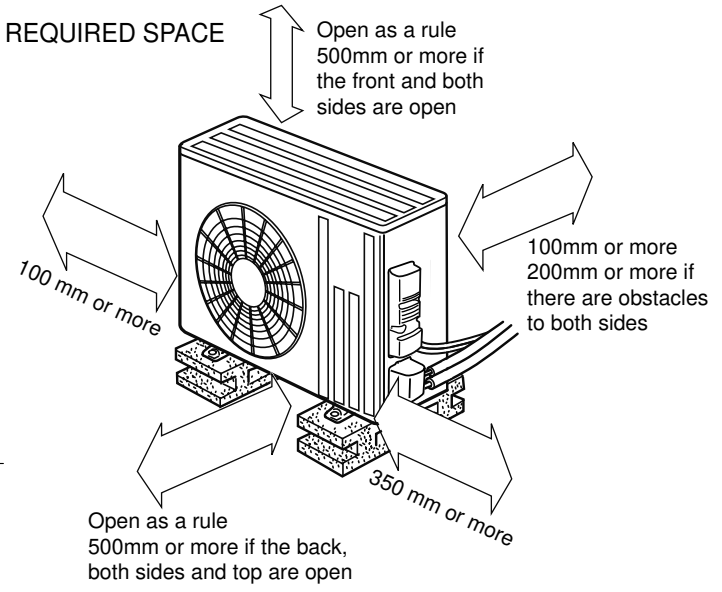
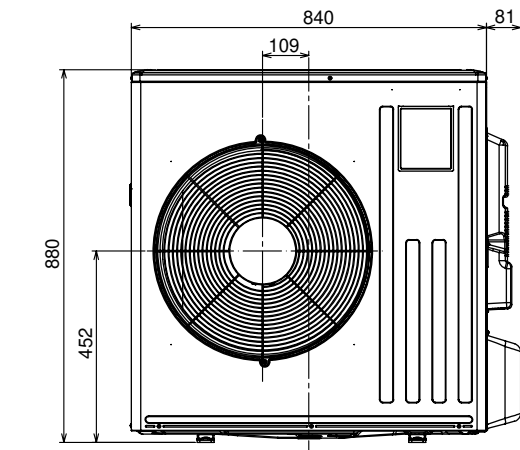
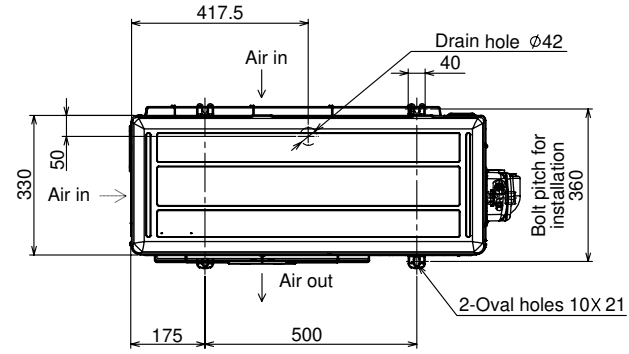

SUZ-KA25VA2.TH  
SUZ-KA35VA2.TH

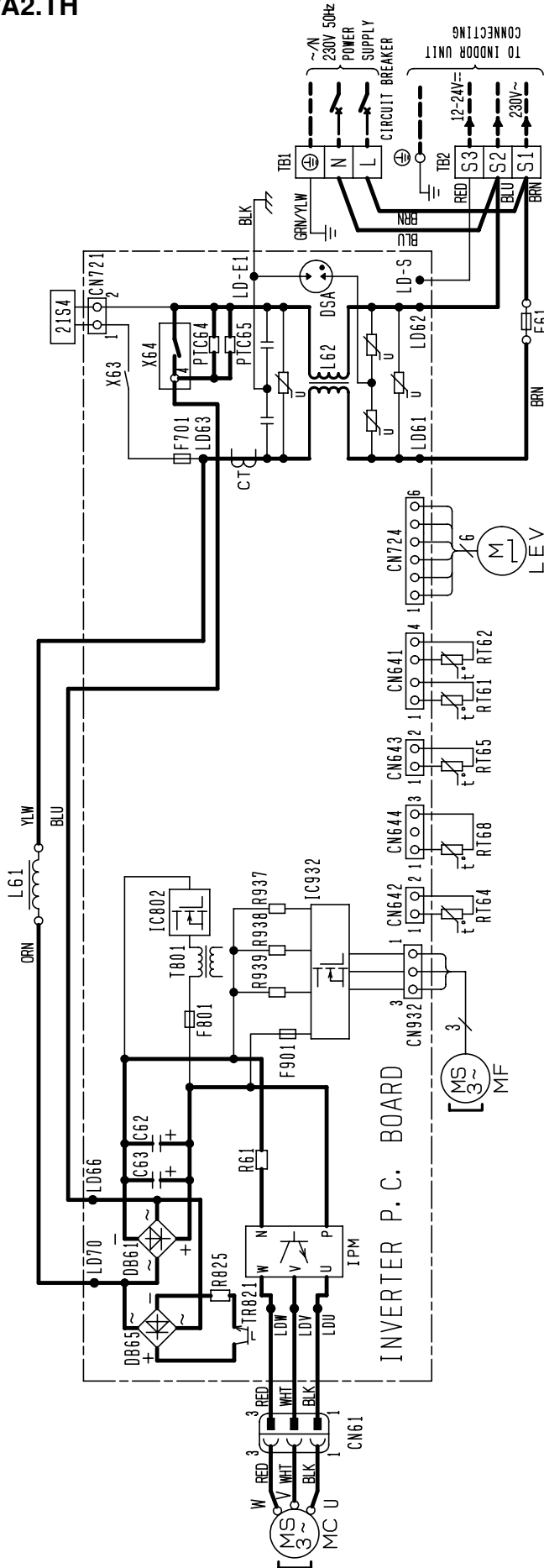

NOTES:1. About the indoor side electric wiring, refer to the indoor unit electric wiring diagram for servicing.  
2. Use copper conductors only. (For field wiring)  
3. Symbols below indicate.  
□ □ □ : Terminal block

| SYMBOL           | NAME                     | SYMBOL       | NAME                                     | SYMBOL     | NAME                       |
|------------------|--------------------------|--------------|--|------------|----------------------------|
| CT               | CURRENT TRANSFORMER      | LEV          | EXPANSION VALVE COIL                     | R61        | CURRENT-DETECTING RESISTOR |
| C62, C63         | SMOOTHING CAPACITOR      | MC           | COMPRESSOR                               | R825, R937 | CURRENT-DETECTING RESISTOR |
| DB61, DB65       | DIODE MODULE             | MF           | FAN MOTOR                                | R938, R939 | CURRENT-DETECTING RESISTOR |
| DSA              | SURGE ABSORBER           | PTC64, PTC65 | CIRCUIT PROTECTION                       | TBL, TB2   | TERMINAL BLOCK             |
| F61              | FUSE (T20AL250V)         | RT61         | DEFROST THERMISTOR                       | TR821      | SWITCHING POWER TRANSISTOR |
| F701, F801, F901 | FUSE (T3.15AL250V)       | RT62         | DISCHARGE TEMP. THERMISTOR               | T801       | TRANSFORMER                |
| IC802            | INTELLIGENT POWER DEVICE | RT64         | FIN TEMP. THERMISTOR                     | X63, X64   | RELAY                      |
| IPM, IC932       | INTELLIGENT POWER MODULE | RT65         | AMBIENT TEMP. THERMISTOR                 | 2154       | REVERSING VALVE COIL       |
| L61              | REACTOR                  | RT68         | OUTDOOR HEAT EXCHANGER TEMP. THERMISTOR. |            |                            |
| L62              | CMC COIL                 |              |  |            |                            |

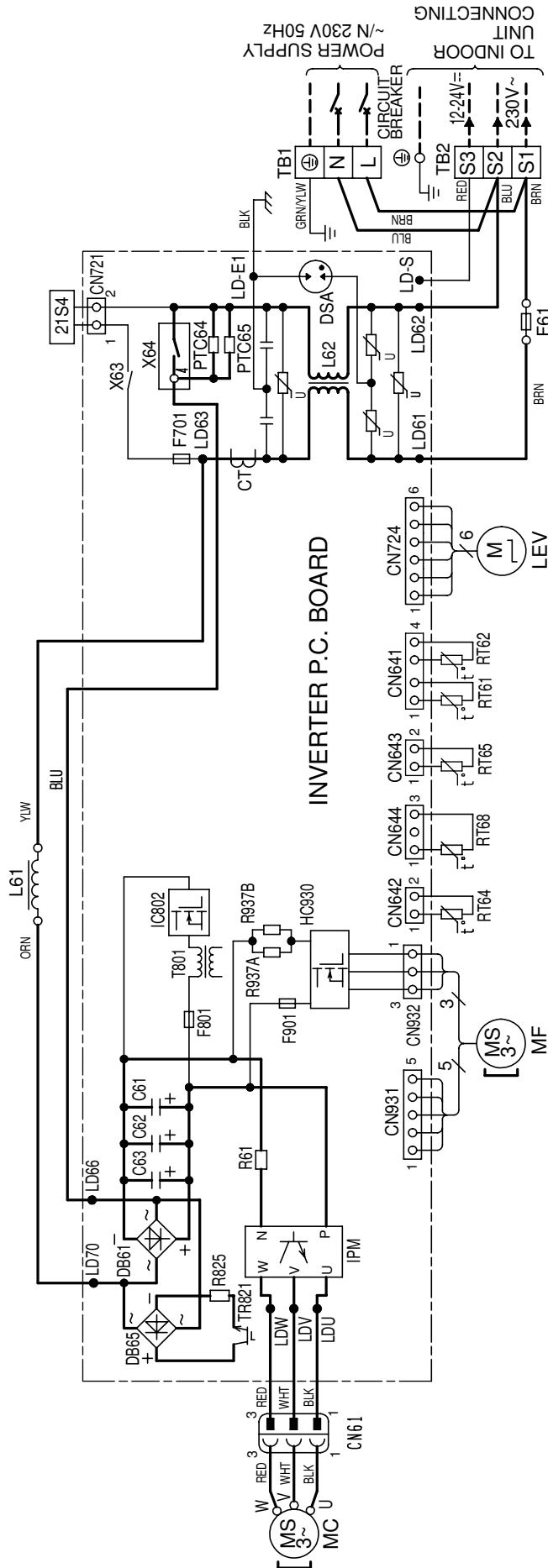

NOTES: 1. About the indoor side electric wiring, refer to the indoor unit electric wiring diagram for servicing.  
 2. Use copper conductors only (for field wiring).  
 3. Symbols below indicate.  
 □□□ : Terminal block

| SYMBOL           | NAME                     | SYMBOL       | NAME                                    | SYMBOL    | NAME                       |
|------------------|--------------------------|--------------|---|-----------|----------------------------|
| CT               | CURRENT TRANSFORMER      | LEV          | EXPANSION VALVE COIL                    | R61       | CURRENT-DETECTING RESISTOR |
| C61,62,63        | SMOOTHING CAPACITOR      | MC           | COMPRESSOR                              | R825      | CURRENT-DETECTING RESISTOR |
| DB61, DB65       | DIODE MODULE             | MF           | FAN MOTOR                               | R937A, B  | CURRENT-DETECTING RESISTOR |
| DSA              | SURGE ABSORBER           | PTC64, PTC65 | CIRCUIT PROTECTION                      | TB1, TB52 | TERMINAL BLOCK             |
| F61              | FUSE (T20AL 250V)        | RT61         | DEFROST THERMISTOR                      | TR821     | SWITCHING POWER TRANSISTOR |
| F701, F801, F901 | FUSE (T3.15AL 250V)      | RT62         | DISCHARGE TEMP. THERMISTOR              | T801      | TRANSFORMER                |
| HC930, IPM       | INTELLIGENT POWER MODULE | RT64         | FIN TEMP. THERMISTOR                    | X63, X64  | RELAY                      |
| IC802            | INTELLIGENT POWER DEVICE | RT65         | AMBIENT TEMP. THERMISTOR                | 21S4      | REVERSING VALVE COIL       |
| L61              | REACTOR                  | RT68         | OUTDOOR HEAT EXCHANGER TEMP. THERMISTOR |           |                            |
| L62              | REACTOR                  |              |   |           |                            |

SUZ-KA60VA2.TH

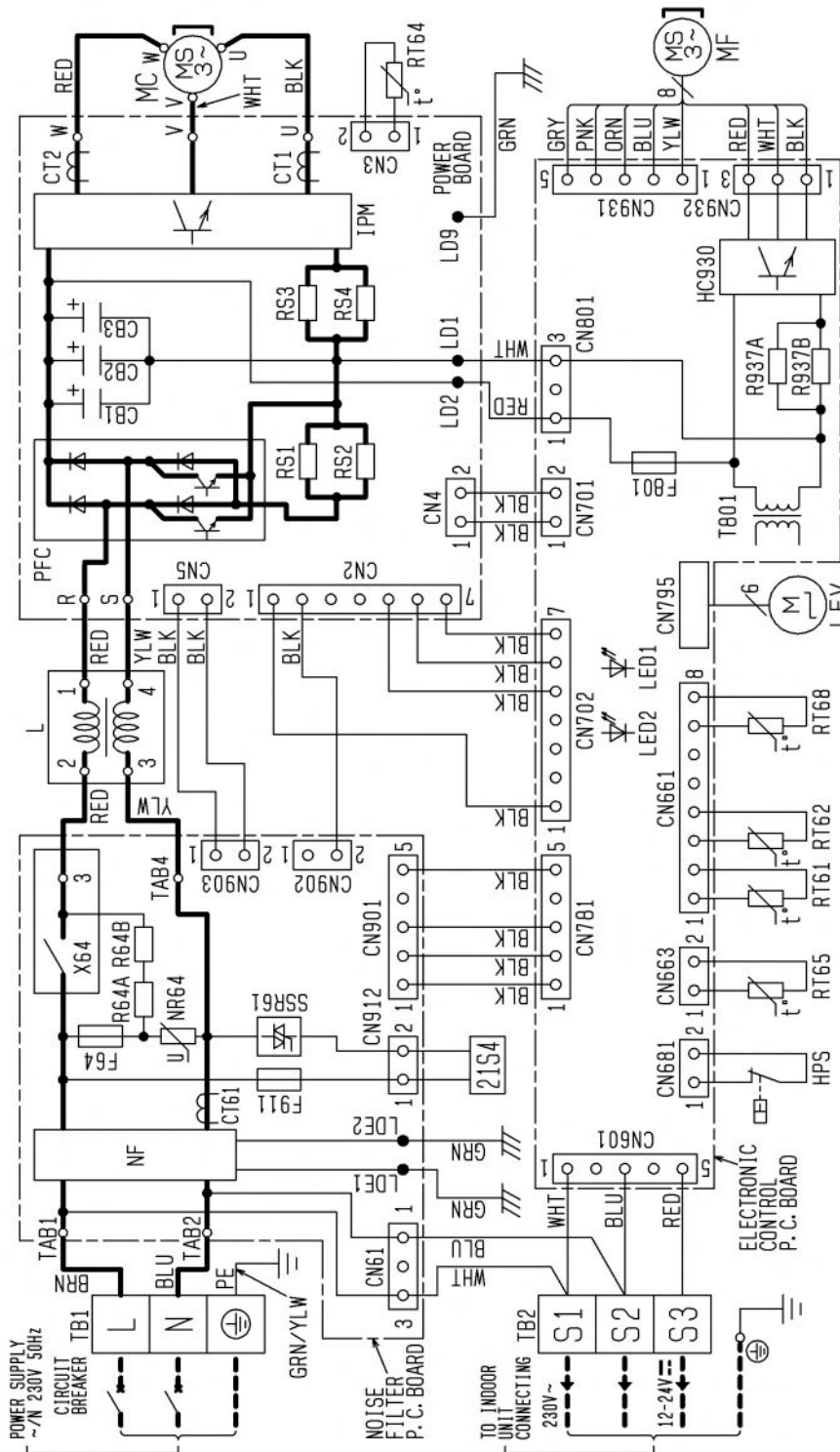

NOTES: 1. About the indoor side electric wiring refer to the indoor unit electric wiring diagram for servicing.  
 2. Use copper conductors only (for field wiring).  
 3. Symbols below indicate.

| SYMBOL | NAME                     | SYMBOL | NAME                       | SYMBOL   | NAME                                    |
|--------|--------------------------|--------|----------------------------|----------|---|
| CB1~3  | SMOOTHING CAPACITOR      | LEV    | EXPANSION VALVE            | RT65     | AMBIENT TEMP. THERMISTOR                |
| CT1.2  | CURRENT TRANSFORMER      | MC     | COMPRESSOR                 | RT68     | OUTDOOR HEAT EXCHANGER TEMP. THERMISTOR |
| CT61   | CURRENT TRANSFORMER      | MF     | FAN MOTOR                  | R64A,B   | RESISTOR                                |
| F64    | FUSE (T2AL 250V)         | NF     | NOISE FILTER               | R937A, B | RESISTOR                                |
| F801   | FUSE (T3.15AL 250V)      | NR64   | VARIABLE RESISTOR          | SSR61    | SOLENOID COIL RELAY                     |
| F911   | FUSE (T1AL 250V)         | PFC    | POWER FACTOR CONTROLLER    | TB1      | TERMINAL BLOCK                          |
| HC930  | INTELLIGENT POWER MODULE | RS1~4  | RESISTOR                   | TB2      | TERMINAL BLOCK                          |
| HPS    | HIGH PRESSURE SWITCH     | RT61   | DEFROST THERMISTOR         | T801     | TRANSFORMER                             |
| IPM    | INTELLIGENT POWER MODULE | RT62   | DISCHARGE TEMP. THERMISTOR | X64      | RELAY                                   |
| L      | REACTOR                  | RT64   | FIN TEMP. THERMISTOR       | 21S4     | REVERSING VALVE COIL                    |

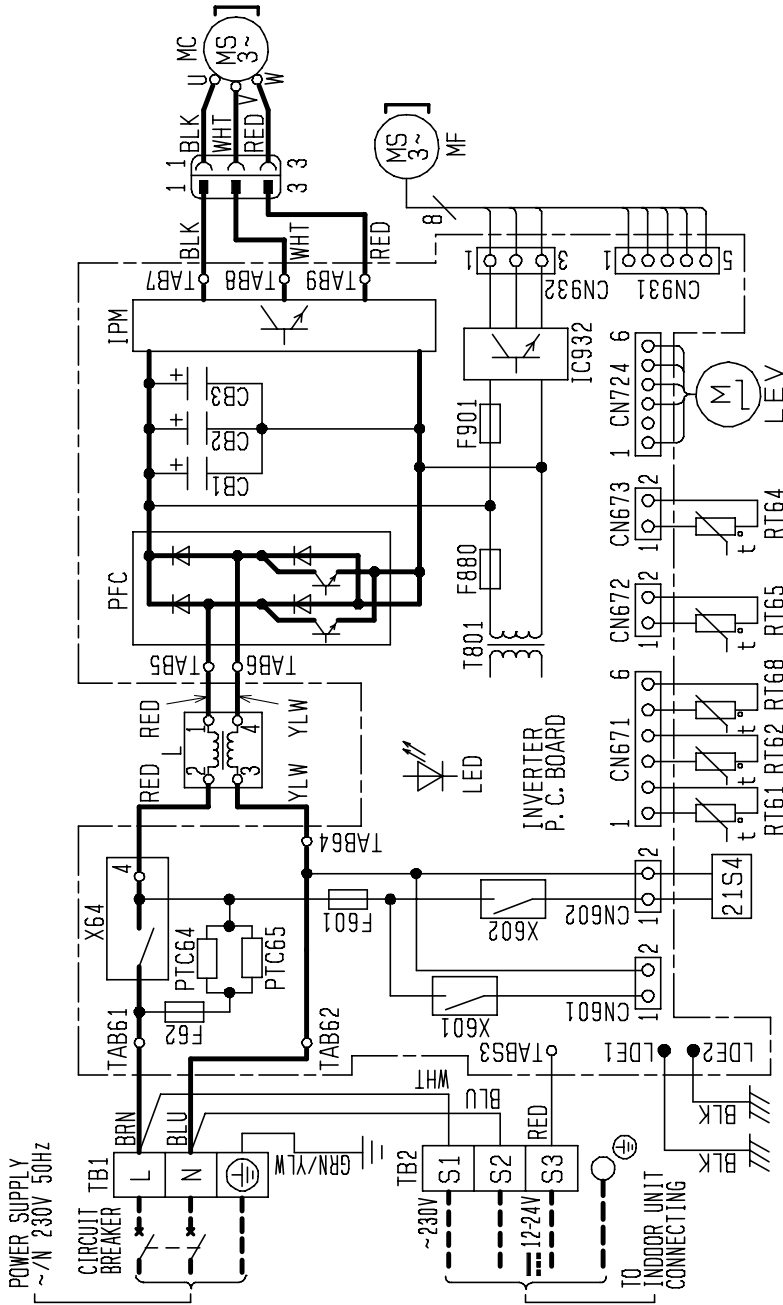

NOTES  
 1. About the indoor side electric wiring, refer to the indoor unit electric wiring diagram for servicing.  
 2. Use copper conductors only for field wiring.  
 3. Symbols indicate: : terminal block

| SYMBOL | NAME                     | SYMBOL   | NAME                                    |
|--------|--------------------------|----------|---|
| CBL1~3 | SMOOTHING CAPACITOR      | PTC65    | CIRCUIT PROTECTION                      |
| F601   | FUSE (T3.15A/250V)       | RT61     | DEFROST THERMISTOR                      |
| F62    | FUSE (T2A/250V)          | RT62     | DISCHARGE TEMP. THERMISTOR              |
| F880   | FUSE (T3.15A/250V)       | RT64     | FIN TEMP. THERMISTOR                    |
| F901   | FUSE (T3.15A/250V)       | RT65     | AMBIENT TEMP. THERMISTOR                |
| IC932  | INTELLIGENT POWER MODULE | RT68     | OUTDOOR HEAT EXCHANGER TEMP. THERMISTOR |
| IPM    | INTELLIGENT POWER MODULE | TB1, TB2 | TERMINAL BLOCK                          |
| L      | REACTOR                  | T801     | TRANSFORMER                             |
| LEV    | EXPANSION VALVE COIL     | X601     | RELAY                                   |
| MC     | COMPRESSOR               | X602     | RELAY                                   |
| MF     | FAN MOTOR                | X64      | RELAY                                   |
| PFC    | POWER FACTOR CONTROLLER  | 21S4     | CIRCUIT PROTECTION                      |
| PTC64  | CIRCUIT PROTECTION       |          | REVERSING VALVE SOLENOID COIL           |

SUZ-KA25VA2.TH

Unit: mm

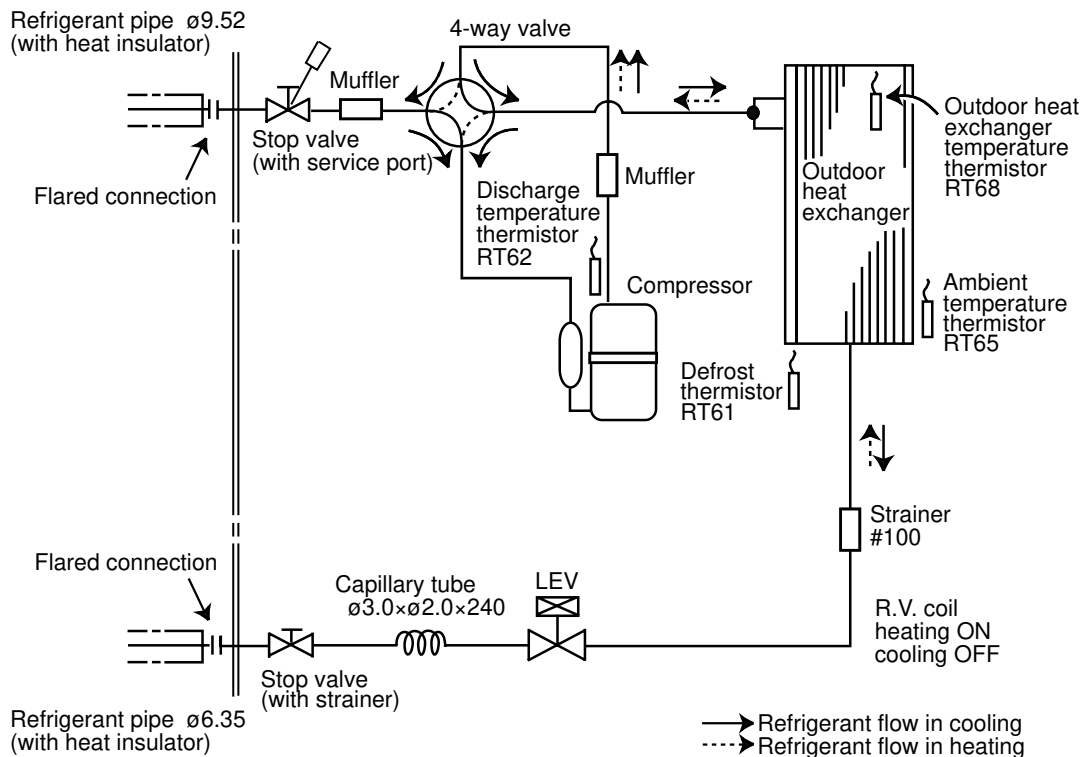

Unit: mm

SUZ-KA35VA2.TH

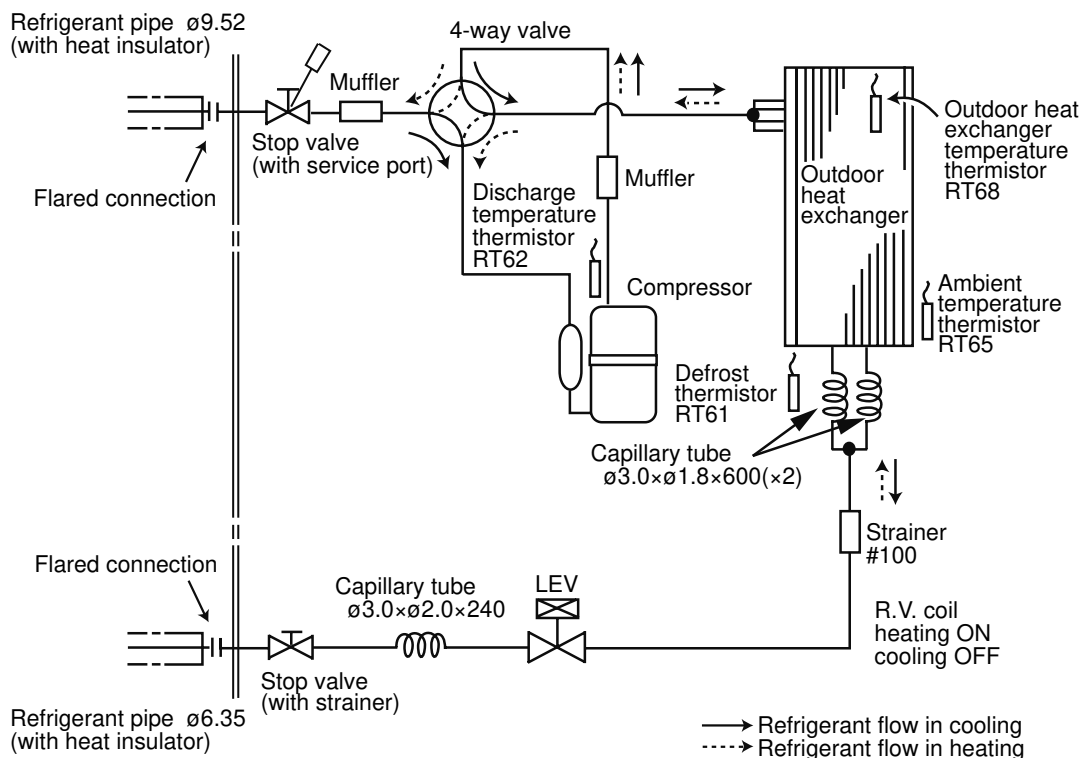

**SUZ-KA50VA2.TH**

Unit: mm

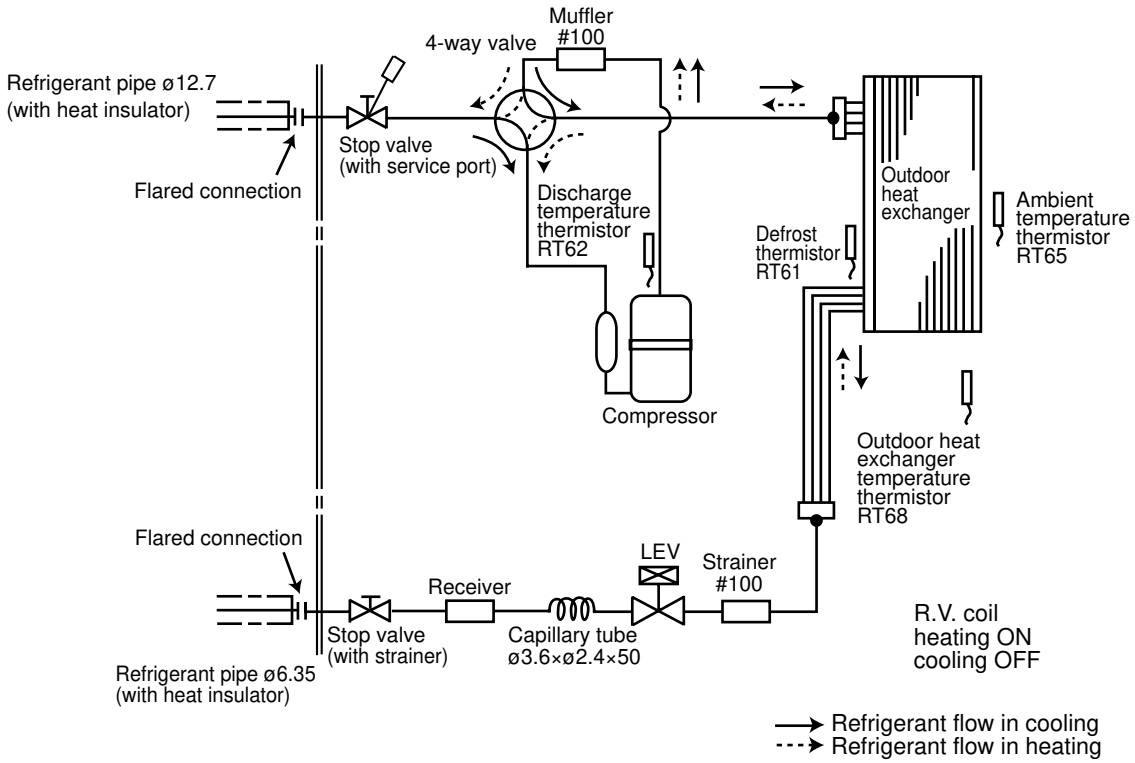

**SUZ-KA60VA2.TH**

Unit: mm

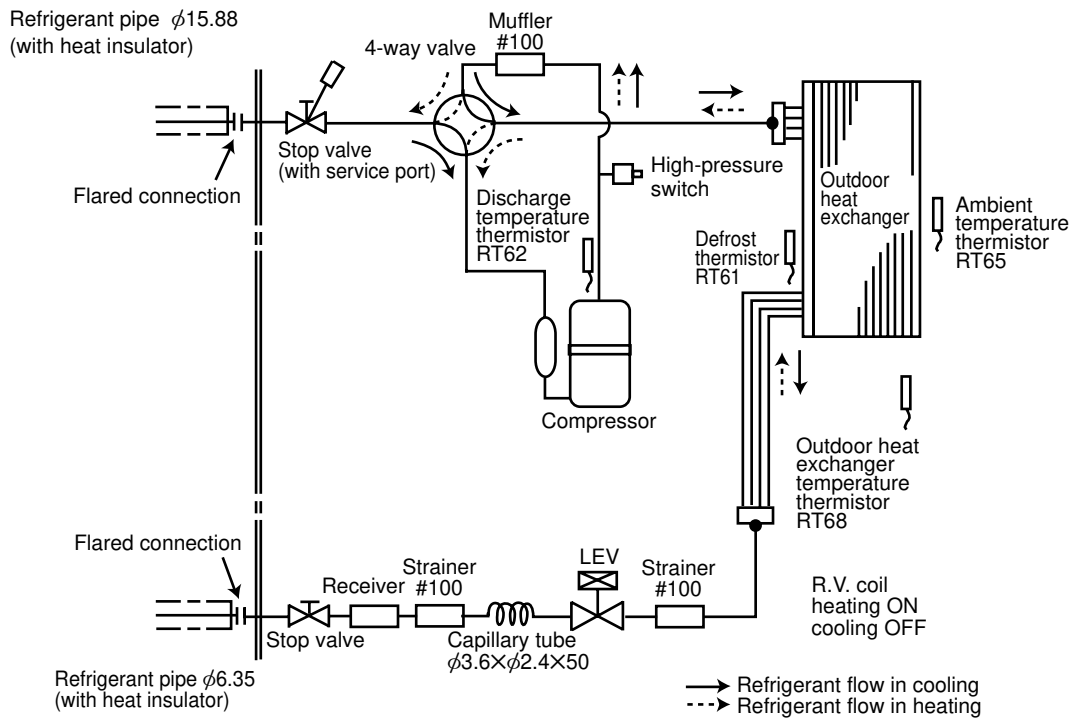

SUZ-KA71VA2.TH

Unit: mm

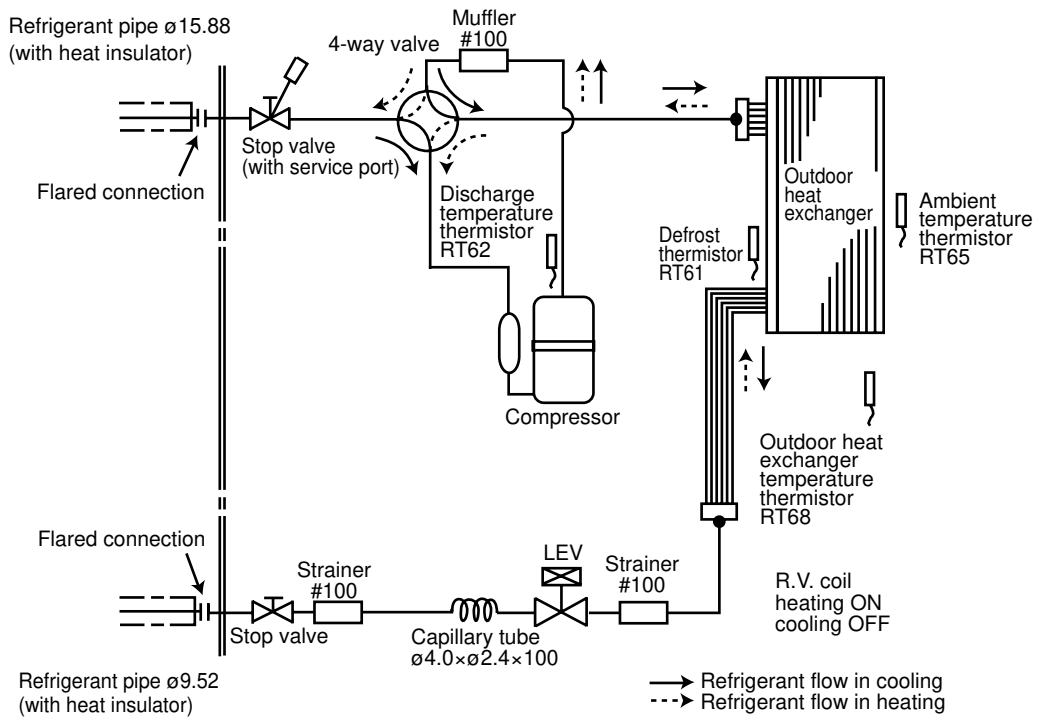

SUZ-KA25VA2.TH SUZ-KA35VA2.TH SUZ-KA50VA2.TH  
 SUZ-KA60VA2.TH SUZ-KA71VA2.TH

### MAX. REFRIGERANT PIPING LENGTH

| Models         | Refrigerant piping: m |                          | Piping size O.D: mm |        |
|----------------|-----------------------|--------------------------|---------------------|--------|
|                | Max. Length A         | Max. Height difference B | Gas                 | Liquid |
| SUZ-KA25VA2.TH | 20                    | 12                       | 9.52                | 6.35   |
| SUZ-KA35VA2.TH |                       |                          |                     |        |
| SUZ-KA50VA2.TH | 30                    | 30(15)                   | 12.7                | 9.52   |
| SUZ-KA60VA2.TH |                       |                          |                     |        |
| SUZ-KA71VA2.TH |                       |                          |                     |        |

( ): MFZ-KA50VA-E4

### MAX. HEIGHT DIFFERENCE

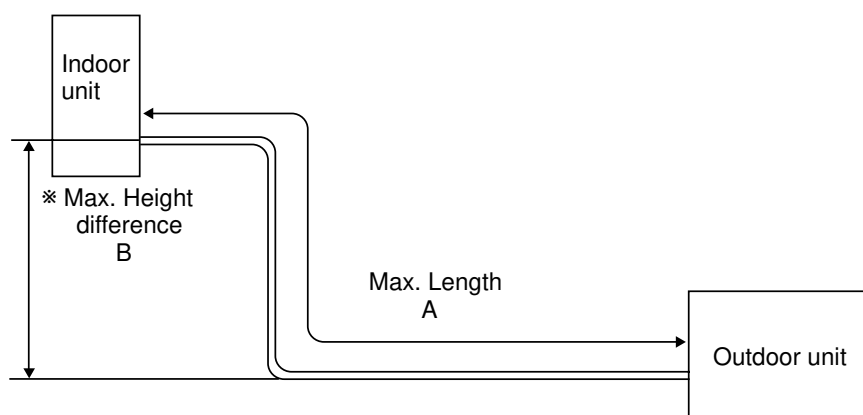

\* Height difference limitations are binding regardless of which unit, indoor or outdoor, is position high.

### ADDITIONAL REFRIGERANT CHARGE (R410A: g)

| Models         | Outdoor unit precharged | Refrigerant piping length (one way) |    |    |    |     |     |     |     |     |     |     |     |
|----------------|-------------------------|-------------------------------------|----|----|----|-----|-----|-----|-----|-----|-----|-----|-----|
|                |                         | 5m                                  | 6m | 7m | 8m | 9m  | 10m | 11m | 12m | 13m | 14m | 15m | 20m |
| SUZ-KA25VA2.TH | 800                     | 0                                   | 0  | 0  | 90 | 120 | 150 | 180 | 210 | 240 | 270 | 300 | 450 |
| SUZ-KA35VA2.TH | 1,050                   | 0                                   | 0  | 0  | 90 | 120 | 150 | 180 | 210 | 240 | 270 | 300 | 450 |

Calculation:  $Xg=30g/m \times (\text{Refrigerant piping length}(m)-5)$

| Models         | Outdoor unit precharged | Refrigerant piping length (one way) |     |     |     |     |     |
|----------------|-------------------------|-------------------------------------|-----|-----|-----|-----|-----|
|                |                         | 7m                                  | 10m | 15m | 20m | 25m | 30m |
| SUZ-KA50VA2.TH | 1,600                   | 0                                   | 60  | 160 | 260 | 360 | 460 |
| SUZ-KA60VA2.TH | 1,800                   | 0                                   | 60  | 160 | 260 | 360 | 460 |

Calculation :  $Xg=20g/m \times (\text{Refrigerant piping length}(m)-7)$

| Models         | Outdoor unit precharged | Refrigerant piping length (one way) |     |     |     |     |       |
|----------------|-------------------------|-------------------------------------|-----|-----|-----|-----|-------|
|                |                         | 7m                                  | 10m | 15m | 20m | 25m | 30m   |
| SUZ-KA71VA2.TH | 1,800                   | 0                                   | 165 | 440 | 715 | 990 | 1,265 |

Calculation :  $Xg=55g/m \times (\text{Refrigerant piping length}(m)-7)$

SUZ-KA25VA2.TH  
SUZ-KA60VA2.TH

SUZ-KA35VA2.TH  
SUZ-KA71VA2.TH

SUZ-KA50VA2.TH

**9-1. Outdoor fan motor control**

The fan motor turns ON/OFF, interlocking with the compressor.

[ON] The fan motor turns ON 5 seconds before the compressor starts up.

[OFF] The fan motor turns OFF 15 seconds after the compressor has stopped running.

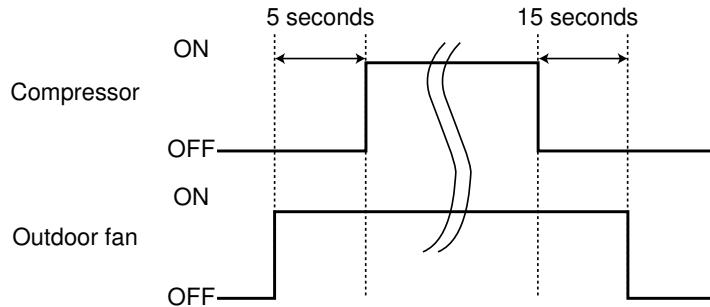

**9-2. R.V. coil control**

Heating ..... ON  
Cooling ..... OFF  
Dry ..... OFF

**NOTE:** The 4-way valve reverses for 5 seconds right before start-up of the compressor.

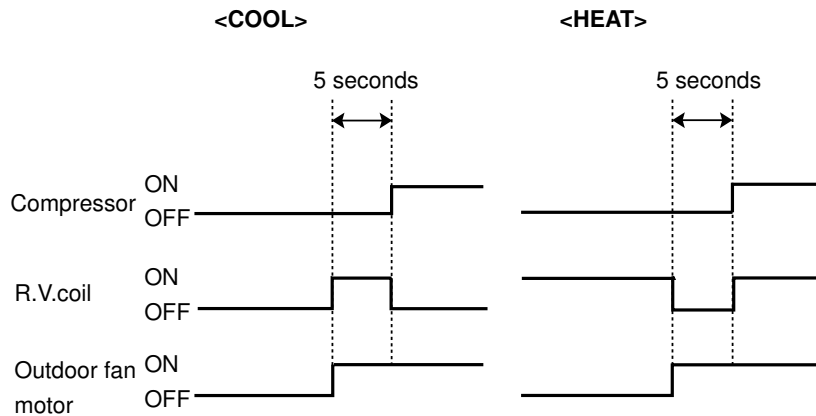

**9-3. Relation between main sensor and actuator**

| Sensor                             | Purpose                                    | Actuator   |     |                   |          |
|------------------------------------|--|------------|-----|-------------------|----------|
|                                    |  | Compressor | LEV | Outdoor fan motor | R.V.coil |
| Discharge temperature thermistor   | Protection                                 | ○          | ○   |                   |          |
| Indoor coil temperature thermistor | Cooling: Coil frost prevention             | ○          |     |                   |          |
|                                    | Heating: High pressure protection          | ○          | ○   |                   |          |
| Defrost thermistor                 | Heating: Defrosting                        | ○          | ○   | ○                 | ○        |
| Fin temperature thermistor         | Protection                                 | ○          |     | ○                 |          |
| Ambient temperature thermistor     | Cooling: Low ambient temperature operation | ○          | ○   | ○                 |          |
|                                    | Heating: High pressure protection          | ○          | ○   | ○                 |          |

## SUZ-KA25VA2.TH SUZ-KA35VA2.TH

## CHANGE IN DEFROST SETTING

<JS> When the JS wire of the outdoor Inverter P.C. board is cut/ soldered, the defrost finish temperature is changed.  
(Refer to 11-6-1)

| Jumper wire |                               | Defrost finish temperature |                |
|-------------|-------------------------------|----------------------------|----------------|
|             |                               | SUZ-KA25VA2.TH             | SUZ-KA35VA2.TH |
| JS          | soldered<br>(Initial setting) | 5°C                        | 10°C           |
|             | none<br>(cut)                 | 8°C                        | 13°C           |

SUZ-KA25VA2.TH  
SUZ-KA50VA2.THSUZ-KA35VA2.TH  
SUZ-KA60VA2.TH

SUZ-KA71VA2.TH

## 11-1. Cautions on troubleshooting

## 1. Before troubleshooting, check the following:

- 1) Check the power supply voltage.
- 2) Check the indoor/outdoor connecting wire for miswiring.

## 2. Take care the following during servicing.

- 1) Before servicing the air conditioner, be sure to turn OFF the main unit first with the remote controller, and turn off the breaker.
- 2) Be sure to turn OFF the power supply before removing the front panel, the cabinet, the top panel, and the electronic control P.C. board.
- 3) When removing the electrical parts, be careful of the residual voltage of smoothing capacitor.
- 4) When removing the electronic control P.C. board, hold the edge of the board with care NOT to apply stress on the components.
- 5) When connecting or disconnecting the connectors, hold the housing of the connector. DO NOT pull the lead wires.

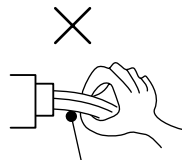

Lead wire

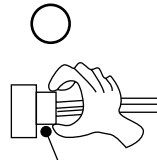

Housing point

## 3. Troubleshooting procedure

- 1) First, check if the OPERATION INDICATOR lamp is blinking on and off to indicate an abnormality. To make sure, check how many times the abnormality indication is blinking on and off before starting service work.
- 2) Before servicing check that the connector and terminal are connected properly.
- 3) If the electronic control P.C. board is supposed to be defective, check the copper foil pattern for disconnection and the components for bursting and discoloration.
- 4) When troubleshooting, refer to 11-2. and 11-3.

## 11-2. Failure mode recall function

As this air conditioner has a function to memorize all the failures that had happened, the latest failure detail can be recalled by following the procedures below.

Use this function when the check code is not displayed with wired remote controller or the remote controller at use is wireless type.

### 11-2-1. Flow chart of the indoor/outdoor unit failure mode recall function

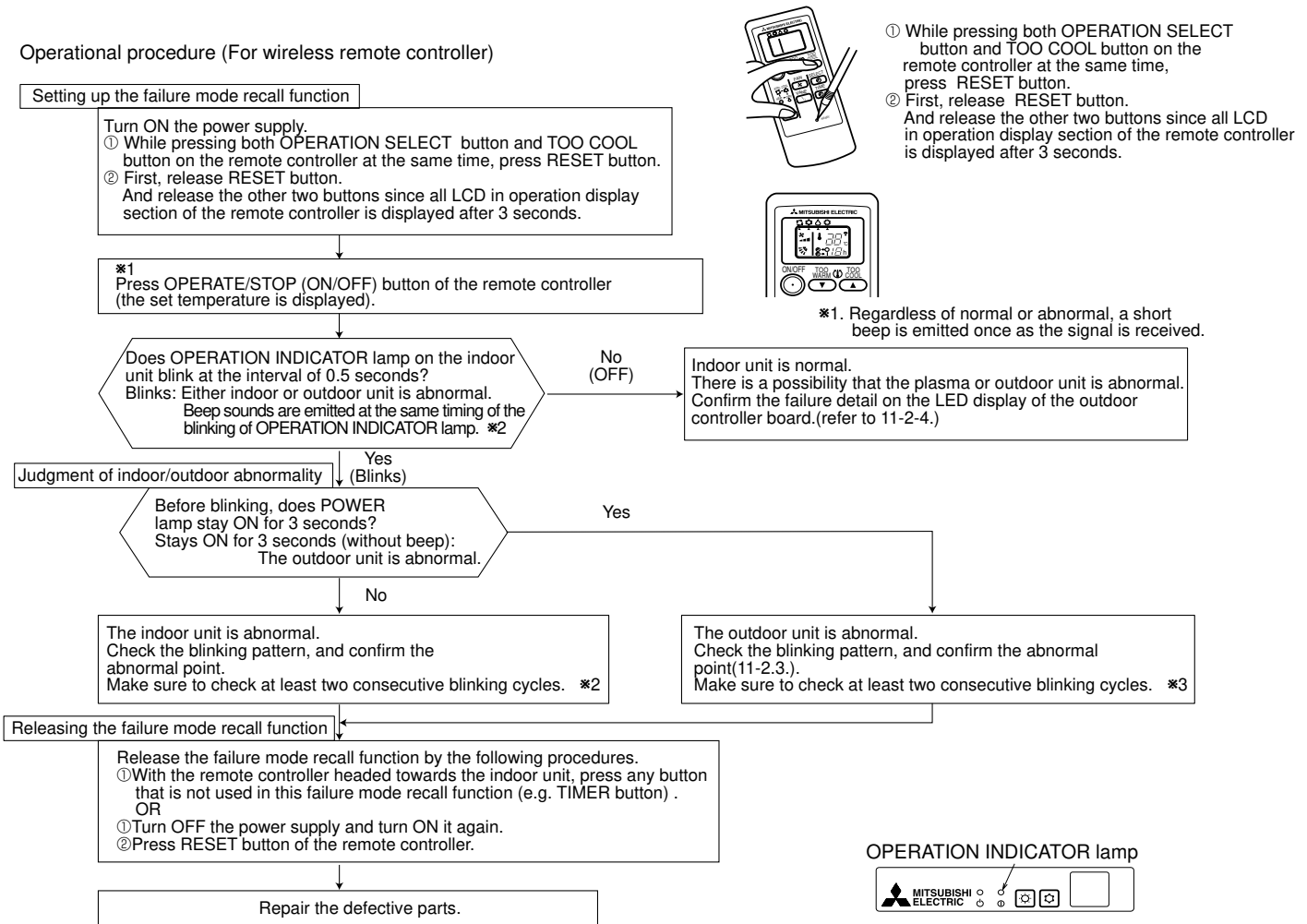

Note1. Make sure to release the failure mode recall function once it is set up, otherwise the unit cannot operate properly.  
 2. If the abnormal condition is not deleted from the memory, the last abnormal condition is kept memorized.

#### ※2. Blinking pattern when the indoor unit is abnormal:[Output pattern A]

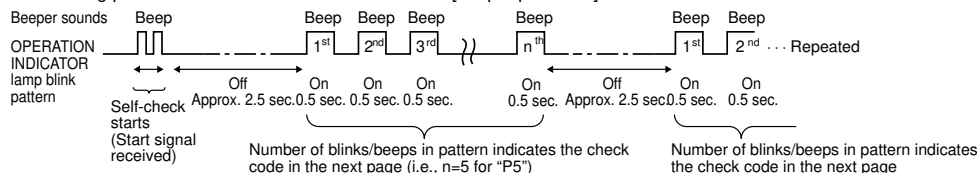

#### ※3. Blinking pattern when the outdoor unit is abnormal:[Output pattern B]

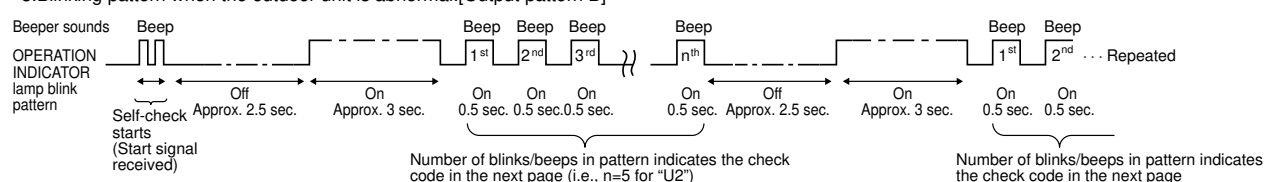



## 11-2-4. Outdoor unit failure mode table

### SUZ-KA25VA2.TH SUZ-KA35VA2.TH SUZ-KA50VA2.TH

| Abnormal point<br>(Failure mode/protection)                                    | LED indication<br>(Outdoor P.C. board) | Condition  | Correspondence   |
|--|--|--|--|
| None (Normal)  | —                                      | —  | —  |
| Outdoor power system   | —                                      | Overcurrent protection stop is continuously performed 3 times within 1 minute after the compressor gets started.   | <ul style="list-style-type: none"> <li>•Reconnect connectors.</li> <li>•Refer to 11-5. ㉔ "How to check inverter/compressor".</li> <li>•Check stop valve.</li> </ul>                          |
| Discharge temperature thermistor   | 1-time flash every 2.5 seconds         | Thermistor shorts or opens during compressor running.  | <ul style="list-style-type: none"> <li>•Refer to 11-5. ㉔ "Check of outdoor thermistors". Defective outdoor thermistors can be identified by checking the blinking pattern of LED.</li> </ul> |
| Defrost thermistor   |  |  |  |
| Fin temperature thermistor   | 3-time flash<br>2.5 seconds OFF        |  |  |
| P.C. board temperature thermistor  | 4-time flash<br>2.5 seconds OFF        |  |  |
| Ambient temperature thermistor   | 2-time flash<br>2.5 seconds OFF        |  |  |
| Overcurrent  | 11-time flash<br>2.5 seconds OFF       | Large current flows into intelligent power module.   | <ul style="list-style-type: none"> <li>•Reconnect compressor connector.</li> <li>•Refer to 11-5. ㉔ "How to check inverter/compressor".</li> <li>•Check stop valve.</li> </ul>                |
| Compressor synchronous abnormality<br>(Compressor start-up failure protection) | 12-time flash<br>2.5 seconds OFF       | Waveform of compressor current is distorted.   | <ul style="list-style-type: none"> <li>•Reconnect compressor connector.</li> <li>•Refer to 11-5. ㉔ "How to check inverter/compressor".</li> </ul>  |
| Discharge temperature  | —                                      | Temperature of discharge temperature thermistor exceeds 116°C, compressor stops. Compressor can restart if discharge temperature thermistor reads 100°C or less 3 minutes later.   | <ul style="list-style-type: none"> <li>•Check refrigerant circuit and refrigerant amount.</li> <li>•Refer to 11-5. ㉔ "Check of LEV".</li> </ul>  |
| High pressure  | —                                      | Temperature indoor coil thermistor exceeds 70°C in HEAT mode. Temperature defrost thermistor exceeds 70°C in COOL mode.  | <ul style="list-style-type: none"> <li>•Check refrigerant circuit and refrigerant amount.</li> <li>•Check stop valve.</li> </ul>   |
| Fin temperature/P.C. board temperature   | 7-time flash<br>2.5 seconds OFF        | Temperature of fin temperature thermistor on the inverter P.C. board exceeds 75 ~ 80°C, or temperature of P.C. board temperature thermistor on the inverter P.C. board exceeds 70 ~ 75°C.  | <ul style="list-style-type: none"> <li>•Check around outdoor unit.</li> <li>•Check outdoor unit air passage.</li> <li>•Refer to 11-5. ㉔ "Check of outdoor fan motor".</li> </ul>             |
| Outdoor fan motor  | —                                      | Outdoor fan has stopped 3 times in a row within 30 seconds after outdoor fan start-up.   | <ul style="list-style-type: none"> <li>•Refer to 11-5. ㉔ "Check of outdoor fan motor".</li> <li>•Refer to 11-5. ㉔ "Check of inverter P.C. board".</li> </ul>                                 |
| Nonvolatile memory data  | 5-time flash<br>2.5 seconds OFF        | Nonvolatile memory data cannot be read properly.   | <ul style="list-style-type: none"> <li>•Replace the inverter P.C. board.</li> </ul>  |
| Discharge temperature  | —                                      | Temperature of discharge temperature thermistor has been 50°C or less for 20 minutes.  | <ul style="list-style-type: none"> <li>•Refer to 11-5. ㉔ "Check of LEV".</li> <li>•Check refrigerant circuit and refrigerant amount.</li> </ul>  |
| DC voltage   | 8-time flash<br>2.5 seconds OFF        | DC voltage of inverter cannot be detected normally.  | <ul style="list-style-type: none"> <li>•Refer to 11-5. ㉔ "How to check inverter/compressor".</li> </ul>  |
| Each phase current of compressor   | 9-time flash<br>2.5 seconds OFF        | Each phase current of compressor cannot be detected normally.  |  |
| Overcurrent Compressor open-phase  | 10-time flash<br>2.5 seconds OFF       | Large current flows into intelligent power module (IPM). The open-phase operation of compressor is detected. The interphase short out occurs in the output of the intelligent power module (IPM). The compressor winding shorts out. | <ul style="list-style-type: none"> <li>•Reconnect compressor connector.</li> <li>•Refer to 11-5. ㉔ "How to check inverter/compressor".</li> </ul>  |
| Stop valve (Closed valve)  | 14-time flash<br>2.5 seconds OFF       | Closed valve is detected by compressor current.  | <ul style="list-style-type: none"> <li>•Check stop valve.</li> </ul>   |

**NOTE:** Blinking patterns of this mode differ from the ones of Troubleshooting check table (11-3.).

## SUZ-KA60VA2.TH

| Outdoor LED indication                  |   | Abnormal point<br>(Failure mode)   | Details of abnormal  | Detecting method  | Check point   |  |  |
|---|---|--|--|---|---|--|--|
| LED1                                    | LED2  |  |  |   |   |  |  |
| Lighting                                | Once  | Outdoor thermistors  | Discharge temperature thermistor   | When a short circuit is detected in the thermistor during operation, or when an open circuit is detected in the thermistor after 10 minutes of compressor start-up.   | <ul style="list-style-type: none"> <li>• Check the outdoor thermistors.</li> </ul>  |  |  |
|   |   |  | Defrost thermistor   | When a short circuit is detected in the thermistor during operation, or when an open circuit is detected in the thermistor after 5 minutes of compressor start-up.  |   |  |  |
|   |   |  | Ambient temperature thermistor   | When a short or open circuit is detected in the thermistor during operation.  |   |  |  |
|   |   |  | Fin temperature thermistor   |   |   |  |  |
|   |   |  | P.C. board temperature thermistor  |   |   |  |  |
|   | Twice   | Outdoor heat exchanger temperature thermistor  | Outdoor heat exchanger temperature thermistor  | When a short circuit is detected in the thermistor during operation, or when an open circuit is detected in the thermistor after 5 minutes (in cooling) and 10 minutes (in heating) of compressor start-up. | <ul style="list-style-type: none"> <li>• Replace the outdoor electronic control P.C. board.</li> <li>• Check the outdoor thermistors.</li> </ul>  |  |  |
|   | 3 times   |  | Outdoor control system   | EEPROM  | When nonvolatile memory data cannot be read properly, unit stops.   | <ul style="list-style-type: none"> <li>• Replace the outdoor electronic control P.C. board.</li> </ul>                                 |  |
|   | 4 times   |  |  | Converter control system  | Communication error between P.C. boards   | When the communication between boards protection stop is continuously performed twice.   | <ul style="list-style-type: none"> <li>• Check the connecting wire between outdoor electronic control P.C. board and power board.</li> </ul> |
|   | 9 times   |  |  |   | Communication between P.C. boards protection  | Communication error occurs between the electronic control P.C.board and power board for more than 10 seconds.                          |  |
|   |   | 5 times  | Goes out   | Current sensor  | Current sensor protection stop is continuously performed twice.   | <ul style="list-style-type: none"> <li>• Replace the power board.</li> </ul>   |  |
| Current sensor protection               | When a short or open circuit is detected in the current sensor during compressor operating. |  |  |   |   |  |  |
| Zero cross detecting circuit            | The protection stop of the zero cross detecting circuit is continuously performed 10 times. |  |  | <ul style="list-style-type: none"> <li>• Check the connecting wire among electronic control P.C. board, noise filter P.C. board and power board.</li> </ul>   |   |  |  |
| Zero cross detecting circuit protection | When zero cross signal cannot be detected while the compressor is operating.                |  |  |   |   |  |  |
| 6 times                                 | Goes out  | Converter protection   | Converter protection   | When a failure is detected in the operation of the converter during operation.  | <ul style="list-style-type: none"> <li>• Replace the power board.</li> </ul>  |  |  |
|   |   |  | Bus-bar voltage protection (1)   | When the bus-bar voltage exceeds 400V or falls to 200V or below during compressor operating.  |   |  |  |
|   |   |  | Bus-bar voltage protection (2)<br>*Even if this protection stop is performed continuously 3 times, it does not mean the abnormality in outdoor power system.                                     | When the bus-bar voltage exceeds 400V or falls to 50V or below during compressor operating.   |   |  |  |
| Once                                    | Goes out  | Overcurrent protection   | IPM protection   | When overcurrent is detected after 30 seconds of compressor start-up.   | <ul style="list-style-type: none"> <li>• Check the connection of the compressor connecting wire.</li> <li>• Check the inverter/ compressor.</li> <li>• Check the stop valve.</li> </ul> |  |  |
|   |   |  | Lock protection  | When overcurrent is detected within 30 seconds after the compressor gets started.   |   |  |  |
| 3 times                                 | Goes out  | Fin temperature/P.C. board temperature overheat  | Fin temperature overheat protection  | When the fin temperature exceeds 87°C during operation.   | <ul style="list-style-type: none"> <li>• Check around outdoor unit.</li> <li>• Check outdoor unit air passage.</li> <li>• Check the outdoor fan motor.</li> </ul>                       |  |  |
| 4 times                                 | Goes out  |  | P.C. board temperature overheat protection   | When the P.C. board temperature exceeds 70°C during operation.  |   |  |  |
| Lighting                                | Lighting  | Refrigerant system   | Discharge temperature overheat protection  | When discharge temperature exceeds 116°C.   | <ul style="list-style-type: none"> <li>• Check refrigerant circuit and refrigerant amount.</li> <li>• Check the LEV.</li> <li>• Check the outdoor thermistors.</li> </ul>               |  |  |
|   |   | High pressure protection   | HPS protection   | When high-pressure is detected with the high-pressure switch (HPS) during operation.  |   | <ul style="list-style-type: none"> <li>• Check refrigerant circuit and refrigerant amount.</li> <li>• Check the stop valve.</li> </ul> |  |
|   |   |  | High pressure protection (Overheat protection)   | When the indoor coil thermistor (TH5) exceeds 70°C in HEAT mode.<br>When the outdoor heat exchanger thermistor exceeds 70°C in COOL mode.   |   |  |  |
|   |   | Low discharge temperature  | Low discharge temperature protection   | When the frequency of the compressor is kept 80Hz or more and discharge temperature is kept under 39°C for more than 20 minutes.  |   | <ul style="list-style-type: none"> <li>• Check refrigerant circuit and refrigerant amount.</li> <li>• Check the LEV.</li> </ul>        |  |
|   |   | Outdoor fan  | Outdoor fan protection   | When outdoor fan has stopped within 30 seconds 3 times in a row after outdoor fan start -up,unit stops.   |   | <ul style="list-style-type: none"> <li>• Check the outdoor fan motor.</li> </ul>   |  |
| Outdoor power system                    | Outdoor power system  | When IPM protection stop or lock protection stop is continuously performed 3 times within 1 minute after the compressor get started, or when converter protection stop or bus-bar voltage protection stop is continuously performed 3 times within 3 minutes after start-up. | <ul style="list-style-type: none"> <li>• Reconnect compressor connector.</li> <li>• Check the inverter/ compressor.</li> <li>• Check the stop valve.</li> <li>• Check the PAM module.</li> </ul> |   |   |  |  |

NOTE: Blinking patterns of this mode differ from the ones of Troubleshooting check table (11-3).

## SUZ-KA71VA2.TH

| Abnormal point<br>(Failure mode / protection)                                  | LED indication<br>(Outdoor P.C. board) | Condition  | Correspondence   |                                 |
|--|--|--|--|---------------------------------|
| None (Normal)  | —                                      | —  | —  |                                 |
| Outdoor power system   | —                                      | Overcurrent protection stop is continuously performed 3 times within 1 minute after the compressor gets started.   | <ul style="list-style-type: none"> <li>•Reconnect connectors.</li> <li>•Refer to 11-5. ③ "How to check inverter/compressor".</li> <li>•Check stop valve.</li> </ul>                          |                                 |
| Discharge temperature thermistor   | 1-time flash every 2.5 seconds         | Thermistor shorts or opens during compressor running.  | <ul style="list-style-type: none"> <li>•Refer to 11-5. ③ "Check of outdoor thermistors". Defective outdoor thermistors can be identified by checking the blinking pattern of LED.</li> </ul> |                                 |
| Defrost thermistor   |  |  |  |                                 |
| Fin temperature thermistor   |  |  |  | 3-time flash<br>2.5 seconds OFF |
| P.C. board temperature thermistor  |  |  |  | 4-time flash<br>2.5 seconds OFF |
| Ambient temperature thermistor   |  |  |  | 2-time flash<br>2.5 seconds OFF |
| Outdoor heat exchanger temperature thermistor                                  | —                                      |  |  |                                 |
| Overcurrent  | 11-time flash<br>2.5 seconds OFF       | Large current flows into intelligent power module.   | <ul style="list-style-type: none"> <li>•Reconnect compressor connector.</li> <li>•Refer to 11-5. ③ "How to check inverter/compressor".</li> <li>•Check stop valve.</li> </ul>                |                                 |
| Compressor synchronous abnormality<br>(Compressor start-up failure protection) | 12-time flash<br>2.5 seconds OFF       | Waveform of compressor current is distorted.   | <ul style="list-style-type: none"> <li>•Reconnect compressor connector.</li> <li>•Refer to 11-5. ③ "How to check inverter/compressor".</li> </ul>  |                                 |
| Discharge temperature  | —                                      | Temperature of discharge temperature thermistor exceeds 116°C, compressor stops. Compressor can restart if discharge temperature thermistor reads 100°C or less 3 minutes later.   | <ul style="list-style-type: none"> <li>•Check refrigerant circuit and refrigerant amount.</li> <li>•Refer to 11-5. ④ "Check of LEV".</li> </ul>  |                                 |
| High pressure  | —                                      | Temperature indoor coil thermistor exceeds 70°C in HEAT mode. Temperature defrost thermistor exceeds 70°C in COOL mode.  | <ul style="list-style-type: none"> <li>•Check refrigerant circuit and refrigerant amount.</li> <li>•Check stop valve.</li> </ul>   |                                 |
| Fin temperature/ P.C. board temperature  | 7-time flash<br>2.5 seconds OFF        | Temperature of fin temperature thermistor on the inverter P.C. board exceeds 75 ~ 80°C, or temperature of P.C. board temperature thermistor on the inverter P.C. board exceeds 70 ~ 75°C.  | <ul style="list-style-type: none"> <li>•Check around outdoor unit.</li> <li>•Check outdoor unit air passage.</li> <li>•Refer to 11-5. ① "Check of outdoor fan motor".</li> </ul>             |                                 |
| Outdoor fan motor  | —                                      | Outdoor fan has stopped 3 times in a row within 30 seconds after outdoor fan start-up.   | <ul style="list-style-type: none"> <li>•Refer to 11-5. ① "Check of outdoor fan motor".</li> <li>•Refer to 11-5. ① "Check of inverter P.C. board".</li> </ul>                                 |                                 |
| Nonvolatile memory data  | 5-time flash<br>2.5 seconds OFF        | Nonvolatile memory data cannot be read properly.   | <ul style="list-style-type: none"> <li>•Replace the inverter P.C. board.</li> </ul>  |                                 |
| Power module   | 6-time flash<br>2.5 seconds OFF        | The interphase short circuit occurs in the output of the intelligent power module (IPM). The compressor winding shorts circuit.  | <ul style="list-style-type: none"> <li>•Refer to 11-5. ③ "How to check inverter/compressor".</li> </ul>  |                                 |
| Discharge temperature  | —                                      | Temperature of discharge temperature thermistor has been 50°C or less for 20 minutes.  | <ul style="list-style-type: none"> <li>•Refer to 11-5. ④ "Check of LEV".</li> <li>•Check refrigerant circuit and refrigerant amount.</li> </ul>  |                                 |
| DC voltage   | 8-time flash<br>2.5 seconds OFF        | DC voltage of inverter cannot be detected normally.  | <ul style="list-style-type: none"> <li>•Refer to 11-5. ③ "How to check inverter/compressor".</li> </ul>  |                                 |
| Each phase current of compressor   | 9-time flash<br>2.5 seconds OFF        | Each phase current of compressor cannot be detected normally.  |  |                                 |
| Overcurrent Compressor open-phase  | 10-time flash<br>2.5 seconds OFF       | Large current flows into intelligent power module (IPM). The open-phase operation of compressor is detected. The interphase short circuit occurs in the output of the intelligent power module (IPM). The compressor winding shorts circuit. | <ul style="list-style-type: none"> <li>•Reconnect compressor connector.</li> <li>•Refer to 11-5. ③ "How to check inverter/compressor".</li> </ul>  |                                 |
| Stop valve (Closed valve)  | 14-time flash<br>2.5 seconds OFF       | Closed valve is detected by compressor current.  | <ul style="list-style-type: none"> <li>•Check stop valve</li> </ul>  |                                 |

**NOTE: Blinking patterns of this mode differ from the ones of Troubleshooting check table (11-3).**

### 11-3. Trouble shooting check table

#### SUZ-KA25VA2.TH SUZ-KA35VA2.TH SUZ-KA50VA2.TH

| No. | Symptom   | LED indication                 | Abnormal point/ Condition  | Condition  | Correspondence   |
|-----|---|--------------------------------|--|--|--|
| 1   | Outdoor unit does not operate.                                | 1-time flash every 2.5 seconds | Outdoor power system   | Overcurrent protection stop is continuously performed 3 times within 1 minute after the compressor gets started, or failure of restart of compressor has repeated 24 times.                            | <ul style="list-style-type: none"> <li>•Reconnect connector of compressor.</li> <li>•Refer to 11-5. Ⓐ "How to check inverter/compressor".</li> <li>•Check stop valve.</li> </ul>                           |
| 2   |   |                                | Outdoor thermistors  | Discharge temperature thermistor, fin temperature thermistor, defrost thermistor, P.C. board temperature thermistor or ambient temperature thermistor shorts or opens during compressor running.       | •Refer to 11-5. Ⓔ "Check of outdoor thermistors".  |
| 3   |   |                                | Outdoor control system   | Nonvolatile memory data cannot be read properly.<br>(The left lamp of OPERATION INDICATOR lamp of the indoor unit lights up or flashes 7-time.)  | •Replace inverter P.C. board.  |
| 4   | Outdoor unit stops and restarts 3 minutes later' is repeated. | 6-time flash 2.5 seconds OFF   | Serial signal  | The communication fails between the indoor and outdoor unit for 3 minutes.   | •Refer to 11-5. Ⓛ "How to check miswiring and serial signal error."  |
| 5   |   | 11-time flash 2.5 seconds OFF  | Stop valve/ Closed valve   | Closed valve is detected by compressor current.  | •Check stop valve.   |
| 6   |   | 14-time flash 2.5 seconds OFF  | Outdoor unit (Other abnormality)   | Outdoor unit is defective.   | •Refer to 11-2.1. "Flow chart of the detailed outdoor unit failure mode recall function".  |
| 7   |   | 2-time flash 2.5 seconds OFF   | Overcurrent protection   | Large current flows into intelligent power module, or compressor repeats after 15 seconds when overcurrent protection occurs within 10 seconds after compressor starts. (Repeated 24 times at Maximum) | <ul style="list-style-type: none"> <li>•Reconnect connector of compressor.</li> <li>•Refer to 11-5. Ⓐ "How to check inverter/compressor".</li> <li>•Check stop valve.</li> </ul>                           |
| 8   | Outdoor unit operates.  | 3-time flash 2.5 seconds OFF   | Discharge temperature overheat protection                                | Temperature of discharge temperature thermistor exceeds 116°C, compressor stops. Compressor can restart if discharge temperature thermistor reads 100°C or less 3 minutes later.                       | <ul style="list-style-type: none"> <li>•Check refrigerant circuit and refrigerant amount.</li> <li>•Refer to 11-5. Ⓚ "Check of LEV".</li> </ul>  |
| 9   |   | 4-time flash 2.5 seconds OFF   | Fin temperature/P.C. board temperature thermistor overheat protection    | Temperature of fin temperature thermistor on the heat sink exceeds 75 ~ 80°C or temperature of P.C. board temperature thermistor on the inverter P.C. board exceeds 70 ~ 75°C.                         | <ul style="list-style-type: none"> <li>•Check around outdoor unit.</li> <li>•Check outdoor unit air passage.</li> <li>•Refer to 11-5. Ⓜ "Check of outdoor fan motor".</li> </ul>                           |
| 10  |   | 5-time flash 2.5 seconds OFF   | High pressure protection   | Indoor coil thermistor exceeds 70°C in HEAT mode. Defrost thermistor exceeds 70°C in COOL mode.  | <ul style="list-style-type: none"> <li>•Check refrigerant circuit and refrigerant amount.</li> <li>•Check stop valve.</li> </ul>   |
| 11  |   | 8-time flash 2.5 seconds OFF   | Compressor synchronous abnormality                                       | The waveform of compressor current is distorted.   | <ul style="list-style-type: none"> <li>•Reconnect connector of compressor.</li> <li>•Refer to 11-5. Ⓐ "How to check inverter/compressor".</li> </ul>   |
| 12  | Outdoor unit operates.  | 10-time flash 2.5 seconds OFF  | Outdoor fan motor  | Outdoor fan has stopped 3 times in a row within 30 seconds after outdoor fan start-up.   | <ul style="list-style-type: none"> <li>•Refer to 11-5. Ⓢ "Check of outdoor fan motor."</li> <li>•Refer to 11-5. Ⓚ "Check of inverter P.C. board."</li> </ul>   |
| 13  |   | 12-time flash 2.5 seconds OFF  | Each phase current of compressor   | Each phase current of compressor cannot be detected normally   | •Refer to 11-5. Ⓐ "How to check inverter/compressor".  |
| 14  |   | 13-time flash 2.5 seconds OFF  | DC voltage   | DC voltage of inverter cannot be detected normally.  | •Refer to 11-5. Ⓐ "How to check inverter/compressor".  |
| 15  | Outdoor unit operates.  | 1-time flash 2.5 seconds OFF   | Frequency drop by current protection                                     | Current from power outlet reaches the protection current, and compressor frequency lowers.   | The unit is normal, but check the following.   |
| 16  |   | 3-time flash 2.5 seconds OFF   | Frequency drop by high pressure protection                               | Temperature of indoor coil thermistor exceeds 55°C in HEAT mode, compressor frequency lowers.  | <ul style="list-style-type: none"> <li>•Check if indoor filters are clogged.</li> <li>•Check if refrigerant is short.</li> <li>•Check if indoor/outdoor unit air circulation is short cycled.</li> </ul>   |
| 17  |   |                                | Frequency drop by defrosting in COOL mode                                | Indoor coil thermistor reads 8°C or less in COOL mode, compressor frequency lowers.  |  |
| 18  | Outdoor unit operates.  | 4-time flash 2.5 seconds OFF   | Frequency drop by discharge temperature protection                       | Temperature of discharge temperature thermistor exceeds 111°C, compressor frequency lowers.  | <ul style="list-style-type: none"> <li>•Check refrigerant circuit and refrigerant amount.</li> <li>•Refer to 11-5. Ⓚ "Check of LEV".</li> <li>•Refer to 11-5. Ⓔ "Check of outdoor thermistors".</li> </ul> |
| 19  |   | 7-time flash 2.5 seconds OFF   | Low discharge temperature protection                                     | Temperature of discharge temperature thermistor has been 50°C or less for 20 minutes.  | <ul style="list-style-type: none"> <li>•Refer to 11-5. Ⓚ "Check of LEV".</li> <li>•Check refrigerant circuit and refrigerant amount.</li> </ul>  |
| 20  |   | 8-time flash 2.5 seconds OFF   | PAM protection PAM: Pulse Amplitude Modulation                           | The overcurrent flows into IGBT (Insulated Gate Bipolar transistor : TR821) or when the bus-bar voltage reaches 320 V or more, PAM stops and restarts.   | This is not malfunction. PAM protection will be activated in the following cases;<br>1 Instantaneous power voltage drop (Short time power failure)<br>2 When the power supply voltage is high.             |
| 20  | 9-time flash 2.5 seconds OFF                                  | Inverter check mode            | The connector of compressor is disconnected, inverter check mode starts. | •Check if the connector of the compressor is correctly connected.<br>Refer to 11-5. Ⓐ "How to check inverter/ compressor".   |  |

**NOTE:** 1. The location of LED is illustrated at the right figure. Refer to 11-6-1. or 11-6-2.  
2. LED is lighted during normal operation.

Inverter P.C. board(Parts side)

The flashing frequency shows the number of times the LED blinks after every 2.5-second OFF.  
(Example) When the flashing frequency is "2".

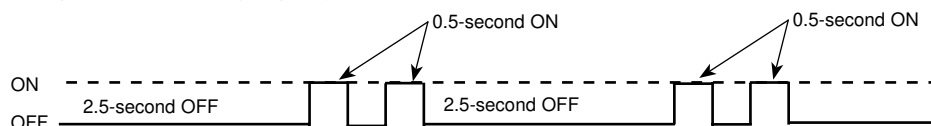
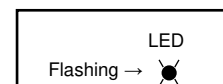

# SUZ-KA60VA2.TH

| No. | Symptom  | Indication |               | Abnormal point/Condition  | Condition   | Correspondence  |
|-----|--|------------|---------------|---|---|---|
|     |  | LED1 (Red) | LED2 (Yellow) |   |   |   |
| 1   | Outdoor unit does not operate.                                 | Lightning  | Twice         | Outdoor power system  | When IPM protection stop or lock protection stop is continuously performed three times within 1 minute after the compressor gets started, or when converter protection stop or bus-bar voltage protection stop is continuously performed three times within 3 minutes after start-up.   | <ul style="list-style-type: none"> <li>Check the connection of the compressor connecting wire.</li> <li>Refer to 11-5.⑥ "How to check inverter/compressor".</li> <li>Check the stop valve.</li> </ul>                       |
| 2   |  | Lightning  | 3 times       | Discharge temperature thermistor  | When a short circuit is detected in the thermistor during operation, or when an open circuit is detected in the thermistor after 10 minutes of compressor start-up.   | <ul style="list-style-type: none"> <li>Refer to 11-5.⑥ "Check of outdoor thermistor".</li> </ul>  |
| 3   |  | Lightning  | 4 times       | Fin temperature thermistor<br>P.C board temperature thermistor  | When a short or open circuit is detected in the thermistor during operation.  | <ul style="list-style-type: none"> <li>Refer to 11-5.⑥ "Check of outdoor thermistor".</li> <li>Replace the outdoor electronic control P.C. board.</li> </ul>  |
| 4   |  | Lightning  | 5 times       | Ambient temperature thermistor<br>Outdoor heat exchanger temperature thermistor<br>Defrost thermistor | When a short or open circuit is detected in the thermistor during operation.<br>When a short circuit is detected in the thermistor during operation, or when an open circuit is detected in the thermistor after 5 minutes (in cooling) and 10 minutes (in heating) of compressor start-up.<br>When a short circuit is detected in the thermistor during operation, or when an open circuit is detected in the thermistor after 5 minutes of compressor start-up. | <ul style="list-style-type: none"> <li>Refer to 11-5.⑥ "Check of outdoor thermistor".</li> </ul>  |
| 5   |  | Lightning  | 6 times       | Serial signal   | When the communication fails between the indoor and outdoor unit for 3 minutes.   | Refer to 11-5.⑥ "How to check mis-wiring and serial signal error."  |
| 6   |  | Lightning  | 7 times       | Nonvolatile memory data   | When the nonvolatile memory data cannot be read properly.   | <ul style="list-style-type: none"> <li>Replace the outdoor electronic control P.C. board.</li> </ul>  |
| 7   |  | Lightning  | 8 times       | Current sensor  | Current sensor protection stop is continuously performed twice.   | <ul style="list-style-type: none"> <li>Replace the power board.</li> </ul>  |
| 8   |  | Lightning  | 11 times      | Communication error between P.C. boards   | When the communication protection stop between boards is continuously performed twice.  | <ul style="list-style-type: none"> <li>Check the connecting wire between outdoor electronic control P.C. board and power board.</li> </ul>  |
| 9   |  | Lightning  | 12 times      | Zero cross detecting circuit  | The protection stop of the zero cross detecting circuit is continuously performed 10 times.   | <ul style="list-style-type: none"> <li>Check the connecting wire among outdoor electronic control P.C. board, noise filter P.C. board and power board.</li> </ul>   |
| 10  | 'Outdoor unit stops and restarts 3 minutes later' is repeated. | Twice      | Goes out      | IPM protection<br>Lock protection   | When over-current is detected after 30 seconds of compressor start-up.<br>When over-current is detected within 30 seconds of compressor start-up.   | <ul style="list-style-type: none"> <li>Reconnect compressor connector.</li> <li>Refer to 11-5.⑥ "How to check inverter/compressor".</li> <li>Check the stop valve.</li> <li>Check the power module (PAM module).</li> </ul> |
| 11  |  | 3 times    | Goes out      | Discharge temperature protection  | When temperature of discharge temperature thermistor exceeds 116.; compressor stops. Compressor can restart if discharge temperature thermistor reads 100°C or less 3 minutes later.  | <ul style="list-style-type: none"> <li>Check the amount of gas and refrigerant circuit.</li> <li>Refer to 11-5.⑥ "Check of LEV".</li> </ul>   |
| 12  |  | 4 times    | Goes out      | Fin temperature protection<br>P.C. board temperature protection                                       | When the fin temperature exceeds 87°C during operation.<br>When the P.C. board temperature exceeds 70°C during operation.   | <ul style="list-style-type: none"> <li>Check refrigerant circuit and refrigerant amount.</li> <li>Refer to 11-5.⑥ "Check of LEV".</li> </ul>  |
| 13  |  | 5 times    | Goes out      | High-pressure protection  | When high-pressure is detected with the high-pressure switch (HPS) during operation.<br>When the outdoor heat exchanger temperature exceeds 70°C during cooling or when indoor gas pipe temperature exceeds 70°C during heating.  | <ul style="list-style-type: none"> <li>Check around of gas and the refrigerant circuit.</li> <li>Check of stop valve.</li> </ul>  |
| 14  |  | 8 times    | Goes out      | Converter protection  | When a failure is detected in the operation of the converter during operation.  | <ul style="list-style-type: none"> <li>Replace the power board.</li> </ul>  |
| 15  |  | 9 times    | Goes out      | Bus-bar voltage protection (1)<br>Bus-bar voltage protection (2)                                      | When the bus-bar voltage exceeds 400V or falls to 200V or below during compressor operating.<br>When the bus-bar voltage exceeds 400V or falls to 50V or below during compressor operating.   | <ul style="list-style-type: none"> <li>Replace the power board.</li> </ul>  |
| 16  |  | 13 times   | Goes out      | Outdoor fan motor   | When failure occurs continuously three times within 30 seconds after the fan gets started.  | <ul style="list-style-type: none"> <li>Refer to 11-5.⑥ "Check of outdoor fan motor".</li> </ul>   |
| 17  |  | Lighting   | 8 times       | Current sensor protection   | When a short or open circuit is detected in the current sensor during compressor operating.   | <ul style="list-style-type: none"> <li>Replace the power board.</li> </ul>  |
| 18  |  | Lighting   | 11 times      | Communication between P.C. boards protection  | Communication error occurs between the outdoor electronic control P.C. board and power board for more than 10 seconds.  | <ul style="list-style-type: none"> <li>Check the connecting wire between outdoor electronic control P.C. board and power board.</li> </ul>  |
| 19  |  | Lighting   | 12 times      | Zero cross detecting circuit protection   | When zero cross signal cannot be detected while the compressor is operating.  | <ul style="list-style-type: none"> <li>Check the connecting wire among outdoor electronic control P.C. board, noise filter P.C. board and power board.</li> </ul>   |

NOTE 1. The location of LED is illustrated at the right figure.  
2. LED is lighted during normal operation.

Outdoor electronic control P.C. board (Parts side)

The flashing frequency shows the number of times the LED blinks after every 2.5-second OFF.  
(Example) When the flashing frequency is "2".

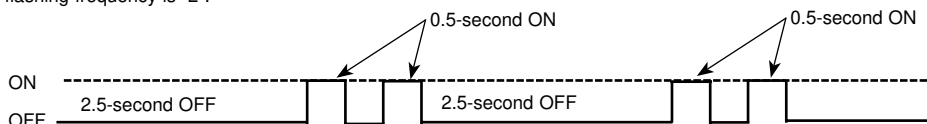
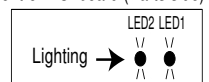

## SUZ-KA60VA2.TH

| No. | Symptom                | Indication |                                      | Abnormal point/Condition   | Condition  | Correspondence   |
|-----|------------------------|------------|--------------------------------------|--|--|--|
|     |                        | LED1 (Red) | LED2 (Yellow)                        |  |  |  |
| 20  | Outdoor unit operates. | Once       | Lighting                             | Primary current protection   | When the input current exceeds 15A.  | These symptoms do not mean any abnormality of the product, but check the following points. <ul style="list-style-type: none"> <li>• Check if indoor filters are clogged.</li> <li>• Check if refrigerant is short.</li> <li>• Check if indoor/outdoor unit air circulation is short cycled.</li> </ul> |
| 21  |                        |            |                                      | Twice  | Lighting   |  |
| 22  |                        | 3 times    | Lighting                             |  |  |  |
|     |                        |            |                                      | Defrosting in cooling  | When the indoor gas pipe temperature falls 3°C or below during cooling.  |  |
| 23  |                        | 4 times    | Lighting                             | Discharge temperature protection   | When the discharge temperature exceeds 100°C during operation.   |  |
| 24  | 5 times                | Lighting   | Low discharge temperature protection | When the frequency of the compressor is kept 80Hz or more and the discharge temperature is kept under 39°C for more than 20 minutes. | <ul style="list-style-type: none"> <li>• Refer to 11-5.⑥ "Check of LEV".</li> <li>• Check refrigerant circuit and refrigerant amount.</li> </ul> |  |
| 25  | Outdoor unit operates  | 9 times    | Lighting                             | Cooling high-pressure protection   | When the outdoor heat exchanger temperature exceeds 58°C during operation.   | This symptom does not mean any abnormality of the product, but check the following points. <ul style="list-style-type: none"> <li>• Check if indoor filters are clogged.</li> <li>• Check if refrigerant is short.</li> <li>• Check if indoor/outdoor unit air circulation is short cycled.</li> </ul> |
| 26  |                        | Lighting   | Lighting                             | Inverter check mode  | When the unit is operated with emergency operation switch.   | —  |
|     |                        |            |                                      | Normal   | —  | —  |

# SUZ-KA71VA2.TH

| No. | Symptom  | LED indication                   | Abnormal point/ Condition  | Condition   | Correspondence   |  |
|-----|--|----------------------------------|--|---|--|--|
| 1   | Outdoor unit does not operate.                                 | 1-time flash every 2.5 seconds   | Outdoor power system   | Overcurrent protection stop is continuously performed 3 times within 1 minute after the compressor gets started.  | <ul style="list-style-type: none"> <li>•Reconnect connector of compressor.</li> <li>•Refer to 11-5.⑩ "How to check inverter/compressor".</li> <li>•Check stop valve.</li> </ul>                            |  |
| 2   |  |                                  | Outdoor thermistors  | Discharge temperature thermistor, fin temperature thermistor, defrost thermistor, P.C. board temperature thermistor, outdoor heat exchanger temperature thermistor or ambient temperature thermistor shorts or opens during compressor running. | •Refer to 11-5.⑩ "Check of outdoor thermistors".   |  |
| 3   |  |                                  | Outdoor control system   | Nonvolatile memory data cannot be read properly.<br>(The upper lamp of OPERATION INDICATOR lamp of the indoor unit lights up or flashes 7-time.)  | •Replace inverter P.C. board.  |  |
| 4   |  | 6-time flash<br>2.5 seconds OFF  | Serial signal  | The communication fails between the indoor and outdoor unit for 3 minutes.  | •Refer to 11-5. ⑩ "How to check miswiring and serial signal error."  |  |
| 5   |  | 11-time flash<br>2.5 seconds OFF | Stop valve/<br>Closed valve  | Closed valve is detected by compressor current.   | •Check stop valve.   |  |
| 6   |  | 14-time flash<br>2.5 seconds OFF | Outdoor unit<br>(Other abnormality)                                    | Outdoor unit is defective.  | •Refer to 11-2.1. "Flow chart of the detailed outdoor unit failure mode recall function".  |  |
| 7   | 'Outdoor unit stops and restarts 3 minutes later' is repeated. | 2-time flash<br>2.5 seconds OFF  | Overcurrent protection   | Large current flows into intelligent power module.  | <ul style="list-style-type: none"> <li>•Reconnect connector of compressor.</li> <li>•Refer to 11-5. ⑩ "How to check inverter/compressor".</li> <li>•Check stop valve.</li> </ul>                           |  |
| 8   | Outdoor unit stops and restarts 3 minutes later' is repeated.  | 3-time flash<br>2.5 seconds OFF  | Discharge temperature overheat protection                              | Temperature of discharge temperature thermistor exceeds 116°C, compressor stops. Compressor can restart if discharge temperature thermistor reads 100°C or less 3 minutes later.  | <ul style="list-style-type: none"> <li>•Check refrigerant circuit and refrigerant amount.</li> <li>•Refer to 11-5. ⑩ "Check of LEV".</li> </ul>  |  |
| 9   |  | 4-time flash<br>2.5 seconds OFF  | Fin temperature /P.C. board temperature thermistor overheat protection | Temperature of fin temperature thermistor on the heat sink exceeds 75 ~ 80°C or temperature of P.C. board temperature thermistor on the inverter P.C.board exceeds 70 ~ 75°C.   | <ul style="list-style-type: none"> <li>•Check around outdoor unit.</li> <li>•Check outdoor unit air passage.</li> <li>•Refer to 11-5. ⑩ "Check of outdoor fan motor".</li> </ul>                           |  |
| 10  |  | 5-time flash<br>2.5 seconds OFF  | High pressure protection   | Indoor coil thermistor exceeds 70°C in HEAT mode. Defrost thermistor exceeds 70°C in COOL mode.   | <ul style="list-style-type: none"> <li>•Check refrigerant circuit and refrigerant amount.</li> <li>•Check stop valve.</li> </ul>   |  |
| 11  |  | 8-time flash<br>2.5 seconds OFF  | Compressor synchronous abnormality                                     | The waveform of compressor current is distorted.  | <ul style="list-style-type: none"> <li>•Reconnect connector of compressor.</li> <li>•Refer to 11-5. ⑩ "How to check inverter/compressor".</li> </ul>   |  |
| 12  |  | 10-time flash<br>2.5 seconds OFF | Outdoor fan motor  | Outdoor fan has stopped 3 times in a row within 30 seconds after outdoor fan start-up.  | <ul style="list-style-type: none"> <li>•Refer to 11-5. ⑩ "Check of outdoor fan motor."</li> <li>•Refer to 11-5. ⑩ "Check of inverter P.C. board."</li> </ul>   |  |
| 13  |  | 12-time flash<br>2.5 seconds OFF | Each phase current of compressor                                       | Each phase current of compressor cannot be detected normally.   | •Refer to 11-5. ⑩ "How to check inverter/compressor".  |  |
| 14  |  | 13-time flash<br>2.5 seconds OFF | DC voltage   | DC voltage of inverter cannot be detected normally.   | •Refer to 11-5. ⑩ "How to check inverter/compressor".  |  |
| 15  |  | Outdoor unit operates.           | 1-time flash<br>2.5 seconds OFF  | Frequency drop by current protection  | Current from power outlet is nearing breaker capacity. PFC module stops due to overcurrent.  | The unit is normal, but check the following.   |
| 16  |  | Outdoor unit operates.           | 3-time flash<br>2.5 seconds OFF  | Frequency drop by high pressure protection  | Temperature of indoor coil thermistor exceeds 55°C in HEAT mode, compressor frequency lowers.  | <ul style="list-style-type: none"> <li>•Check if indoor filters are clogged.</li> <li>•Check if refrigerant is short.</li> <li>•Check if indoor/outdoor unit air circulation is short cycled.</li> </ul> |
|     |  |                                  | 4-time flash<br>2.5 seconds OFF  | Frequency drop by defrosting in COOL mode   | Indoor coil thermistor reads 8°C or less in COOL mode, compressor frequency lowers.  |  |
| 17  | Outdoor unit operates.   | 4-time flash<br>2.5 seconds OFF  | Frequency drop by discharge temperature protection                     | Temperature of discharge temperature thermistor exceeds 111°C, compressor frequency lowers.   | <ul style="list-style-type: none"> <li>•Check refrigerant circuit and refrigerant amount.</li> <li>•Refer to 11-5. ⑩ "Check of LEV".</li> <li>•Refer to 11-5. ⑩ "Check of outdoor thermistors".</li> </ul> |  |
| 18  | Outdoor unit operates.   | 7-time flash<br>2.5 seconds OFF  | Low discharge temperature protection                                   | Temperature of discharge temperature thermistor has been 50°C or less for 20 minutes.   | <ul style="list-style-type: none"> <li>•Refer to 11-5. ⑩ "Check of LEV".</li> <li>•Check refrigerant circuit and refrigerant amount.</li> </ul>  |  |
| 19  |  | 8-time flash<br>2.5 seconds OFF  | Zero cross detecting circuit   | Zero cross signal for PAM control cannot be detected.   | This is not malfunction. PAM protection will be activated in the following cases:<br>1 Instantaneous power voltage drop. (Short time power failure)<br>2 When the power supply voltage is high.            |  |
| 20  |  | 9-time flash<br>2.5 seconds OFF  | Inverter check mode  | The connector of compressor is disconnected, inverter check mode starts.  | •Check if the connector of the compressor is correctly connected. Refer to 11-5. ⑩ "How to check inverter/compressor".   |  |

**NOTE:** 1. The location of LED is illustrated at the right figure. Refer to 11-6-3.  
2. LED is lighted during normal operation.

Inverter P.C. board

The flashing frequency shows the number of times the LED blinks after every 2.5-second OFF.  
(Example) When the flashing frequency is "2".

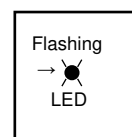
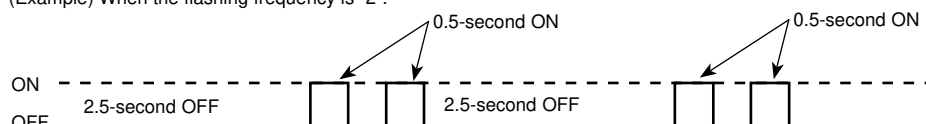

**11-4. Trouble criterion of main parts (1)**  
**SUZ-KA25VA2.TH SUZ-KA35VA2.TH**

| Part name   | Check method and criterion  | Figure                 |        |           |                   |                |                |           |                 |                 |     |     |  |
|---|---|------------------------|--------|-----------|-------------------|----------------|----------------|-----------|-----------------|-----------------|-----|-----|--|
| Defrost thermistor (RT61)<br>Fin temperature thermistor (RT64)<br>Ambient temperature thermistor (RT65)<br>Outdoor heat exchanger temperature thermistor (RT68) | Measure the resistance using a tester.<br><br>Refer to 11-6. "Test point diagram and voltage", 11-6-1. "Inverter P.C. board", for the chart of thermistor.  |                        |        |           |                   |                |                |           |                 |                 |     |     |  |
| Discharge temperature thermistor (RT62)   | Measure the resistance using a tester.<br>Before measurement, hold the thermistor with your hands to warm it up.<br>Refer to 11-6. "Test point diagram and voltage", 11-6-1. "Inverter P.C. board", for the chart of thermistor.  |                        |        |           |                   |                |                |           |                 |                 |     |     |  |
| Compressor  | Measure the resistance between terminals using a tester.<br>(Temperature : -20°C ~ 40°C)  |                        |        |           |                   |                |                |           |                 |                 |     |     |  |
|   | <table border="1"> <thead> <tr> <th></th> <th colspan="2">Normal</th> </tr> <tr> <th></th> <th>SUZ-KA25VA2.TH</th> <th>SUZ-KA35VA2.TH</th> </tr> </thead> <tbody> <tr> <td>U-V</td> <td rowspan="3">1.36 Ω ~ 1.93 Ω</td> <td rowspan="3">1.52 Ω ~ 2.17 Ω</td> </tr> <tr> <td>U-W</td> </tr> <tr> <td>V-W</td> </tr> </tbody> </table> |                        | Normal |           |                   | SUZ-KA25VA2.TH | SUZ-KA35VA2.TH | U-V       | 1.36 Ω ~ 1.93 Ω | 1.52 Ω ~ 2.17 Ω | U-W | V-W |  |
|   | Normal  |                        |        |           |                   |                |                |           |                 |                 |     |     |  |
|   | SUZ-KA25VA2.TH  | SUZ-KA35VA2.TH         |        |           |                   |                |                |           |                 |                 |     |     |  |
| U-V   | 1.36 Ω ~ 1.93 Ω   | 1.52 Ω ~ 2.17 Ω        |        |           |                   |                |                |           |                 |                 |     |     |  |
| U-W   |   |                        |        |           |                   |                |                |           |                 |                 |     |     |  |
| V-W   |   |                        |        |           |                   |                |                |           |                 |                 |     |     |  |
| Outdoor fan motor   | Measure the resistance between terminals using a tester.<br>(Temperature : -20°C ~ 40°C)  |                        |        |           |                   |                |                |           |                 |                 |     |     |  |
|   | <table border="1"> <thead> <tr> <th>Color of the lead wire</th> <th>Normal</th> </tr> </thead> <tbody> <tr> <td>WHT - BLK</td> <td rowspan="3">29 Ω ~ 42 Ω</td> </tr> <tr> <td>BLK - RED</td> </tr> <tr> <td>RED - WHT</td> </tr> </tbody> </table>   | Color of the lead wire | Normal | WHT - BLK | 29 Ω ~ 42 Ω       | BLK - RED      | RED - WHT      |           |                 |                 |     |     |  |
| Color of the lead wire  | Normal  |                        |        |           |                   |                |                |           |                 |                 |     |     |  |
| WHT - BLK   | 29 Ω ~ 42 Ω   |                        |        |           |                   |                |                |           |                 |                 |     |     |  |
| BLK - RED   |   |                        |        |           |                   |                |                |           |                 |                 |     |     |  |
| RED - WHT   |   |                        |        |           |                   |                |                |           |                 |                 |     |     |  |
| R.V. coil (21S4)  | Measure the resistance between terminals using a tester.<br>(Temperature : -20°C ~ 40°C)  |                        |        |           |                   |                |                |           |                 |                 |     |     |  |
|   | <table border="1"> <thead> <tr> <th></th> <th>Normal</th> </tr> </thead> <tbody> <tr> <td></td> <td>1.19 kΩ ~ 1.78 kΩ</td> </tr> </tbody> </table>  |                        | Normal |           | 1.19 kΩ ~ 1.78 kΩ |                |                |           |                 |                 |     |     |  |
|   | Normal  |                        |        |           |                   |                |                |           |                 |                 |     |     |  |
|   | 1.19 kΩ ~ 1.78 kΩ   |                        |        |           |                   |                |                |           |                 |                 |     |     |  |
| Expansion valve coil (LEV)  | Measure the resistance using a tester.<br>(Temperature : -20°C ~ 40°C)  |                        |        |           |                   |                |                |           |                 |                 |     |     |  |
|   | <table border="1"> <thead> <tr> <th>Color of the lead wire</th> <th>Normal</th> </tr> </thead> <tbody> <tr> <td>WHT - RED</td> <td rowspan="4">37 Ω ~ 54 Ω</td> </tr> <tr> <td>RED - ORN</td> </tr> <tr> <td>YLW - BRN</td> </tr> <tr> <td>BRN - BLU</td> </tr> </tbody> </table>   | Color of the lead wire | Normal | WHT - RED | 37 Ω ~ 54 Ω       | RED - ORN      | YLW - BRN      | BRN - BLU |                 |                 |     |     |  |
| Color of the lead wire  | Normal  |                        |        |           |                   |                |                |           |                 |                 |     |     |  |
| WHT - RED   | 37 Ω ~ 54 Ω   |                        |        |           |                   |                |                |           |                 |                 |     |     |  |
| RED - ORN   |   |                        |        |           |                   |                |                |           |                 |                 |     |     |  |
| YLW - BRN   |   |                        |        |           |                   |                |                |           |                 |                 |     |     |  |
| BRN - BLU   |   |                        |        |           |                   |                |                |           |                 |                 |     |     |  |

## 11-4. Trouble criterion of main parts (2)

### SUZ-KA50VA2.TH SUZ-KA60VA2.TH SUZ-KA71VA2.TH

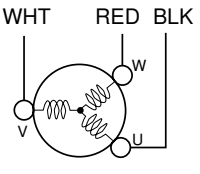
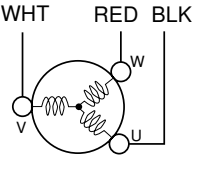
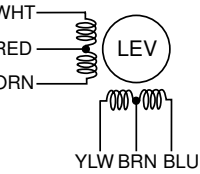
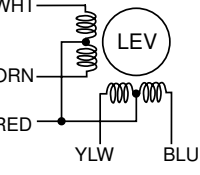
| Part name   | Check method and criterion   | Figure                 |           |                   |                   |  |                   |   |   |           |           |   |
|---|--|------------------------|-----------|-------------------|-------------------|--|-------------------|---|---|-----------|-----------|---|
| Defrost thermistor (RT61)<br>Fin temperature thermistor (RT64)<br>Ambient temperature thermistor (RT65)<br>Outdoor heat exchanger temperature thermistor (RT68)   | Measure the resistance using a tester.<br><br>Refer to 11-6. "Test point diagram and voltage", 11-6-4. "Outdoor electronic control P.C. board" or 11-6-2, 11-6-3. "Inverter P.C. board", for the chart of thermistor.  |                        |           |                   |                   |  |                   |   |   |           |           |   |
| Discharge temperature thermistor (RT62)   | Measure the resistance using a tester.<br>Before measurement, hold the thermistor with your hands to warm it up.<br><br>Refer to 11-6. "Test point diagram and voltage", 11-6-4. "Outdoor electronic control P.C. board" or 11-6-2, 11-6-3. "Inverter P.C. board", for the chart of thermistor.  |                        |           |                   |                   |  |                   |   |   |           |           |   |
| Compressor  | Measure the resistance between terminals using a tester.<br>(Temperature : -10°C ~ 40°C)<br><table border="1" style="width: 100%; text-align: center;"> <thead> <tr> <th colspan="2">Normal</th> </tr> <tr> <th>SUZ-KA50/60VA2.TH</th> <th>SUZ-KA71VA2.TH</th> </tr> </thead> <tbody> <tr> <td>0.86 Ω ~ 1.06 Ω</td> <td>0.92 Ω ~ 1.12 Ω</td> </tr> </tbody> </table>   | Normal                 |           | SUZ-KA50/60VA2.TH | SUZ-KA71VA2.TH    | 0.86 Ω ~ 1.06 Ω                            | 0.92 Ω ~ 1.12 Ω   |   |   |           |           |   |
| Normal  |  |                        |           |                   |                   |  |                   |   |   |           |           |   |
| SUZ-KA50/60VA2.TH   | SUZ-KA71VA2.TH   |                        |           |                   |                   |  |                   |   |   |           |           |   |
| 0.86 Ω ~ 1.06 Ω   | 0.92 Ω ~ 1.12 Ω  |                        |           |                   |                   |  |                   |   |   |           |           |   |
| Outdoor fan motor   | Measure the resistance between lead wires using a tester.<br>(Temperature : -10°C ~ 40°C)<br><table border="1" style="width: 100%; text-align: center;"> <thead> <tr> <th rowspan="2">Color of the lead wire</th> <th colspan="2">Normal</th> </tr> <tr> <th>SUZ-KA50/60VA2.TH</th> <th>SUZ-KA71VA2.TH</th> </tr> </thead> <tbody> <tr> <td>RED - BLK</td> <td rowspan="3">13.4 Ω ~ 16.4 Ω</td> <td rowspan="3">12 Ω ~ 17 Ω</td> </tr> <tr> <td>BLK - WHT</td> </tr> <tr> <td>WHT - RED</td> </tr> </tbody> </table> | Color of the lead wire | Normal    |                   | SUZ-KA50/60VA2.TH | SUZ-KA71VA2.TH                             | RED - BLK         | 13.4 Ω ~ 16.4 Ω   | 12 Ω ~ 17 Ω   | BLK - WHT | WHT - RED |  |
| Color of the lead wire  | Normal   |                        |           |                   |                   |  |                   |   |   |           |           |   |
|   | SUZ-KA50/60VA2.TH  | SUZ-KA71VA2.TH         |           |                   |                   |  |                   |   |   |           |           |   |
| RED - BLK   | 13.4 Ω ~ 16.4 Ω  | 12 Ω ~ 17 Ω            |           |                   |                   |  |                   |   |   |           |           |   |
| BLK - WHT   |  |                        |           |                   |                   |  |                   |   |   |           |           |   |
| WHT - RED   |  |                        |           |                   |                   |  |                   |   |   |           |           |   |
| R.V. coil (21S4)  | Measure the resistance using a tester.<br>(Temperature : -10°C ~ 40°C)<br><table border="1" style="width: 100%; text-align: center;"> <thead> <tr> <th colspan="2">Normal</th> </tr> <tr> <th>SUZ-KA50/60VA2.TH</th> <th>SUZ-KA71VA2.TH</th> </tr> </thead> <tbody> <tr> <td>1.32 kΩ ~ 1.62 kΩ</td> <td>1.19 kΩ ~ 1.78 kΩ</td> </tr> </tbody> </table>   | Normal                 |           | SUZ-KA50/60VA2.TH | SUZ-KA71VA2.TH    | 1.32 kΩ ~ 1.62 kΩ                          | 1.19 kΩ ~ 1.78 kΩ |   |   |           |           |   |
| Normal  |  |                        |           |                   |                   |  |                   |   |   |           |           |   |
| SUZ-KA50/60VA2.TH   | SUZ-KA71VA2.TH   |                        |           |                   |                   |  |                   |   |   |           |           |   |
| 1.32 kΩ ~ 1.62 kΩ   | 1.19 kΩ ~ 1.78 kΩ  |                        |           |                   |                   |  |                   |   |   |           |           |   |
| Expansion valve coil (LEV)  | Measure the resistance using a tester.<br>(Temperature : -10°C ~ 40°C)<br><b>SUZ-KA50/60VA2.TH</b><br><table border="1" style="width: 100%; text-align: center;"> <thead> <tr> <th>Color of the lead wire</th> <th>Normal</th> </tr> </thead> <tbody> <tr> <td>WHT - RED</td> <td rowspan="4">37.4 Ω ~ 53.9 Ω</td> </tr> <tr> <td>RED - ORN</td> </tr> <tr> <td>YLW - BRN</td> </tr> <tr> <td>BRN - BLU</td> </tr> </tbody> </table>   | Color of the lead wire | Normal    | WHT - RED         | 37.4 Ω ~ 53.9 Ω   | RED - ORN                                  | YLW - BRN         | BRN - BLU   |  |           |           |   |
|   | Color of the lead wire   | Normal                 |           |                   |                   |  |                   |   |   |           |           |   |
| WHT - RED   | 37.4 Ω ~ 53.9 Ω  |                        |           |                   |                   |  |                   |   |   |           |           |   |
| RED - ORN   |  |                        |           |                   |                   |  |                   |   |   |           |           |   |
| YLW - BRN   |  |                        |           |                   |                   |  |                   |   |   |           |           |   |
| BRN - BLU   |  |                        |           |                   |                   |  |                   |   |   |           |           |   |
| <b>SUZ-KA70VA2.TH</b><br><table border="1" style="width: 100%; text-align: center;"> <thead> <tr> <th>Color of the lead wire</th> <th>Normal</th> </tr> </thead> <tbody> <tr> <td>RED - ORN</td> <td rowspan="4">37 Ω ~ 54 Ω</td> </tr> <tr> <td>RED - WHT</td> </tr> <tr> <td>RED - BLU</td> </tr> <tr> <td>RED - YLW</td> </tr> </tbody> </table> | Color of the lead wire   | Normal                 | RED - ORN | 37 Ω ~ 54 Ω       | RED - WHT         | RED - BLU                                  | RED - YLW         |  |   |           |           |   |
| Color of the lead wire  | Normal   |                        |           |                   |                   |  |                   |   |   |           |           |   |
| RED - ORN   | 37 Ω ~ 54 Ω  |                        |           |                   |                   |  |                   |   |   |           |           |   |
| RED - WHT   |  |                        |           |                   |                   |  |                   |   |   |           |           |   |
| RED - BLU   |  |                        |           |                   |                   |  |                   |   |   |           |           |   |
| RED - YLW   |  |                        |           |                   |                   |  |                   |   |   |           |           |   |
| High pressure switch (HPS)<br><b>SUZ-KA60VA2.TH</b>   | <table border="1" style="width: 100%; text-align: center;"> <thead> <tr> <th colspan="2">Pressure</th> </tr> </thead> <tbody> <tr> <td>3.7 ± 0.15 MPa</td> <td>Close</td> </tr> <tr> <td>4.8 ± <sup>0.05</sup>/<sub>0.1</sub> MPa</td> <td>Open</td> </tr> </tbody> </table>   | Pressure               |           | 3.7 ± 0.15 MPa    | Close             | 4.8 ± <sup>0.05</sup> / <sub>0.1</sub> MPa | Open              |   |   |           |           |   |
| Pressure  |  |                        |           |                   |                   |  |                   |   |   |           |           |   |
| 3.7 ± 0.15 MPa  | Close  |                        |           |                   |                   |  |                   |   |   |           |           |   |
| 4.8 ± <sup>0.05</sup> / <sub>0.1</sub> MPa  | Open   |                        |           |                   |                   |  |                   |   |   |           |           |   |

## 11-5. Troubleshooting flow

### A How to check inverter/compressor

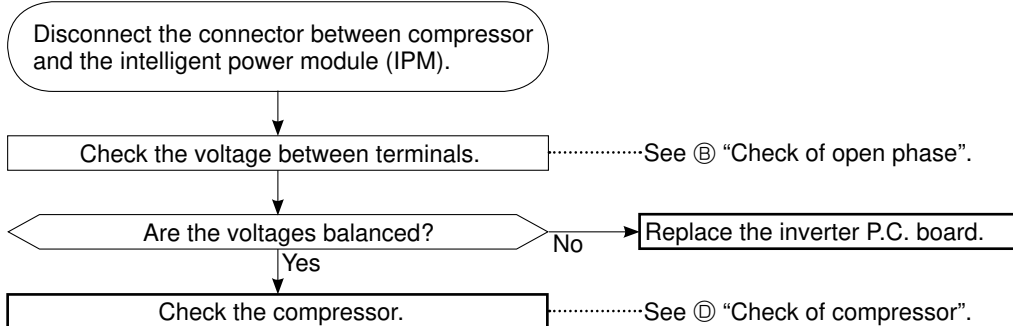

### B Check of open phase

- With the connector between the compressor and the intelligent power module disconnected, activate the inverter and check if the inverter is normal by measuring the balance of voltage between the terminals.

The output voltage values have the tolerance of  $\pm 20\%$ .

<< Operation method(Test run operation)>>

1. Press the EMERGENCY OPERATION switch or the Test button to COOL or HEAT mode.
2. Test run operation starts and continues to operate for 30 minutes.
3. Compressor starts at rated frequency in COOL mode or 58Hz in HEAT mode.
4. Indoor fan operates at High speed.
5. After 30 minutes, test run operation finishes and EMERGENCY OPERATION starts.
6. To cancel test run operation (EMERGENCY OPERATION), press the EMERGENCY OPERATION switch or the ON/OFF button on remote controller.

<<Measurement point>>

At 3 points  
 BLK (U) - WHT (V)  
 BLK (U) - RED (W)  
 WHT (V) - RED (W)

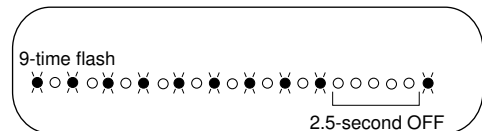

- NOTE:**
1. Output voltage varies according to power supply voltage.
  2. Measure the voltage by analog type tester.
  3. During this check, LED of the inverter P.C. board flashes 9 times. (Refer to 11-6-1, 11-6-2)

### C Check of compressor

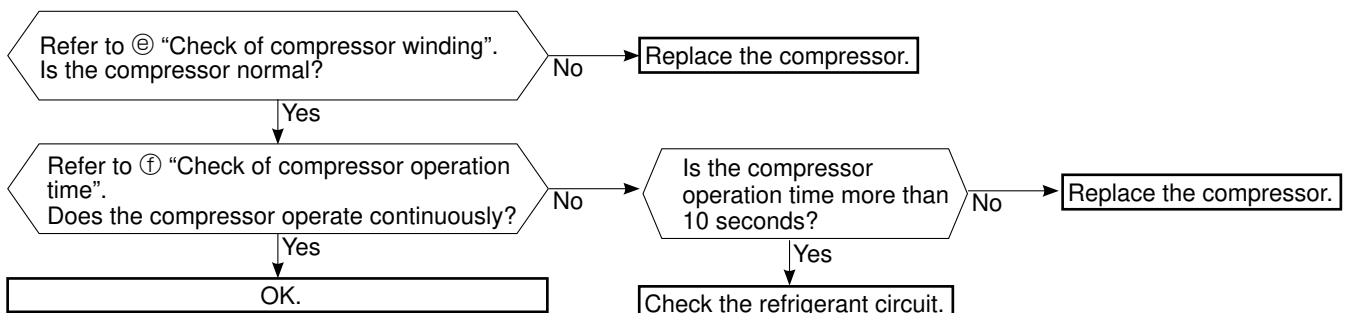

**D Check of compressor winding**

- Disconnect the connector between the compressor and intelligent power module, and measure the resistance between the compressor terminals.
- <<Measurement point>>  
 at 3 points  
 BLK-WHT  
 BLK-RED      \* Measure the resistance between the lead wires at 3 points.  
 WHT-RED
- <<Judgement>>  
 Refer to 11-4.  
 0 [Ω] .....Abnormal [short]  
 Infinite [Ω] .....Abnormal [open]
- NOTE:** Be sure to zero the ohmmeter before measurement.

**E Check of compressor operation time**

- Connect the compressor and activate the inverter. Then measure the time until the inverter stops due to over current.
- <<Operation method>>  
 Start heating or cooling operation by pressing EMERGENCY OPERATION switch on the indoor unit.  
 (TEST RUN OPERATION : Refer to 11-5 ⑥.)
- <<Measurement>>  
 Measure the time from the start of compressor to the stop of compressor due to overcurrent.

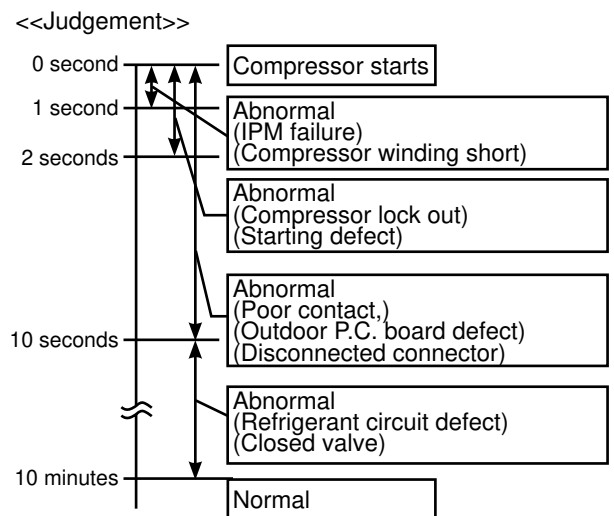

**F Check of outdoor thermistors**

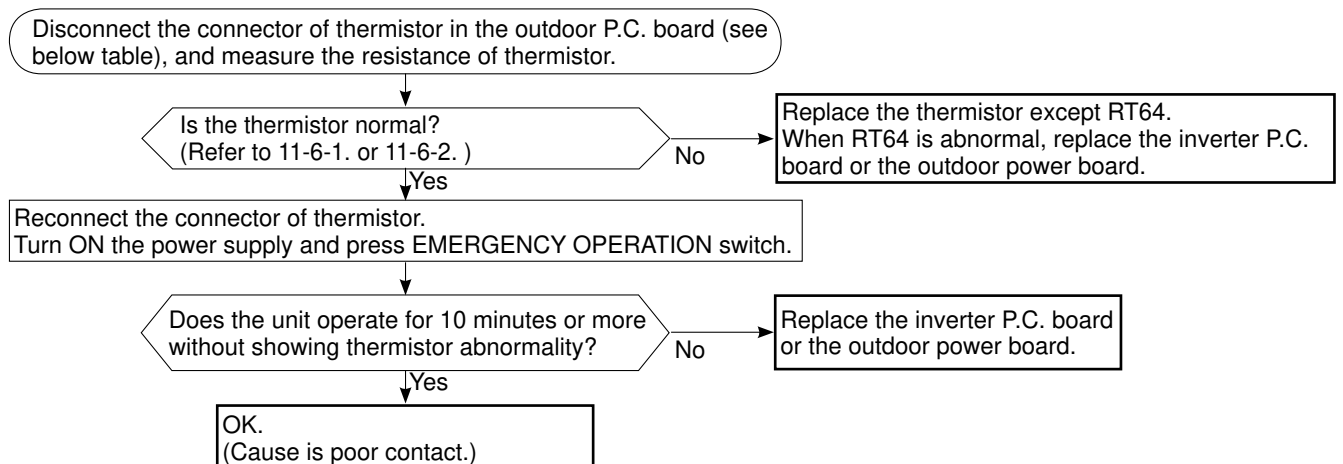

| Thermistor                         | Symbol | Connector, Pin No.          | Board               |
|------------------------------------|--------|-----------------------------|---------------------|
| Defrost                            | RT61   | Between CN641 pin1 and pin2 | Inverter P.C. board |
| Discharge temperature              | RT62   | Between CN641 pin3 and pin4 |                     |
| Fin temperature                    | RT64   | Between CN642 pin1 and pin2 |                     |
| Ambient temperature                | RT65   | Between CN643 pin1 and pin2 |                     |
| Outdoor heat exchanger temperature | RT68   | Between CN644 pin1 and pin3 |                     |

**G Check of R.V. coil**

- \* First of all, measure the resistance of R.V. coil to check if the coil is defective. Refer to 11-4.
- \* In case CN721 is not connected or R.V. coil is open, voltage is generated between the terminal pins of the connector although any signal is not being transmitted to R.V. coil.  
Check if CN721 is connected.

**Unit operates COOL mode even if it is set to HEAT mode.**

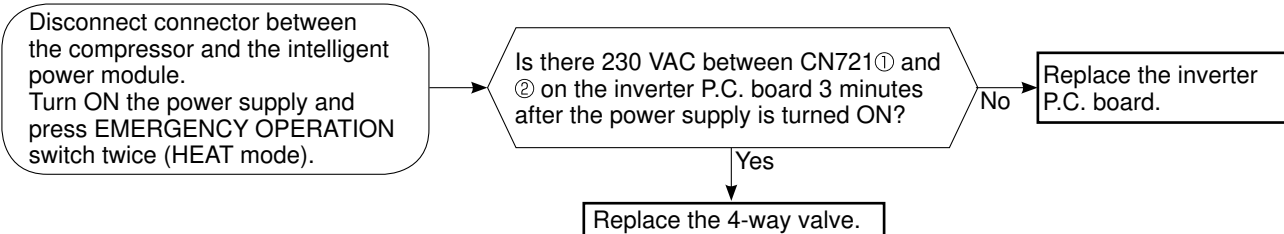

**Unit operates HEAT mode even if it is set to COOL mode.**

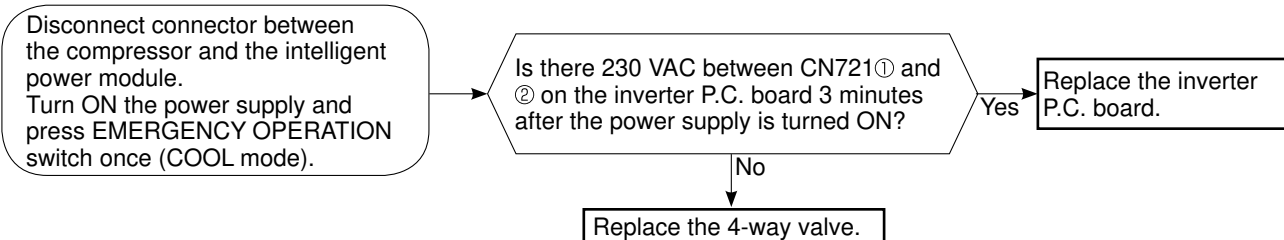

**H Check of outdoor fan motor**

SUZ-KA25/35VA2.TH

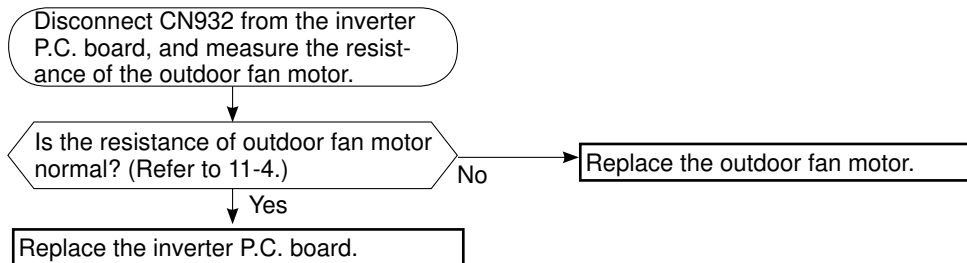

SUZ-KA50VA2.TH

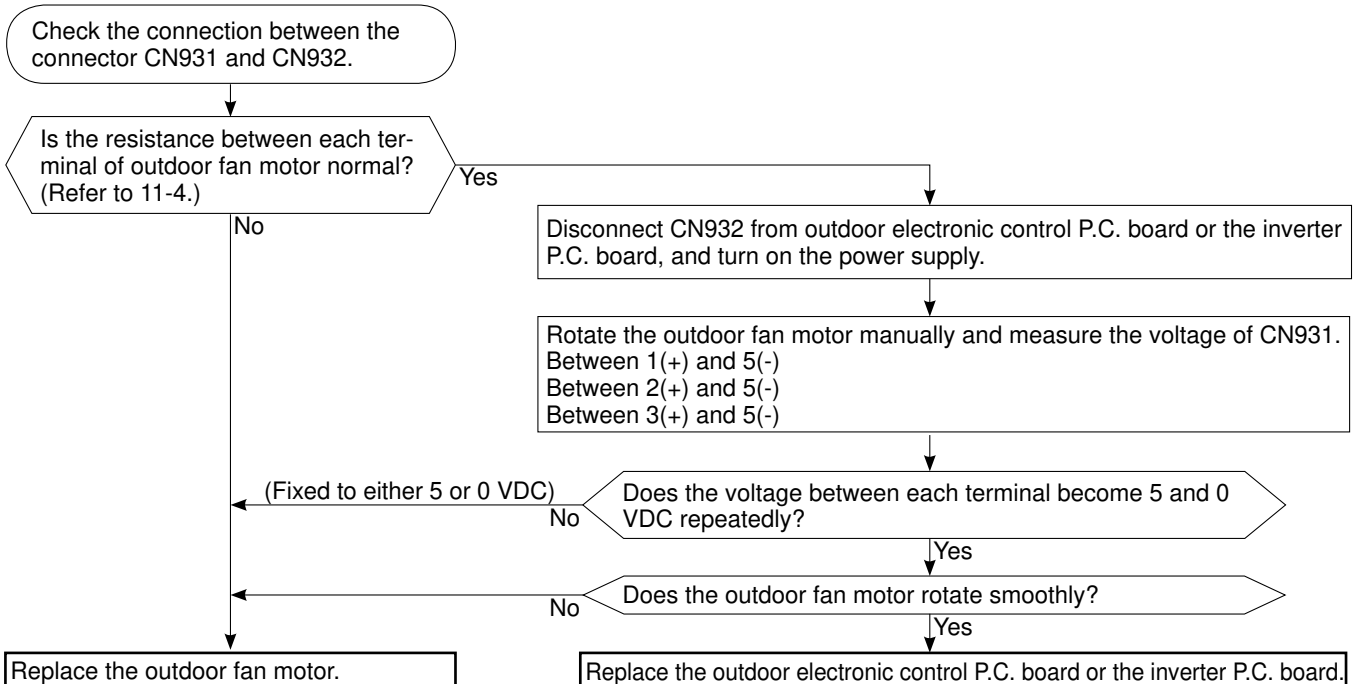

**I Check of power supply**

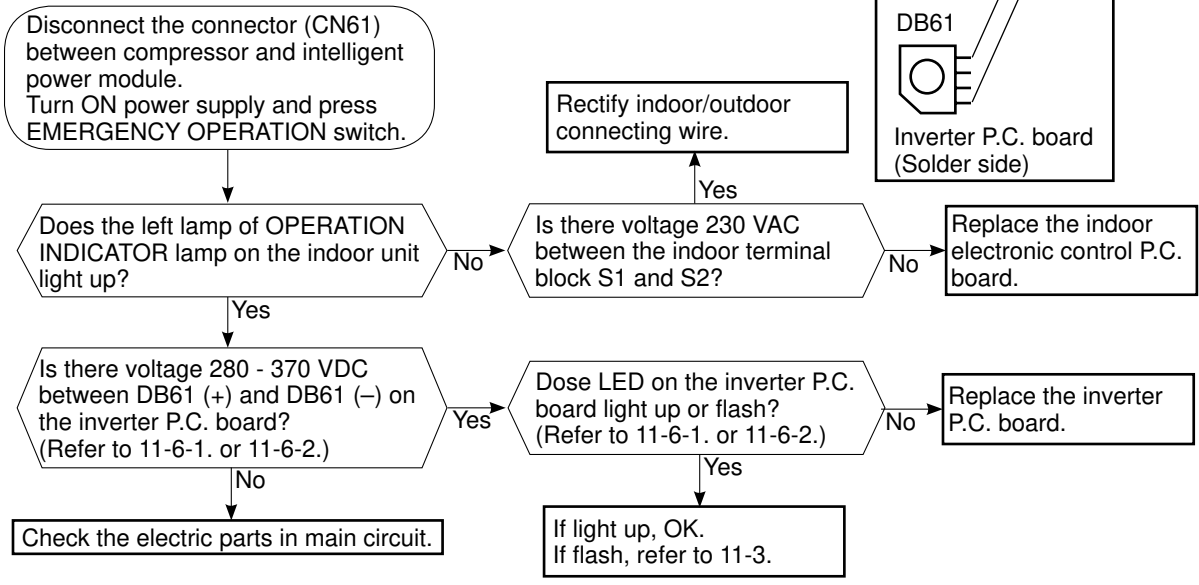

**J Check of LEV** (For wireless remote controller use model)

Turn ON the power supply.  
<Preparation of the remote controller>  
① While pressing both OPERATION SELECT button and TOO COOL button on the remote controller at the same time, press RESET button.  
② First, release RESET button.  
And release the other two buttons after all LCD except the set temperature in operation display section of the remote controller is displayed after 3 seconds.



Press OPERATE/STOP (ON/OFF) button of the remote controller (the set temperature is displayed) with the remote controller headed towards the indoor unit. \*1



Expansion valve operates in full-opening direction.

Do you hear the expansion valve "click, click....." ?  
Do you feel the expansion valve vibrate on touching it ?

\*1. Regardless of normal or abnormal condition, a short beep is emitted once the signal is received.

Is LEV coil properly fixed to the expansion valve? No → Properly fix the LEV coil to the expansion valve.

Yes → Does the resistance of LEV coil have the characteristics? (Refer to 11-4.)  
Yes → Measure each voltage between connector pins of CN724 on the inverter P.C. board.  
1. Pin③(-) — Pin①(+)  
2. Pin④(-) — Pin①(+)  
3. Pin⑤(-) — Pin①(+)  
4. Pin⑥(-) — Pin①(+)  
Is there about 3 ~ 5 VAC between each?  
NOTE: Measure the voltage by an analog tester.  
No → Replace the LEV coil.

Yes → Replace the expansion valve.

**NOTE :** After check of LEV, do the undermentioned operations.  
1. Turn OFF the power supply and turn ON it again.  
2. Press RESET button on the remote controller.

**J Check of LEV** (For wired remote controller use model)

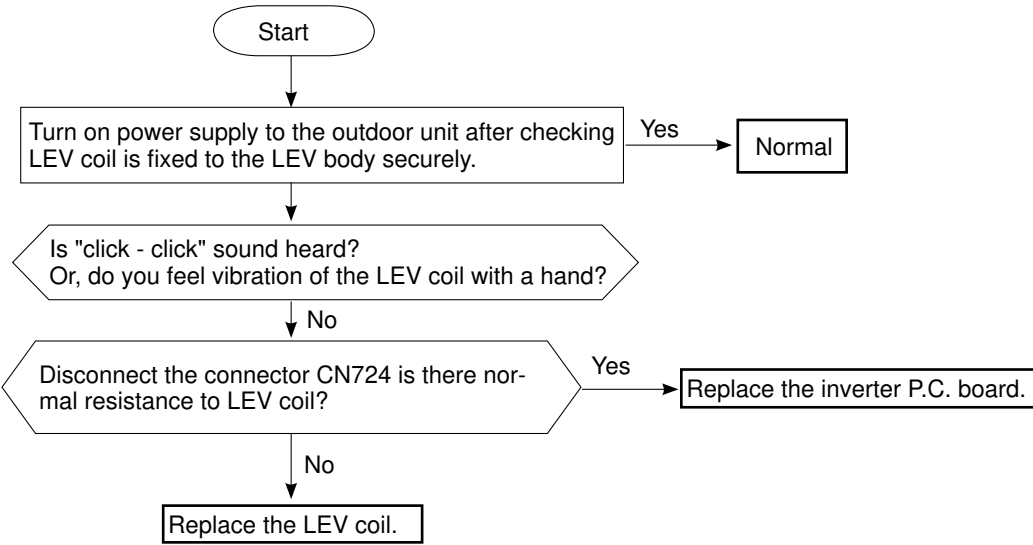

**K Check of inverter P.C. board**

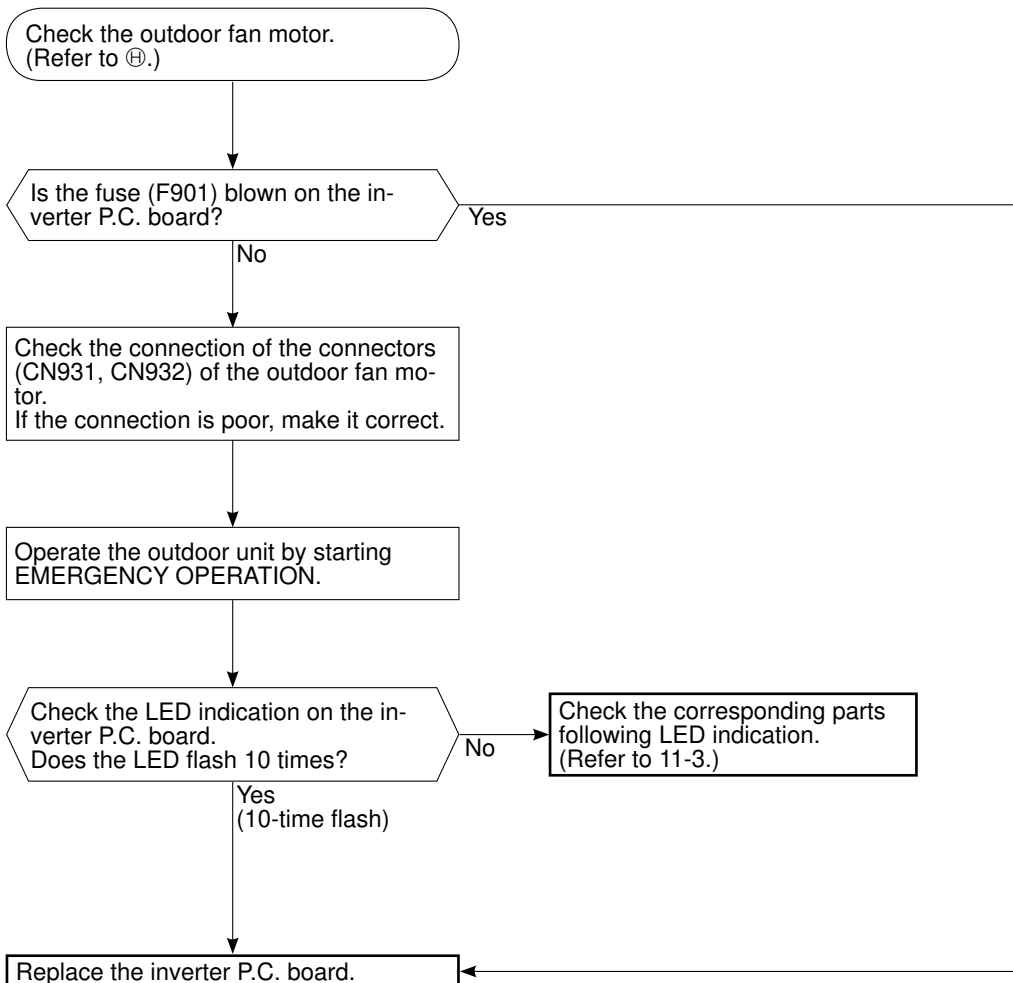

**L How to check miswiring and serial signal error** (For wireless remote controller use model)

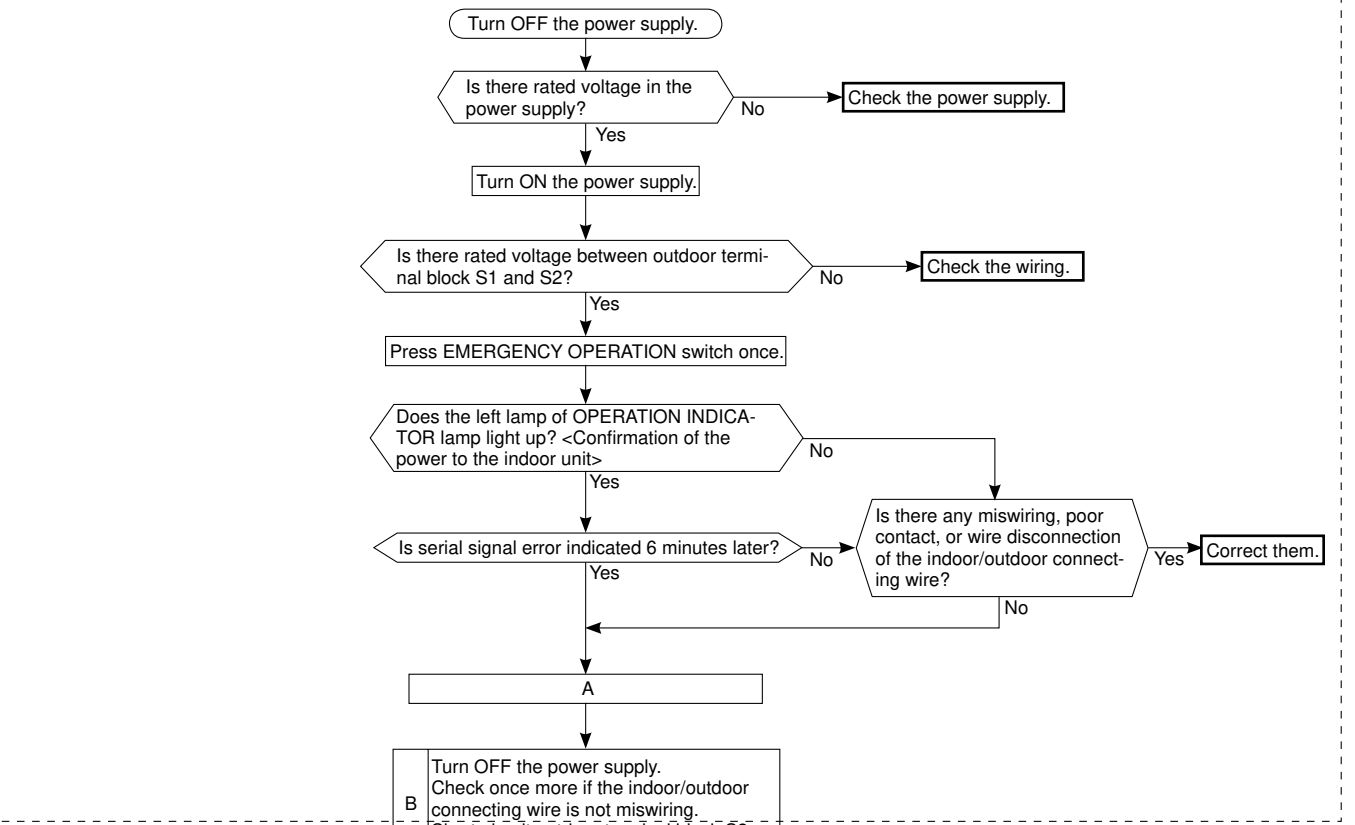

As for indoor unit.

**B**  
Turn OFF the power supply.  
Check once more if the indoor/outdoor connecting wire is not miswiring.  
Short-circuit outdoor terminal block S2 and S3. **※1**

**※1.** Miswiring may damage indoor electronic control P.C. board during the operation. Be sure to confirm the wiring is correct before the operation starts.  
**※3.** Be sure to check this within 3 minutes after turning ON. After 3 minutes, LED blinks 6 times. Even when the inverter P.C. board or the outdoor electronic control P.C. board is normal, LED blinks 6 times after 3 minutes.

Turn ON the power supply.

Does the LED on the inverter P.C. board or the outdoor electronic control P.C. board repeat "3.6-second-OFF and 0.8-second-ON quick blinking"? **※3**

Replace the inverter P.C. board or the outdoor electronic control P.C. board. **※2**  
**※2.** Be careful of the residual voltage of smoothing capacitor.

Turn OFF the power supply.  
Remove the short-circuit between outdoor terminal block S2 and S3.  
Turn ON the power supply.  
Is there amplitude of 10 to 20 VDC between outdoor terminal block S2 and S3? <Confirmation of serial signal>

Is there any error of the indoor/outdoor connecting wire, such as the damage of the wire, intermediate connection, poor contact to the terminal block?  
Yes → Replace the indoor/outdoor connecting wire.

**A**

- Turn OFF inverter-controlled lighting equipment.
- Turn OFF the power supply and then turn ON again.
- Press EMERGENCY OPERATION switch.

Is serial signal error indicated 6 minutes later?

Yes → **B**

No →

- Reinstall either the unit or the light away from each other.
- Attach a filter on remote control receiving section of the indoor unit.

Is there rated voltage between indoor terminal block S1 and S2? <Confirmation of power voltage>

Is there any error of the indoor/outdoor connecting wire, such as the damage of the wire, intermediate connection, poor contact to the terminal block?  
Yes → Replace the indoor/outdoor connecting wire.

Replace the indoor electronic control P.C. board.

Be sure to release the failure-mode recall function after checking.

**Ⓛ How to check miswiring and serial signal error** (For wired remote controller use model)

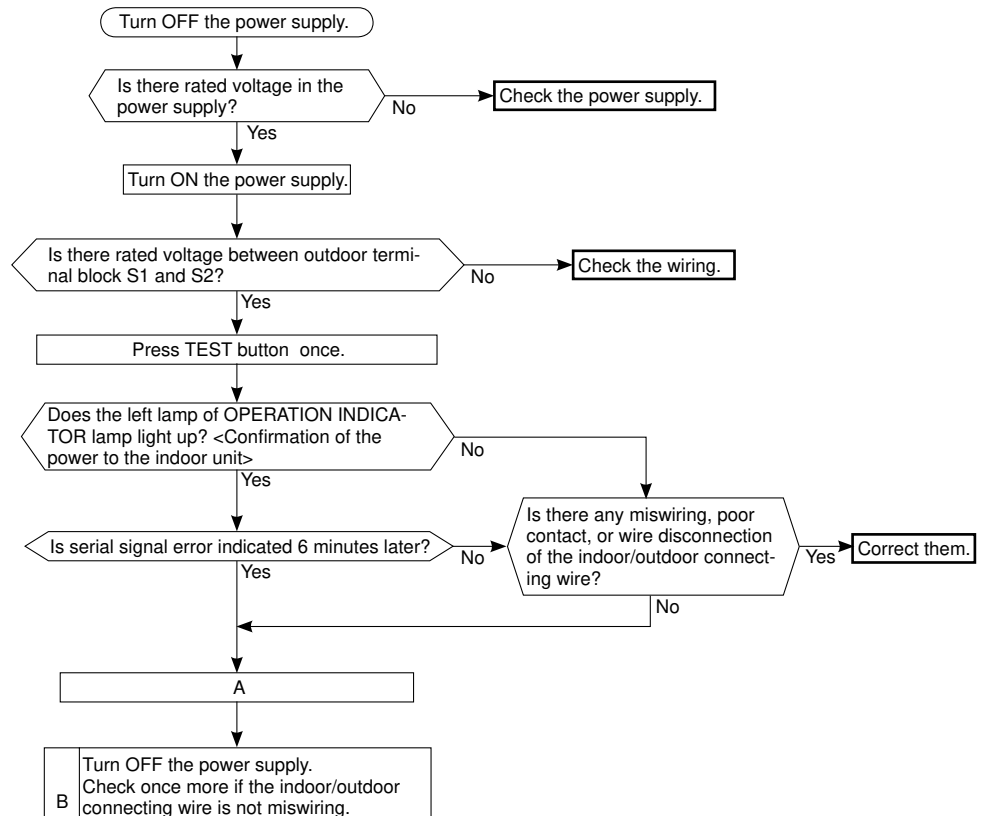

As for indoor unit.

\*1. Miswiring may damage indoor electronic control P.C. board during the operation. Be sure to confirm the wiring is correct before the operation starts.  
 \*2. Be careful of the residual voltage of smoothing capacitor.  
 \*3. Be sure to check this within 3 minutes after turning ON. After 3 minutes, LED blinks 6 times. Even when the inverter P.C. board or the outdoor electronic control P.C. board is normal, LED blinks 6 times after 3 minutes.

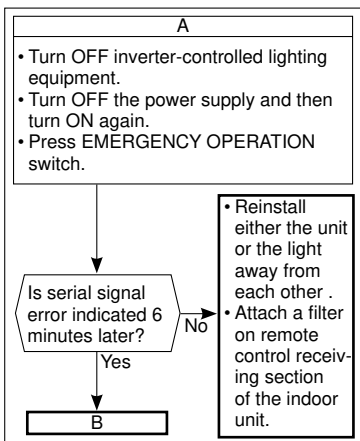

Be sure to release the failure-mode recall function after checking.

**M Electromagnetic noise enters into TV sets or radios**

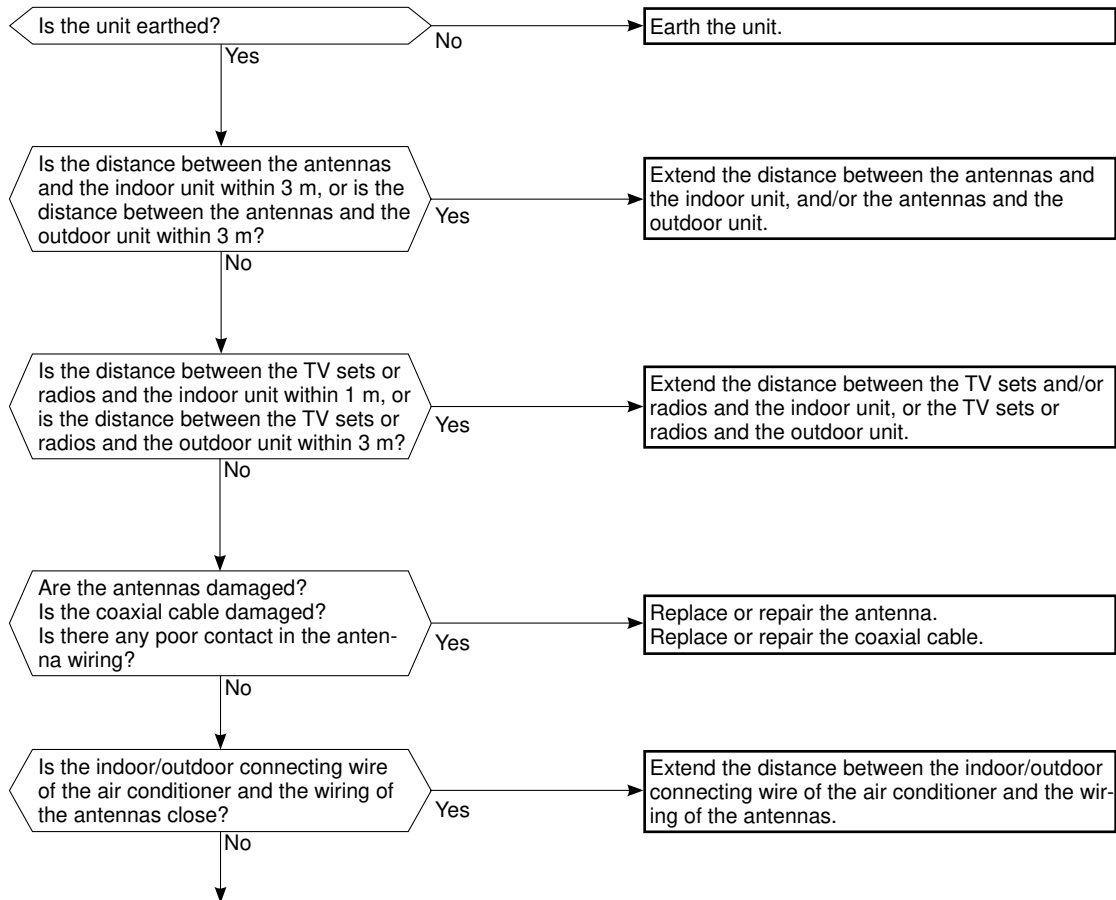

Even if all of the above conditions are fulfilled, the electromagnetic noise may enter, depending on the electric field strength or the installation condition (combination of specific conditions such as antennas or wiring). Check the following before asking for service.

1. Devices affected by the electromagnetic noise  
TV sets, radios (FM/AM broadcast, shortwave)
2. Channel, frequency, broadcast station affected by the electromagnetic noise
3. Channel, frequency, broadcast station unaffected by the electromagnetic noise
4. Layout of ;  
indoor/outdoor unit of the air conditioner, indoor/outdoor wiring, earth wire, antennas, wiring from antennas, receiver
5. Electric field intensity of the broadcast station affected by the electromagnetic noise
6. Presence or absence of amplifier such as booster
7. Operation condition of air conditioner when the electromagnetic noise enters in
  - 1) Turn OFF the power supply once, and then turn ON the power supply. In this situation, check for the electromagnetic noise.
  - 2) Within 3 minutes after turning ON the power supply, press OPERATE/STOP (ON/OFF) button on the remote controller for power ON, and check for the electromagnetic noise.
  - 3) After a short time (3 minutes later after turning ON), the outdoor unit starts running. During operation, check for the electromagnetic noise.
  - 4) Press OPERATE/STOP (ON/OFF) button on the remote controller for power OFF, when the outdoor unit stops but the indoor/outdoor communication still runs on. In this situation, check for the electromagnetic noise.

Outdoor unit does not operate. (LED display: display OFF)

**Ⓝ Check of power supply**

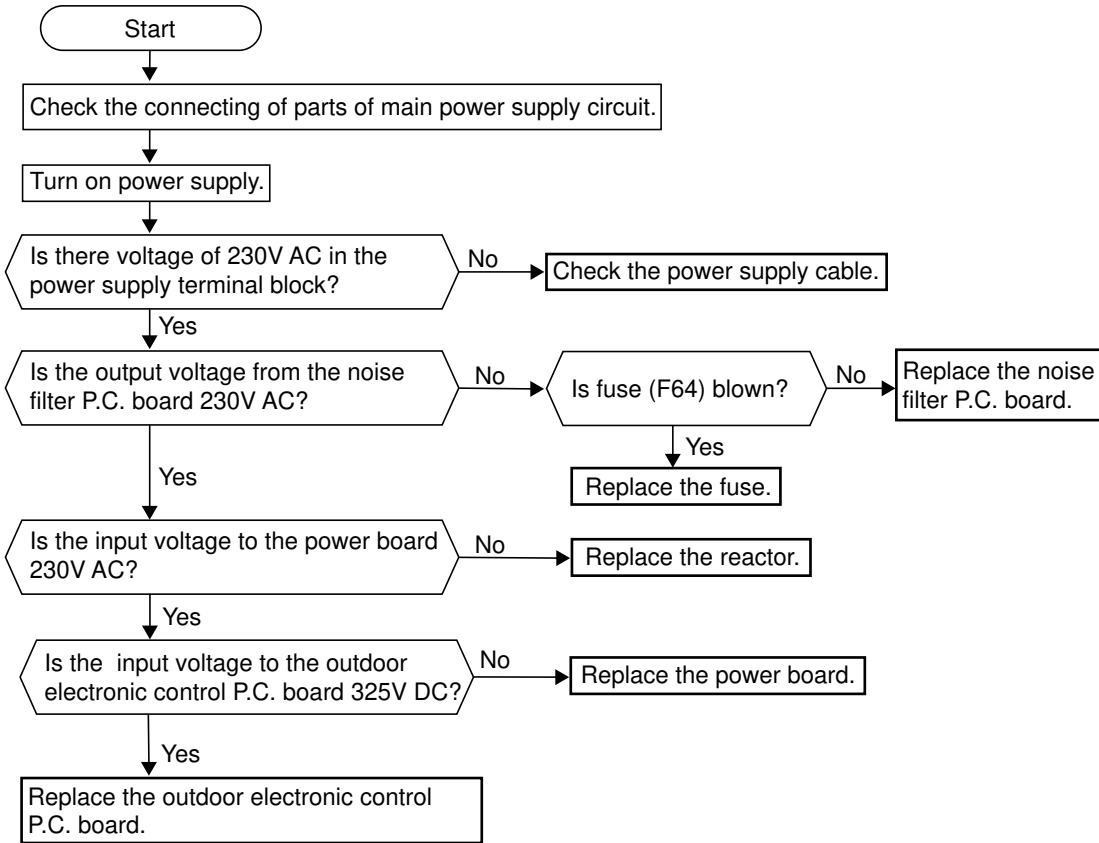

- When unit cannot operate neither by the remote controller nor by EMERGENCY OPERATION switch.  
Indoor unit does not operate.
- Outdoor unit does not operate.

⊙ How to check miswiring and serial signal error (when outdoor unit does not work)

(For wireless remote controller use model)

As for indoor unit.

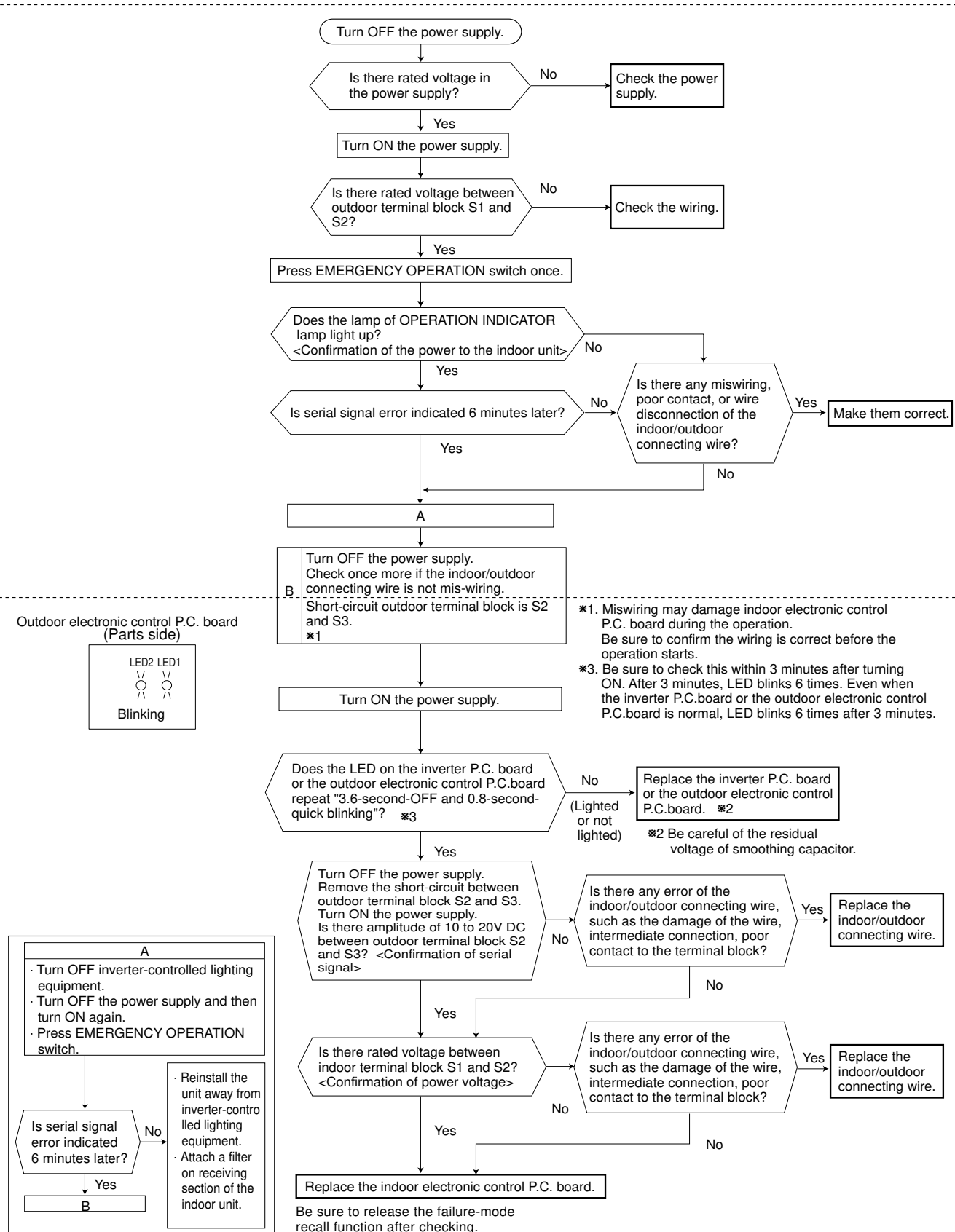

- When unit cannot operate neither by the remote controller.  
Indoor unit does not operate.
- Outdoor unit does not operate.

① How to check miswiring and serial signal error (when outdoor unit does not work)

(For wired remote controller use model)

As for indoor unit.

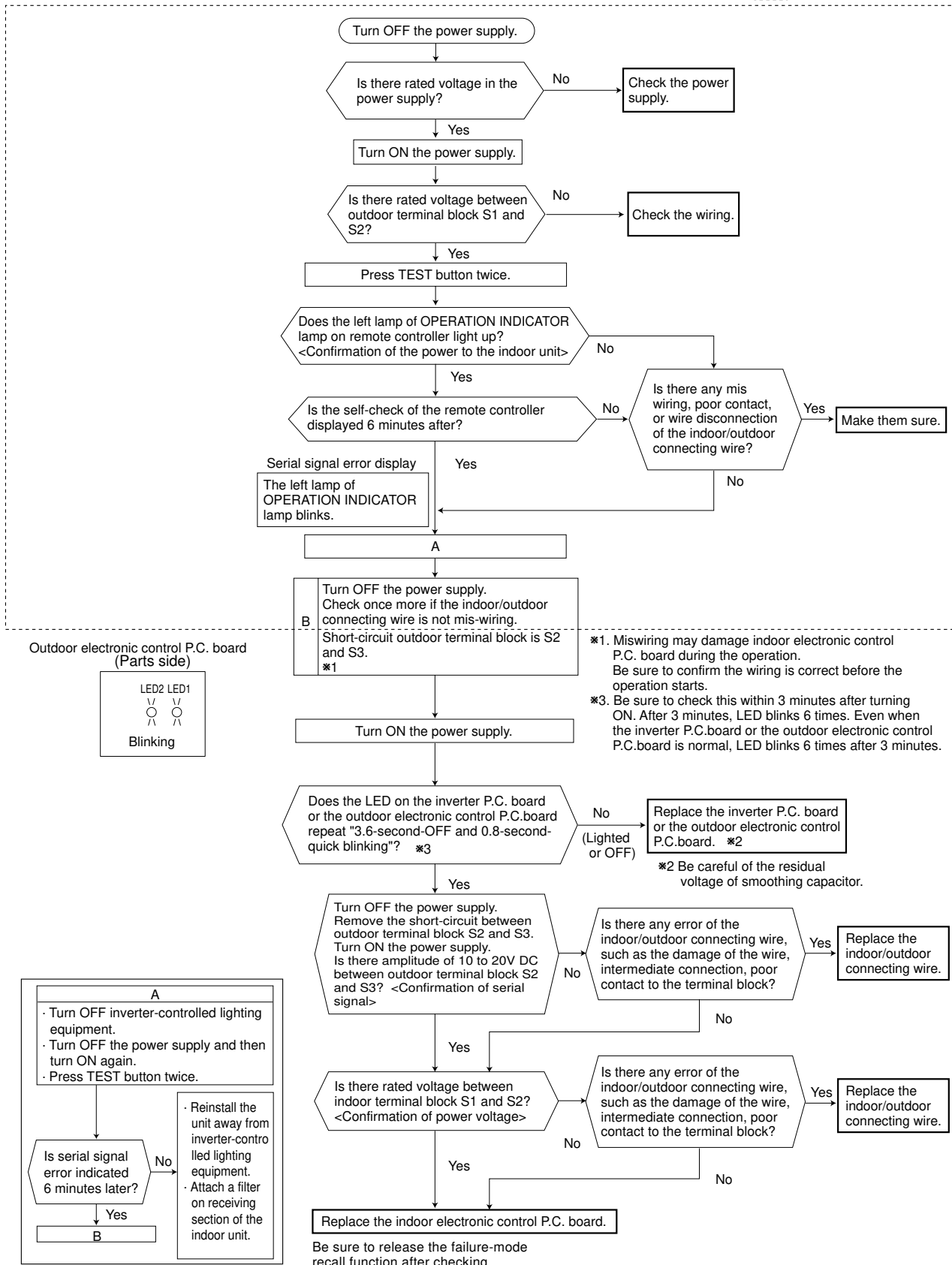

The cooling operation or heating operation does not operate. (LED display: Both LED1 and LED2 lighting)

**P Check of R.V. coil**

**• When heating operation does not work.**

1. Disconnect the lead wire leading to the compressor.
2. 3 minutes after turning on the power supply, start EMERGENCY OPERATION in HEAT mode.

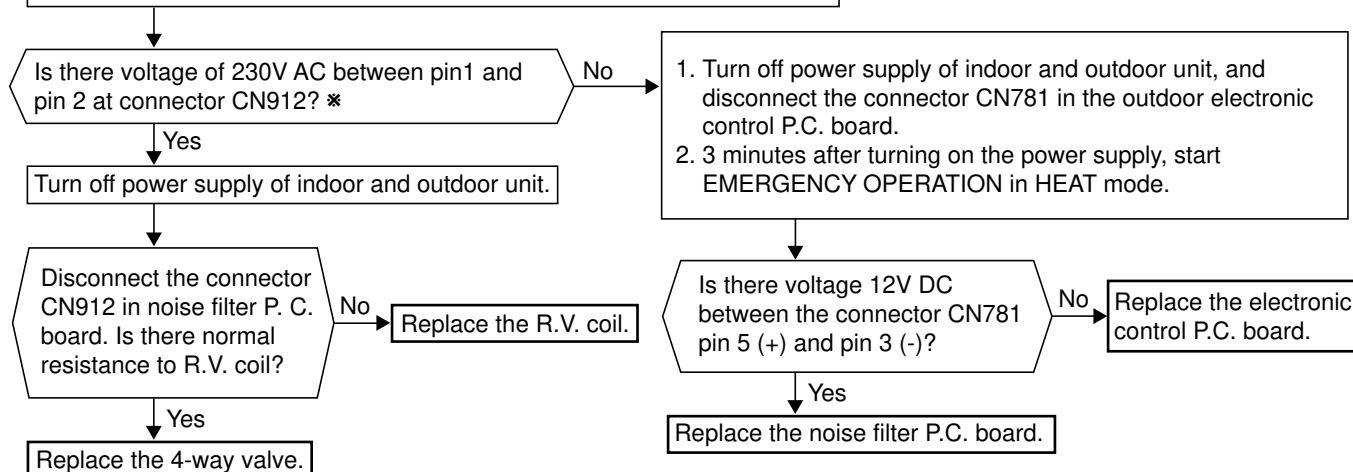

**• When cooling operation does not work.**

1. Disconnect the lead wire leading to the compressor.
2. 3 minutes after turning on the power supply, start EMERGENCY OPERATION in COOL mode.

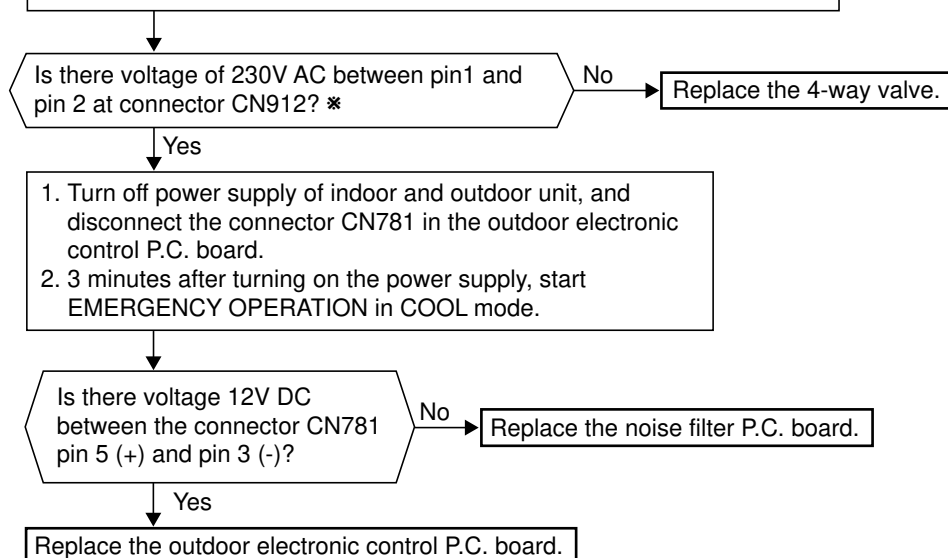

\* If the connector CN912 is not connected or R.V. coil is open, voltage occurs between terminals even when the control is OFF.

- When cooling, heat exchanger of non-operating indoor unit frosts.
- When heating, non-operating indoor unit get warm.

**Q Check of LEV**

LED display:

|          |          |
|----------|----------|
| LED1     | LED2     |
| Lighting | Lighting |
| 6 time   | Goes out |

Turn on power supply to the outdoor unit after checking LEV coil is mounted to the LEV body securely.

Is "click - click" sound heard?  
Or, do you feel vibration of the LEV coil with a hand?

Yes → Normal

No

Disconnect the connector CN795.  
Is there normal resistance to LEV coil?

Yes → Replace the outdoor electronic control P.C. board.

No

Replace the LEV coil.

- When heating, room does not get warm.
- When cooling, room does not get cool.

**R How to check inverter/ compressor**

LED display:

|          |          |
|----------|----------|
| LED1     | LED2     |
| Lighting | Lighting |
| Lighting | Twice    |
| Twice    | Goes out |

Disconnect the terminal of the compressor. 3 minutes after turning on the power supply, start EMERGENCY OPERATION.

Measure the voltage between each lead wire leading to the compressor.  
U (BLK) - V (WHT)  
V (WHT) - W (RED)  
W (RED) - U (BLK)  
Is voltage output on right table?

- \* • After the outdoor fan starts running, wait for 1 minutes or more before measuring the voltage.  
• The output voltage values have the tolerance of ±20%.

| COOL           | HEAT           |
|----------------|----------------|
| 150V<br>(48Hz) | 170V<br>(64Hz) |

Yes

Is output balanced?

No → Replace the power board.

Yes

Is the input voltage to the outdoor electronic control P.C. board 370V or more?

No → Replace the power board.

Yes

Turn off power supply of indoor and outdoor unit, and measure the compressor winding resistance between the compressor terminals.  
Is the resistance between each terminal normal?

No → Replace the compressor.

Yes

Reconnect the lead wire of compressor, and turn on power supply to indoor and outdoor unit.  
3 minutes later, starts EMERGENCY OPERATION.

Clarify the causes by counting time until the inverter stops.  
0 to 10 seconds: compressor rare short  
10 to 60 seconds: compressor lock  
60 seconds to 5minutes: refrigerant circuit defective  
5 minutes or more: normal

• When thermistor is abnormal.

**⑤ Check of outdoor thermistors**

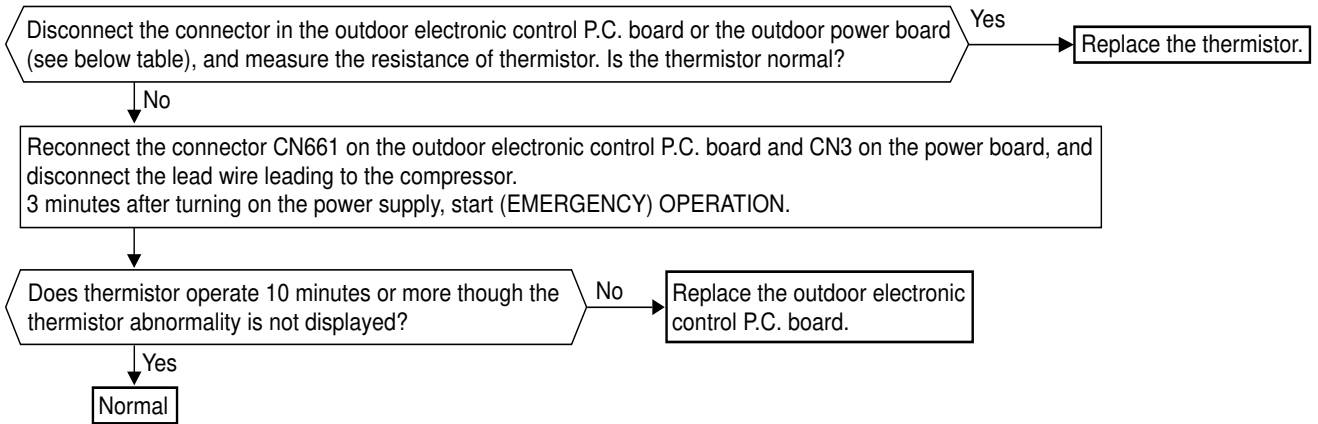

| Thermistor                                    | Symbol | Connector, Pin No.   |
|---|--------|--|
| Defrost thermistor                            | RT61   | Between CN661 pin1 and pin2 on the outdoor electronic control P.C. board |
| Discharge temperature thermistor              | RT62   | Between CN661 pin3 and pin4 on the outdoor electronic control P.C. board |
| Outdoor heat exchanger temperature thermistor | RT68   | Between CN661 pin7 and pin8 on the outdoor electronic control P.C. board |
| Fin temperature thermistor                    | RT64   | Between CN3 pin1 and pin2 on the outdoor power board                     |
| Ambient temperature thermistor                | RT65   | Between CN663 pin1 and pin2 on the outdoor electronic control P.C. board |

• Fan motor does not operate or stops operating shortly after starting the operation.

**⑧ Check of outdoor fan motor**

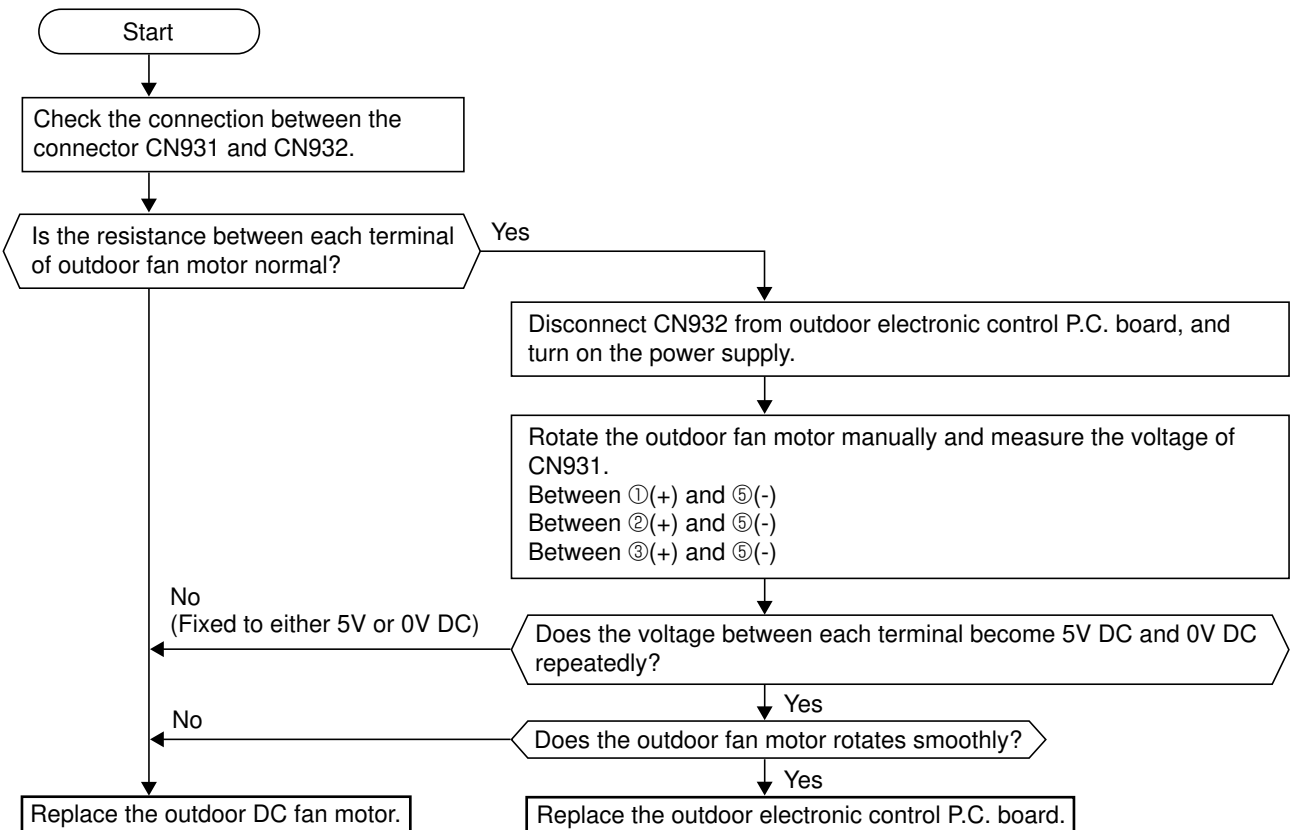

• When the operation frequency does not go up from lowest frequency.

**U Check of HPS**

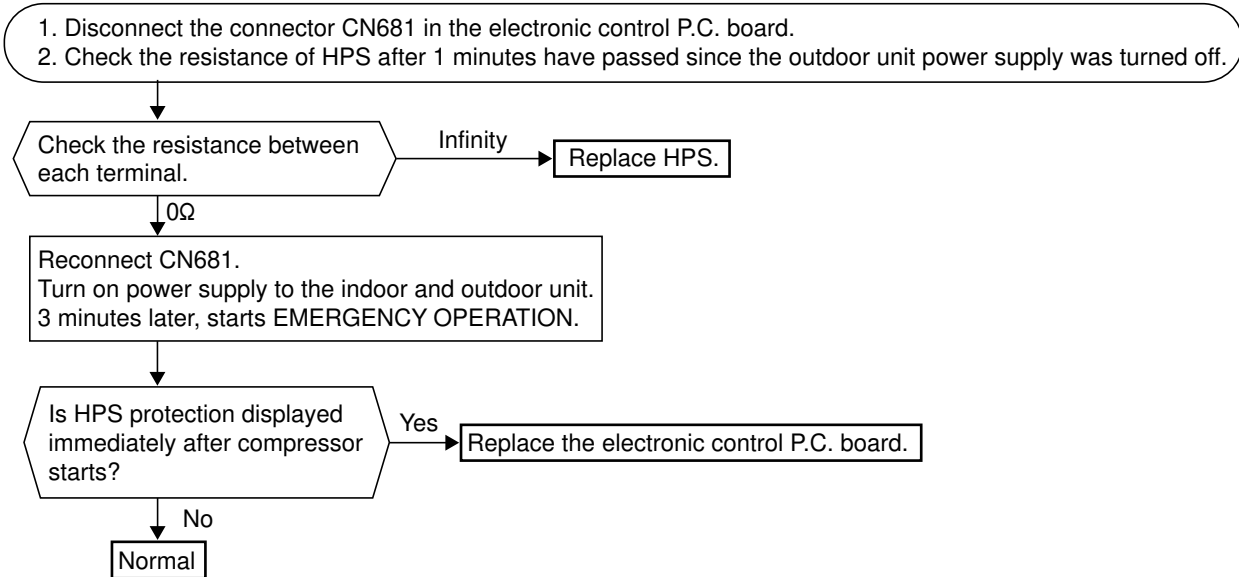

• Outdoor unit does not operate at all, or stops immediately due to overcurrent.

**V Check of current-limiting resistor**

When the current-limiting resistor is open, the rush current limiting relay (X64) may not work properly.

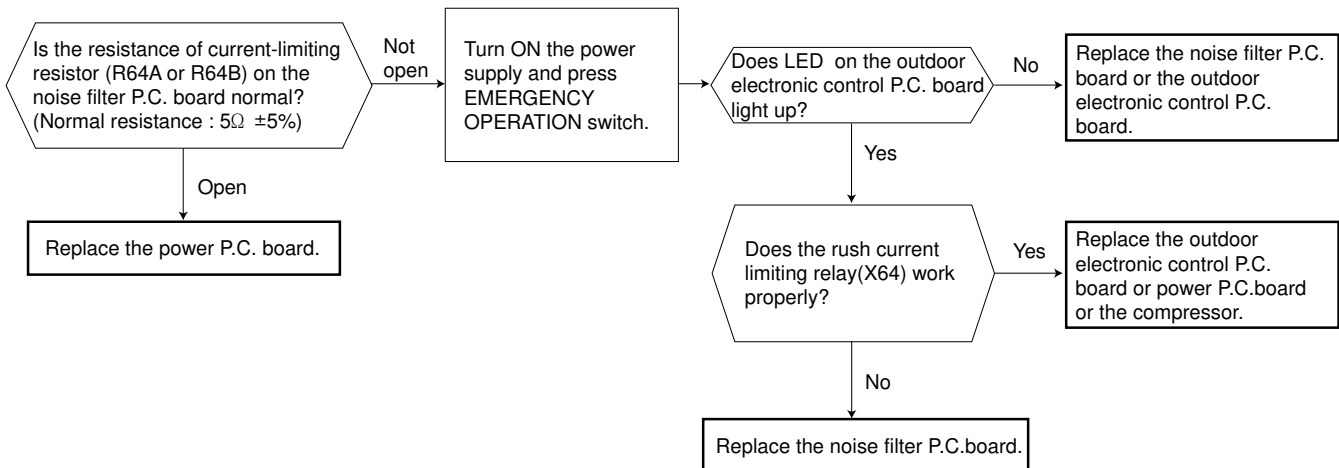

**a) How to check inverter/compressor**

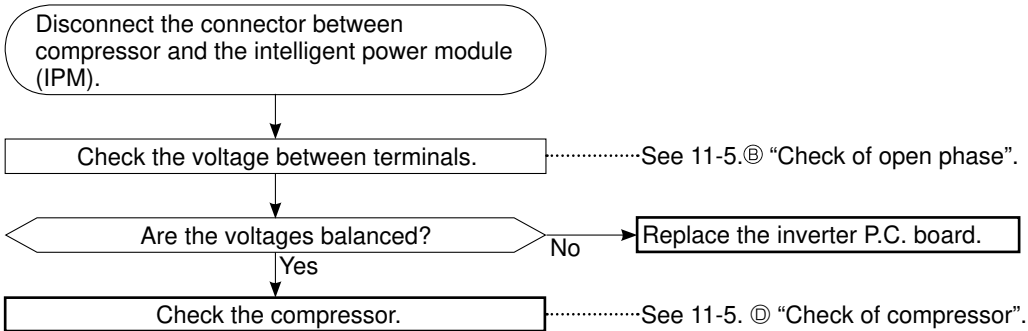

**b) Check of open phase**

- With the connector between the compressor and the intelligent power module disconnected, activate the inverter and check if the inverter is normal by measuring the balance of voltage between the terminals.

Output voltage is 50 - 130 V. (The voltage may differ according to the tester.)

<< Operation method(Test run operation)>>

1. Press EMERGENCY OPERATION switch to start COOL or HEAT mode (COOL: Press once, HEAT: Press twice).
2. Test run operation starts and continues to operate for 30 minutes.
3. Compressor operates at rated frequency in COOL mode or 74 Hz in HEAT mode.
4. Indoor fan operates at High speed.
5. After 30 minutes, test run operation finishes and EMERGENCY OPERATION starts (operation frequency of compressor varies).
6. To cancel test run operation (EMERGENCY OPERATION), press EMERGENCY OPERATION switch or any button on remote controller.

<<Measurement point>>

- At 3 points
- BLK (U)-WHT (V)      ※ Measure AC voltage between the lead wires at 3 points.
- BLK (U)-RED (W)
- WHT(V)-RED (W)

- NOTE:**
1. Output voltage varies according to power supply voltage.
  2. Measure the voltage by analog type tester.
  3. During this check, LED of the inverter P.C. board flashes 9 times. (Refer to 11-6.3.)

**c) Check of compressor**

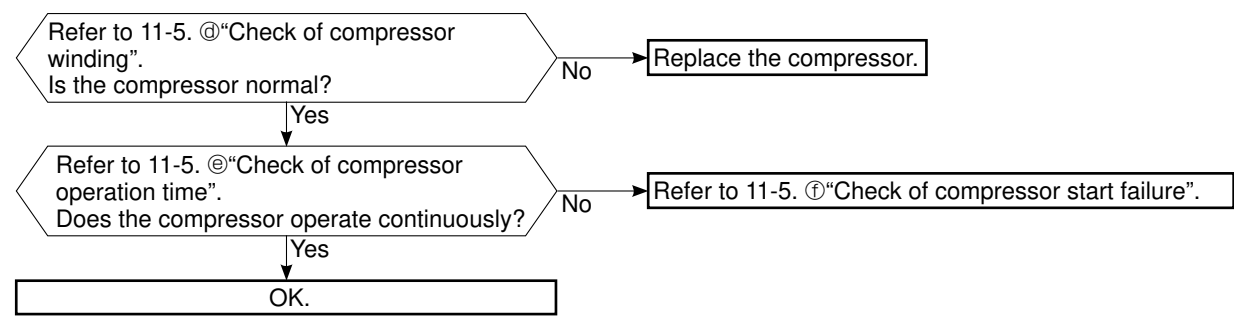

**d Check of compressor winding**

• Disconnect the connector between the compressor and intelligent power module, and measure the resistance between the compressor terminals.

<<Measurement point>>

at 3 points

BLK-WHT

BLK-RED

WHT-RED

※ Measure the resistance between the lead wires at 3 points.

<<Judgement>>

Refer to 11-4.

0 [Ω] .....Abnormal [short]

Infinite [Ω] .....Abnormal [open]

**NOTE:** Be sure to zero the ohmmeter before measurement.

**e Check of compressor operation time**

• Connect the compressor and activate the inverter. Then measure the time until the inverter stops due to over current.

<<Operation method>>

Start heating or cooling operation by pressing EMERGENCY OPERATION switch on the indoor unit. (TEST RUN OPERATION: Refer to 11-5 ⑥.)

<<Measurement>>

Measure the time from the start of compressor to the stop of compressor due to overcurrent.

<<Judgement>>

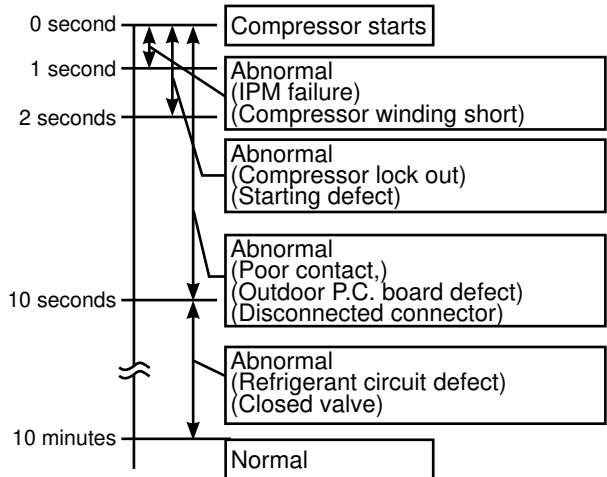

**f Check of compressor start failure**

Confirm that ①~④ is normal.

•Electrical circuit check

①. Contact of the compressor connector

②. Output voltage of inverter P.C. board and balance of them (See 11-5 ⑥.)

③. Direct current voltage between JP715(+) and JP30(-) on the inverter P.C.board

④. Voltage between outdoor terminal block S1-S2

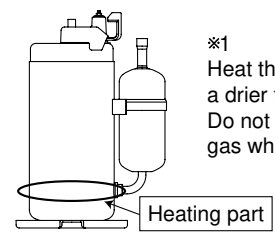
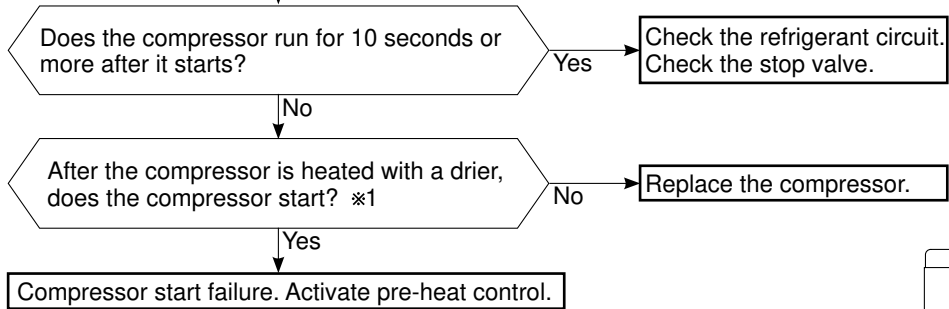

※1 Heat the compressor with a drier for about 20 minutes. Do not recover refrigerant gas while heating.

**g Check of outdoor thermistors**

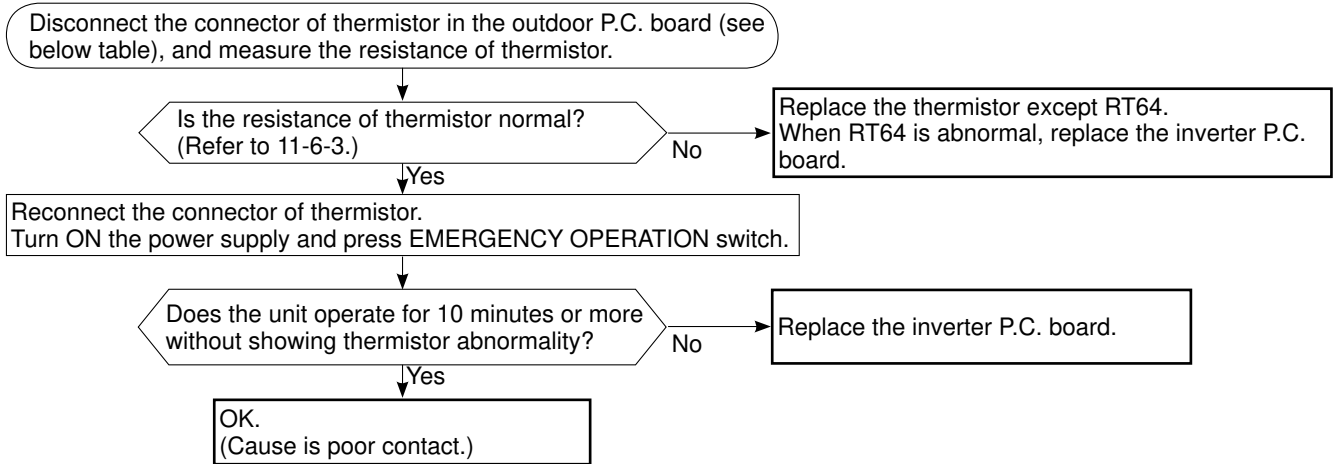

| Thermistor                         | Symbol | Connector, Pin No.          | Board               |
|------------------------------------|--------|-----------------------------|---------------------|
| Defrost                            | RT61   | Between CN671 pin1 and pin2 | Inverter P.C. board |
| Discharge temperature              | RT62   | Between CN671 pin3 and pin4 |                     |
| Fin temperature                    | RT64   | Between CN673 pin1 and pin2 |                     |
| Ambient temperature                | RT65   | Between CN672 pin1 and pin2 |                     |
| Outdoor heat exchanger temperature | RT68   | Between CN671 pin5 and pin6 |                     |

**h Check of R.V. coil**

- \* First of all, measure the resistance of R.V. coil to check if the coil is defective. Refer to 11-4.
- \* In case CN602 is disconnected or R.V. coil is open, voltage is generated between the terminal pins of the connector although no signal is being transmitted to R.V. coil. Check if CN602 is connected.

**Unit operates COOL mode even if it is set to HEAT mode.**

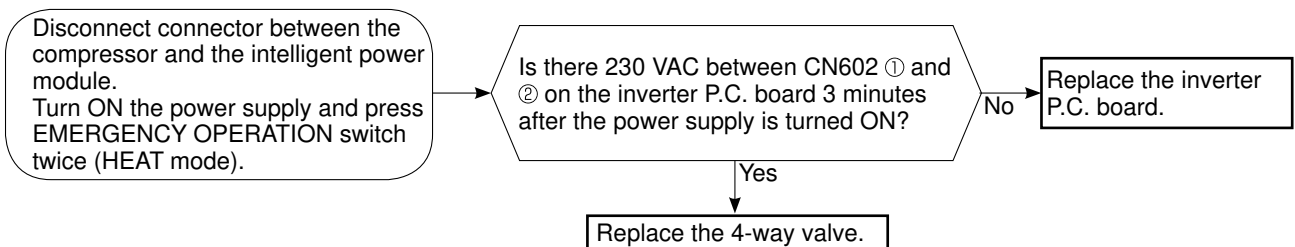

**Unit operates HEAT mode even if it is set to COOL mode.**

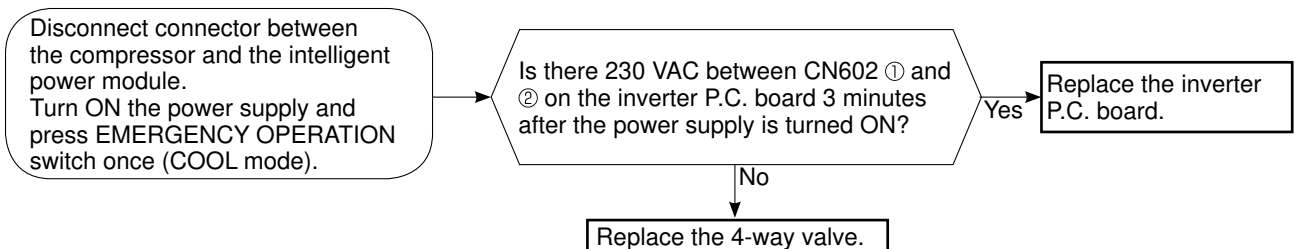

**i Check of outdoor fan motor**

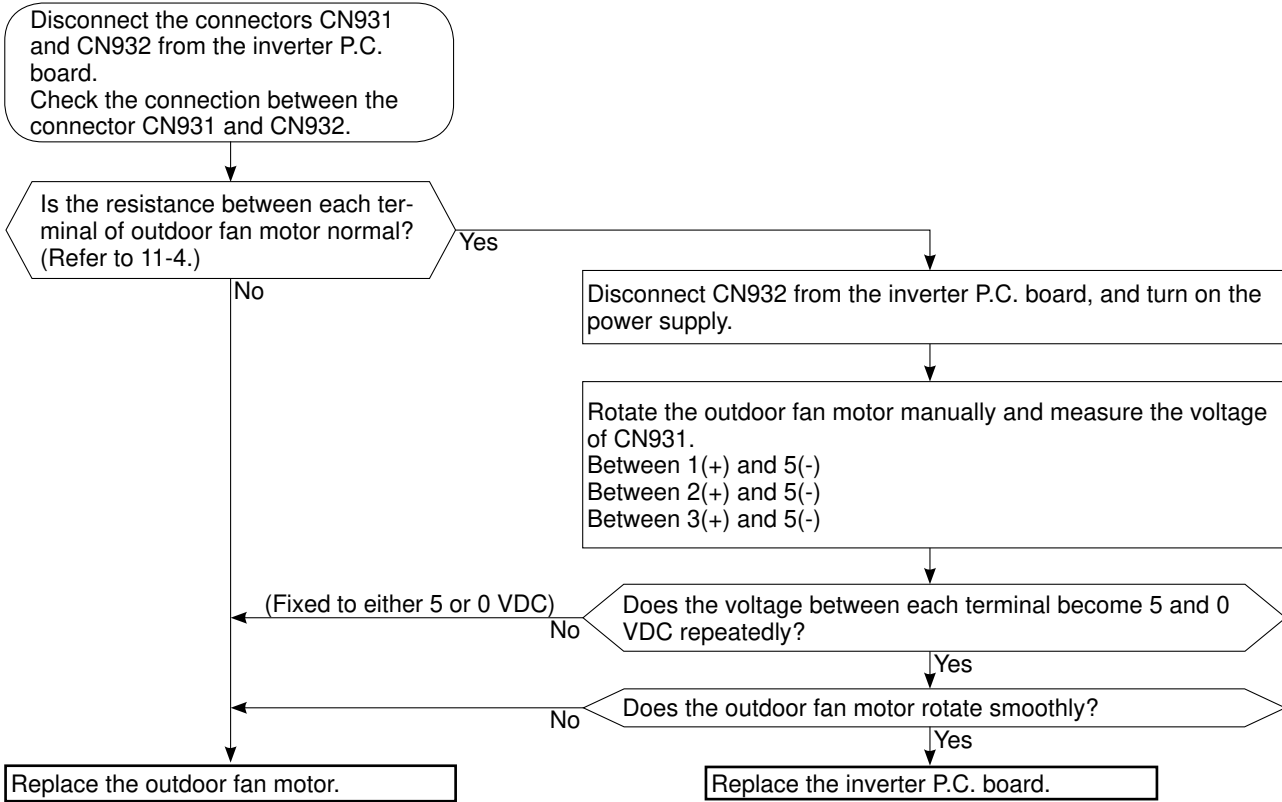

**j Check of power supply**

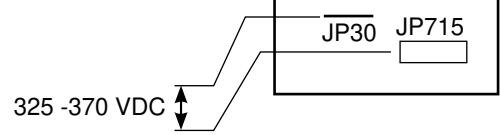
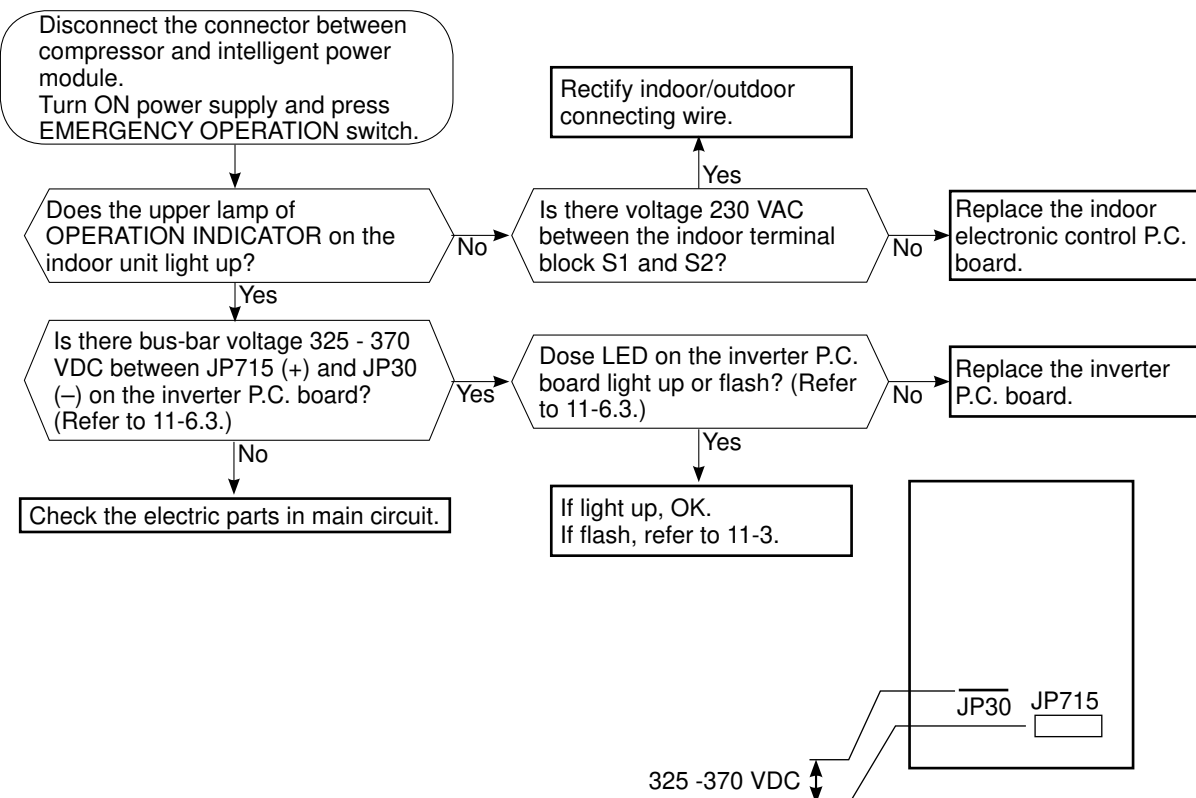

**K Check of LEV** (For wireless remote controller use model)

Turn ON the power supply.  
 <Preparation of the remote controller>  
 ① While pressing both OPERATION SELECT button and TOO COOL button on the remote controller at the same time, press RESET button.  
 ② First, release RESET button.  
 And release the other two buttons after all LCD except the set temperature in operation display section of the remote controller is displayed after 3 seconds.



Press OPERATE/STOP (ON/OFF) button of the remote controller (the set temperature is displayed) with the remote controller headed towards the indoor unit. ※1

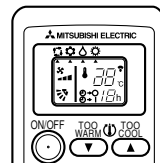

Expansion valve operates in full-opening direction.

Do you hear the expansion valve "click, click....." ?  
 Do you feel the expansion valve vibrate on touching it ?

※1. Regardless of normal or abnormal condition, a short beep is emitted once the signal is received.

Is LEV coil properly fixed to the expansion valve?

Does the resistance of LEV coil have the characteristics? (Refer to 11-4.)

Measure each voltage between connector pins of CN724 on the inverter P.C. board.  
 1. Pin③(-) — Pin①(+)  
 2. Pin④(-) — Pin①(+)  
 3. Pin⑤(-) — Pin①(+)  
 4. Pin⑥(-) — Pin①(+)  
 Is there about 3 - 5 VAC between each?  
**NOTE:** Measure the voltage by an analog tester.

Replace the LEV coil.

Properly fix the LEV coil to the expansion valve.

Replace the inverter P.C. board.

Replace the expansion valve.

**NOTE:** After check of LEV, do the undermentioned operations.  
 1. Turn OFF the power supply and turn it ON again.  
 2. Press RESET button on the remote controller.

**K Check of LEV** (For wired remote controller use model)

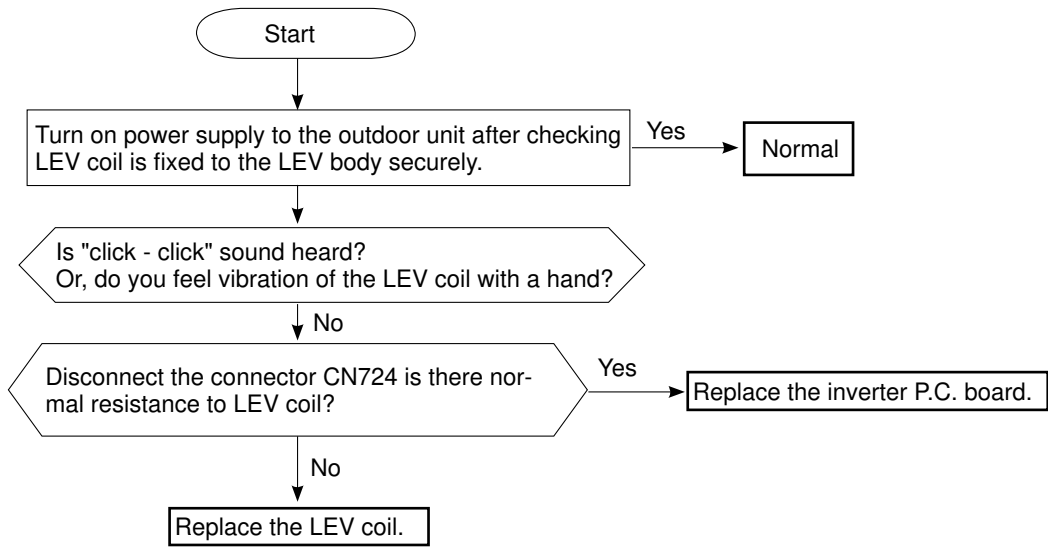

**① Check of inverter P.C. board**

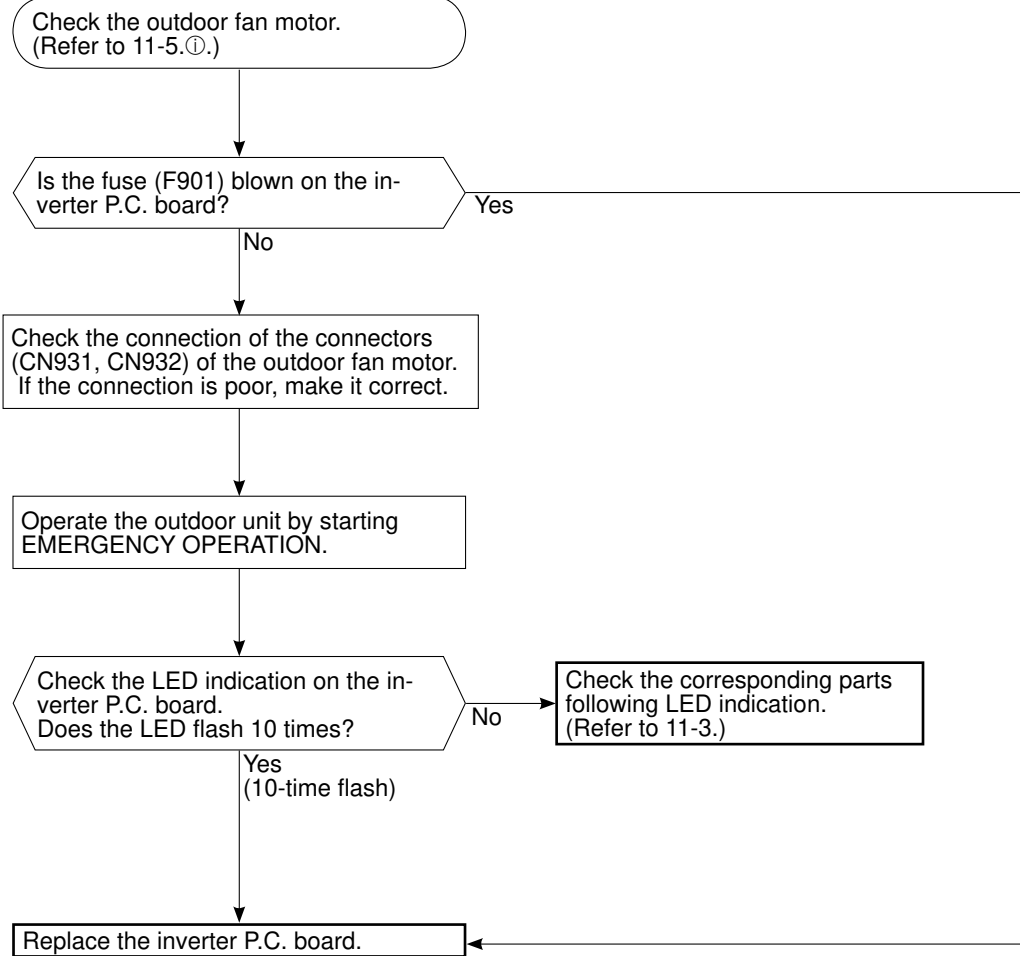

**m How to check miswiring and serial signal error**

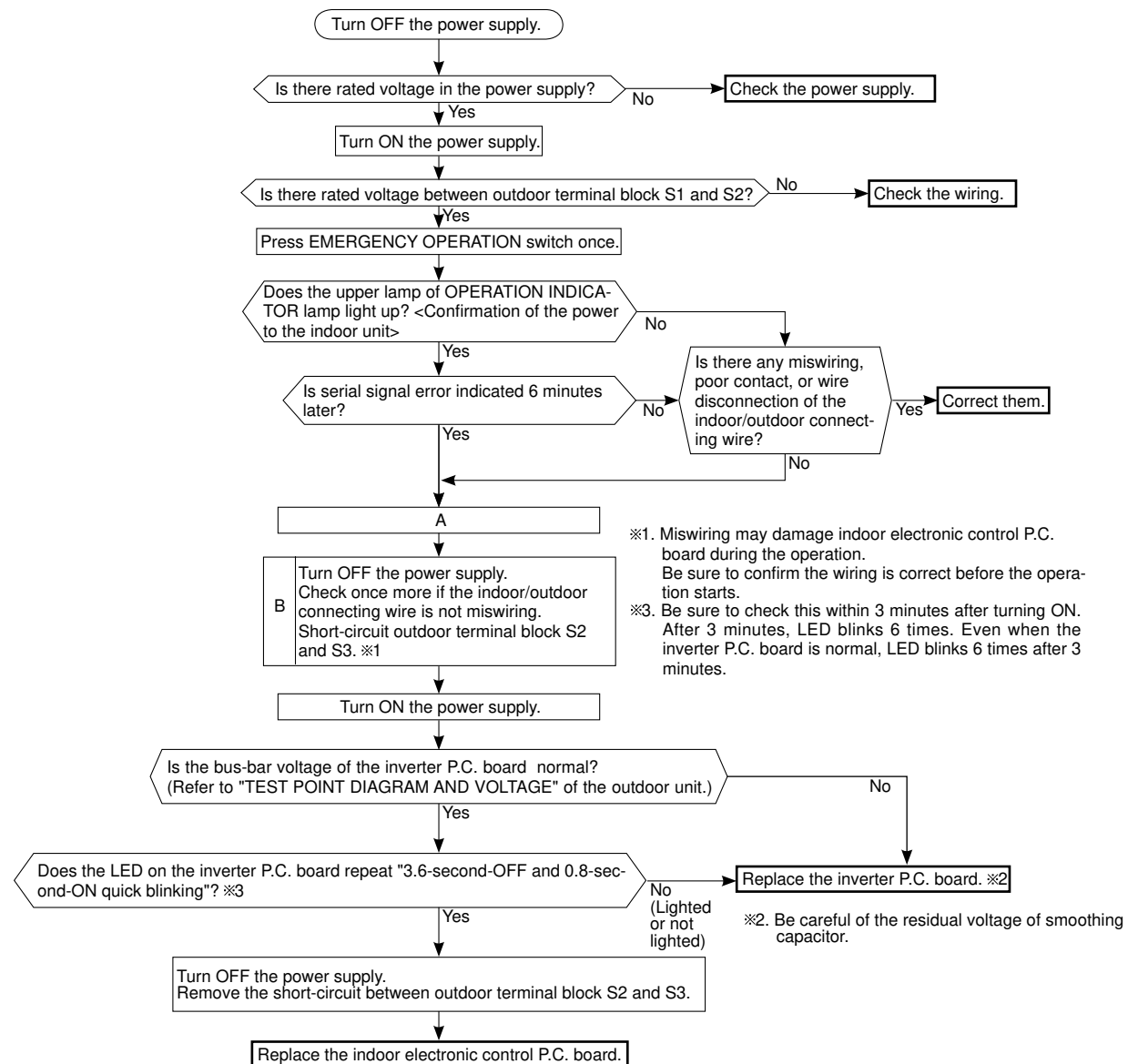

※1. Miswiring may damage indoor electronic control P.C. board during the operation. Be sure to confirm the wiring is correct before the operation starts.  
 ※3. Be sure to check this within 3 minutes after turning ON. After 3 minutes, LED blinks 6 times. Even when the inverter P.C. board is normal, LED blinks 6 times after 3 minutes.

※2. Be careful of the residual voltage of smoothing capacitor.

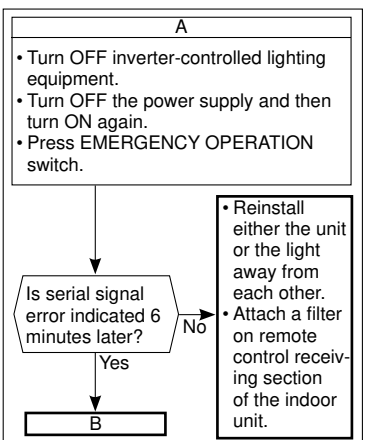

## n Electromagnetic noise enters into TV sets or radios

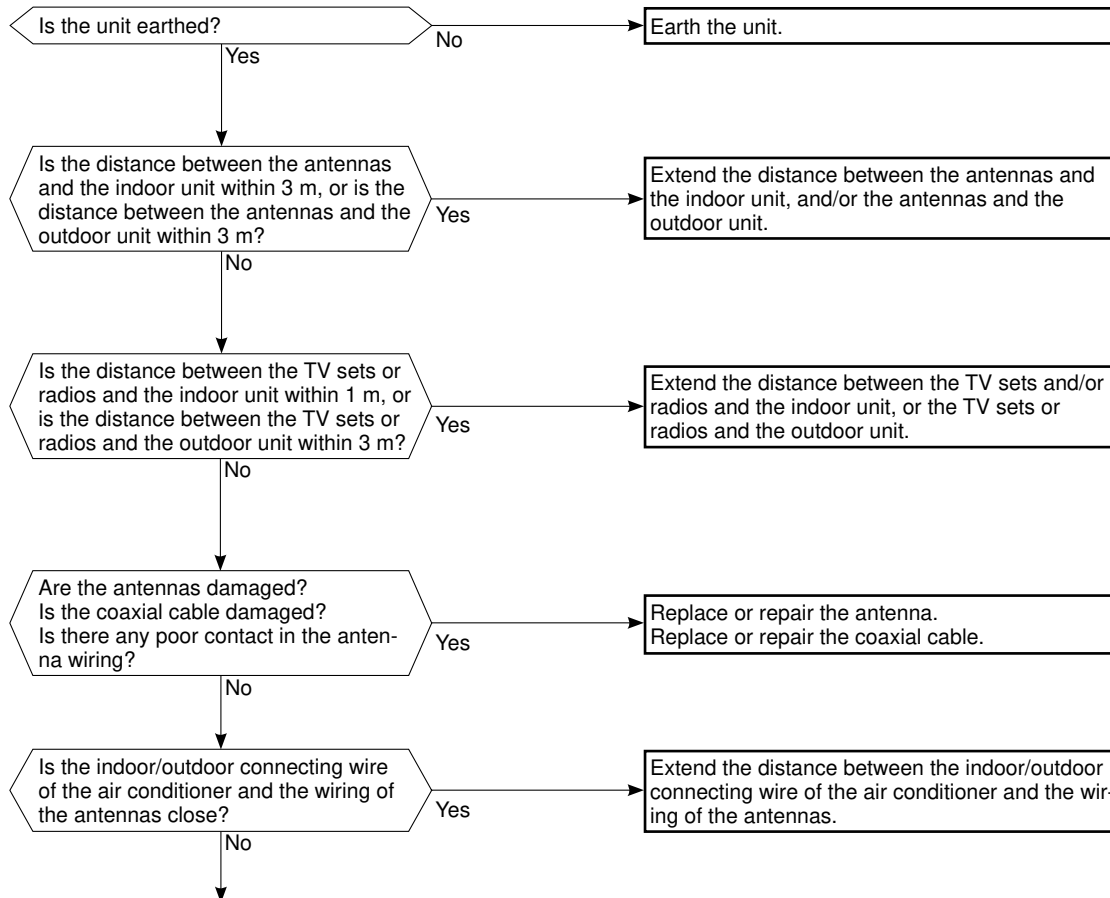

Even if all of the above conditions are fulfilled, the electromagnetic noise may enter, depending on the electric field strength or the installation condition (combination of specific conditions such as antennas or wiring).

Check the following before asking for service.

1. Devices affected by the electromagnetic noise  
TV sets, radios (FM/AM broadcast, shortwave)
2. Channel, frequency, broadcast station affected by the electromagnetic noise
3. Channel, frequency, broadcast station unaffected by the electromagnetic noise
4. Layout of:  
indoor/outdoor unit of the air conditioner, indoor/outdoor wiring, earth wire, antennas, wiring from antennas, receiver
5. Electric field intensity of the broadcast station affected by the electromagnetic noise
6. Presence or absence of amplifier such as booster
7. Operation condition of air conditioner when the electromagnetic noise enters in
  - 1) Turn OFF the power supply once, and then turn ON the power supply. In this situation, check for the electromagnetic noise.
  - 2) Within 3 minutes after turning ON the power supply, press OPERATE/STOP (ON/OFF) button on the remote controller for power ON, and check for the electromagnetic noise.
  - 3) After a short time (3 minutes later after turning ON), the outdoor unit starts running. During operation, check for the electromagnetic noise.
  - 4) Press OPERATE/STOP (ON/OFF) button on the remote controller for power OFF, when the outdoor unit stops but the indoor/outdoor communication still runs on. In this situation, check for the electromagnetic noise.

## 11-6. Test point diagram and voltage

### 11-6-1. Inverter P.C. board

#### SUZ-KA25VA2.TH SUZ-KA35VA2.TH

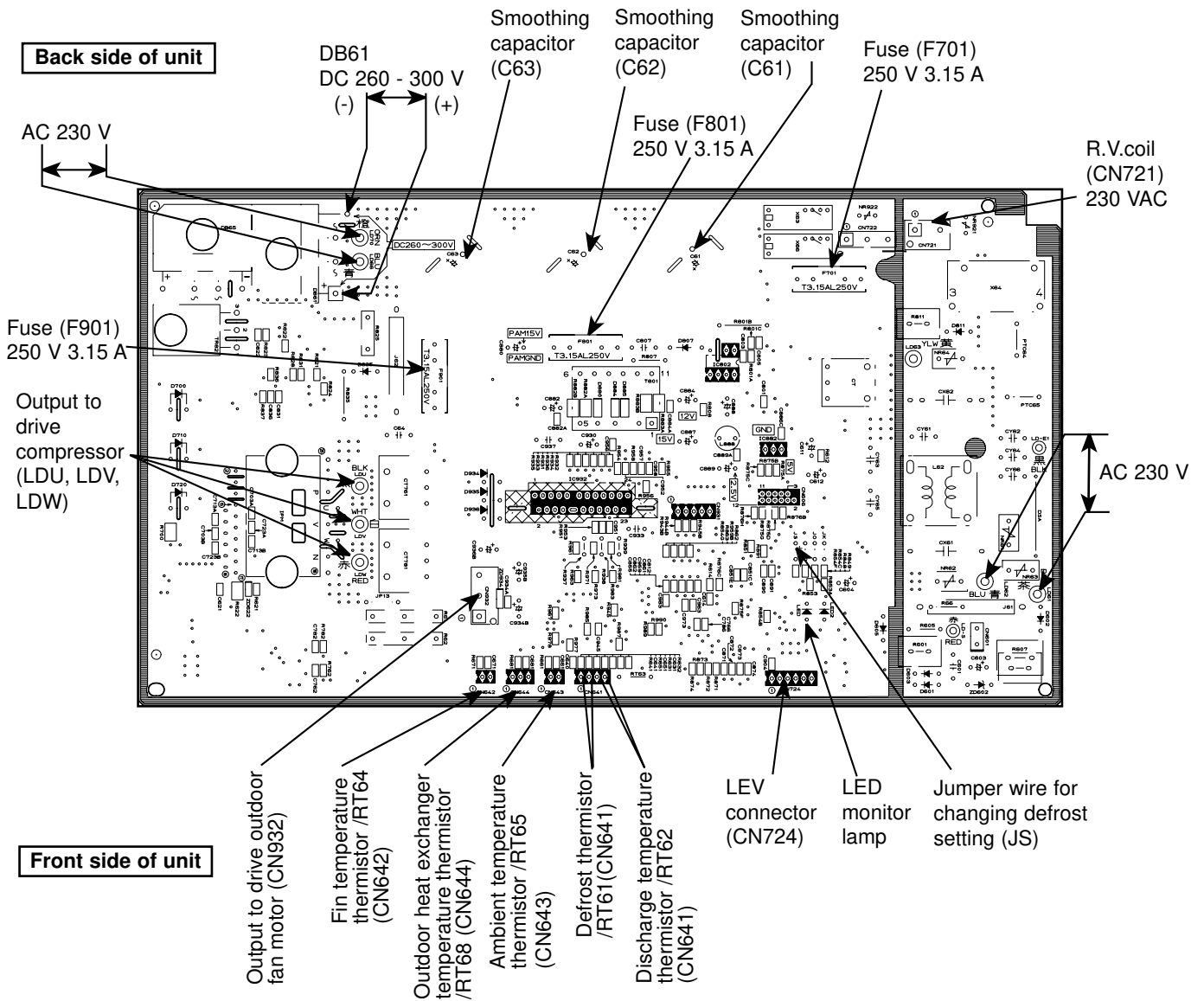

Defrost thermistor (RT61)  
Ambient temperature thermistor (RT65)  
Outdoor heat exchanger temperature thermistor (RT68)

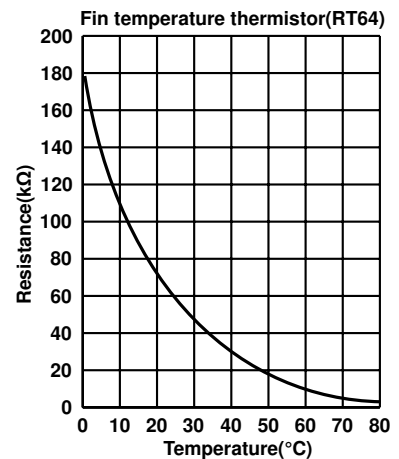
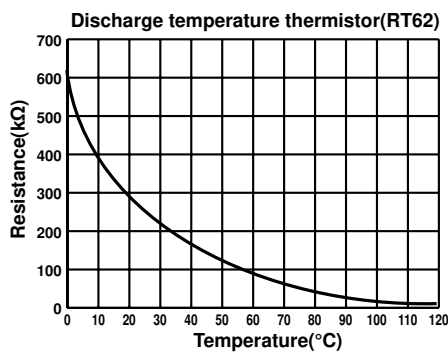
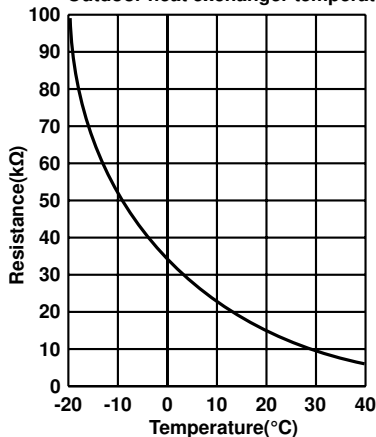

# 11-6-2. Inverter P.C. board SUZ-KA50VA2.TH

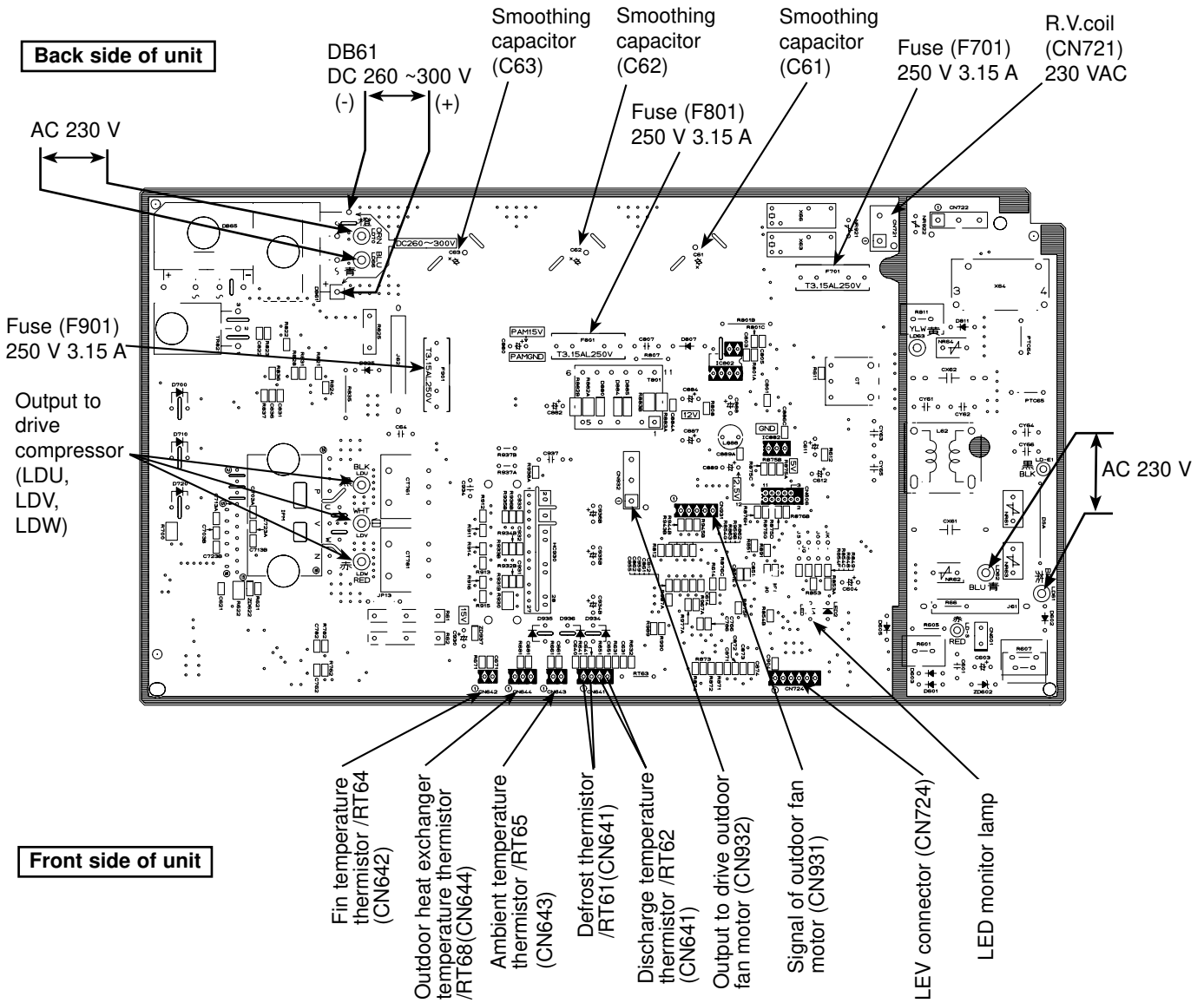

Defrost thermistor (RT61)  
Ambient temperature thermistor (RT65)  
Outdoor heat exchanger temperature thermistor (RT68)

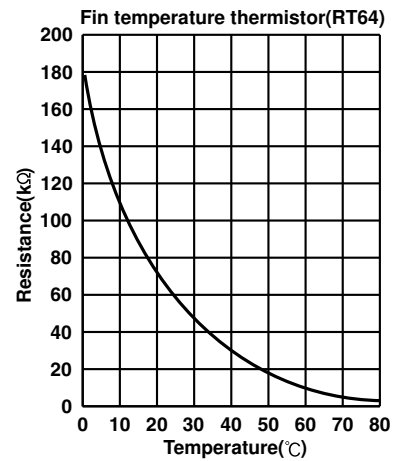
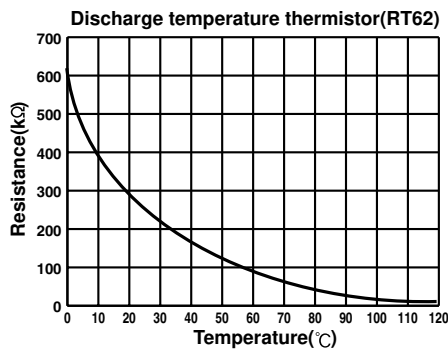
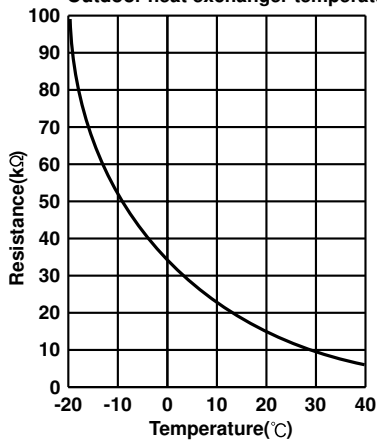

### 11-6-3. Inverter P.C. board SUZ-KA71VA2.TH

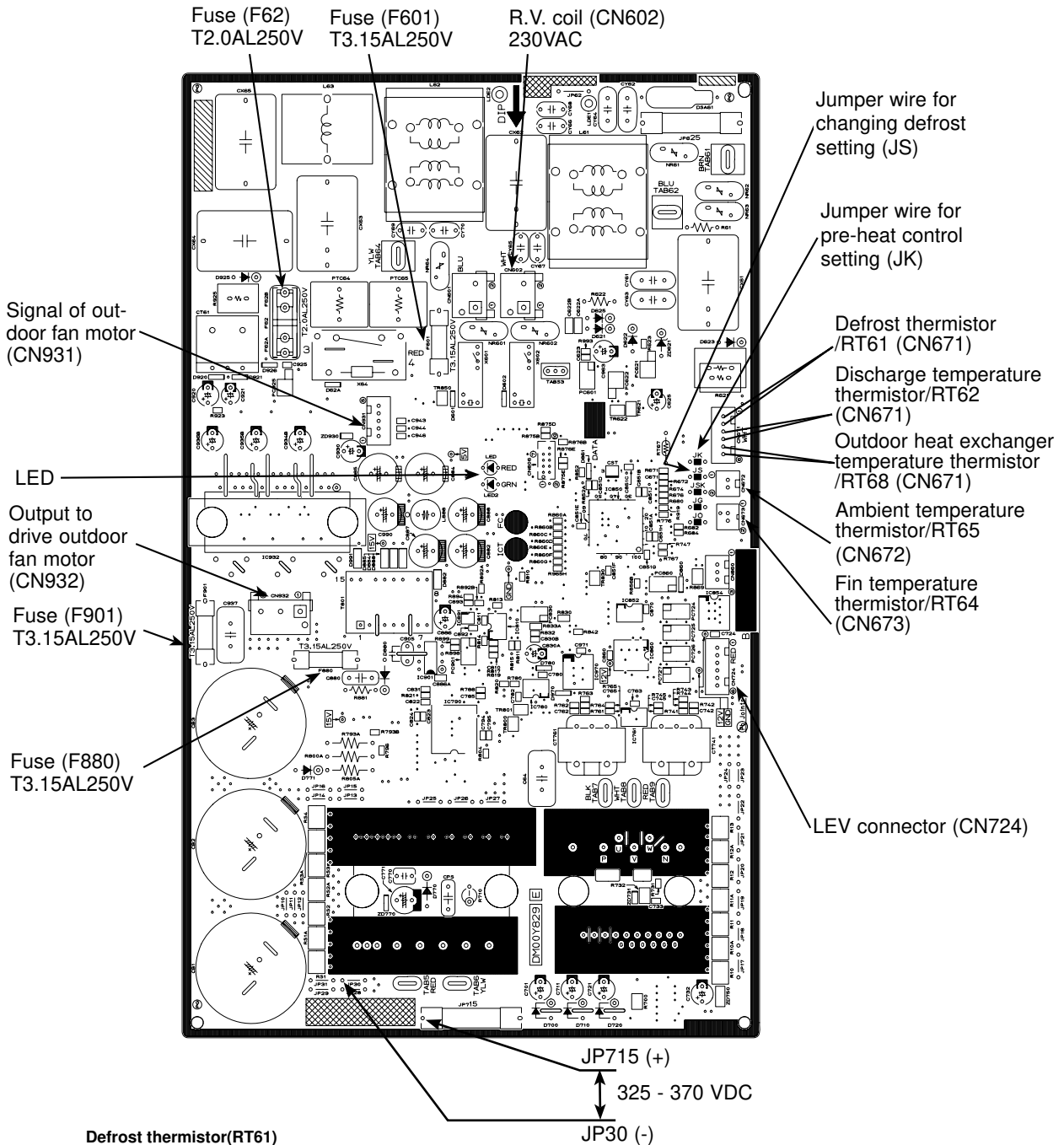

Defrost thermistor (RT61)  
 Ambient temperature thermistor (RT65)  
 Outdoor heat exchanger temperature thermistor (RT68)

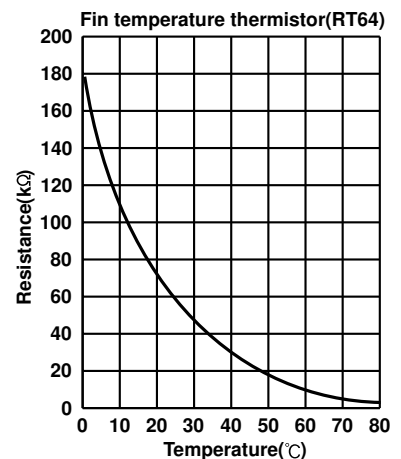
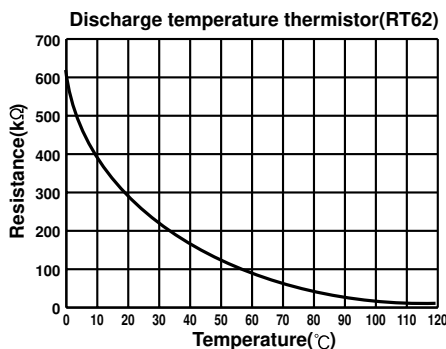
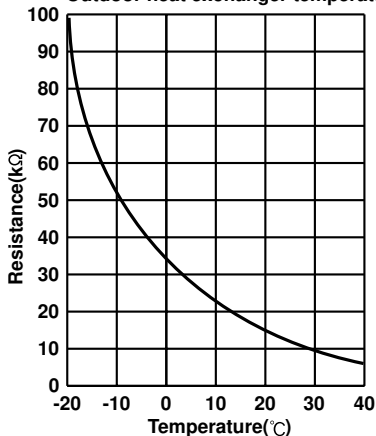

# 11-6-4. Outdoor electronic control P.C. board SUZ-KA60VA2.TH

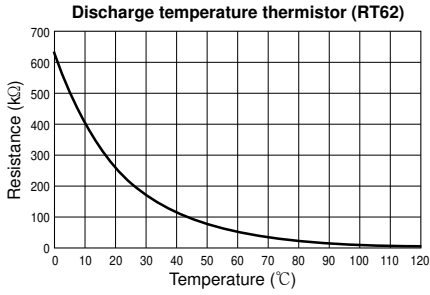

Defrost thermistor (RT61)  
Ambient temperature thermistor (RT65)  
Outdoor heat exchanger temperature thermistor (RT66)

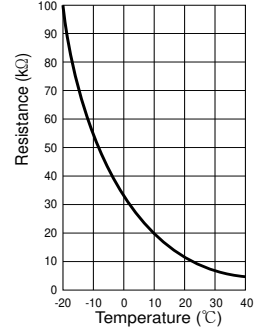

Fin temperature thermistor (RT64)

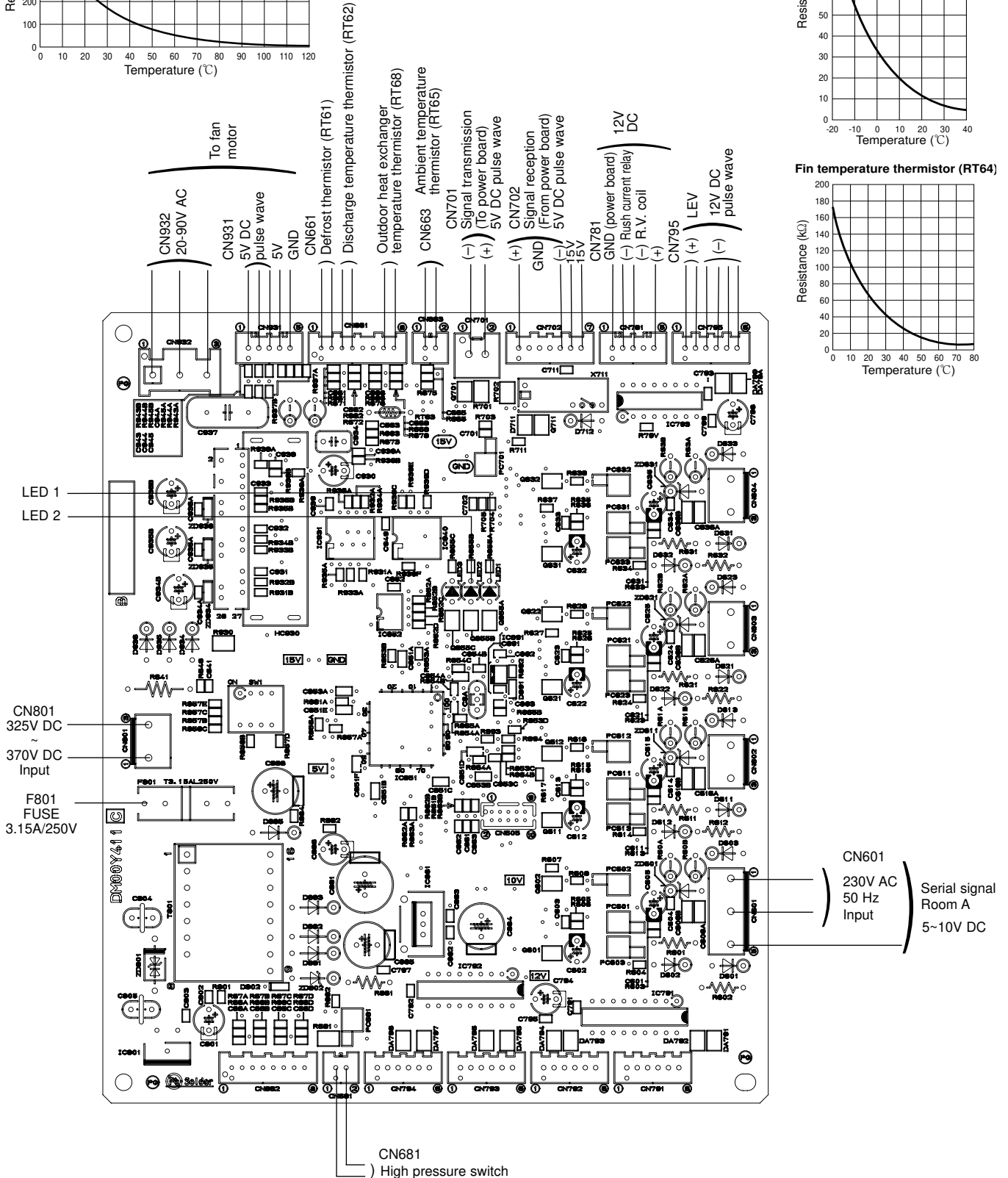
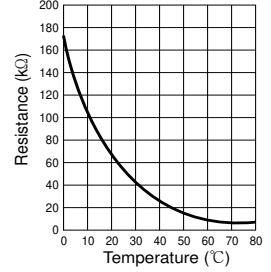

**11-6-5. Noise filter P.C. board  
SUZ-KA60VA2.TH**

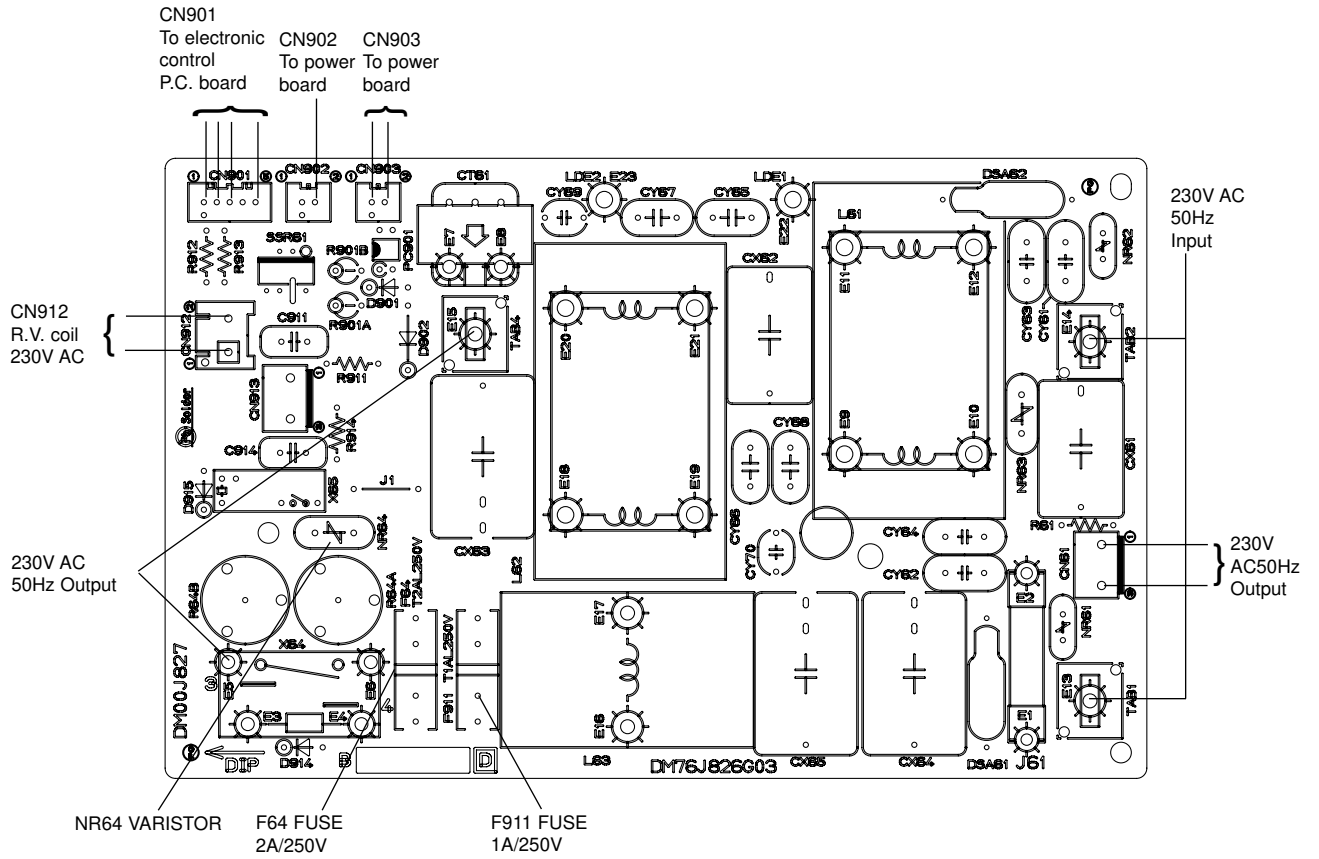

# 11-6-6. Outdoor power board SUZ-KA60VA2.TH

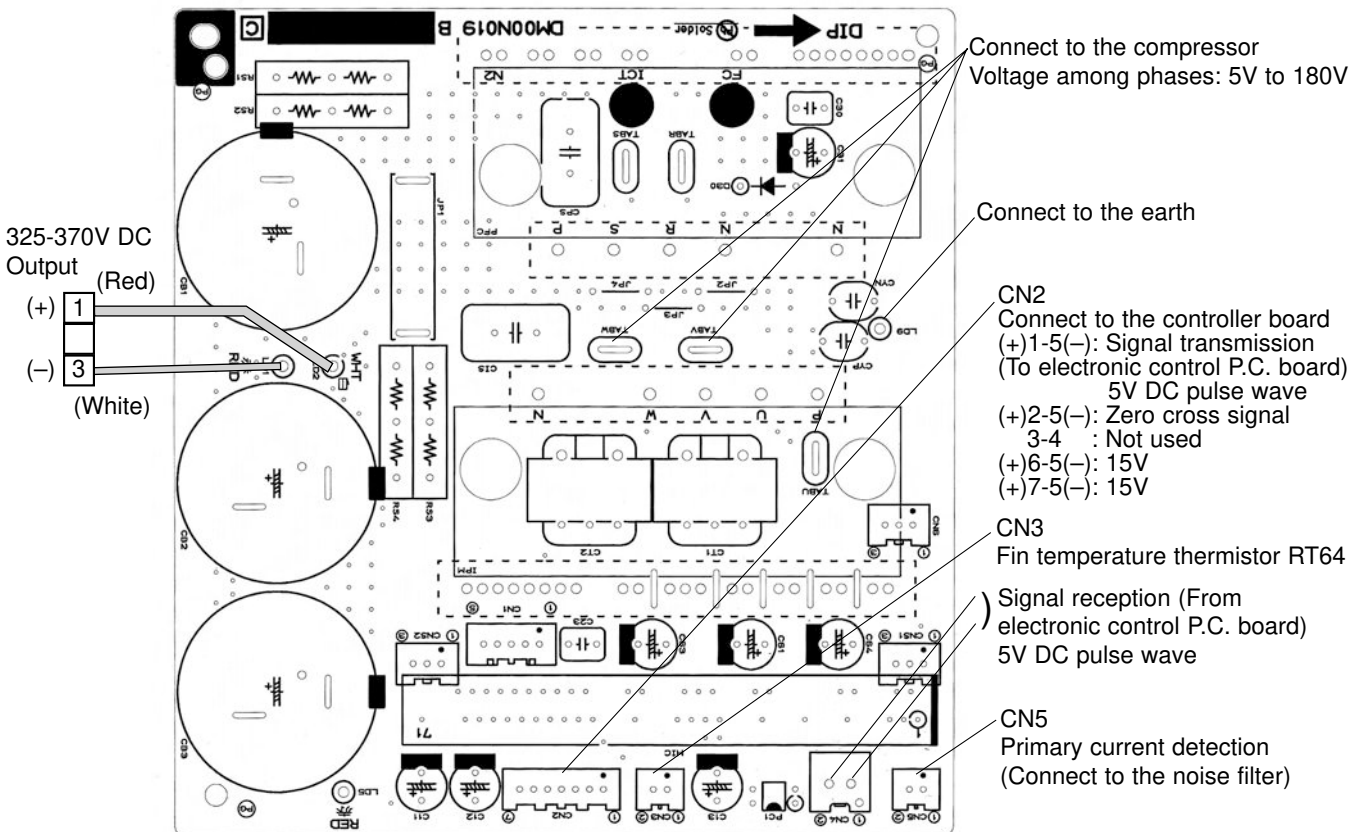
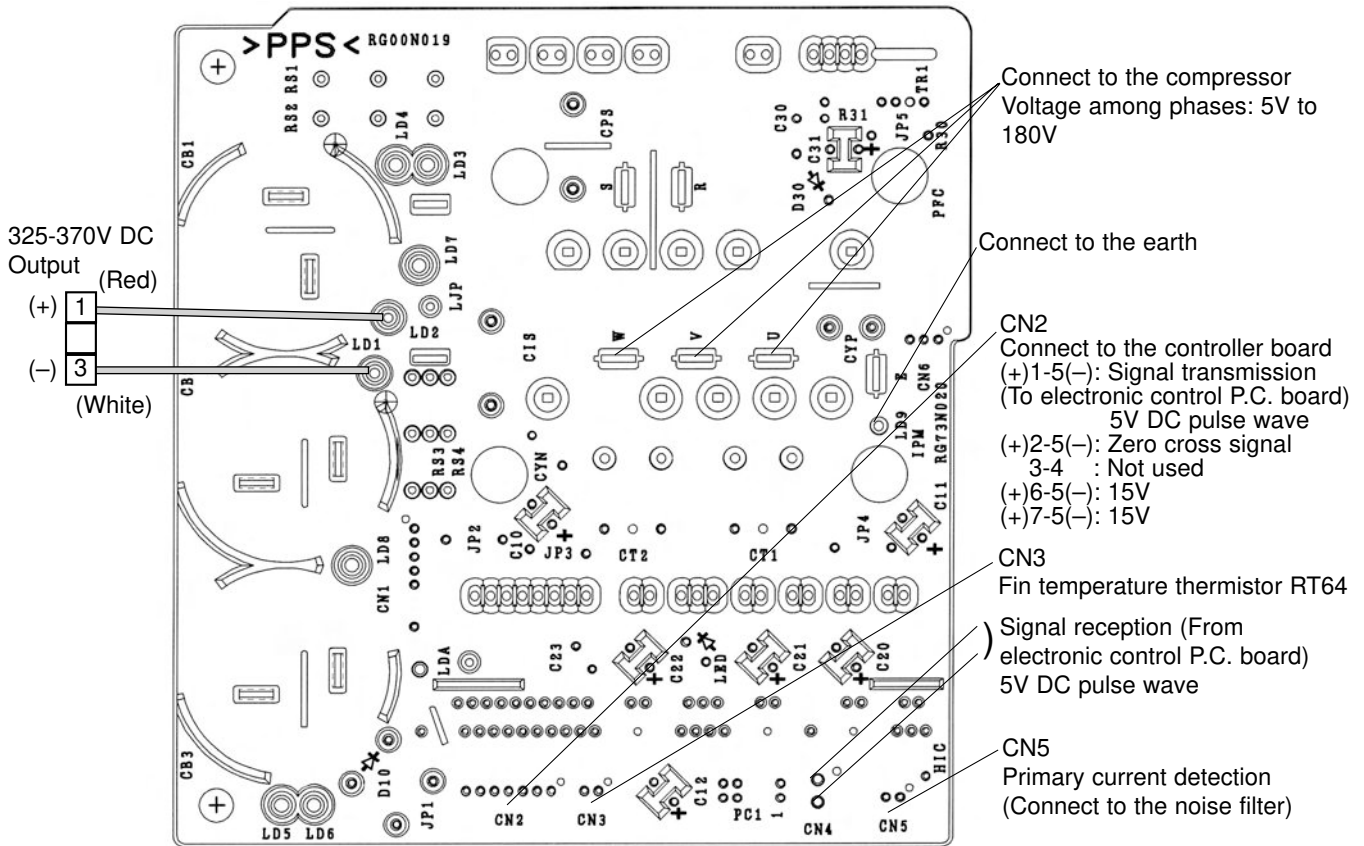

<"Terminal with locking mechanism" Detaching points>

The terminal which has the locking mechanism can be detached as shown below. There are two types ( Refer to (1) and (2)) of the terminal with locking mechanism. The terminal without locking mechanism can be detached by pulling it out. Check the shape of the terminal before detaching.

(1) Slide the sleeve and check if there is a locking lever or not.

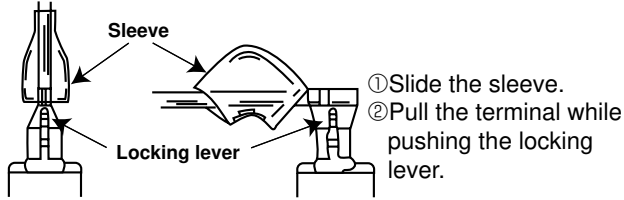

(2) The terminal with this connector has the locking mechanism.

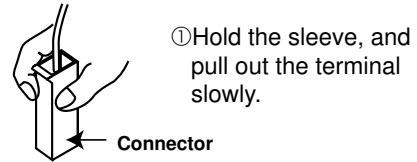

SUZ-KA25VA2.TH  
OUTDOOR UNIT

SUZ-KA35VA2.TH

NOTE: Turn OFF power supply before disassembling.

| OPERATING PROCEDURE   | PHOTOS   |
|---|--|
| <p><b>1. Removing the cabinet</b></p> <ol style="list-style-type: none"> <li>(1) Remove the screw fixing the service panel.</li> <li>(2) Pull down the service panel and remove it.</li> <li>(3) Disconnect the power supply and indoor/outdoor connecting wire.</li> <li>(4) Remove the screws fixing the top panel.</li> <li>(5) Remove the top panel.</li> <li>(6) Remove the screws fixing the cabinet.</li> <li>(7) Remove the cabinet.</li> <li>(8) Remove the screws fixing the back panel.</li> <li>(9) Remove the back panel.</li> </ol> | <p><b>Photo 1</b></p> <p>Screws of the top panel</p> <p>Screws of the top panel</p> <p>Back panel</p> <p>Screws of the cabinet</p> <p>Service panel</p> <p><b>Photo 2</b></p> <p>Screw of the cabinet</p> <p>Screw of the service panel</p> <p>Direction to remove</p> <p>Screws of the cabinet</p> <p>Hooks</p> |

## OPERATING PROCEDURE

### 2. Removing the inverter assembly, inverter P.C. board

- (1) Remove the cabinet and panels. (Refer to 1.)
- (2) Disconnect the lead wire to the reactor and the following connectors:  
<Inverter P.C. board>  
CN721 (R.V. coil)  
CN932 (Fan motor)  
CN641 (Defrost thermistor and discharge temperature thermistor)  
CN643 (Ambient temperature thermistor)  
CN644 (Outdoor heat exchanger temperature thermistor)  
CN724 (LEV)
- (3) Remove the compressor connector (CN61).
- (4) Remove the screws fixing the relay panel. (Photo 3)
- (5) Remove the inverter assembly. (Photo 4)
- (6) Remove the screw of the earth wire and screw of the T.B.support. (Photo 4)
- (7) Remove the relay panel from the inverter assembly.
- (8) Remove the inverter P.C. board from the relay panel.

### 3. Removing R.V. coil

- (1) Remove the cabinet and panels. (Refer to 1.)
- (2) Disconnect the following connectors:  
<Inverter P.C. board>  
CN721 (R.V. coil)
- (3) Remove the R.V. coil. (Photo 5)

### 4. Removing the discharge temperature thermistor, defrost thermistor, outdoor heat exchanger temperature thermistor and ambient temperature thermistor

- (1) Remove the cabinet and panels. (Refer to 1.)
- (2) Disconnect the lead wire to the reactor and the following connectors:  
<Inverter P.C. board>  
CN641 (Defrost thermistor and discharge temperature thermistor)  
CN643 (Ambient temperature thermistor)  
CN644 (Outdoor heat exchanger temperature thermistor)
- (3) Pull out the discharge temperature thermistor from its holder. (Photo 5)
- (4) Pull out the defrost thermistor from its holder. (Photo 6)
- (5) Pull out the outdoor heat exchanger temperature thermistor from its holder. (Photo 6)
- (6) Pull out the ambient temperature thermistor from its holder.

## PHOTOS

Photo 3

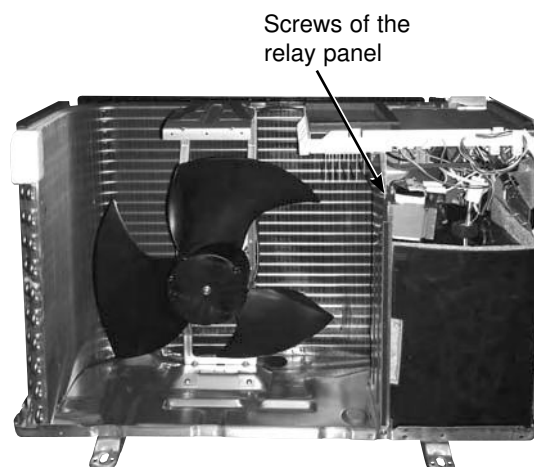

Photo 4 (Inverter assembly)

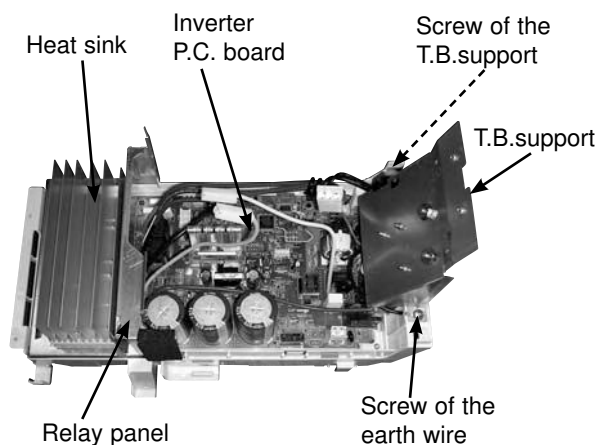

Photo 5



## OPERATING PROCEDURE

### 5. Removing outdoor fan motor

- (1) Remove the cabinet and panels. (Refer to 1.)
- (2) Disconnect the following connectors:  
<Inverter P.C. board>  
CN932 (Fan motor)
- (3) Remove the propeller nut. (Photo 7)
- (4) Remove the propeller. (Photo 7)
- (5) Remove the screws fixing the fan motor. (Photo 7)
- (6) Remove the fan motor.

### 6. Removing the compressor and 4-way valve

- (1) Remove the cabinet and panels. (Refer to 1.)
- (2) Remove the inverter assembly. (Refer to 2.)
- (3) Recover gas from the refrigerant circuit.  
**NOTE:** Recover gas from the pipes until the pressure gauge shows 0 kg/cm<sup>2</sup> (0 MPa).
- (4) Detach the welded part of the suction and the discharge pipe connected with compressor.
- (5) Remove the nuts of compressor legs.
- (6) Remove the compressor.
- (7) Detach the welded part of pipes connected with 4-way valve. (Photo 8)

## PHOTOS

Photo 6

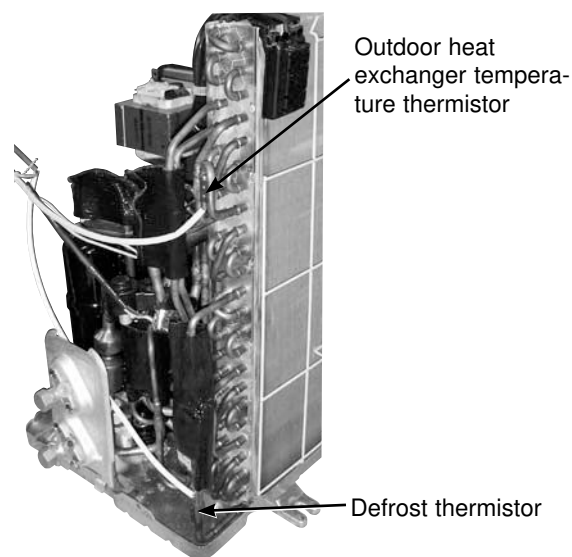

Photo 7

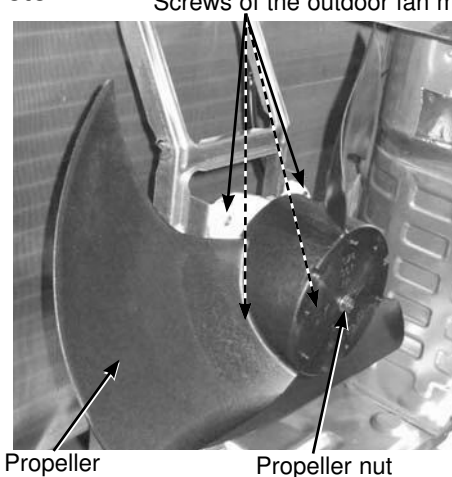
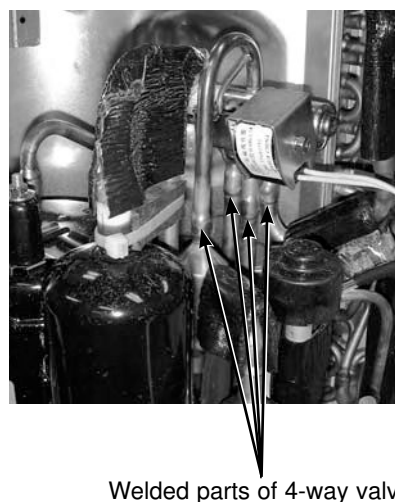
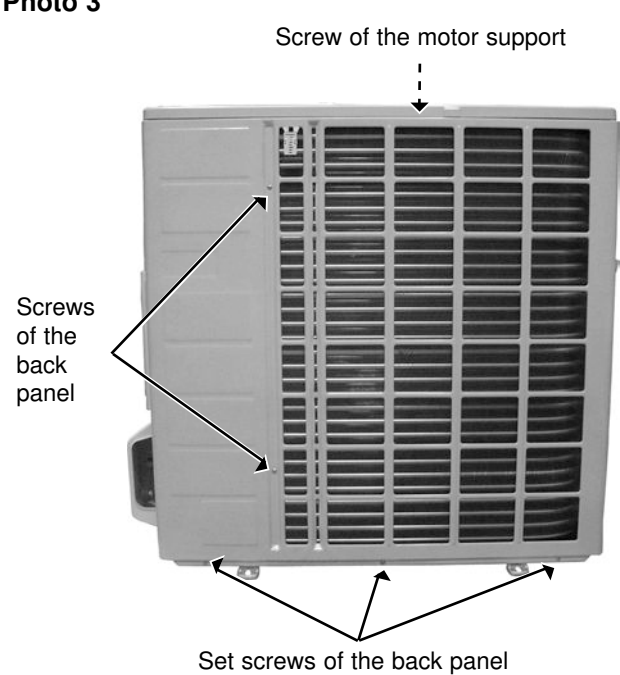
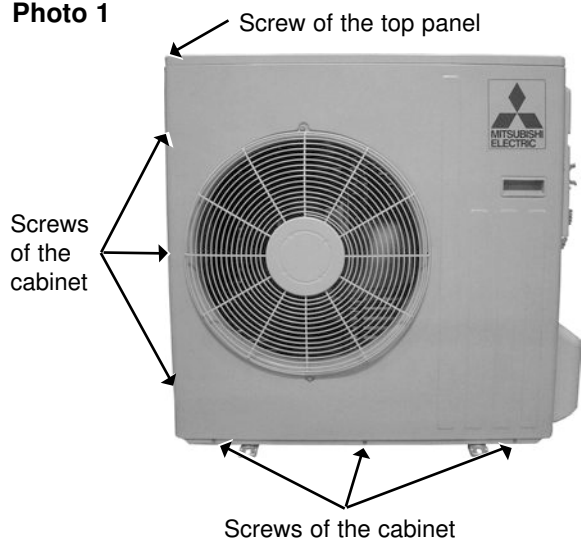
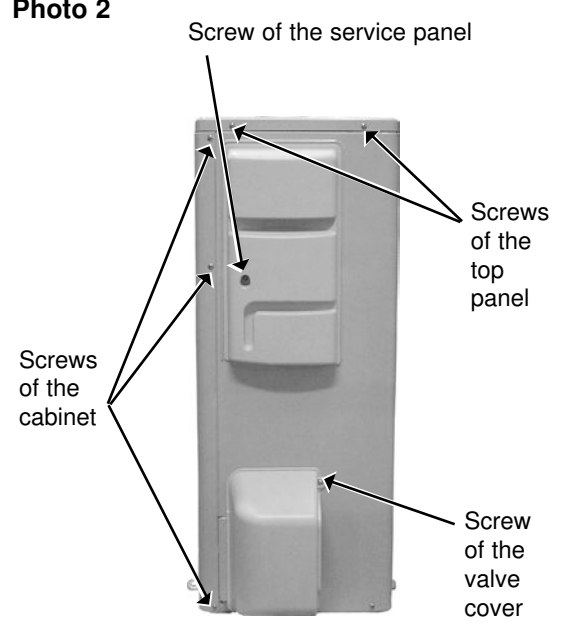

Photo 8



**NOTE:** Turn OFF power supply before disassembling.

| OPERATING PROCEDURE  | PHOTOS  |
|--|---|
| <p><b>1. Removing the cabinet</b></p> <ol style="list-style-type: none"> <li>(1) Remove the screws of the service panel.</li> <li>(2) Remove the screws of the top panel.</li> <li>(3) Remove the screw of the valve cover.</li> <li>(4) Remove the service panel.</li> <li>(5) Remove the top panel.</li> <li>(6) Remove the valve cover.</li> <li>(7) Remove the screws of the cabinet.</li> <li>(8) Remove the cabinet.</li> <li>(9) Remove the screws of the back panel.</li> <li>(10) Remove the back panel.</li> </ol><br><p><b>Photo 3</b></p>  | <p><b>Photo 1</b></p> <br><p><b>Photo 2</b></p>  |

## OPERATING PROCEDURE

### 2. Removing the inverter assembly, inverter P.C. board and power board (for SUZ-KA50VA2.TH)

- (1) Remove the top panel, cabinet, service panel and back panel. (Refer to 1.)
- (2) Disconnect the lead wire to the reactor and the following connectors;
  - <Inverter P.C. board>
  - CN721 (R.V.coil)
  - CN932 (Fan motor)
  - CN641 (Defrost thermistor and discharge temperature thermistor)
  - CN643 (Ambient temperature thermistor)
  - CN644 (Outdoor heat exchanger temperature thermistor)
  - CN724 (LEV)
- (3) Remove the compressor connector (CN61).
- (4) Remove the screws fixing the relay panel. (Photo 5)
- (5) Remove the inverter assembly. (Photo 6)
- (6) Remove the screw of the earth wire and screw of the T.B.support. (Photo 6)
- (7) Remove the screw of the PB fixture.
- (8) Remove the relay panel from the PB support.
- (9) Remove the inverter P.C. board from the inverter assembly.

### (for SUZ-KA60VA2.TH)

- (1) Remove the top panel, cabinet, service panel and back panel. (Refer to 1.)
- (2) Disconnect the following connectors;
  - <Electronic control P.C. board>
  - CN931 and CN932 (Fan motor)
  - CN795 (LEV)
  - CN661 (Discharge temperature thermistor, defrost thermistor and outdoor heat exchanger temperature thermistor)
  - <Noise filter P.C. board>
  - CN912 (4-way valve)
- (3) Remove the compressor connector.
- (4) Remove the screws fixing the relay panel.
- (5) Remove the inverter assembly.
- (6) Disconnect all connectors and lead wires on the electronic control P.C. board.
- (7) Remove the electronic control P.C. board from the inverter assembly.
- (8) Remove the screws fixing the power board assembly.
- (9) Disconnect all connectors and lead wires on the power board.
- (10) Remove the power board from the inverter assembly.
- (11) Disconnect all connectors and lead wires on the noise filter P.C. board.
- (12) Remove the noise filter P.C. board from the inverter assembly.

### 3. Removing R.V. coil

- (1) Remove the top panel, cabinet and service panel. (Refer to 1)
- (2) Remove the back panel. (Refer to 1.)
- (3) Disconnect the following connectors;
  - for SUZ-KA50VA2.TH**
  - <inverter P.C. board>
  - CN721 (R.V. coil)
  - for SUZ-KA60VA2.TH**
  - <Noise filter P.C. board>
  - CN912 (R.V. coil)
- (4) Remove the R.V. coil. (Photo 11)

## PHOTOS

Photo 4

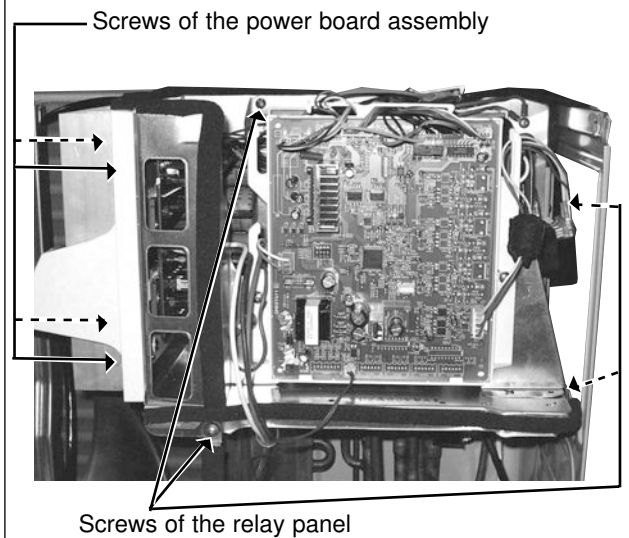

Photo 5 (SUZ-KA50VA2.TH)

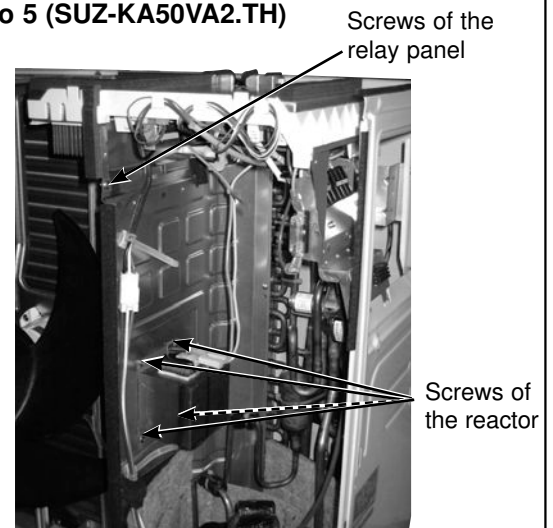
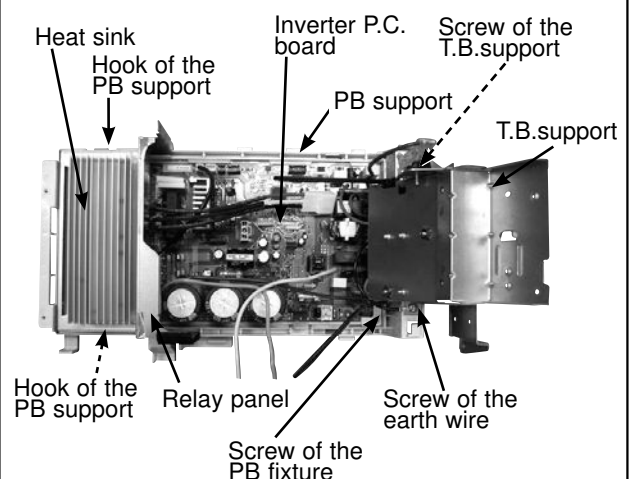

Photo 6 (SUZ-KA50VA2.TH)



## OPERATING PROCEDURE

### 4. Removing the defrost thermistor, discharge temperature thermistor, outdoor heat exchanger temperature thermistor and ambient temperature thermistor

- (1) Remove the top panel, cabinet and service panel.  
(Refer to 1.)
- (2) Remove the back panel. (Refer to 1.)
- (3) Remove the inverter assembly. (Refer to 2.)
- (4) Pull out the defrost thermistor from its holder. (Photo 8)
- (5) Pull out the discharge temperature thermistor from its holder. (Photo 7)
- (6) Pull out the outdoor heat exchanger temperature thermistor from its holder. (Photo 8)
- (7) Pull out the ambient temperature thermistor from its holder. (Photo 8)

## PHOTOS

Photo 7

Discharge temperature thermistor

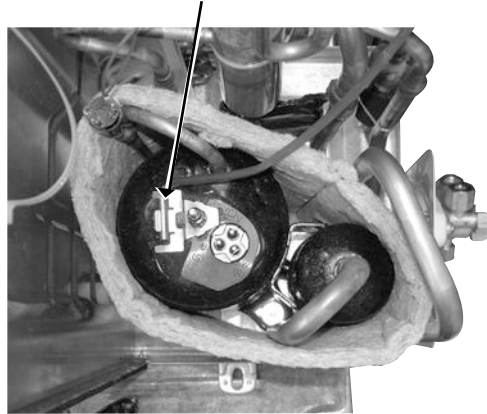
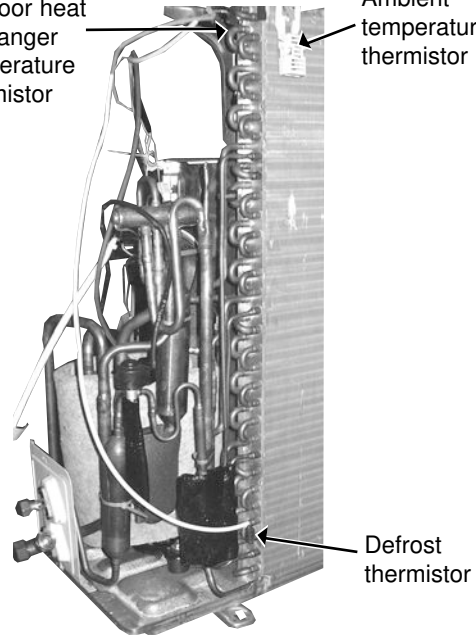

Photo 8

Outdoor heat exchanger temperature thermistor

Ambient temperature thermistor



### 5. Removing outdoor fan motor

- (1) Remove the top panel, cabinet and service panel.  
(Refer to 1.)
- (2) Remove the back panel. (Refer to 1.)
- (3) Disconnect the following connectors;  
**for SUZ-KA50VA2.TH**  
<Inverter P.C. board>  
CN931 and CN932 (Fan motor)  
  
**for SUZ-KA60VA2.TH**  
<Electric control P.C. board>  
CN931 and CN932 (Fan motor)
- (4) Remove the propeller.
- (5) Remove the screws fixing the fan motor.
- (6) Remove the fan motor

Photo 9

Screws of the outdoor fan motor

Propeller

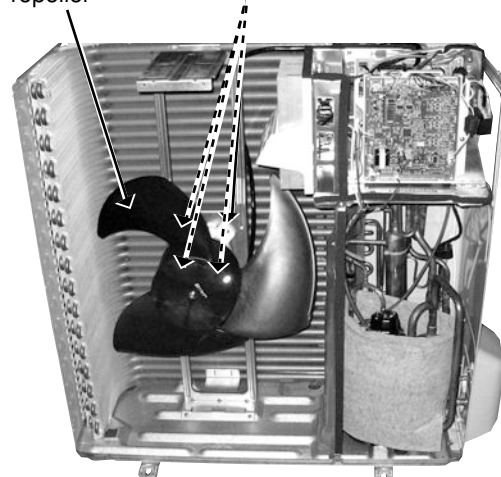

## OPERATING PROCEDURE

### 6. Removing the compressor and 4-way valve

(1) Remove the top panel, cabinet and service panel.  
(Refer to 1.)

(2) Remove the back panel. (Refer to 1.)

(3) Remove the inverter assembly. (Refer to 2.)

(4) Recover gas from the refrigerant circuit.

**NOTE:** Recover gas from the pipes until the pressure gauge shows 0 kg/cm<sup>2</sup> (0 MPa).

(5) Detach the welded part of the suction and the discharge pipe connected with compressor. (Photo 11)

(6) Remove the compressor nuts.

(7) Remove the compressor.

(8) Detach the welded part of 4-way valve and pipe. (Photo 10)

## PHOTOS

Photo 10

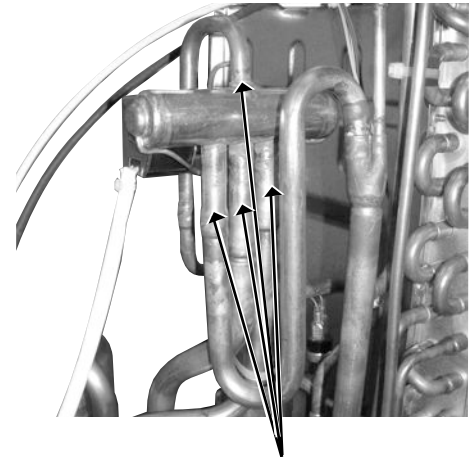

Welded parts of 4-way valve

Photo 11

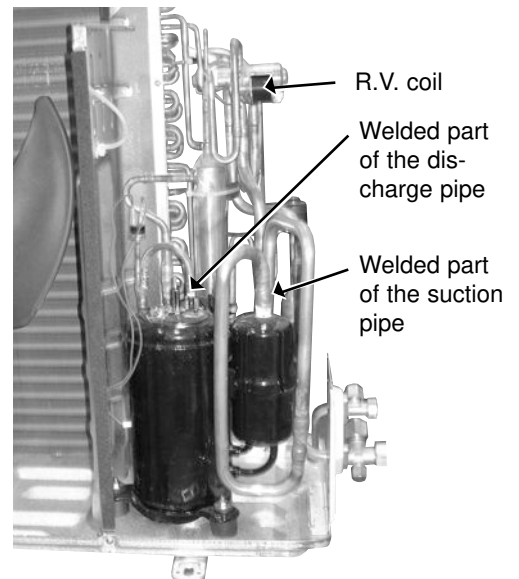

### 7. Removing the reactor

(1) Remove the top panel. (Refer to 1.)

(2) Disconnect the reactor lead wire.

(3) Remove the screws of the reactor, and remove the reactor.

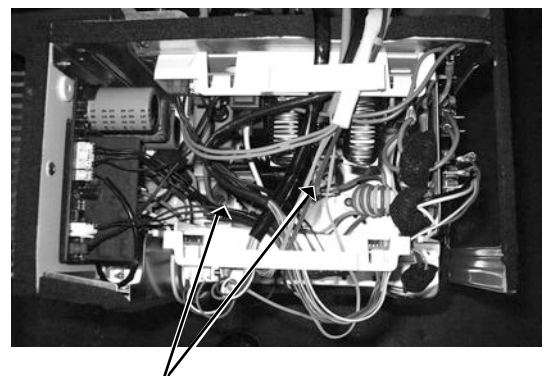

Photo 12



Screws of the reactor

# SUZ-KA71VA2.TH

**NOTE:** Turn OFF power supply before disassembling.

| OPERATING PROCEDURE  | PHOTOS  |
|--|---|
| <p><b>1. Removing the cabinet</b></p> <ol style="list-style-type: none"><li>(1) Remove the screws of the service panel.</li><li>(2) Remove the screws of the top panel.</li><li>(3) Remove the screw of the valve cover.</li><li>(4) Remove the service panel.</li><li>(5) Remove the top panel.</li><li>(6) Remove the valve cover.</li><li>(7) Disconnect the power supply and indoor/outdoor connecting wire.</li><li>(8) Remove the screws of the cabinet.</li><li>(9) Remove the cabinet.</li><li>(10) Remove the screws of the back panel.</li><li>(11) Remove the back panel.</li></ol> | <p><b>Photo 1</b></p>  <p>Screws of the top panel</p> <p>Screws of the cabinet</p> <p>Screws of the cabinet</p> <p><b>Photo 2</b></p>  <p>Screws of the top panel</p> <p>Screw of the back panel</p> <p>Screws of the cabinet</p> <p>Screws of the cabinet</p> <p>Screws of the service panel</p> <p>Screw of the valve cover</p> <p>Screws of the back panel</p> |

## OPERATING PROCEDURE

### 2. Removing the inverter assembly, inverter P.C. board

- (1) Remove the cabinet and panels. (Refer to 1.)
- (2) Disconnect the lead wire to the reactor and the following connectors:  
<Inverter P.C. board>  
CN602 (R.V. coil)  
CN931, CN932 (Fan motor)  
CN671 (Defrost thermistor, discharge temperature thermistor and outdoor heat exchanger temperature thermistor)  
CN672 (Ambient temperature thermistor)  
CN724 (LEV)
- (3) Remove the compressor connector.
- (4) Remove the screws fixing the relay panel.
- (5) Remove the relay panel.
- (6) Remove the earth wires and the lead wires of the inverter P.C. board.
- (7) Remove the screw of the PB support.
- (8) Remove the inverter P.C. board from the relay panel.

### 3. Removing R.V. coil

- (1) Remove the cabinet and panels. (Refer to 1.)
- (2) Disconnect the following connector:  
<Inverter P.C. board>  
CN602 (R.V. coil)
- (3) Remove the R.V. coil.

## PHOTOS

Photo 3

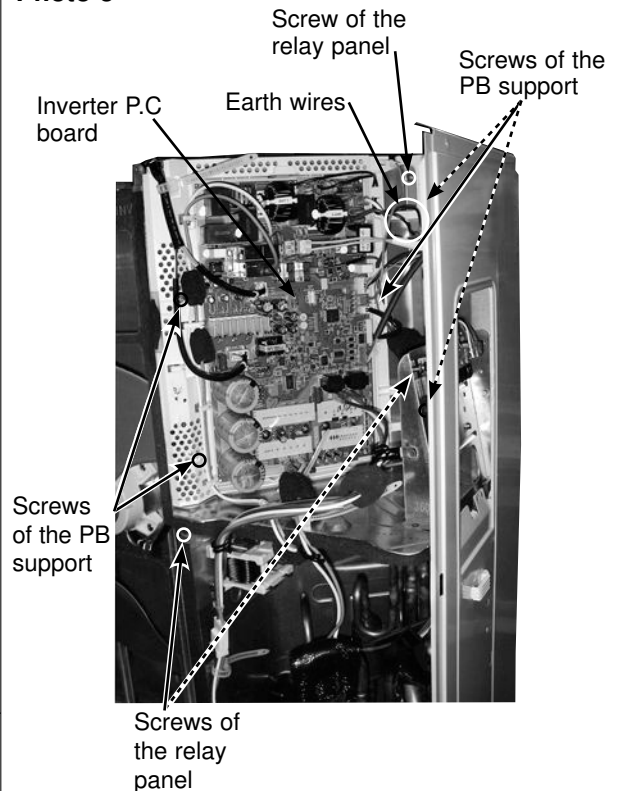
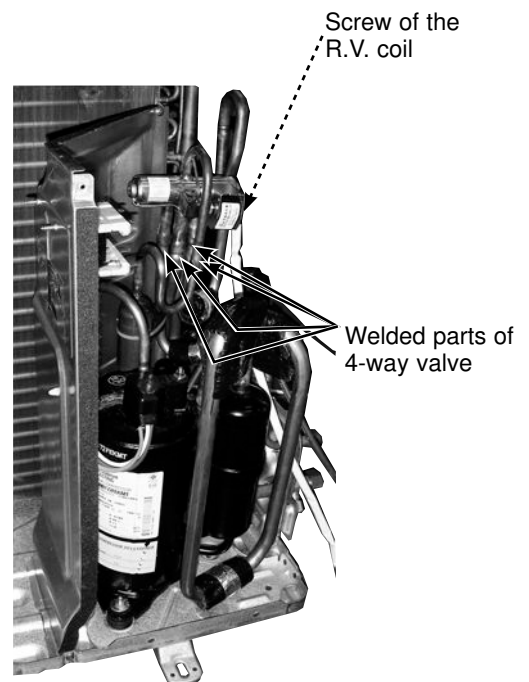

Photo 4



## OPERATING PROCEDURE

### 4. Removing the discharge temperature thermistor, defrost thermistor, outdoor heat exchanger temperature thermistor and ambient temperature thermistor

- (1) Remove the cabinet and panels. (Refer to 1.)
- (2) Disconnect the lead wire to the reactor and the following connectors:  
<Inverter P.C. board>  
CN671 (Defrost thermistor, discharge temperature thermistor and outdoor heat exchanger temperature thermistor)  
CN672 (Ambient temperature thermistor)
- (3) Pull out the discharge temperature thermistor from its holder. (Photo 7)
- (4) Pull out the defrost thermistor from its holder.
- (5) Pull out the outdoor heat exchanger temperature thermistor from its holder.
- (6) Pull out the ambient temperature thermistor from its holder.

### 5. Removing outdoor fan motor

- (1) Remove the top panel, cabinet and service panel. (Refer to 1.)
- (2) Disconnect the following connectors:  
<Inverter P.C. board>  
CN931 and CN932 (Fan motor)
- (3) Remove the propeller.
- (4) Remove the screws fixing the fan motor.
- (5) Remove the fan motor.

### 6. Removing the compressor and 4-way valve

- (1) Remove the top panel, cabinet and service panel. (Refer to 1.)
- (2) Remove the back panel. (Refer to 1.)
- (3) Remove the inverter assembly. (Refer to 2.)
- (4) Recover gas from the refrigerant circuit.  
**NOTE:** Recover gas from the pipes until the pressure gauge shows 0 kg/cm<sup>2</sup> (0 MPa).
- (5) Detach the welded part of the suction and the discharge pipe connected with compressor.
- (6) Remove the compressor nuts.
- (7) Remove the compressor.
- (8) Detach the welded part of 4-way valve and pipe. (Photo 4)

## PHOTOS

Photo 5

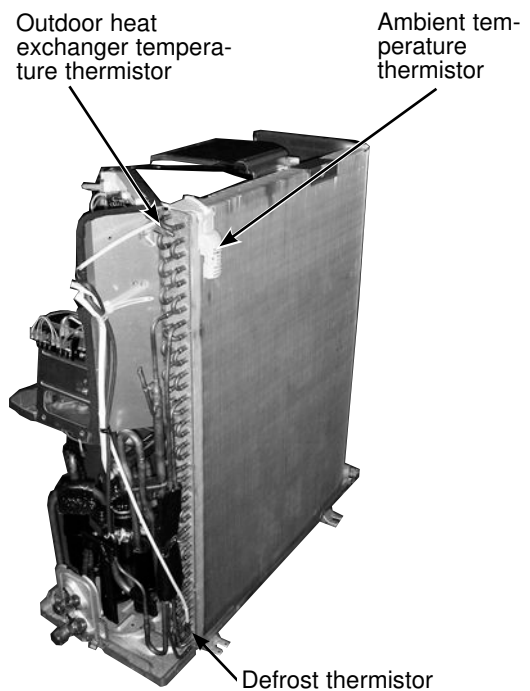

Photo 6

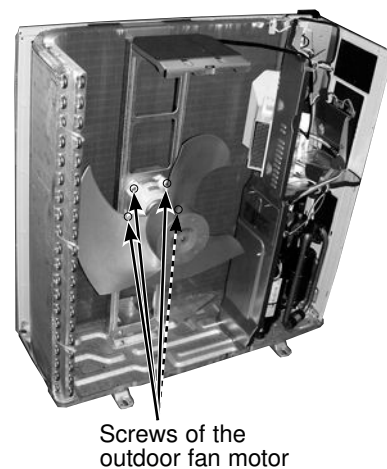

Photo 7

