

**Revision C:**

• Errors in TROUBLESHOOTING have been corrected.

Please void OBH489 REVISED EDITION-B.

# OUTDOOR UNIT SERVICE MANUAL



**No. OBH489**  
REVISED EDITION-C

## Models

- MUZ-FD25VA** - E1
- MUZ-FD25VAH** - E1, E2
- MUZ-FD35VA** - E1
- MUZ-FD35VAH** - E1
- MUZ-FD50VA** - E1

Indoor unit service manual  
MSZ-FD•VA Series (OBH488)

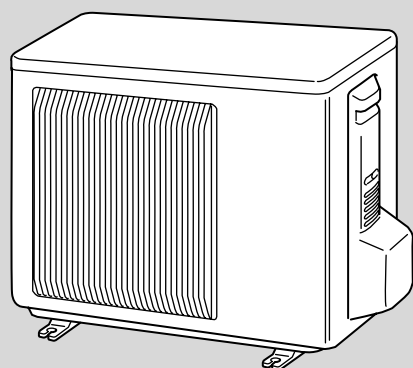

MUZ-FD25/35

## CONTENTS

1. TECHNICAL CHANGES .....	3
2. PART NAMES AND FUNCTIONS .....	4
3. SPECIFICATION .....	5
4. NOISE CRITERIA CURVES .....	8
5. OUTLINES AND DIMENSIONS .....	9
6. WIRING DIAGRAM .....	10
7. REFRIGERANT SYSTEM DIAGRAM .....	13
8. PERFORMANCE CURVES .....	15
9. ACTUATOR CONTROL .....	29
10. SERVICE FUNCTIONS .....	30
11. TROUBLESHOOTING .....	31
12. DISASSEMBLY INSTRUCTIONS .....	55

**PARTS CATALOG (OBB489)**

**NOTE:**

RoHS compliant products have <G> mark on the spec name plate.



## Use the specified refrigerant only

### Never use any refrigerant other than that specified.

Doing so may cause a burst, an explosion, or fire when the unit is being used, serviced, or disposed of.

Correct refrigerant is specified in the manuals and on the spec labels provided with our products.

We will not be held responsible for mechanical failure, system malfunction, unit breakdown or accidents caused by failure to follow the instructions.

### Revision A:

- MUZ-FD25VAH- [E2] has been added.
- Power outlet has been corrected.

### Revision B:

- MUZ-FD50VA- [E1] has been added.

### Revision J:

- Errors in TROUBLESHOOTING have been corrected.

# 1

## TECHNICAL CHANGES

**MUZ-FD25VA** -<sup>[E1]</sup>

**MUZ-FD25VAH** -<sup>[E1]</sup>

**MUZ-FD35VA** -<sup>[E1]</sup>

**MUZ-FD35VAH** -<sup>[E1]</sup>

**MUZ-FD50VA** -<sup>[E1]</sup>

1. New model

**MUZ-FD25VAH** -<sup>[E1]</sup> → **MUZ-FD25VAH** -<sup>[E2]</sup>

1. Power outlet <sup>[E1]</sup>: 12 A, <sup>[E2]</sup>: 10 A

## 2

# PART NAMES AND FUNCTIONS

MUZ-FD25VA MUZ-FD25VAH MUZ-FD35VA MUZ-FD35VAH

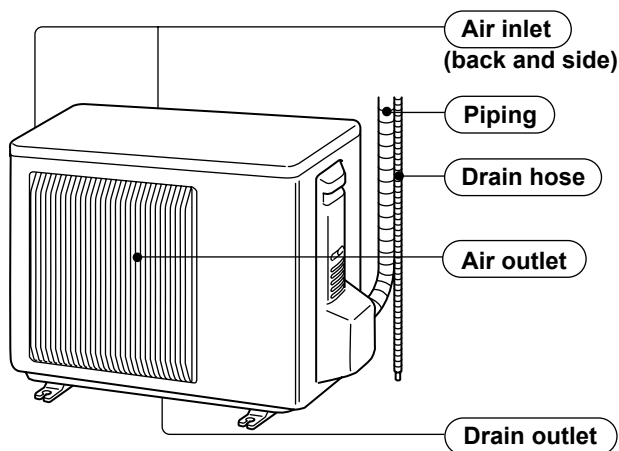

MUZ-FD50VA

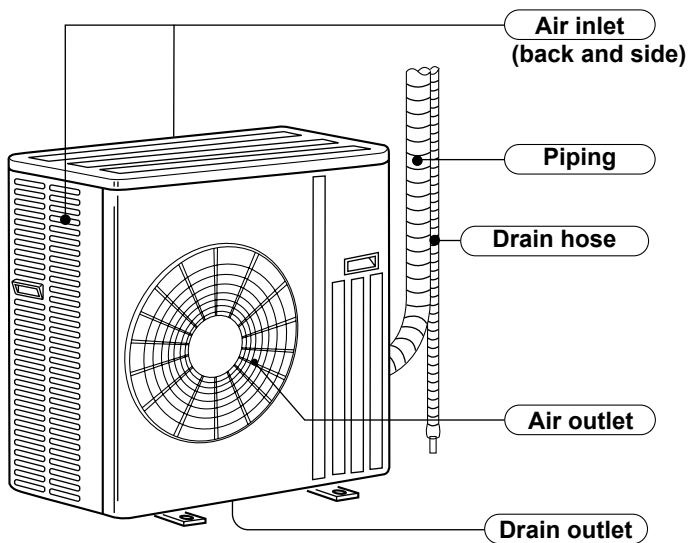

## ACCESSORIES

	MUZ-FD25/35VA	MUZ-FD50VA
① Drain socket	1	1
② Drain cap	-	2

## 3

## SPECIFICATION

Outdoor model				MUZ-FD25VA	MUZ-FD25VAH	MUZ-FD35VA	MUZ-FD35VAH
Power supply				Single phase, 230 V, 50 Hz			
Capacity	Cooling	kW	2.5 (1.1-3.5)		3.5 (1.1-4.0)		3.5 (0.8-4.0)
Rated frequency (Min.-Max.)	Heating		3.2 (1.5-5.5)		3.2 (1.5-6.3)		4.0 (1.5-6.3)
Breaker Capacity			A	10	E1: 12 E2: 10	10	12
Electrical data	Power input *1 (Total)	Cooling	W	485		850	835
		Heating		610		865	850
	Running current *1 (Total)	Cooling	A	2.4		3.9	3.8
		Heating		2.9		4.0	3.9
	Power factor *1 (Total)	Cooling	%	88		95	96
		Heating		91		94	95
Starting current *1 (Total)		A	2.9		4.0	3.9	
Coefficient of performance (COP) *1 (Total)		Cooling	5.15		4.12	4.19	
		Heating	5.25		4.62	4.71	
Compressor		Model		SNB130FGBH			
		Output		W			
				900			
		Current *1	Cooling	1.88		3.31	3.21
			Heating	2.30		3.33	3.23
		Refrigeration oil (Model)		L			
				0.45 (NEO22)			
Fan motor		Model		RC0J50-EA			
		Current *1	Cooling	0.27		0.32	
			Heating	0.30		0.35	
Dimensions W × H × D			mm	800 × 550 × 285			
Weight			kg	36			
Special remarks	Dehumidification		Cooling	ℓ/h		1.4	2.0
	Air flow *1	Cooling	High	m <sup>3</sup> /h		1,872	
			Low			1,086	
		Heating	High			2,016	
			Med.			1,776	
			Low	1,386			
	Sound level *1		Cooling	dB(A)		46	
			Heating			47	
						50	
	Fan speed	Cooling	High	rpm		810	
			Low			490	
		Heating	High			870	
Med.			770				
Low			610				
Fan speed regulator					3		
Refrigerant filling capacity (R410A)			kg	1.15			

**NOTE:** Test conditions are based on ISO 5151.  
Cooling: Indoor Dry-bulb temperature 27°C  
Outdoor Dry-bulb temperature 35°C  
Heating: Indoor Dry-bulb temperature 20°C  
Outdoor Dry-bulb temperature 7°C  
Refrigerant piping length (one way): 5 m  
\*1 Measured under rated operating frequency.

Wet-bulb temperature 19°C

Wet-bulb temperature 6°C



Outdoor model				MUZ-FD50VA	
Power supply				Single phase, 230 V, 50 Hz	
Capacity Rated frequency (Min.-Max.)	Cooling	kW	5.0 (1.5-5.8)		
	Heating		5.8 (1.5-7.8)		
Breaker Capacity		A	16		
Electrical data	Power input *1 (Total)	Cooling	W	1,500	
		Heating		1,550	
	Running current *1 (Total)	Cooling	A	6.7	
		Heating		6.9	
	Power factor *1 (Total)	Cooling	%	98	
		Heating		98	
Starting current *1 (Total)		A	6.9		
Coefficient of performance (COP) *1 (Total)		Cooling	3.33		
		Heating	3.74		
Compressor	Model		SNB172FDGH		
	Output		W	1,200	
	Current *1	Cooling	A	5.40	
		Heating		5.62	
Refrigeration oil (Model)		L	0.45 (NEO22)		
Fan motor	Model		RC0J60-AA		
	Current *1	Cooling	A	0.72	
Heating					
Dimensions W × H × D			mm	840 × 850 × 330	
Weight			kg	55	
Special remarks	Dehumidification		Cooling	ℓ/h	1.7
	Air flow *1	Cooling	High	m <sup>3</sup> /h	–
			Med.		2,940
			Low		1,680
		Heating	High		2,940
			Med.		2,940
			Low		2,100
	Sound level *1		Cooling	dB(A)	54
			Heating		56
	Fan speed	Cooling	High	rpm	–
			Med.		800
			Low		480
		Heating	High		800
			Med.		800
Low			580		
Fan speed regulator			2		
Refrigerant filling capacity (R410A)		kg	1.55		

**NOTE:** Test conditions are based on ISO 5151.  
 Cooling: Indoor Dry-bulb temperature 27°C  
           Outdoor Dry-bulb temperature 35°C  
 Heating: Indoor Dry-bulb temperature 20°C  
           Outdoor Dry-bulb temperature 7°C  
 Refrigerant piping length (one way): 5 m  
 \*1 Measured under rated operating frequency.

Wet-bulb temperature 19°C  
 Wet-bulb temperature 6°C



**Specifications and rated conditions of main electric parts**

Item	Model	MUZ-FD25VA	MUZ-FD25VAH	MUZ-FD35VA	MUZ-FD35VAH
	Current transformer	(CT)	20 A		
(CT761, CT781)		15 A			
Smoothing capacitor	(C61, C62, C63)	620 $\mu$ F 420 V			
Diode module	(DB61)	15 A 600 V			
	(DB65)	25 A 600 V			
Fuse	(F61)	T20AL250V			
	(F701, F801, F901)	T3.15AL250V			
Defrost heater	(H)	—	230 V 130 W	—	230 V 130 W
Intelligent power module	(IPM)	20 A 600 V			
Expansion valve coil	(LEV)	DC 12 V			
Reactor	(L61)	23.0 mH			
Current-detecting resistor	(R61, R62)	180 m $\Omega$ 5 W (2 elements)			
	(R825)	25 m $\Omega$ 5 W			
	(R937, R938, R939)	430 m $\Omega$ 2 W			
Current-limiting PTC thermistor	(PTC64, PTC65)	33 $\Omega$			
Terminal block	(TB1, TB2)	3 P			
Relay	(X63)	3 A 250 V			
	(X64)	20 A 250 V			
	(X66)	—	3 A 250 V	—	3 A 250 V
R.V.coil	(21S4)	AC 220 - 240 V			
Heater protector	(26H)	—	Open 45°C	—	Open 45°C
IGBT	(TR821)	30 A 600 V			

Item	Model	MUZ-FD50VA
	Current transformer	(CT1, CT2)
(CT61)		20 A
Smoothing capacitor	(CB1, CB2, CB3)	560 $\mu$ F 450 V
Fuse	(F64)	T2.0AL250V
	(F801)	T3.15AL250V
Expansion valve coil	(LEV)	DC 12 V
Intelligent power module	(IPM)	15 A 600 V
	(HC930)	3 A 600 V
High pressure switch	(HPS)	ACB-DB156
Reactor	(L)	600 $\mu$ H 20 A
Power factor correct module	(PFC)	20 A 600 V
Current-limiting PTC thermistor	(PTC64, PTC65)	33 $\Omega$
Current-detecting resistor	(R937A, R937B)	1.1 $\Omega$ 2 W
	(RS1, RS2, RS3, RS4)	40 m $\Omega$ 7 W (2 elements)
Solenoid coil relay	(SSR61)	0.5 A 600 V
Terminal block	(TB1, TB2)	3 P
Relay	(X64)	20 A 250 V
R.V. coil	(21S4)	AC 220 - 240 V

## MUZ-FD25VA MUZ-FD25VAH

FUNCTION	SPL(dB(A))	LINE
COOLING	46	
HEATING		

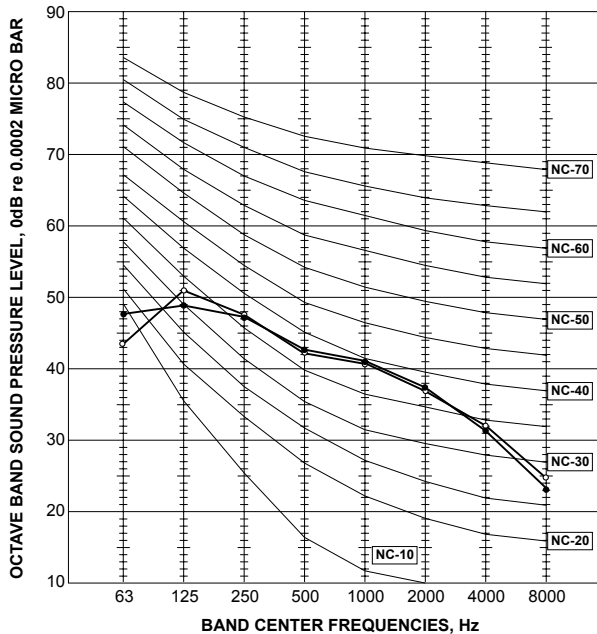

## MUZ-FD35VA MUZ-FD35VAH

FUNCTION	SPL(dB(A))	LINE
COOLING	47	
HEATING		50

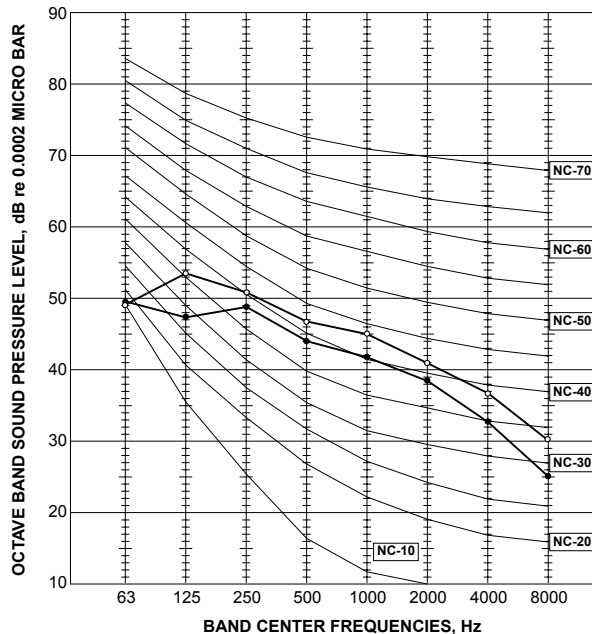

## MUZ-FD50VA

FUNCTION	SPL(dB(A))	LINE
COOLING	54	
HEATING		56

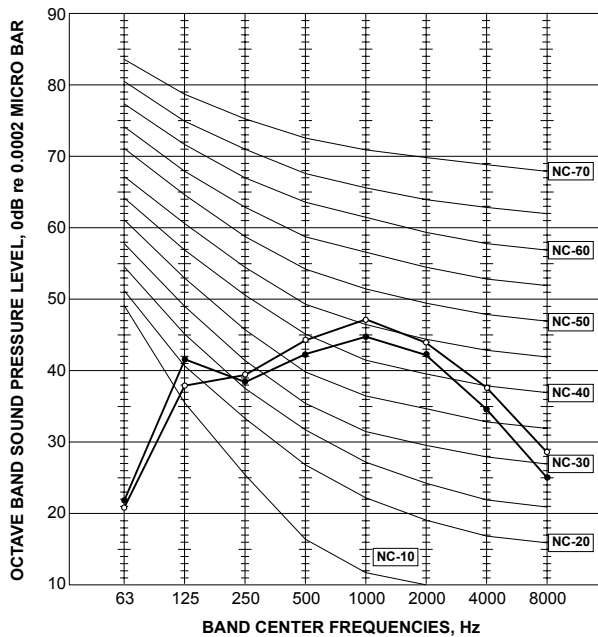

### Test conditions

Cooling : Dry-bulb temperature 35 °C

Heating : Dry-bulb temperature 7 °C Wet-bulb temperature 6 °C

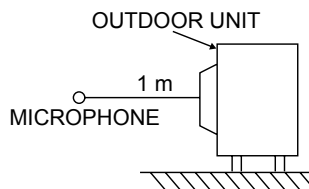

# 5

# OUTLINES AND DIMENSIONS

MUZ-FD25VA MUZ-FD25VAH MUZ-FD35VA MUZ-FD35VAH

Unit: mm

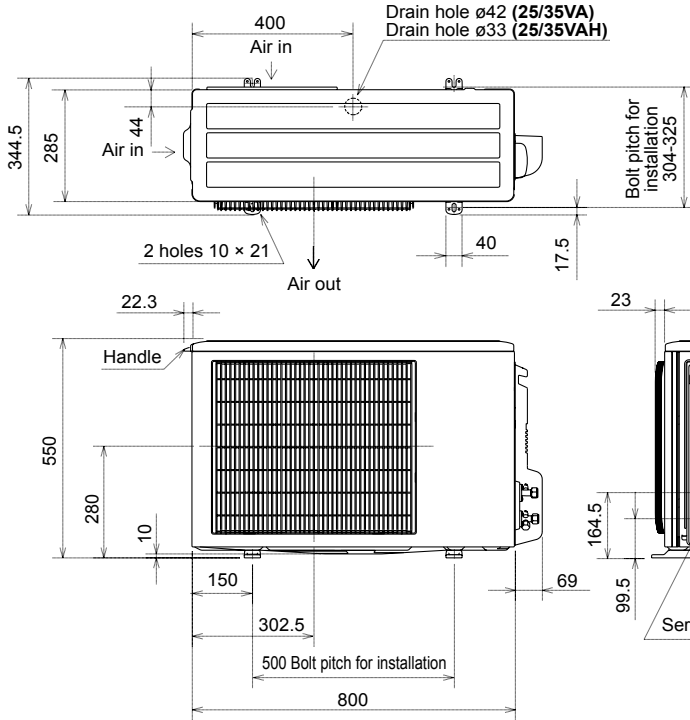

## REQUIRED SPACE

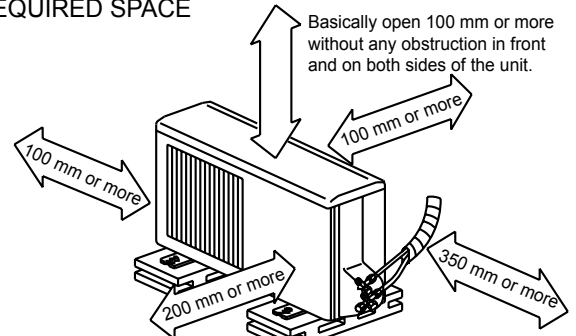

Open two sides of left, right, or rear side.

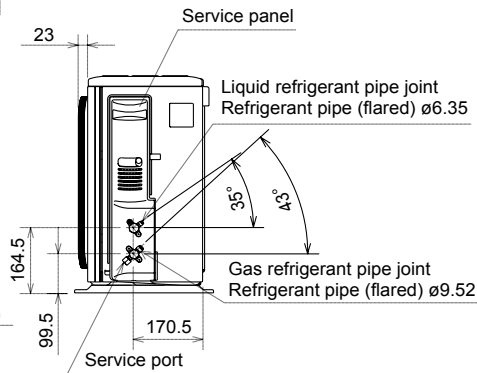

## MUZ-FD50VA

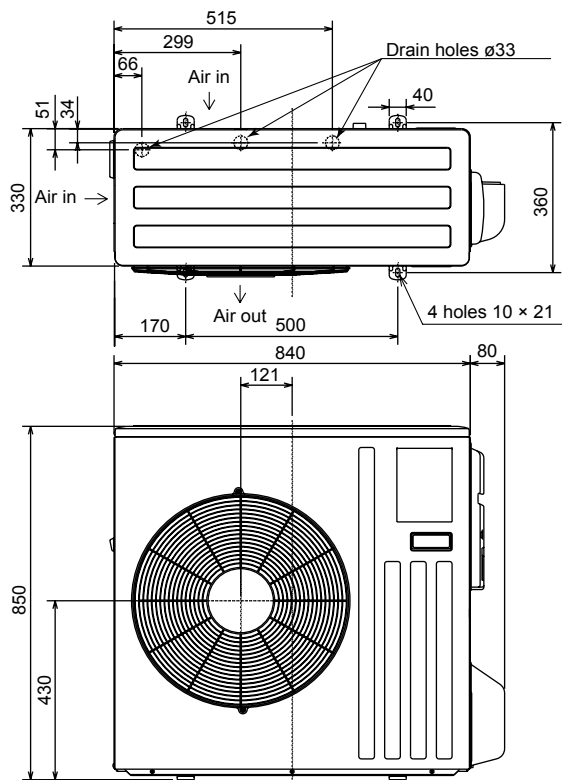

## REQUIRED SPACE

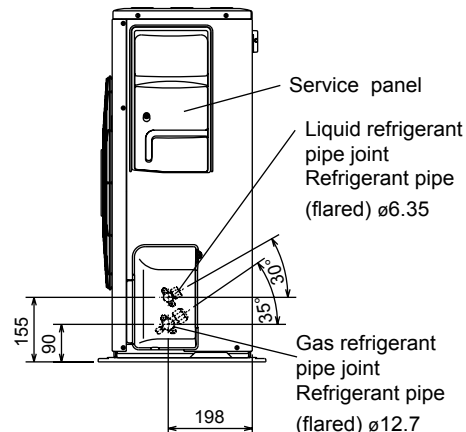
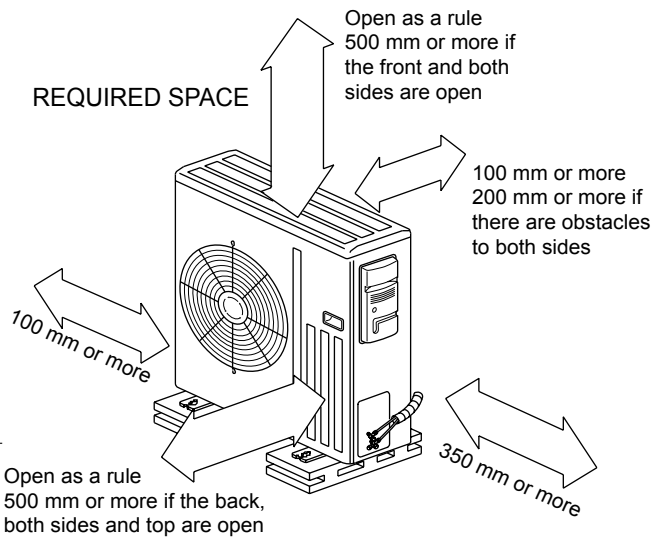

MUZ-FD25VA MUZ-FD35VA

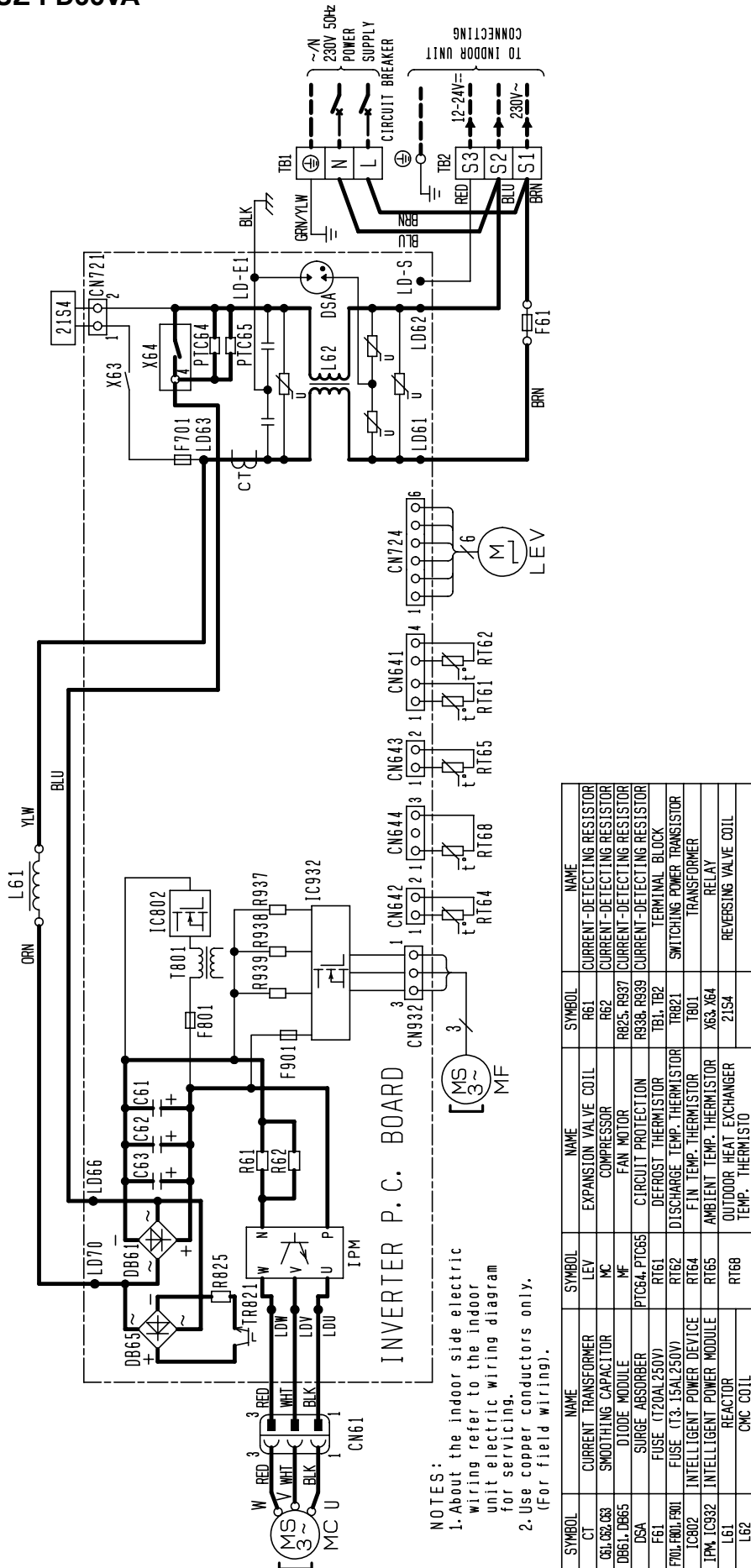

SYMBOL	NAME	SYMBOL	NAME	SYMBOL	NAME
CT	CURRENT TRANSFORMER	LEV	EXPANSION VALVE COIL	R61	CURRENT-DETECTING RESISTOR
C61, C62, C63	SMOOTHING CAPACITOR	MC	COMPRESSOR	R62	CURRENT-DETECTING RESISTOR
DB61, DB65	DIODE MODULE	MF	FAN MOTOR	R825, R937	CURRENT-DETECTING RESISTOR
DSA	SURGE ABSORBER	PTC64, PTC65	CIRCUIT PROTECTION	R938, R939	CURRENT-DETECTING RESISTOR
F61	FUSE (T20AL/250V)	RT61	DEFROST THERMISTOR	TB1, TB2	TERMINAL BLOCK
F701, F801, F901	FUSE (T3.15AL/250V)	RT62	DISCHARGE TEMP. THERMISTOR	TR821	SWITCHING POWER TRANSISTOR
IC802	INTELLIGENT POWER DEVICE	RT64	FIN TEMP. THERMISTOR	T801	TRANSFORMER
IPM, IC932	INTELLIGENT POWER MODULE	RT65	AMBIENT TEMP. THERMISTOR	X63, X64	RELAY
L61	REACTOR	RT68	OUTDOOR HEAT EXCHANGER TEMP. THERMISTOR	Z1S4	REVERSING VALVE COIL
L62	CMC COIL				

MUZ-FD25VAH  
MUZ-FD35VAH

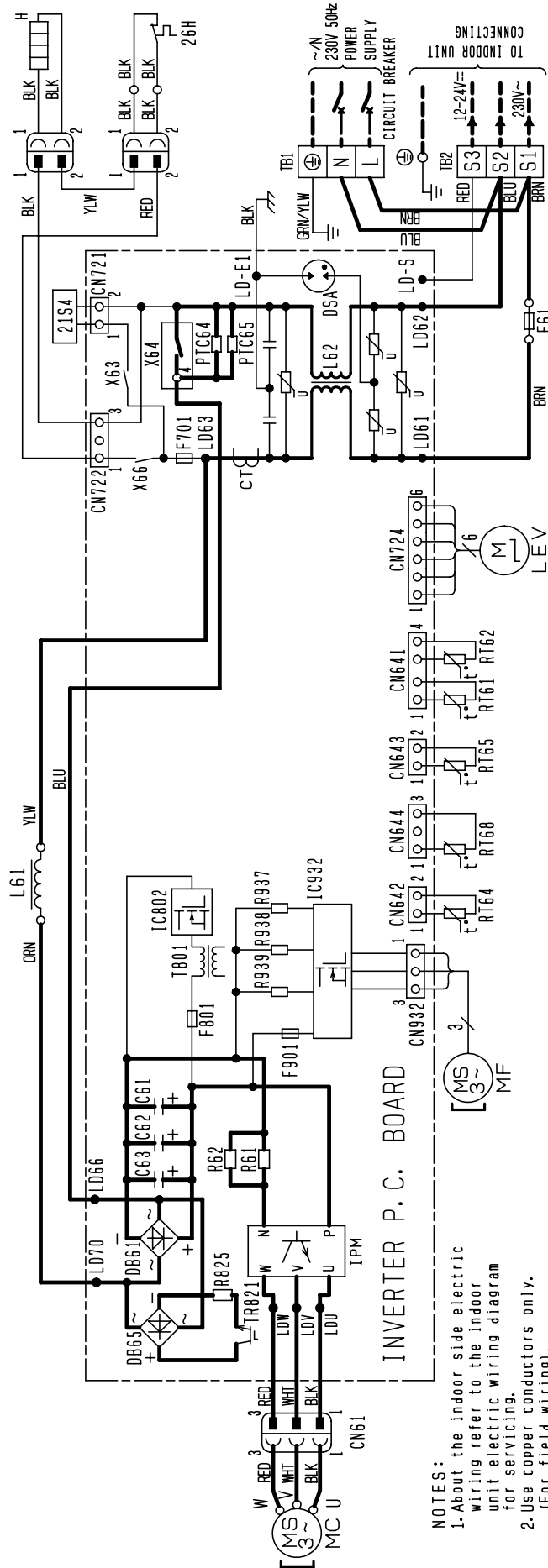

- NOTES:
- About the indoor side electric wiring refer to the indoor unit electric wiring diagram for servicing.
  - Use copper conductors only. (For field wiring).

SYMBOL	NAME	SYMBOL	NAME	SYMBOL	NAME
CT	CURRENT TRANSFORMER	LEV	EXPANSION VALVE COIL	R61, R62	CURRENT-DETECTING RESISTOR
C61, C62, C63	SMOOTHING CAPACITOR	MC	COMPRESSOR	R825, R937	CURRENT-DETECTING RESISTOR
DB61, DB65	DIODE MODULE	MF	FAN MOTOR	R938, R939	CURRENT-DETECTING RESISTOR
DSA	SURGE ABSORBER	PTC64, PTC65	CIRCUIT PROTECTION	TB1, TB2	TERMINAL BLOCK
F61	FUSE (T20AL250V)	RT61	DEFROST THERMISTOR	TR821	SWITCHING POWER TRANSISTOR TRANSFORMER
F701, F801, F901	FUSE (T3.15AL250V)	RT62	DISCHARGE TEMP. THERMISTOR	T801	TRANSFORMER
IC802	INTELLIGENT POWER DEVICE	RT64	FAN TEMP. THERMISTOR	X63, X64, X66	RELAY
IPM, IC932	INTELLIGENT POWER MODULE	RT65	AMBIENT TEMP. THERMISTOR	21S4	REVERSING VALVE COIL
L61	REACTOR	RT68	OUTDOOR HEAT EXCHANGER TEMP. THERMISTOR.	H	DEFROST HEATER
L62	CMC COIL			26H	HEATER PROTECTOR

# MUZ-FD50VA

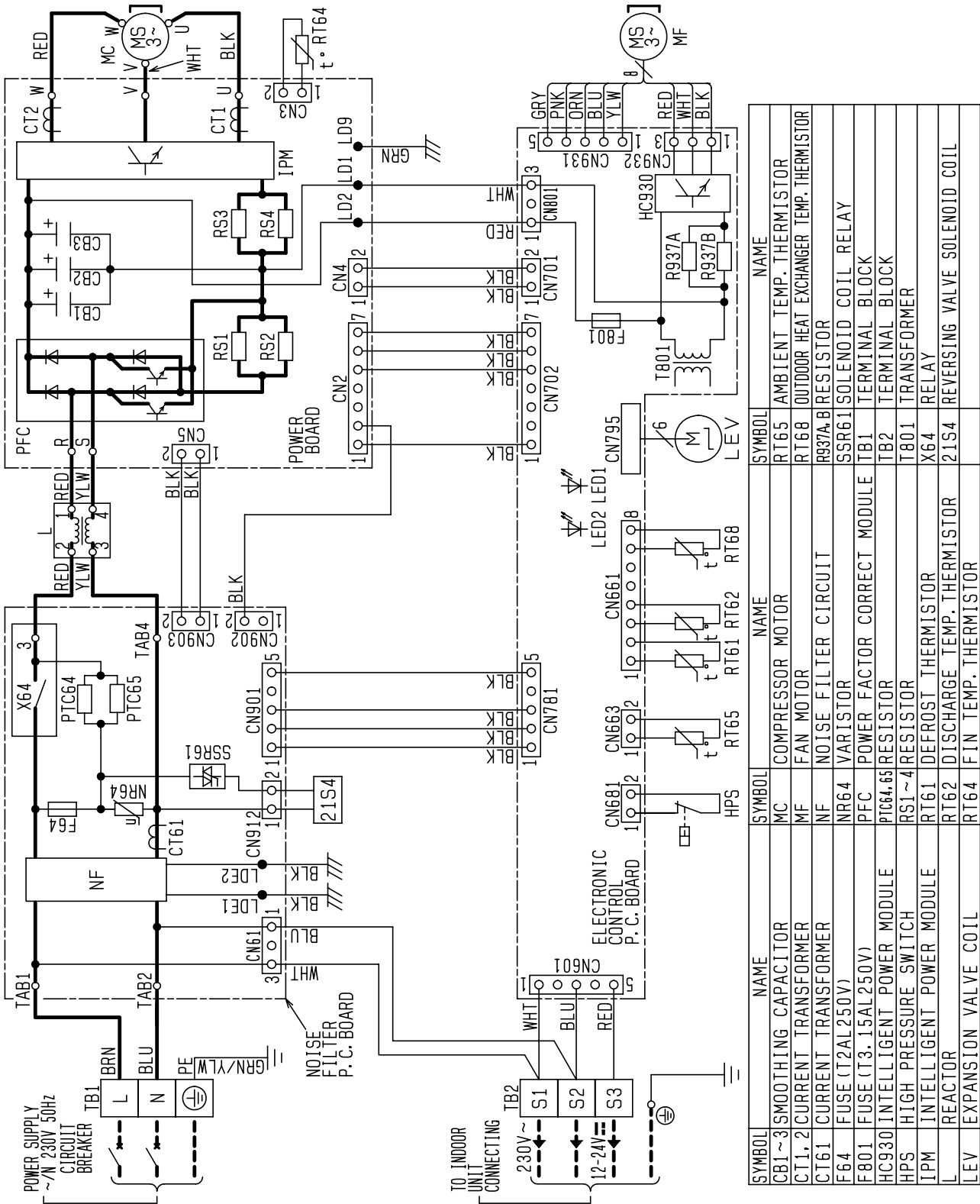

NOTES 1. About the indoor side electric wiring refer to the indoor unit electric wiring diagram for servicing.

2. Use copper conductors only (for field wiring). 3. Symbols indicate. □: terminal block

# 7

# REFRIGERANT SYSTEM DIAGRAM

MUZ-FD25VA MUZ-FD25VAH MUZ-FD35VA MUZ-FD35VAH

Unit: mm

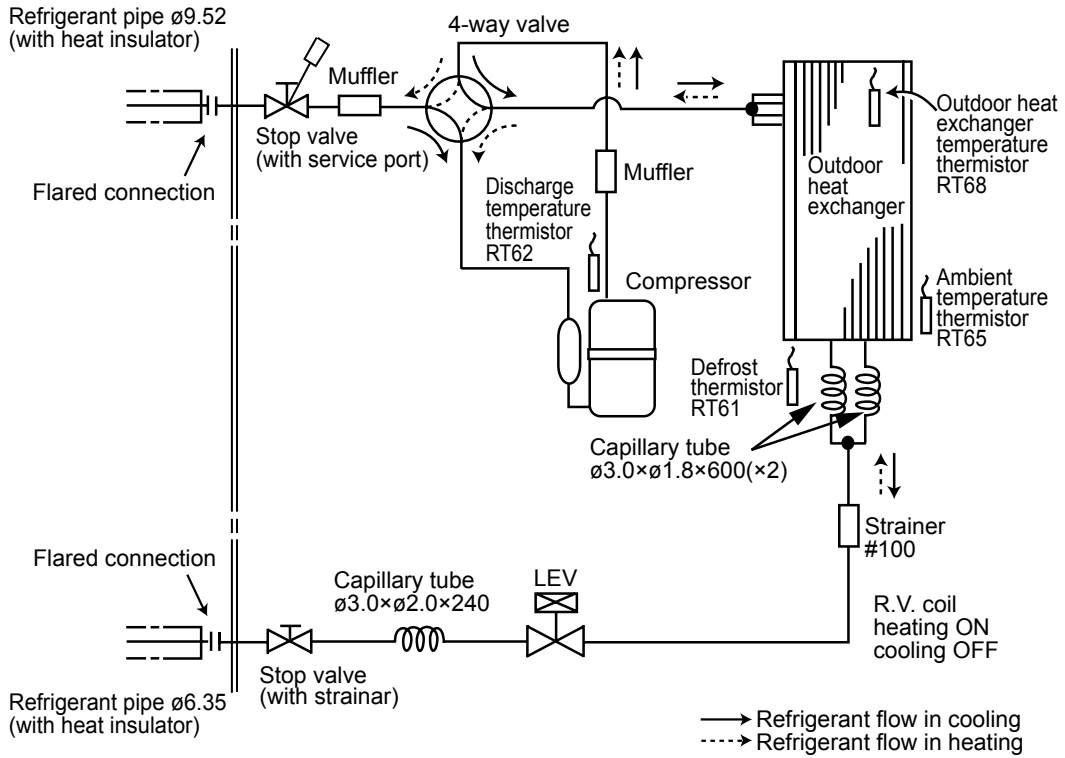

## MUZ-FD50VA

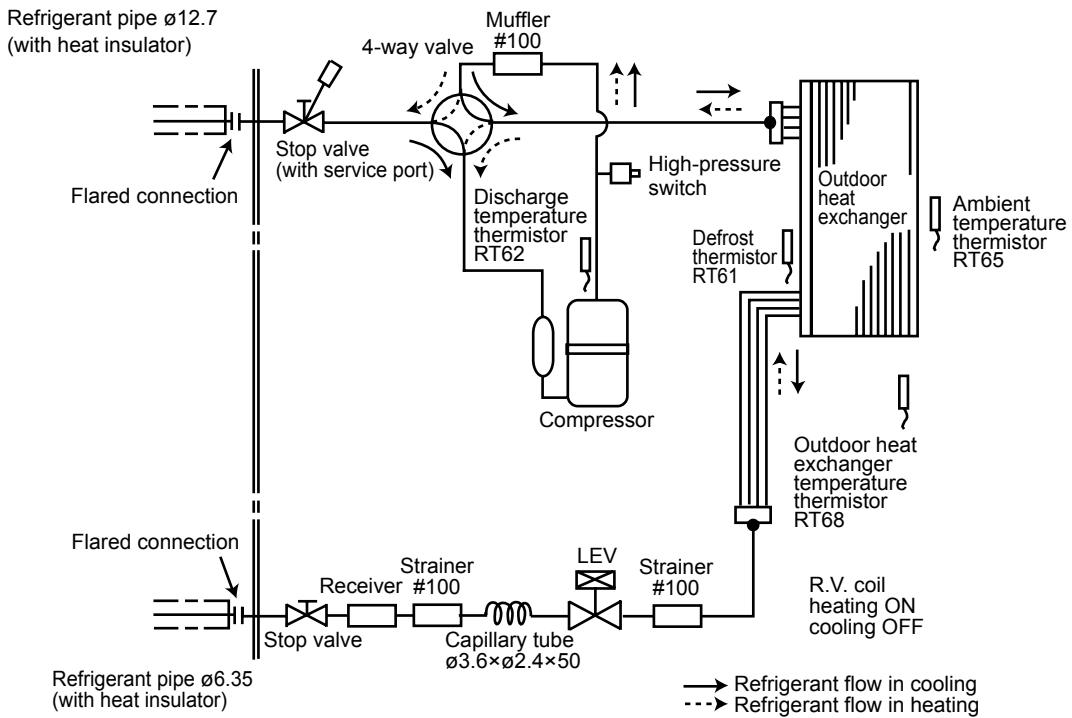



**MAX. REFRIGERANT PIPING LENGTH and MAX. HEIGHT DIFFERENCE**

	Refrigerant piping: m		Piping size O.D: mm	
	Max. Length A	Max. Height difference B	Gas	Liquid
<b>MUZ-FD25</b> <b>MUZ-FD35</b>	20	12	9.52	6.35
<b>MUZ-FD50</b>	30	15	12.7	

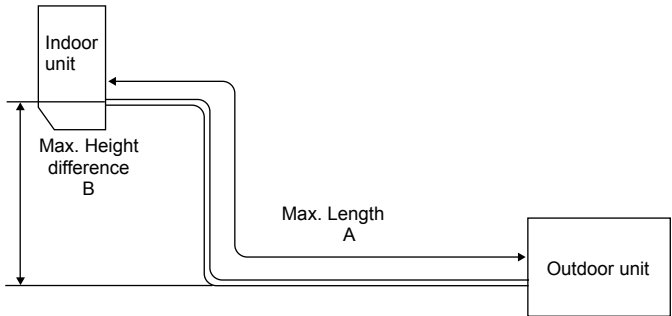

**ADDITIONAL REFRIGERANT CHARGE (R410A: g)**

Model	Outdoor unit precharged	Refrigerant piping length (one way)											
		5 m	6 m	7 m	8 m	9 m	10 m	11 m	12 m	13 m	14 m	15 m	20 m
<b>MUZ-FD25</b> <b>MUZ-FD35</b>	1,150	0	0	0	90	120	150	180	210	240	270	300	450

Calculation: X g = 30 g/m × (Refrigerant piping length (m) - 5)

Model	Outdoor unit precharged	Refrigerant piping length (one way)					
		7 m	10 m	15 m	20 m	25 m	30 m
<b>MUZ-FD50</b>	1,550	0	90	240	390	540	690

Calculation: X g = 30 g/m × (Refrigerant piping length (m) - 7)

**NOTE:** Refrigerant piping exceeding 7 m requires additional refrigerant charge according to the calculation.

**MUZ-FD25VA MUZ-FD25VAH MUZ-FD35VA MUZ-FD35VAH MUZ-FD50VA**

The standard specifications apply only to the operation of the air conditioner under normal conditions. Since operating conditions vary according to the areas where these units are installed, the following information has been provided to clarify the operating characteristics of the air conditioner under the conditions indicated by the performance curve.

**(1) GUARANTEED VOLTAGE**

198 ~ 264 V, 50 Hz

**(2) AIR FLOW**

Air flow should be set at MAX.

**(3) MAIN READINGS**

- |  |         |           |
|--|---------|-----------|
| (1) Indoor intake air wet-bulb temperature:  | °C [WB] | } Cooling |
| (2) Indoor outlet air wet-bulb temperature:  | °C [WB] |           |
| (3) Outdoor intake air dry-bulb temperature: | °C [DB] |           |
| (4) Total input:                             | W       |           |
| (5) Indoor intake air dry-bulb temperature:  | °C [DB] | } Heating |
| (6) Outdoor intake air wet-bulb temperature: | °C [WB] |           |
| (7) Total input:                             | W       |           |

Indoor air wet and dry bulb temperature difference on the left side of the following chart shows the difference between the indoor intake air wet and dry bulb temperature and the indoor outlet air wet and dry bulb temperature for your reference at service.

**How to measure the indoor air wet and dry bulb temperature difference**

- Attach at least 2 sets of wet and dry bulb thermometers to the indoor air intake as shown in the figure, and at least 2 sets of wet and dry bulb thermometers to the indoor air outlet. The thermometers must be attached to the position where air speed is high.
- Attach at least 2 sets of wet and dry bulb thermometers to the outdoor air intake. Cover the thermometers to prevent direct rays of the sun.
- Check that the air filter is cleaned.
- Open windows and doors of room.
- Press the EMERGENCY OPERATION switch once (twice) to start the EMERGENCY COOL (HEAT) MODE.
- When system stabilizes after more than 15 minutes, measure temperature and take an average temperature.
- 10 minutes later, measure temperature again and check that the temperature does not change.

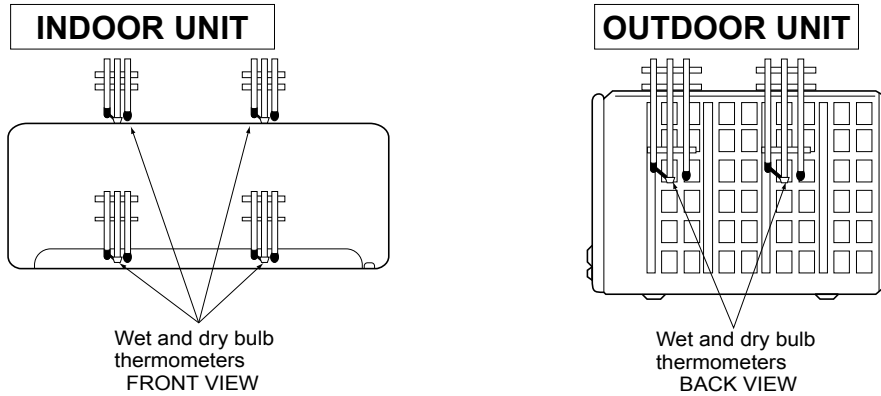

**8-1. CAPACITY AND INPUT CURVES**

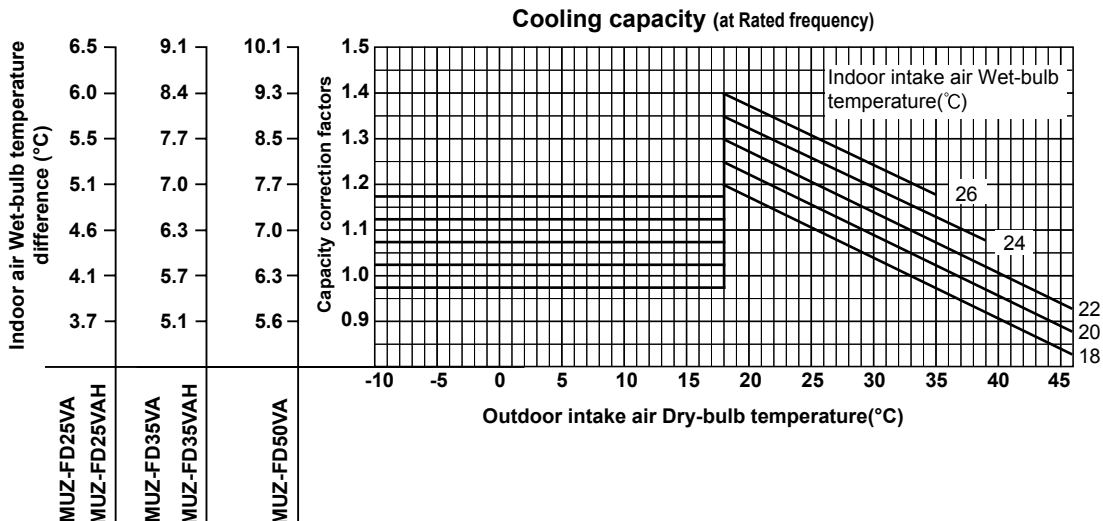



**Total input (Cooling : at Rated frequency)**

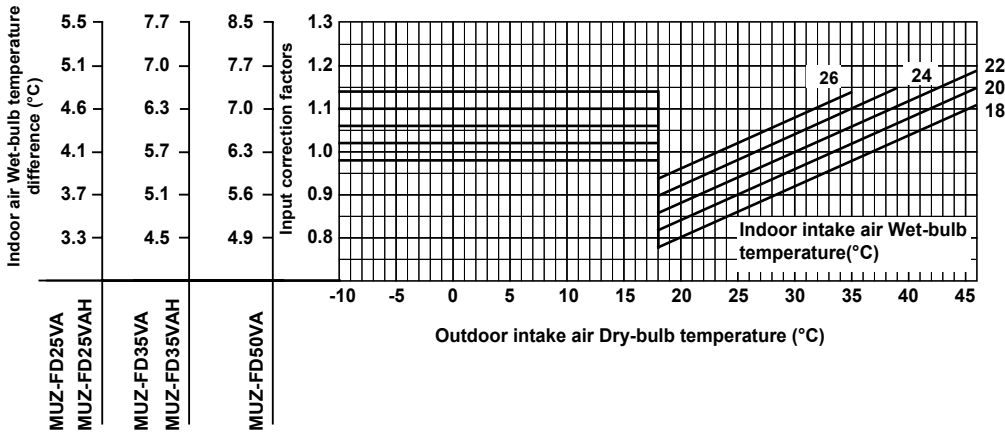

**Heating capacity (at Rated frequency)**

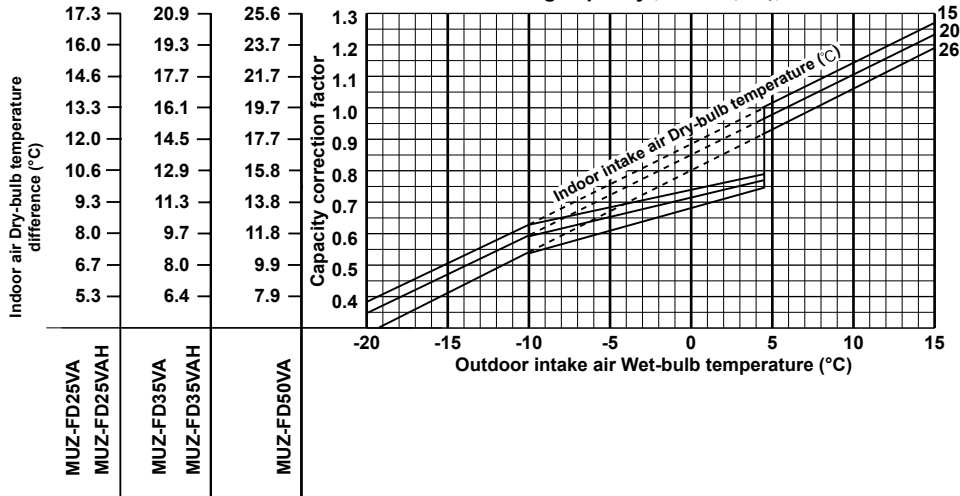

**Total input (Heating : at Rated frequency)**

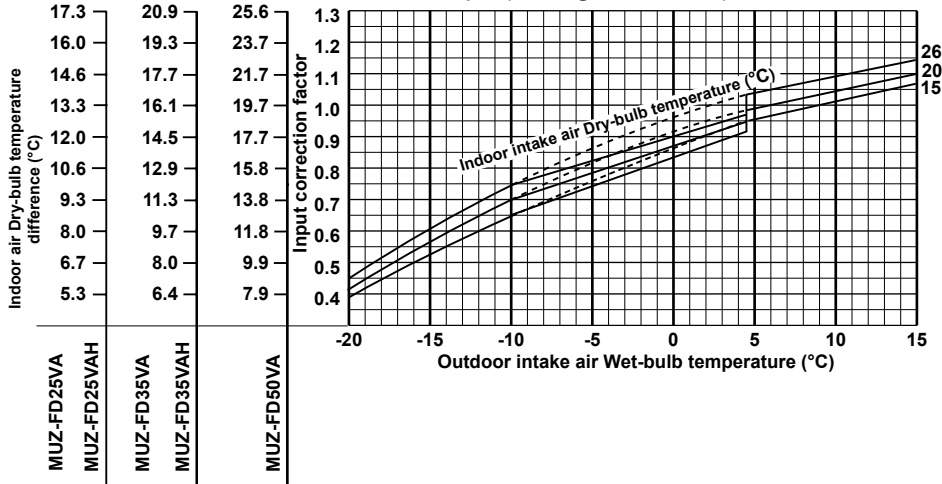

**NOTE:** The above broken lines are for the heating operation without any frost and defrost operation.

## 8-2. CAPACITY AND INPUT CORRECTION BY OPERATIONAL FREQUENCY OF COMPRESSOR

### MUZ-FD25VA MUZ-FD25VAH

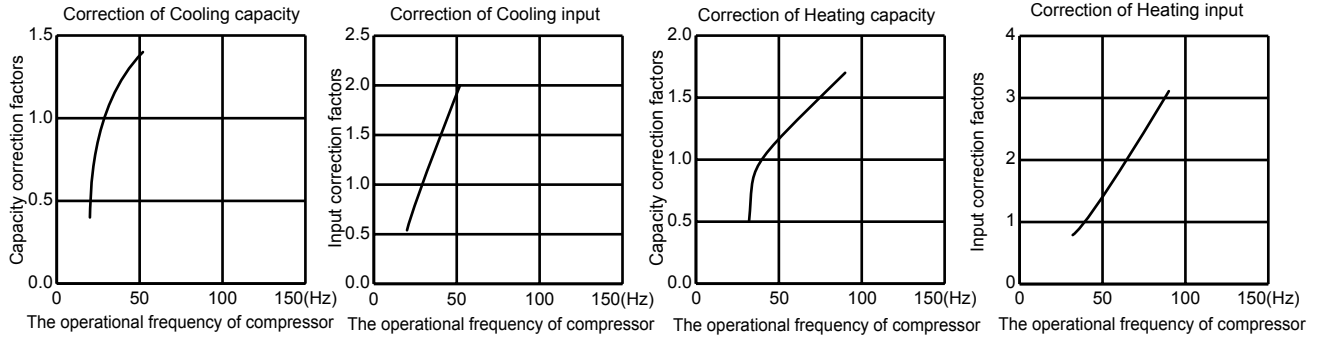

### MUZ-FD35VA

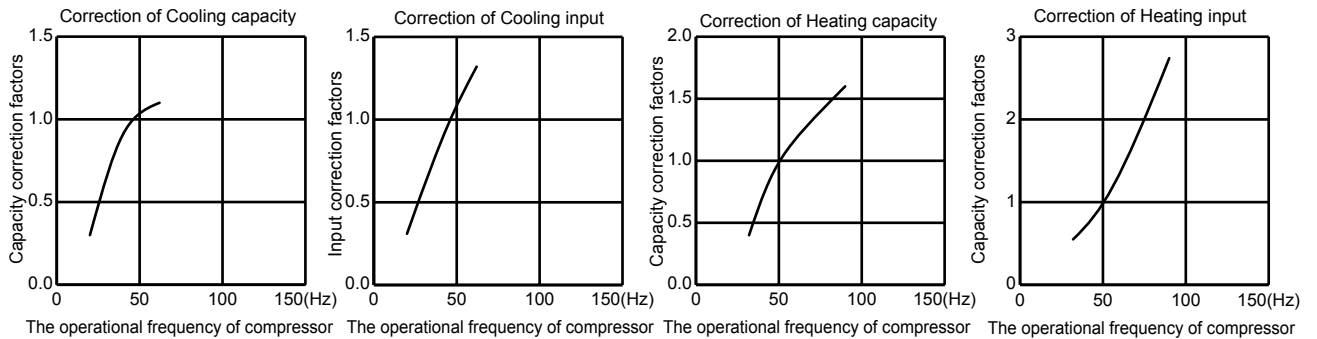

### MUZ-FD35VAH

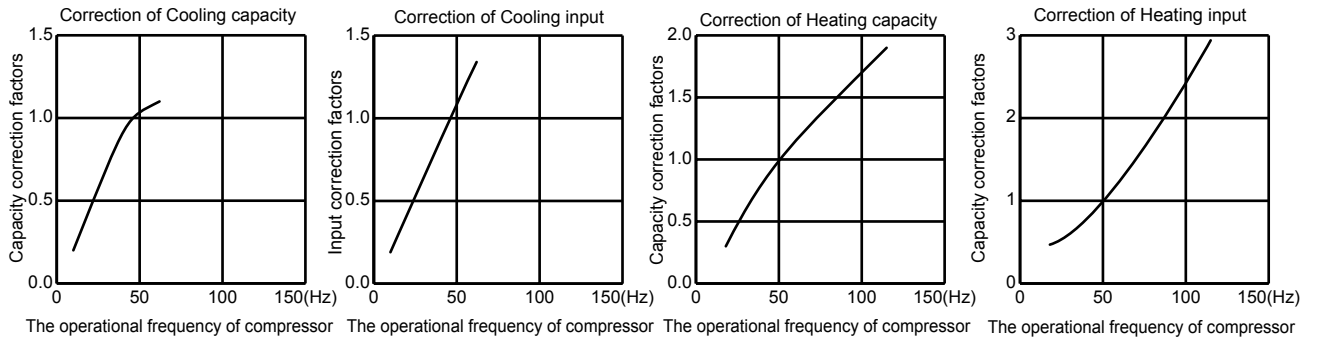

### MUZ-FD50VA

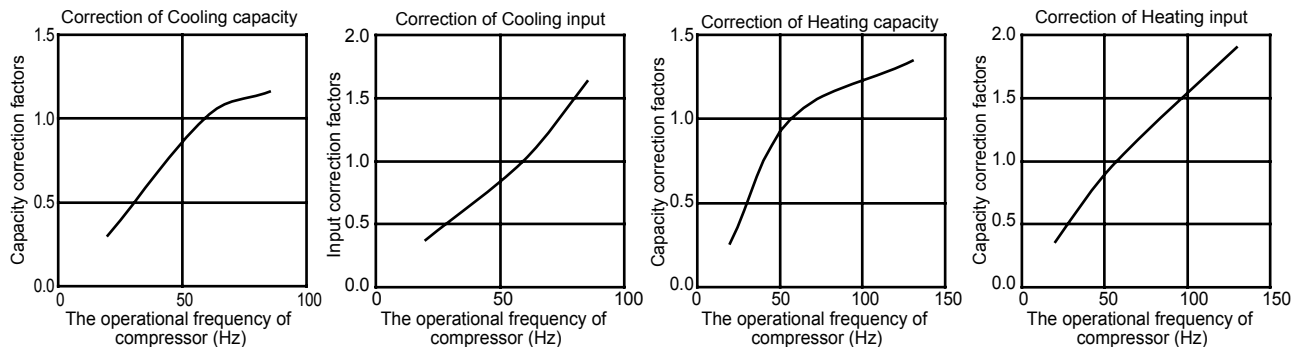

### 8-3. TEST RUN OPERATION (How to operate fixed-frequency operation)

1. Press EMERGENCY OPERATION switch to start COOL or HEAT mode (COOL: Press once, HEAT: Press twice).
2. Test run operation starts and continues to operate for 30 minutes.
3. Compressor operates at rated frequency in COOL mode or 58 Hz in HEAT mode.
4. Indoor fan operates at High speed.
5. After 30 minutes, test run operation finishes and EMERGENCY OPERATION starts (operation frequency of compressor varies).
6. To cancel test run operation (EMERGENCY OPERATION), press EMERGENCY OPERATION switch or any button on remote controller.

### 8-4. OUTDOOR LOW PRESSURE AND OUTDOOR UNIT CURRENT

#### COOL operation

- ① Both indoor and outdoor unit are under the same temperature/humidity condition.
- ② Operation: TEST RUN OPERATION (Refer to 8-3.)

Dry-bulb temperature (°C)	Relative humidity (%)
20	50
25	60
30	70

#### Outdoor low pressure

**MUZ-FD25VA MUZ-FD25VAH**

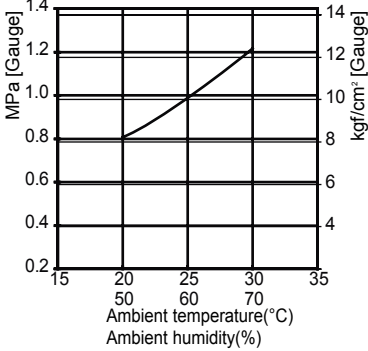

**MUZ-FD35VA**

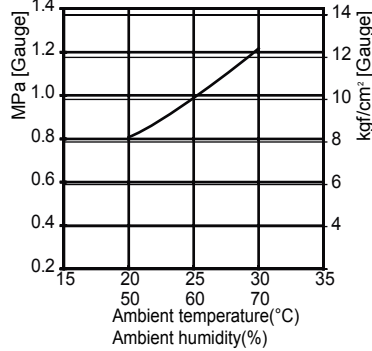

**MUZ-FD35VAH**

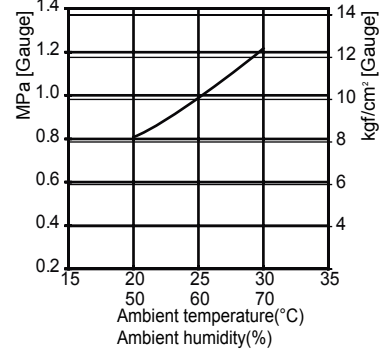

**MUZ-FD50VA**

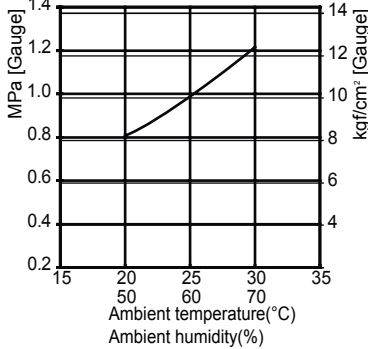

#### NOTE:

The unit of pressure has been changed to MPa on the international system of units (SI unit system)  
 The conversion factor is: **1 (MPa [Gauge]) = 10.2 (kgf/cm² [Gauge])**

### Outdoor unit current

**MUZ-FD25VA MUZ-FD25VAH**

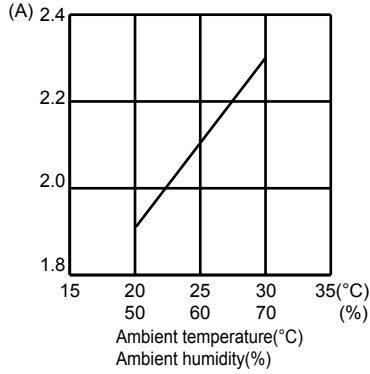

**MUZ-FD35VA**

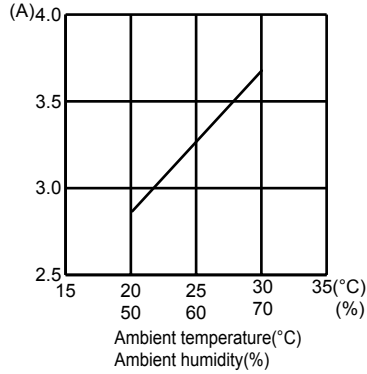

**MUZ-FD35VAH**

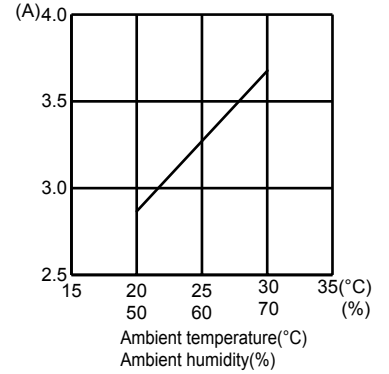

**MUZ-FD50VA**

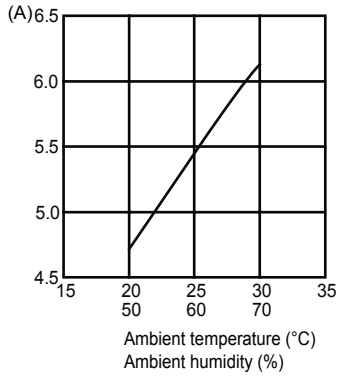

### HEAT operation

① Condition:

	Indoor	Outdoor			
Dry bulb temperature (°C)	20.0	2	7	15	20.0
Wet bulb temperature (°C)	14.5	1	6	12	14.5

② Operation: Test run operation (Refer to 8-3.)

### Outdoor unit current

**MUZ-FD25VA MUZ-FD25VAH**

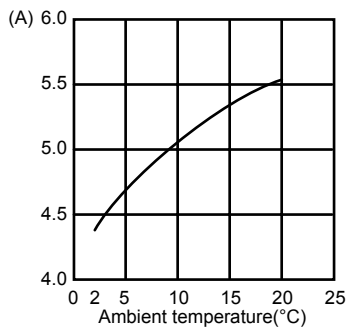

**MUZ-FD35VA**

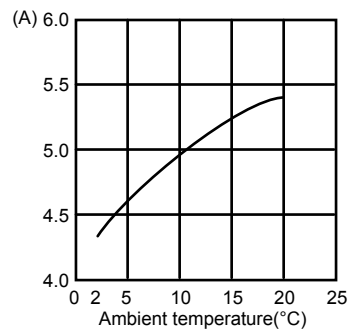

**MUZ-FD35VAH**

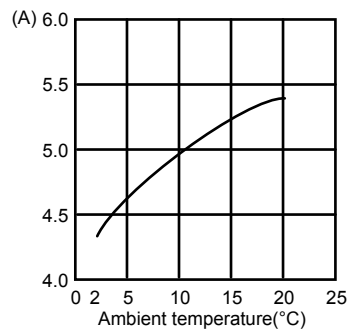

**MUZ-FD50VA**

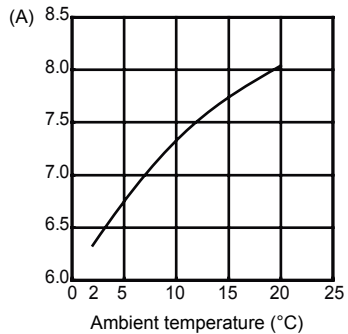

**PERFORMANCE DATA COOL operation at Rated frequency**

**MUZ-FD25VA MUZ-FD25VAH**

CAPACITY: 2.5 kW

SHF: 0.85

INPUT: 485 W

INDOOR DB (°C)	INDOOR WB (°C)	OUTDOOR DB (°C)															
		21				25				27				30			
		Q	SHC	SHF	INPUT	Q	SHC	SHF	INPUT	Q	SHC	SHF	INPUT	Q	SHC	SHF	INPUT
21	18	2.94	1.97	0.67	388	2.81	1.88	0.67	407	2.70	1.81	0.67	427	2.60	1.74	0.67	446
21	20	3.06	1.68	0.55	407	2.94	1.62	0.55	432	2.85	1.57	0.55	441	2.75	1.51	0.55	461
22	18	2.94	2.09	0.71	388	2.81	2.00	0.71	407	2.70	1.92	0.71	427	2.60	1.85	0.71	446
22	20	3.06	1.81	0.59	407	2.94	1.73	0.59	432	2.85	1.68	0.59	441	2.75	1.62	0.59	461
22	22	3.19	1.50	0.47	422	3.08	1.45	0.47	449	3.00	1.41	0.47	461	2.88	1.35	0.47	480
23	18	2.94	2.20	0.75	388	2.81	2.11	0.75	407	2.70	2.03	0.75	427	2.60	1.95	0.75	446
23	20	3.06	1.93	0.63	407	2.94	1.85	0.63	432	2.85	1.80	0.63	441	2.75	1.73	0.63	461
23	22	3.19	1.63	0.51	422	3.08	1.57	0.51	449	3.00	1.53	0.51	461	2.88	1.47	0.51	480
24	18	2.94	2.32	0.79	388	2.81	2.22	0.79	407	2.70	2.13	0.79	427	2.60	2.05	0.79	446
24	20	3.06	2.05	0.67	407	2.94	1.97	0.67	432	2.85	1.91	0.67	441	2.75	1.84	0.67	461
24	22	3.19	1.75	0.55	422	3.08	1.69	0.55	449	3.00	1.65	0.55	461	2.88	1.58	0.55	480
24	24	3.35	1.44	0.43	441	3.23	1.39	0.43	466	3.15	1.35	0.43	480	3.05	1.31	0.43	504
25	18	2.94	2.44	0.83	388	2.81	2.33	0.83	407	2.70	2.24	0.83	427	2.60	2.16	0.83	446
25	20	3.06	2.17	0.71	407	2.94	2.09	0.71	432	2.85	2.02	0.71	441	2.75	1.95	0.71	461
25	22	3.19	1.88	0.59	422	3.08	1.81	0.59	449	3.00	1.77	0.59	461	2.88	1.70	0.59	480
25	24	3.35	1.57	0.47	441	3.23	1.52	0.47	466	3.15	1.48	0.47	480	3.05	1.43	0.47	504
26	18	2.94	2.56	0.87	388	2.81	2.45	0.87	407	2.70	2.35	0.87	427	2.60	2.26	0.87	446
26	20	3.06	2.30	0.75	407	2.94	2.20	0.75	432	2.85	2.14	0.75	441	2.75	2.06	0.75	461
26	22	3.19	2.01	0.63	422	3.08	1.94	0.63	449	3.00	1.89	0.63	461	2.88	1.81	0.63	480
26	24	3.35	1.71	0.51	441	3.23	1.64	0.51	466	3.15	1.61	0.51	480	3.05	1.56	0.51	504
26	26	3.45	1.35	0.39	466	3.35	1.31	0.39	490	3.30	1.29	0.39	504	3.20	1.25	0.39	519
27	18	2.94	2.67	0.91	388	2.81	2.56	0.91	407	2.70	2.46	0.91	427	2.60	2.37	0.91	446
27	20	3.06	2.42	0.79	407	2.94	2.32	0.79	432	2.85	2.25	0.79	441	2.75	2.17	0.79	461
27	22	3.19	2.14	0.67	422	3.08	2.06	0.67	449	3.00	2.01	0.67	461	2.88	1.93	0.67	480
27	24	3.35	1.84	0.55	441	3.23	1.77	0.55	466	3.15	1.73	0.55	480	3.05	1.68	0.55	504
27	26	3.45	1.48	0.43	466	3.35	1.44	0.43	490	3.30	1.42	0.43	504	3.20	1.38	0.43	519
28	18	2.94	2.79	0.95	388	2.81	2.67	0.95	407	2.70	2.57	0.95	427	2.60	2.47	0.95	446
28	20	3.06	2.54	0.83	407	2.94	2.44	0.83	432	2.85	2.37	0.83	441	2.75	2.28	0.83	461
28	22	3.19	2.26	0.71	422	3.08	2.18	0.71	449	3.00	2.13	0.71	461	2.88	2.04	0.71	480
28	24	3.35	1.98	0.59	441	3.23	1.90	0.59	466	3.15	1.86	0.59	480	3.05	1.80	0.59	504
28	26	3.45	1.62	0.47	466	3.35	1.57	0.47	490	3.30	1.55	0.47	504	3.20	1.50	0.47	519
29	18	2.94	2.91	0.99	388	2.81	2.78	0.99	407	2.70	2.67	0.99	427	2.60	2.57	0.99	446
29	20	3.06	2.66	0.87	407	2.94	2.56	0.87	432	2.85	2.48	0.87	441	2.75	2.39	0.87	461
29	22	3.19	2.39	0.75	422	3.08	2.31	0.75	449	3.00	2.25	0.75	461	2.88	2.16	0.75	480
29	24	3.35	2.11	0.63	441	3.23	2.03	0.63	466	3.15	1.98	0.63	480	3.05	1.92	0.63	504
29	26	3.45	1.76	0.51	466	3.35	1.71	0.51	490	3.30	1.68	0.51	504	3.20	1.63	0.51	519
30	18	2.94	2.94	1.00	388	2.81	2.81	1.00	407	2.70	2.70	1.00	427	2.60	2.60	1.00	446
30	20	3.06	2.79	0.91	407	2.94	2.67	0.91	432	2.85	2.59	0.91	441	2.75	2.50	0.91	461
30	22	3.19	2.52	0.79	422	3.08	2.43	0.79	449	3.00	2.37	0.79	461	2.88	2.27	0.79	480
30	24	3.35	2.24	0.67	441	3.23	2.16	0.67	466	3.15	2.11	0.67	480	3.05	2.04	0.67	504
30	26	3.45	1.90	0.55	466	3.35	1.84	0.55	490	3.30	1.82	0.55	504	3.20	1.76	0.55	519
31	18	2.94	2.94	1.00	388	2.81	2.81	1.00	407	2.70	2.70	1.00	427	2.60	2.60	1.00	446
31	20	3.06	2.91	0.95	407	2.94	2.79	0.95	432	2.85	2.71	0.95	441	2.75	2.61	0.95	461
31	22	3.19	2.65	0.83	422	3.08	2.55	0.83	449	3.00	2.49	0.83	461	2.88	2.39	0.83	480
31	24	3.35	2.38	0.71	441	3.23	2.29	0.71	466	3.15	2.24	0.71	480	3.05	2.17	0.71	504
31	26	3.45	2.04	0.59	466	3.35	1.98	0.59	490	3.30	1.95	0.59	504	3.20	1.89	0.59	519
32	18	2.94	2.94	1.00	388	2.81	2.81	1.00	407	2.70	2.70	1.00	427	2.60	2.60	1.00	446
32	20	3.06	3.03	0.99	407	2.94	2.91	0.99	432	2.85	2.82	0.99	441	2.75	2.72	0.99	461
32	22	3.19	2.77	0.87	422	3.08	2.68	0.87	449	3.00	2.61	0.87	461	2.88	2.50	0.87	480
32	24	3.35	2.51	0.75	441	3.23	2.42	0.75	466	3.15	2.36	0.75	480	3.05	2.29	0.75	504
32	26	3.45	2.17	0.63	466	3.35	2.11	0.63	490	3.30	2.08	0.63	504	3.20	2.02	0.63	519

**NOTE** Q : Total capacity (kW) SHF : Sensible heat factor DB : Dry-bulb temperature  
 SHC : Sensible heat capacity (kW) INPUT : Total power input (W) WB : Wet-bulb temperature

**PERFORMANCE DATA COOL operation at Rated frequency**  
**MUZ-FD25VA MUZ-FD25VAH**

CAPACITY: 2.5 kW SHF: 0.85 INPUT: 485 W

INDOOR DB (°C)	INDOOR WB (°C)	OUTDOOR DB (°C)											
		35				40				46			
		Q	SHC	SHF	INPUT	Q	SHC	SHF	INPUT	Q	SHC	SHF	INPUT
21	18	2.45	1.64	0.67	475	2.25	1.51	0.67	504	2.08	1.39	0.67	524
21	20	2.58	1.42	0.55	495	2.40	1.32	0.55	519	2.23	1.22	0.55	548
22	18	2.45	1.74	0.71	475	2.25	1.60	0.71	504	2.08	1.47	0.71	524
22	20	2.58	1.52	0.59	495	2.40	1.42	0.59	519	2.23	1.31	0.59	548
22	22	2.73	1.28	0.47	514	2.55	1.20	0.47	543	2.38	1.12	0.47	563
23	18	2.45	1.84	0.75	475	2.25	1.69	0.75	504	2.08	1.56	0.75	524
23	20	2.58	1.62	0.63	495	2.40	1.51	0.63	519	2.23	1.40	0.63	548
23	22	2.73	1.39	0.51	514	2.55	1.30	0.51	543	2.38	1.21	0.51	563
24	18	2.45	1.94	0.79	475	2.25	1.78	0.79	504	2.08	1.64	0.79	524
24	20	2.58	1.73	0.67	495	2.40	1.61	0.67	519	2.23	1.49	0.67	548
24	22	2.73	1.50	0.55	514	2.55	1.40	0.55	543	2.38	1.31	0.55	563
24	24	2.88	1.24	0.43	534	2.70	1.16	0.43	558	2.55	1.10	0.43	582
25	18	2.45	2.03	0.83	475	2.25	1.87	0.83	504	2.08	1.72	0.83	524
25	20	2.58	1.83	0.71	495	2.40	1.70	0.71	519	2.23	1.58	0.71	548
25	22	2.73	1.61	0.59	514	2.55	1.50	0.59	543	2.38	1.40	0.59	563
25	24	2.88	1.35	0.47	534	2.70	1.27	0.47	558	2.55	1.20	0.47	582
26	18	2.45	2.13	0.87	475	2.25	1.96	0.87	504	2.08	1.81	0.87	524
26	20	2.58	1.93	0.75	495	2.40	1.80	0.75	519	2.23	1.67	0.75	548
26	22	2.73	1.72	0.63	514	2.55	1.61	0.63	543	2.38	1.50	0.63	563
26	24	2.88	1.47	0.51	534	2.70	1.38	0.51	558	2.55	1.30	0.51	582
26	26	3.03	1.18	0.39	553	2.85	1.11	0.39	577	2.68	1.04	0.39	601
27	18	2.45	2.23	0.91	475	2.25	2.05	0.91	504	2.08	1.89	0.91	524
27	20	2.58	2.03	0.79	495	2.40	1.90	0.79	519	2.23	1.76	0.79	548
27	22	2.73	1.83	0.67	514	2.55	1.71	0.67	543	2.38	1.59	0.67	563
27	24	2.88	1.58	0.55	534	2.70	1.49	0.55	558	2.55	1.40	0.55	582
27	26	3.03	1.30	0.43	553	2.85	1.23	0.43	577	2.68	1.15	0.43	601
28	18	2.45	2.33	0.95	475	2.25	2.14	0.95	504	2.08	1.97	0.95	524
28	20	2.58	2.14	0.83	495	2.40	1.99	0.83	519	2.23	1.85	0.83	548
28	22	2.73	1.93	0.71	514	2.55	1.81	0.71	543	2.38	1.69	0.71	563
28	24	2.88	1.70	0.59	534	2.70	1.59	0.59	558	2.55	1.50	0.59	582
28	26	3.03	1.42	0.47	553	2.85	1.34	0.47	577	2.68	1.26	0.47	601
29	18	2.45	2.43	0.99	475	2.25	2.23	0.99	504	2.08	2.05	0.99	524
29	20	2.58	2.24	0.87	495	2.40	2.09	0.87	519	2.23	1.94	0.87	548
29	22	2.73	2.04	0.75	514	2.55	1.91	0.75	543	2.38	1.78	0.75	563
29	24	2.88	1.81	0.63	534	2.70	1.70	0.63	558	2.55	1.61	0.63	582
29	26	3.03	1.54	0.51	553	2.85	1.45	0.51	577	2.68	1.36	0.51	601
30	18	2.45	2.45	1.00	475	2.25	2.25	1.00	504	2.08	2.08	1.00	524
30	20	2.58	2.34	0.91	495	2.40	2.18	0.91	519	2.23	2.02	0.91	548
30	22	2.73	2.15	0.79	514	2.55	2.01	0.79	543	2.38	1.88	0.79	563
30	24	2.88	1.93	0.67	534	2.70	1.81	0.67	558	2.55	1.71	0.67	582
30	26	3.03	1.66	0.55	553	2.85	1.57	0.55	577	2.68	1.47	0.55	601
31	18	2.45	2.45	1.00	475	2.25	2.25	1.00	504	2.08	2.08	1.00	524
31	20	2.58	2.45	0.95	495	2.40	2.28	0.95	519	2.23	2.11	0.95	548
31	22	2.73	2.26	0.83	514	2.55	2.12	0.83	543	2.38	1.97	0.83	563
31	24	2.88	2.04	0.71	534	2.70	1.92	0.71	558	2.55	1.81	0.71	582
31	26	3.03	1.78	0.59	553	2.85	1.68	0.59	577	2.68	1.58	0.59	601
32	18	2.45	2.45	1.00	475	2.25	2.25	1.00	504	2.08	2.08	1.00	524
32	20	2.58	2.55	0.99	495	2.40	2.38	0.99	519	2.23	2.20	0.99	548
32	22	2.73	2.37	0.87	514	2.55	2.22	0.87	543	2.38	2.07	0.87	563
32	24	2.88	2.16	0.75	534	2.70	2.03	0.75	558	2.55	1.91	0.75	582
32	26	3.03	1.91	0.63	553	2.85	1.80	0.63	577	2.68	1.69	0.63	601

**NOTE** Q : Total capacity (kW) SHF : Sensible heat factor DB : Dry-bulb temperature  
 SHC : Sensible heat capacity (kW) INPUT : Total power input (W) WB : Wet-bulb temperature

**PERFORMANCE DATA COOL operation at Rated frequency**

**MUZ-FD35VA**

CAPACITY: 3.5 kW

SHF: 0.85

INPUT: 850 W

INDOOR DB (°C)	INDOOR WB (°C)	OUTDOOR DB (°C)															
		21				25				27				30			
		Q	SHC	SHF	INPUT	Q	SHC	SHF	INPUT	Q	SHC	SHF	INPUT	Q	SHC	SHF	INPUT
21	18	4.11	2.76	0.67	680	3.94	2.64	0.67	714	3.78	2.53	0.67	748	3.64	2.44	0.67	782
21	20	4.29	2.36	0.55	714	4.11	2.26	0.55	757	3.99	2.19	0.55	774	3.85	2.12	0.55	808
22	18	4.11	2.92	0.71	680	3.94	2.80	0.71	714	3.78	2.68	0.71	748	3.64	2.58	0.71	782
22	20	4.29	2.53	0.59	714	4.11	2.43	0.59	757	3.99	2.35	0.59	774	3.85	2.27	0.59	808
22	22	4.46	2.10	0.47	740	4.31	2.02	0.47	786	4.20	1.97	0.47	808	4.03	1.89	0.47	842
23	18	4.11	3.08	0.75	680	3.94	2.95	0.75	714	3.78	2.84	0.75	748	3.64	2.73	0.75	782
23	20	4.29	2.70	0.63	714	4.11	2.59	0.63	757	3.99	2.51	0.63	774	3.85	2.43	0.63	808
23	22	4.46	2.28	0.51	740	4.31	2.20	0.51	786	4.20	2.14	0.51	808	4.03	2.05	0.51	842
24	18	4.11	3.25	0.79	680	3.94	3.11	0.79	714	3.78	2.99	0.79	748	3.64	2.88	0.79	782
24	20	4.29	2.87	0.67	714	4.11	2.76	0.67	757	3.99	2.67	0.67	774	3.85	2.58	0.67	808
24	22	4.46	2.45	0.55	740	4.31	2.37	0.55	786	4.20	2.31	0.55	808	4.03	2.21	0.55	842
24	24	4.69	2.02	0.43	774	4.52	1.94	0.43	816	4.41	1.90	0.43	842	4.27	1.84	0.43	884
25	18	4.11	3.41	0.83	680	3.94	3.27	0.83	714	3.78	3.14	0.83	748	3.64	3.02	0.83	782
25	20	4.29	3.04	0.71	714	4.11	2.92	0.71	757	3.99	2.83	0.71	774	3.85	2.73	0.71	808
25	22	4.46	2.63	0.59	740	4.31	2.54	0.59	786	4.20	2.48	0.59	808	4.03	2.37	0.59	842
25	24	4.69	2.20	0.47	774	4.52	2.12	0.47	816	4.41	2.07	0.47	842	4.27	2.01	0.47	884
26	18	4.11	3.58	0.87	680	3.94	3.43	0.87	714	3.78	3.29	0.87	748	3.64	3.17	0.87	782
26	20	4.29	3.22	0.75	714	4.11	3.08	0.75	757	3.99	2.99	0.75	774	3.85	2.89	0.75	808
26	22	4.46	2.81	0.63	740	4.31	2.71	0.63	786	4.20	2.65	0.63	808	4.03	2.54	0.63	842
26	24	4.69	2.39	0.51	774	4.52	2.30	0.51	816	4.41	2.25	0.51	842	4.27	2.18	0.51	884
26	26	4.83	1.88	0.39	816	4.69	1.83	0.39	859	4.62	1.80	0.39	884	4.48	1.75	0.39	910
27	18	4.11	3.74	0.91	680	3.94	3.58	0.91	714	3.78	3.44	0.91	748	3.64	3.31	0.91	782
27	20	4.29	3.39	0.79	714	4.11	3.25	0.79	757	3.99	3.15	0.79	774	3.85	3.04	0.79	808
27	22	4.46	2.99	0.67	740	4.31	2.88	0.67	786	4.20	2.81	0.67	808	4.03	2.70	0.67	842
27	24	4.69	2.58	0.55	774	4.52	2.48	0.55	816	4.41	2.43	0.55	842	4.27	2.35	0.55	884
27	26	4.83	2.08	0.43	816	4.69	2.02	0.43	859	4.62	1.99	0.43	884	4.48	1.93	0.43	910
28	18	4.11	3.91	0.95	680	3.94	3.74	0.95	714	3.78	3.59	0.95	748	3.64	3.46	0.95	782
28	20	4.29	3.56	0.83	714	4.11	3.41	0.83	757	3.99	3.31	0.83	774	3.85	3.20	0.83	808
28	22	4.46	3.17	0.71	740	4.31	3.06	0.71	786	4.20	2.98	0.71	808	4.03	2.86	0.71	842
28	24	4.69	2.77	0.59	774	4.52	2.66	0.59	816	4.41	2.60	0.59	842	4.27	2.52	0.59	884
28	26	4.83	2.27	0.47	816	4.69	2.20	0.47	859	4.62	2.17	0.47	884	4.48	2.11	0.47	910
29	18	4.11	4.07	0.99	680	3.94	3.90	0.99	714	3.78	3.74	0.99	748	3.64	3.60	0.99	782
29	20	4.29	3.73	0.87	714	4.11	3.58	0.87	757	3.99	3.47	0.87	774	3.85	3.35	0.87	808
29	22	4.46	3.35	0.75	740	4.31	3.23	0.75	786	4.20	3.15	0.75	808	4.03	3.02	0.75	842
29	24	4.69	2.95	0.63	774	4.52	2.84	0.63	816	4.41	2.78	0.63	842	4.27	2.69	0.63	884
29	26	4.83	2.46	0.51	816	4.69	2.39	0.51	859	4.62	2.36	0.51	884	4.48	2.28	0.51	910
30	18	4.11	4.11	1.00	680	3.94	3.94	1.00	714	3.78	3.78	1.00	748	3.64	3.64	1.00	782
30	20	4.29	3.90	0.91	714	4.11	3.74	0.91	757	3.99	3.63	0.91	774	3.85	3.50	0.91	808
30	22	4.46	3.53	0.79	740	4.31	3.40	0.79	786	4.20	3.32	0.79	808	4.03	3.18	0.79	842
30	24	4.69	3.14	0.67	774	4.52	3.03	0.67	816	4.41	2.95	0.67	842	4.27	2.86	0.67	884
30	26	4.83	2.66	0.55	816	4.69	2.58	0.55	859	4.62	2.54	0.55	884	4.48	2.46	0.55	910
31	18	4.11	4.11	1.00	680	3.94	3.94	1.00	714	3.78	3.78	1.00	748	3.64	3.64	1.00	782
31	20	4.29	4.07	0.95	714	4.11	3.91	0.95	757	3.99	3.79	0.95	774	3.85	3.66	0.95	808
31	22	4.46	3.70	0.83	740	4.31	3.57	0.83	786	4.20	3.49	0.83	808	4.03	3.34	0.83	842
31	24	4.69	3.33	0.71	774	4.52	3.21	0.71	816	4.41	3.13	0.71	842	4.27	3.03	0.71	884
31	26	4.83	2.85	0.59	816	4.69	2.77	0.59	859	4.62	2.73	0.59	884	4.48	2.64	0.59	910
32	18	4.11	4.11	1.00	680	3.94	3.94	1.00	714	3.78	3.78	1.00	748	3.64	3.64	1.00	782
32	20	4.29	4.24	0.99	714	4.11	4.07	0.99	757	3.99	3.95	0.99	774	3.85	3.81	0.99	808
32	22	4.46	3.88	0.87	740	4.31	3.75	0.87	786	4.20	3.65	0.87	808	4.03	3.50	0.87	842
32	24	4.69	3.52	0.75	774	4.52	3.39	0.75	816	4.41	3.31	0.75	842	4.27	3.20	0.75	884
32	26	4.83	3.04	0.63	816	4.69	2.95	0.63	859	4.62	2.91	0.63	884	4.48	2.82	0.63	910

**NOTE** Q : Total capacity (kW) SHF : Sensible heat factor DB : Dry-bulb temperature  
 SHC : Sensible heat capacity (kW) INPUT : Total power input (W) WB : Wet-bulb temperature

**PERFORMANCE DATA COOL operation at Rated frequency**

**MUZ-FD35VA**

CAPACITY: 3.5 kW

SHF: 0.85

INPUT: 850 W

INDOOR DB (°C)	INDOOR WB (°C)	OUTDOOR DB (°C)											
		35				40				46			
		Q	SHC	SHF	INPUT	Q	SHC	SHF	INPUT	Q	SHC	SHF	INPUT
21	18	3.43	2.30	0.67	833	3.15	2.11	0.67	884	2.91	1.95	0.67	918
21	20	3.61	1.98	0.55	867	3.36	1.85	0.55	910	3.12	1.71	0.55	961
22	18	3.43	2.44	0.71	833	3.15	2.24	0.71	884	2.91	2.06	0.71	918
22	20	3.61	2.13	0.59	867	3.36	1.98	0.59	910	3.12	1.84	0.59	961
22	22	3.82	1.79	0.47	901	3.57	1.68	0.47	952	3.33	1.56	0.47	986
23	18	3.43	2.57	0.75	833	3.15	2.36	0.75	884	2.91	2.18	0.75	918
23	20	3.61	2.27	0.63	867	3.36	2.12	0.63	910	3.12	1.96	0.63	961
23	22	3.82	1.95	0.51	901	3.57	1.82	0.51	952	3.33	1.70	0.51	986
24	18	3.43	2.71	0.79	833	3.15	2.49	0.79	884	2.91	2.29	0.79	918
24	20	3.61	2.42	0.67	867	3.36	2.25	0.67	910	3.12	2.09	0.67	961
24	22	3.82	2.10	0.55	901	3.57	1.96	0.55	952	3.33	1.83	0.55	986
24	24	4.03	1.73	0.43	935	3.78	1.63	0.43	978	3.57	1.54	0.43	1020
25	18	3.43	2.85	0.83	833	3.15	2.61	0.83	884	2.91	2.41	0.83	918
25	20	3.61	2.56	0.71	867	3.36	2.39	0.71	910	3.12	2.21	0.71	961
25	22	3.82	2.25	0.59	901	3.57	2.11	0.59	952	3.33	1.96	0.59	986
25	24	4.03	1.89	0.47	935	3.78	1.78	0.47	978	3.57	1.68	0.47	1020
26	18	3.43	2.98	0.87	833	3.15	2.74	0.87	884	2.91	2.53	0.87	918
26	20	3.61	2.70	0.75	867	3.36	2.52	0.75	910	3.12	2.34	0.75	961
26	22	3.82	2.40	0.63	901	3.57	2.25	0.63	952	3.33	2.09	0.63	986
26	24	4.03	2.05	0.51	935	3.78	1.93	0.51	978	3.57	1.82	0.51	1020
26	26	4.24	1.65	0.39	969	3.99	1.56	0.39	1012	3.75	1.46	0.39	1054
27	18	3.43	3.12	0.91	833	3.15	2.87	0.91	884	2.91	2.64	0.91	918
27	20	3.61	2.85	0.79	867	3.36	2.65	0.79	910	3.12	2.46	0.79	961
27	22	3.82	2.56	0.67	901	3.57	2.39	0.67	952	3.33	2.23	0.67	986
27	24	4.03	2.21	0.55	935	3.78	2.08	0.55	978	3.57	1.96	0.55	1020
27	26	4.24	1.82	0.43	969	3.99	1.72	0.43	1012	3.75	1.61	0.43	1054
28	18	3.43	3.26	0.95	833	3.15	2.99	0.95	884	2.91	2.76	0.95	918
28	20	3.61	2.99	0.83	867	3.36	2.79	0.83	910	3.12	2.59	0.83	961
28	22	3.82	2.71	0.71	901	3.57	2.53	0.71	952	3.33	2.36	0.71	986
28	24	4.03	2.37	0.59	935	3.78	2.23	0.59	978	3.57	2.11	0.59	1020
28	26	4.24	1.99	0.47	969	3.99	1.88	0.47	1012	3.75	1.76	0.47	1054
29	18	3.43	3.40	0.99	833	3.15	3.12	0.99	884	2.91	2.88	0.99	918
29	20	3.61	3.14	0.87	867	3.36	2.92	0.87	910	3.12	2.71	0.87	961
29	22	3.82	2.86	0.75	901	3.57	2.68	0.75	952	3.33	2.49	0.75	986
29	24	4.03	2.54	0.63	935	3.78	2.38	0.63	978	3.57	2.25	0.63	1020
29	26	4.24	2.16	0.51	969	3.99	2.03	0.51	1012	3.75	1.91	0.51	1054
30	18	3.43	3.43	1.00	833	3.15	3.15	1.00	884	2.91	2.91	1.00	918
30	20	3.61	3.28	0.91	867	3.36	3.06	0.91	910	3.12	2.83	0.91	961
30	22	3.82	3.01	0.79	901	3.57	2.82	0.79	952	3.33	2.63	0.79	986
30	24	4.03	2.70	0.67	935	3.78	2.53	0.67	978	3.57	2.39	0.67	1020
30	26	4.24	2.33	0.55	969	3.99	2.19	0.55	1012	3.75	2.06	0.55	1054
31	18	3.43	3.43	1.00	833	3.15	3.15	1.00	884	2.91	2.91	1.00	918
31	20	3.61	3.42	0.95	867	3.36	3.19	0.95	910	3.12	2.96	0.95	961
31	22	3.82	3.17	0.83	901	3.57	2.96	0.83	952	3.33	2.76	0.83	986
31	24	4.03	2.86	0.71	935	3.78	2.68	0.71	978	3.57	2.53	0.71	1020
31	26	4.24	2.50	0.59	969	3.99	2.35	0.59	1012	3.75	2.21	0.59	1054
32	18	3.43	3.43	1.00	833	3.15	3.15	1.00	884	2.91	2.91	1.00	918
32	20	3.61	3.57	0.99	867	3.36	3.33	0.99	910	3.12	3.08	0.99	961
32	22	3.82	3.32	0.87	901	3.57	3.11	0.87	952	3.33	2.89	0.87	986
32	24	4.03	3.02	0.75	935	3.78	2.84	0.75	978	3.57	2.68	0.75	1020
32	26	4.24	2.67	0.63	969	3.99	2.51	0.63	1012	3.75	2.36	0.63	1054

**NOTE** Q : Total capacity (kW) SHF : Sensible heat factor DB : Dry-bulb temperature  
 SHC : Sensible heat capacity (kW) INPUT : Total power input (W) WB : Wet-bulb temperature

**PERFORMANCE DATA COOL operation at Rated frequency**  
**MUZ-FD35VAH**

CAPACITY: 3.5 kW SHF: 0.85 INPUT: 835 W

INDOOR DB (°C)	INDOOR WB (°C)	OUTDOOR DB (°C)															
		21				25				27				30			
		Q	SHC	SHF	INPUT	Q	SHC	SHF	INPUT	Q	SHC	SHF	INPUT	Q	SHC	SHF	INPUT
21	18	4.11	2.76	0.67	668	3.94	2.64	0.67	701	3.78	2.53	0.67	735	3.64	2.44	0.67	768
21	20	4.29	2.36	0.55	701	4.11	2.26	0.55	743	3.99	2.19	0.55	760	3.85	2.12	0.55	793
22	18	4.11	2.92	0.71	668	3.94	2.80	0.71	701	3.78	2.68	0.71	735	3.64	2.58	0.71	768
22	20	4.29	2.53	0.59	701	4.11	2.43	0.59	743	3.99	2.35	0.59	760	3.85	2.27	0.59	793
22	22	4.46	2.10	0.47	726	4.31	2.02	0.47	772	4.20	1.97	0.47	793	4.03	1.89	0.47	827
23	18	4.11	3.08	0.75	668	3.94	2.95	0.75	701	3.78	2.84	0.75	735	3.64	2.73	0.75	768
23	20	4.29	2.70	0.63	701	4.11	2.59	0.63	743	3.99	2.51	0.63	760	3.85	2.43	0.63	793
23	22	4.46	2.28	0.51	726	4.31	2.20	0.51	772	4.20	2.14	0.51	793	4.03	2.05	0.51	827
24	18	4.11	3.25	0.79	668	3.94	3.11	0.79	701	3.78	2.99	0.79	735	3.64	2.88	0.79	768
24	20	4.29	2.87	0.67	701	4.11	2.76	0.67	743	3.99	2.67	0.67	760	3.85	2.58	0.67	793
24	22	4.46	2.45	0.55	726	4.31	2.37	0.55	772	4.20	2.31	0.55	793	4.03	2.21	0.55	827
24	24	4.69	2.02	0.43	760	4.52	1.94	0.43	802	4.41	1.90	0.43	827	4.27	1.84	0.43	868
25	18	4.11	3.41	0.83	668	3.94	3.27	0.83	701	3.78	3.14	0.83	735	3.64	3.02	0.83	768
25	20	4.29	3.04	0.71	701	4.11	2.92	0.71	743	3.99	2.83	0.71	760	3.85	2.73	0.71	793
25	22	4.46	2.63	0.59	726	4.31	2.54	0.59	772	4.20	2.48	0.59	793	4.03	2.37	0.59	827
25	24	4.69	2.20	0.47	760	4.52	2.12	0.47	802	4.41	2.07	0.47	827	4.27	2.01	0.47	868
26	18	4.11	3.58	0.87	668	3.94	3.43	0.87	701	3.78	3.29	0.87	735	3.64	3.17	0.87	768
26	20	4.29	3.22	0.75	701	4.11	3.08	0.75	743	3.99	2.99	0.75	760	3.85	2.89	0.75	793
26	22	4.46	2.81	0.63	726	4.31	2.71	0.63	772	4.20	2.65	0.63	793	4.03	2.54	0.63	827
26	24	4.69	2.39	0.51	760	4.52	2.30	0.51	802	4.41	2.25	0.51	827	4.27	2.18	0.51	868
26	26	4.83	1.88	0.39	802	4.69	1.83	0.39	843	4.62	1.80	0.39	868	4.48	1.75	0.39	893
27	18	4.11	3.74	0.91	668	3.94	3.58	0.91	701	3.78	3.44	0.91	735	3.64	3.31	0.91	768
27	20	4.29	3.39	0.79	701	4.11	3.25	0.79	743	3.99	3.15	0.79	760	3.85	3.04	0.79	793
27	22	4.46	2.99	0.67	726	4.31	2.88	0.67	772	4.20	2.81	0.67	793	4.03	2.70	0.67	827
27	24	4.69	2.58	0.55	760	4.52	2.48	0.55	802	4.41	2.43	0.55	827	4.27	2.35	0.55	868
27	26	4.83	2.08	0.43	802	4.69	2.02	0.43	843	4.62	1.99	0.43	868	4.48	1.93	0.43	893
28	18	4.11	3.91	0.95	668	3.94	3.74	0.95	701	3.78	3.59	0.95	735	3.64	3.46	0.95	768
28	20	4.29	3.56	0.83	701	4.11	3.41	0.83	743	3.99	3.31	0.83	760	3.85	3.20	0.83	793
28	22	4.46	3.17	0.71	726	4.31	3.06	0.71	772	4.20	2.98	0.71	793	4.03	2.86	0.71	827
28	24	4.69	2.77	0.59	760	4.52	2.66	0.59	802	4.41	2.60	0.59	827	4.27	2.52	0.59	868
28	26	4.83	2.27	0.47	802	4.69	2.20	0.47	843	4.62	2.17	0.47	868	4.48	2.11	0.47	893
29	18	4.11	4.07	0.99	668	3.94	3.90	0.99	701	3.78	3.74	0.99	735	3.64	3.60	0.99	768
29	20	4.29	3.73	0.87	701	4.11	3.58	0.87	743	3.99	3.47	0.87	760	3.85	3.35	0.87	793
29	22	4.46	3.35	0.75	726	4.31	3.23	0.75	772	4.20	3.15	0.75	793	4.03	3.02	0.75	827
29	24	4.69	2.95	0.63	760	4.52	2.84	0.63	802	4.41	2.78	0.63	827	4.27	2.69	0.63	868
29	26	4.83	2.46	0.51	802	4.69	2.39	0.51	843	4.62	2.36	0.51	868	4.48	2.28	0.51	893
30	18	4.11	4.11	1.00	668	3.94	3.94	1.00	701	3.78	3.78	1.00	735	3.64	3.64	1.00	768
30	20	4.29	3.90	0.91	701	4.11	3.74	0.91	743	3.99	3.63	0.91	760	3.85	3.50	0.91	793
30	22	4.46	3.53	0.79	726	4.31	3.40	0.79	772	4.20	3.32	0.79	793	4.03	3.18	0.79	827
30	24	4.69	3.14	0.67	760	4.52	3.03	0.67	802	4.41	2.95	0.67	827	4.27	2.86	0.67	868
30	26	4.83	2.66	0.55	802	4.69	2.58	0.55	843	4.62	2.54	0.55	868	4.48	2.46	0.55	893
31	18	4.11	4.11	1.00	668	3.94	3.94	1.00	701	3.78	3.78	1.00	735	3.64	3.64	1.00	768
31	20	4.29	4.07	0.95	701	4.11	3.91	0.95	743	3.99	3.79	0.95	760	3.85	3.66	0.95	793
31	22	4.46	3.70	0.83	726	4.31	3.57	0.83	772	4.20	3.49	0.83	793	4.03	3.34	0.83	827
31	24	4.69	3.33	0.71	760	4.52	3.21	0.71	802	4.41	3.13	0.71	827	4.27	3.03	0.71	868
31	26	4.83	2.85	0.59	802	4.69	2.77	0.59	843	4.62	2.73	0.59	868	4.48	2.64	0.59	893
32	18	4.11	4.11	1.00	668	3.94	3.94	1.00	701	3.78	3.78	1.00	735	3.64	3.64	1.00	768
32	20	4.29	4.24	0.99	701	4.11	4.07	0.99	743	3.99	3.95	0.99	760	3.85	3.81	0.99	793
32	22	4.46	3.88	0.87	726	4.31	3.75	0.87	772	4.20	3.65	0.87	793	4.03	3.50	0.87	827
32	24	4.69	3.52	0.75	760	4.52	3.39	0.75	802	4.41	3.31	0.75	827	4.27	3.20	0.75	868
32	26	4.83	3.04	0.63	802	4.69	2.95	0.63	843	4.62	2.91	0.63	868	4.48	2.82	0.63	893

**NOTE** Q : Total capacity (kW) SHF : Sensible heat factor DB : Dry-bulb temperature  
 SHC : Sensible heat capacity (kW) INPUT : Total power input (W) WB : Wet-bulb temperature

**PERFORMANCE DATA COOL operation at Rated frequency**  
**MUZ-FD35VAH**

CAPACITY: 3.5 kW SHF: 0.85 INPUT: 835 W

INDOOR DB (°C)	INDOOR WB (°C)	OUTDOOR DB (°C)											
		35				40				46			
		Q	SHC	SHF	INPUT	Q	SHC	SHF	INPUT	Q	SHC	SHF	INPUT
21	18	3.43	2.30	0.67	818	3.15	2.11	0.67	868	2.91	1.95	0.67	902
21	20	3.61	1.98	0.55	852	3.36	1.85	0.55	893	3.12	1.71	0.55	944
22	18	3.43	2.44	0.71	818	3.15	2.24	0.71	868	2.91	2.06	0.71	902
22	20	3.61	2.13	0.59	852	3.36	1.98	0.59	893	3.12	1.84	0.59	944
22	22	3.82	1.79	0.47	885	3.57	1.68	0.47	935	3.33	1.56	0.47	969
23	18	3.43	2.57	0.75	818	3.15	2.36	0.75	868	2.91	2.18	0.75	902
23	20	3.61	2.27	0.63	852	3.36	2.12	0.63	893	3.12	1.96	0.63	944
23	22	3.82	1.95	0.51	885	3.57	1.82	0.51	935	3.33	1.70	0.51	969
24	18	3.43	2.71	0.79	818	3.15	2.49	0.79	868	2.91	2.29	0.79	902
24	20	3.61	2.42	0.67	852	3.36	2.25	0.67	893	3.12	2.09	0.67	944
24	22	3.82	2.10	0.55	885	3.57	1.96	0.55	935	3.33	1.83	0.55	969
24	24	4.03	1.73	0.43	919	3.78	1.63	0.43	960	3.57	1.54	0.43	1002
25	18	3.43	2.85	0.83	818	3.15	2.61	0.83	868	2.91	2.41	0.83	902
25	20	3.61	2.56	0.71	852	3.36	2.39	0.71	893	3.12	2.21	0.71	944
25	22	3.82	2.25	0.59	885	3.57	2.11	0.59	935	3.33	1.96	0.59	969
25	24	4.03	1.89	0.47	919	3.78	1.78	0.47	960	3.57	1.68	0.47	1002
26	18	3.43	2.98	0.87	818	3.15	2.74	0.87	868	2.91	2.53	0.87	902
26	20	3.61	2.70	0.75	852	3.36	2.52	0.75	893	3.12	2.34	0.75	944
26	22	3.82	2.40	0.63	885	3.57	2.25	0.63	935	3.33	2.09	0.63	969
26	24	4.03	2.05	0.51	919	3.78	1.93	0.51	960	3.57	1.82	0.51	1002
26	26	4.24	1.65	0.39	952	3.99	1.56	0.39	994	3.75	1.46	0.39	1035
27	18	3.43	3.12	0.91	818	3.15	2.87	0.91	868	2.91	2.64	0.91	902
27	20	3.61	2.85	0.79	852	3.36	2.65	0.79	893	3.12	2.46	0.79	944
27	22	3.82	2.56	0.67	885	3.57	2.39	0.67	935	3.33	2.23	0.67	969
27	24	4.03	2.21	0.55	919	3.78	2.08	0.55	960	3.57	1.96	0.55	1002
27	26	4.24	1.82	0.43	952	3.99	1.72	0.43	994	3.75	1.61	0.43	1035
28	18	3.43	3.26	0.95	818	3.15	2.99	0.95	868	2.91	2.76	0.95	902
28	20	3.61	2.99	0.83	852	3.36	2.79	0.83	893	3.12	2.59	0.83	944
28	22	3.82	2.71	0.71	885	3.57	2.53	0.71	935	3.33	2.36	0.71	969
28	24	4.03	2.37	0.59	919	3.78	2.23	0.59	960	3.57	2.11	0.59	1002
28	26	4.24	1.99	0.47	952	3.99	1.88	0.47	994	3.75	1.76	0.47	1035
29	18	3.43	3.40	0.99	818	3.15	3.12	0.99	868	2.91	2.88	0.99	902
29	20	3.61	3.14	0.87	852	3.36	2.92	0.87	893	3.12	2.71	0.87	944
29	22	3.82	2.86	0.75	885	3.57	2.68	0.75	935	3.33	2.49	0.75	969
29	24	4.03	2.54	0.63	919	3.78	2.38	0.63	960	3.57	2.25	0.63	1002
29	26	4.24	2.16	0.51	952	3.99	2.03	0.51	994	3.75	1.91	0.51	1035
30	18	3.43	3.43	1.00	818	3.15	3.15	1.00	868	2.91	2.91	1.00	902
30	20	3.61	3.28	0.91	852	3.36	3.06	0.91	893	3.12	2.83	0.91	944
30	22	3.82	3.01	0.79	885	3.57	2.82	0.79	935	3.33	2.63	0.79	969
30	24	4.03	2.70	0.67	919	3.78	2.53	0.67	960	3.57	2.39	0.67	1002
30	26	4.24	2.33	0.55	952	3.99	2.19	0.55	994	3.75	2.06	0.55	1035
31	18	3.43	3.43	1.00	818	3.15	3.15	1.00	868	2.91	2.91	1.00	902
31	20	3.61	3.42	0.95	852	3.36	3.19	0.95	893	3.12	2.96	0.95	944
31	22	3.82	3.17	0.83	885	3.57	2.96	0.83	935	3.33	2.76	0.83	969
31	24	4.03	2.86	0.71	919	3.78	2.68	0.71	960	3.57	2.53	0.71	1002
31	26	4.24	2.50	0.59	952	3.99	2.35	0.59	994	3.75	2.21	0.59	1035
32	18	3.43	3.43	1.00	818	3.15	3.15	1.00	868	2.91	2.91	1.00	902
32	20	3.61	3.57	0.99	852	3.36	3.33	0.99	893	3.12	3.08	0.99	944
32	22	3.82	3.32	0.87	885	3.57	3.11	0.87	935	3.33	2.89	0.87	969
32	24	4.03	3.02	0.75	919	3.78	2.84	0.75	960	3.57	2.68	0.75	1002
32	26	4.24	2.67	0.63	952	3.99	2.51	0.63	994	3.75	2.36	0.63	1035

**NOTE** Q : Total capacity (kW) SHF : Sensible heat factor DB : Dry-bulb temperature  
 SHC : Sensible heat capacity (kW) INPUT : Total power input (W) WB : Wet-bulb temperature

**PERFORMANCE DATA COOL operation at Rated frequency**

**MUZ-FD50VA**

CAPACITY: 5.0 kW

SHF: 0.77

INPUT: 1500 W

INDOOR DB (°C)	INDOOR WB (°C)	OUTDOOR DB (°C)															
		21				25				27				30			
		Q	SHC	SHF	INPUT	Q	SHC	SHF	INPUT	Q	SHC	SHF	INPUT	Q	SHC	SHF	INPUT
21	18	5.88	3.47	0.59	1200	5.63	3.32	0.59	1260	5.40	3.19	0.59	1320	5.20	3.07	0.59	1380
21	20	6.13	2.88	0.47	1260	5.88	2.76	0.47	1335	5.70	2.68	0.47	1365	5.50	2.59	0.47	1425
22	18	5.88	3.70	0.63	1200	5.63	3.54	0.63	1260	5.40	3.40	0.63	1320	5.20	3.28	0.63	1380
22	20	6.13	3.12	0.51	1260	5.88	3.00	0.51	1335	5.70	2.91	0.51	1365	5.50	2.81	0.51	1425
22	22	6.38	2.49	0.39	1305	6.15	2.40	0.39	1388	6.00	2.34	0.39	1425	5.75	2.24	0.39	1485
23	18	5.88	3.94	0.67	1200	5.63	3.77	0.67	1260	5.40	3.62	0.67	1320	5.20	3.48	0.67	1380
23	20	6.13	3.37	0.55	1260	5.88	3.23	0.55	1335	5.70	3.14	0.55	1365	5.50	3.03	0.55	1425
23	22	6.38	2.74	0.43	1305	6.15	2.64	0.43	1388	6.00	2.58	0.43	1425	5.75	2.47	0.43	1485
24	18	5.88	4.17	0.71	1200	5.63	3.99	0.71	1260	5.40	3.83	0.71	1320	5.20	3.69	0.71	1380
24	20	6.13	3.61	0.59	1260	5.88	3.47	0.59	1335	5.70	3.36	0.59	1365	5.50	3.25	0.59	1425
24	22	6.38	3.00	0.47	1305	6.15	2.89	0.47	1388	6.00	2.82	0.47	1425	5.75	2.70	0.47	1485
24	24	6.70	2.35	0.35	1365	6.45	2.26	0.35	1440	6.30	2.21	0.35	1485	6.10	2.14	0.35	1560
25	18	5.88	4.41	0.75	1200	5.63	4.22	0.75	1260	5.40	4.05	0.75	1320	5.20	3.90	0.75	1380
25	20	6.13	3.86	0.63	1260	5.88	3.70	0.63	1335	5.70	3.59	0.63	1365	5.50	3.47	0.63	1425
25	22	6.38	3.25	0.51	1305	6.15	3.14	0.51	1388	6.00	3.06	0.51	1425	5.75	2.93	0.51	1485
25	24	6.70	2.61	0.39	1365	6.45	2.52	0.39	1440	6.30	2.46	0.39	1485	6.10	2.38	0.39	1560
26	18	5.88	4.64	0.79	1200	5.63	4.44	0.79	1260	5.40	4.27	0.79	1320	5.20	4.11	0.79	1380
26	20	6.13	4.10	0.67	1260	5.88	3.94	0.67	1335	5.70	3.82	0.67	1365	5.50	3.69	0.67	1425
26	22	6.38	3.51	0.55	1305	6.15	3.38	0.55	1388	6.00	3.30	0.55	1425	5.75	3.16	0.55	1485
26	24	6.70	2.88	0.43	1365	6.45	2.77	0.43	1440	6.30	2.71	0.43	1485	6.10	2.62	0.43	1560
26	26	6.90	2.14	0.31	1440	6.70	2.08	0.31	1515	6.60	2.05	0.31	1560	6.40	1.98	0.31	1605
27	18	5.88	4.88	0.83	1200	5.63	4.67	0.83	1260	5.40	4.48	0.83	1320	5.20	4.32	0.83	1380
27	20	6.13	4.35	0.71	1260	5.88	4.17	0.71	1335	5.70	4.05	0.71	1365	5.50	3.91	0.71	1425
27	22	6.38	3.76	0.59	1305	6.15	3.63	0.59	1388	6.00	3.54	0.59	1425	5.75	3.39	0.59	1485
27	24	6.70	3.15	0.47	1365	6.45	3.03	0.47	1440	6.30	2.96	0.47	1485	6.10	2.87	0.47	1560
27	26	6.90	2.42	0.35	1440	6.70	2.35	0.35	1515	6.60	2.31	0.35	1560	6.40	2.24	0.35	1605
28	18	5.88	5.11	0.87	1200	5.63	4.89	0.87	1260	5.40	4.70	0.87	1320	5.20	4.52	0.87	1380
28	20	6.13	4.59	0.75	1260	5.88	4.41	0.75	1335	5.70	4.28	0.75	1365	5.50	4.13	0.75	1425
28	22	6.38	4.02	0.63	1305	6.15	3.87	0.63	1388	6.00	3.78	0.63	1425	5.75	3.62	0.63	1485
28	24	6.70	3.42	0.51	1365	6.45	3.29	0.51	1440	6.30	3.21	0.51	1485	6.10	3.11	0.51	1560
28	26	6.90	2.69	0.39	1440	6.70	2.61	0.39	1515	6.60	2.57	0.39	1560	6.40	2.50	0.39	1605
29	18	5.88	5.35	0.91	1200	5.63	5.12	0.91	1260	5.40	4.91	0.91	1320	5.20	4.73	0.91	1380
29	20	6.13	4.84	0.79	1260	5.88	4.64	0.79	1335	5.70	4.50	0.79	1365	5.50	4.35	0.79	1425
29	22	6.38	4.27	0.67	1305	6.15	4.12	0.67	1388	6.00	4.02	0.67	1425	5.75	3.85	0.67	1485
29	24	6.70	3.69	0.55	1365	6.45	3.55	0.55	1440	6.30	3.47	0.55	1485	6.10	3.36	0.55	1560
29	26	6.90	2.97	0.43	1440	6.70	2.88	0.43	1515	6.60	2.84	0.43	1560	6.40	2.75	0.43	1605
30	18	5.88	5.58	0.95	1200	5.63	5.34	0.95	1260	5.40	5.13	0.95	1320	5.20	4.94	0.95	1380
30	20	6.13	5.08	0.83	1260	5.88	4.88	0.83	1335	5.70	4.73	0.83	1365	5.50	4.57	0.83	1425
30	22	6.38	4.53	0.71	1305	6.15	4.37	0.71	1388	6.00	4.26	0.71	1425	5.75	4.08	0.71	1485
30	24	6.70	3.95	0.59	1365	6.45	3.81	0.59	1440	6.30	3.72	0.59	1485	6.10	3.60	0.59	1560
30	26	6.90	3.24	0.47	1440	6.70	3.15	0.47	1515	6.60	3.10	0.47	1560	6.40	3.01	0.47	1605
31	18	5.88	5.82	0.99	1200	5.63	5.57	0.99	1260	5.40	5.35	0.99	1320	5.20	5.15	0.99	1380
31	20	6.13	5.33	0.87	1260	5.88	5.11	0.87	1335	5.70	4.96	0.87	1365	5.50	4.79	0.87	1425
31	22	6.38	4.78	0.75	1305	6.15	4.61	0.75	1388	6.00	4.50	0.75	1425	5.75	4.31	0.75	1485
31	24	6.70	4.22	0.63	1365	6.45	4.06	0.63	1440	6.30	3.97	0.63	1485	6.10	3.84	0.63	1560
31	26	6.90	3.52	0.51	1440	6.70	3.42	0.51	1515	6.60	3.37	0.51	1560	6.40	3.26	0.51	1605
32	18	5.88	5.88	1.00	1200	5.63	5.63	1.00	1260	5.40	5.40	1.00	1320	5.20	5.20	1.00	1380
32	20	6.13	5.57	0.91	1260	5.88	5.35	0.91	1335	5.70	5.19	0.91	1365	5.50	5.01	0.91	1425
32	22	6.38	5.04	0.79	1305	6.15	4.86	0.79	1388	6.00	4.74	0.79	1425	5.75	4.54	0.79	1485
32	24	6.70	4.49	0.67	1365	6.45	4.32	0.67	1440	6.30	4.22	0.67	1485	6.10	4.09	0.67	1560
32	26	6.90	3.80	0.55	1440	6.70	3.69	0.55	1515	6.60	3.63	0.55	1560	6.40	3.52	0.55	1605

**NOTE** Q : Total capacity (kW) SHF : Sensible heat factor DB : Dry-bulb temperature  
 SHC : Sensible heat capacity (kW) INPUT : Total power input (W) WB : Wet-bulb temperature

**PERFORMANCE DATA COOL operation at Rated frequency**  
**MUZ-FD50VA**

CAPACITY: 5.0 kW SHF: 0.77 INPUT: 1500 W

INDOOR DB (°C)	INDOOR WB (°C)	OUTDOOR DB (°C)											
		35				40				46			
		Q	SHC	SHF	INPUT	Q	SHC	SHF	INPUT	Q	SHC	SHF	INPUT
21	18	4.90	2.89	0.59	1470	4.50	2.66	0.59	1560	4.15	2.45	0.59	1620
21	20	5.15	2.42	0.47	1530	4.80	2.26	0.47	1605	4.45	2.09	0.47	1695
22	18	4.90	3.09	0.63	1470	4.50	2.84	0.63	1560	4.15	2.61	0.63	1620
22	20	5.15	2.63	0.51	1530	4.80	2.45	0.51	1605	4.45	2.27	0.51	1695
22	22	5.45	2.13	0.39	1590	5.10	1.99	0.39	1680	4.75	1.85	0.39	1740
23	18	4.90	3.28	0.67	1470	4.50	3.02	0.67	1560	4.15	2.78	0.67	1620
23	20	5.15	2.83	0.55	1530	4.80	2.64	0.55	1605	4.45	2.45	0.55	1695
23	22	5.45	2.34	0.43	1590	5.10	2.19	0.43	1680	4.75	2.04	0.43	1740
24	18	4.90	3.48	0.71	1470	4.50	3.20	0.71	1560	4.15	2.95	0.71	1620
24	20	5.15	3.04	0.59	1530	4.80	2.83	0.59	1605	4.45	2.63	0.59	1695
24	22	5.45	2.56	0.47	1590	5.10	2.40	0.47	1680	4.75	2.23	0.47	1740
24	24	5.75	2.01	0.35	1650	5.40	1.89	0.35	1725	5.10	1.79	0.35	1800
25	18	4.90	3.68	0.75	1470	4.50	3.38	0.75	1560	4.15	3.11	0.75	1620
25	20	5.15	3.24	0.63	1530	4.80	3.02	0.63	1605	4.45	2.80	0.63	1695
25	22	5.45	2.78	0.51	1590	5.10	2.60	0.51	1680	4.75	2.42	0.51	1740
25	24	5.75	2.24	0.39	1650	5.40	2.11	0.39	1725	5.10	1.99	0.39	1800
26	18	4.90	3.87	0.79	1470	4.50	3.56	0.79	1560	4.15	3.28	0.79	1620
26	20	5.15	3.45	0.67	1530	4.80	3.22	0.67	1605	4.45	2.98	0.67	1695
26	22	5.45	3.00	0.55	1590	5.10	2.81	0.55	1680	4.75	2.61	0.55	1740
26	24	5.75	2.47	0.43	1650	5.40	2.32	0.43	1725	5.10	2.19	0.43	1800
26	26	6.05	1.88	0.31	1710	5.70	1.77	0.31	1785	5.35	1.66	0.31	1860
27	18	4.90	4.07	0.83	1470	4.50	3.74	0.83	1560	4.15	3.44	0.83	1620
27	20	5.15	3.66	0.71	1530	4.80	3.41	0.71	1605	4.45	3.16	0.71	1695
27	22	5.45	3.22	0.59	1590	5.10	3.01	0.59	1680	4.75	2.80	0.59	1740
27	24	5.75	2.70	0.47	1650	5.40	2.54	0.47	1725	5.10	2.40	0.47	1800
27	26	6.05	2.12	0.35	1710	5.70	2.00	0.35	1785	5.35	1.87	0.35	1860
28	18	4.90	4.26	0.87	1470	4.50	3.92	0.87	1560	4.15	3.61	0.87	1620
28	20	5.15	3.86	0.75	1530	4.80	3.60	0.75	1605	4.45	3.34	0.75	1695
28	22	5.45	3.43	0.63	1590	5.10	3.21	0.63	1680	4.75	2.99	0.63	1740
28	24	5.75	2.93	0.51	1650	5.40	2.75	0.51	1725	5.10	2.60	0.51	1800
28	26	6.05	2.36	0.39	1710	5.70	2.22	0.39	1785	5.35	2.09	0.39	1860
29	18	4.90	4.46	0.91	1470	4.50	4.10	0.91	1560	4.15	3.78	0.91	1620
29	20	5.15	4.07	0.79	1530	4.80	3.79	0.79	1605	4.45	3.52	0.79	1695
29	22	5.45	3.65	0.67	1590	5.10	3.42	0.67	1680	4.75	3.18	0.67	1740
29	24	5.75	3.16	0.55	1650	5.40	2.97	0.55	1725	5.10	2.81	0.55	1800
29	26	6.05	2.60	0.43	1710	5.70	2.45	0.43	1785	5.35	2.30	0.43	1860
30	18	4.90	4.66	0.95	1470	4.50	4.28	0.95	1560	4.15	3.94	0.95	1620
30	20	5.15	4.27	0.83	1530	4.80	3.98	0.83	1605	4.45	3.69	0.83	1695
30	22	5.45	3.87	0.71	1590	5.10	3.62	0.71	1680	4.75	3.37	0.71	1740
30	24	5.75	3.39	0.59	1650	5.40	3.19	0.59	1725	5.10	3.01	0.59	1800
30	26	6.05	2.84	0.47	1710	5.70	2.68	0.47	1785	5.35	2.51	0.47	1860
31	18	4.90	4.85	0.99	1470	4.50	4.46	0.99	1560	4.15	4.11	0.99	1620
31	20	5.15	4.48	0.87	1530	4.80	4.18	0.87	1605	4.45	3.87	0.87	1695
31	22	5.45	4.09	0.75	1590	5.10	3.83	0.75	1680	4.75	3.56	0.75	1740
31	24	5.75	3.62	0.63	1650	5.40	3.40	0.63	1725	5.10	3.21	0.63	1800
31	26	6.05	3.09	0.51	1710	5.70	2.91	0.51	1785	5.35	2.73	0.51	1860
32	18	4.90	4.90	1.00	1470	4.50	4.50	1.00	1560	4.15	4.15	1.00	1620
32	20	5.15	4.69	0.91	1530	4.80	4.37	0.91	1605	4.45	4.05	0.91	1695
32	22	5.45	4.31	0.79	1590	5.10	4.03	0.79	1680	4.75	3.75	0.79	1740
32	24	5.75	3.85	0.67	1650	5.40	3.62	0.67	1725	5.10	3.42	0.67	1800
32	26	6.05	3.33	0.55	1710	5.70	3.14	0.55	1785	5.35	2.94	0.55	1860

**NOTE** Q : Total capacity (kW) SHF : Sensible heat factor DB : Dry-bulb temperature  
 SHC : Sensible heat capacity (kW) INPUT : Total power input (W) WB : Wet-bulb temperature

**PERFORMANCE DATA HEAT operation at Rated frequency**  
**MUZ-FD25VA MUZ-FD25VAH**

CAPACITY: 3.2 kW INPUT: 610 W

INDOOR DB (°C)	OUTDOOR WB (°C)													
	-10		-5		0		5		10		15		20	
	Q	INPUT	Q	INPUT	Q	INPUT	Q	INPUT	Q	INPUT	Q	INPUT	Q	INPUT
15	2.02	397	2.43	476	2.85	537	3.26	580	3.68	616	4.06	634	4.48	647
21	1.92	427	2.30	506	2.72	561	3.10	604	3.52	634	3.90	653	4.30	677
26	1.73	458	2.14	537	2.53	592	2.94	634	3.36	665	3.74	683	4.16	702

**MUZ-FD35VA**

CAPACITY: 4.0 kW INPUT: 865 W

INDOOR DB (°C)	OUTDOOR WB (°C)													
	-10		-5		0		5		10		15		20	
	Q	INPUT	Q	INPUT	Q	INPUT	Q	INPUT	Q	INPUT	Q	INPUT	Q	INPUT
15	2.52	562	3.04	675	3.56	761	4.08	822	4.60	874	5.08	900	5.60	917
21	2.40	606	2.88	718	3.40	796	3.88	856	4.40	900	4.88	926	5.38	960
26	2.16	649	2.68	761	3.16	839	3.68	900	4.20	943	4.68	969	5.20	995

**MUZ-FD35VAH**

CAPACITY: 4.0 kW INPUT: 850 W

INDOOR DB (°C)	OUTDOOR WB (°C)													
	-10		-5		0		5		10		15		20	
	Q	INPUT	Q	INPUT	Q	INPUT	Q	INPUT	Q	INPUT	Q	INPUT	Q	INPUT
15	2.52	553	3.04	663	3.56	748	4.08	808	4.60	859	5.08	884	5.60	901
21	2.40	595	2.88	706	3.40	782	3.88	842	4.40	884	4.88	910	5.38	944
26	2.16	638	2.68	748	3.16	825	3.68	884	4.20	927	4.68	952	5.20	978

**MUZ-FD50VA**

CAPACITY: 5.8 kW INPUT: 1550 W

INDOOR DB (°C)	OUTDOOR WB (°C)													
	-10		-5		0		5		10		15		20	
	Q	INPUT	Q	INPUT	Q	INPUT	Q	INPUT	Q	INPUT	Q	INPUT	Q	INPUT
15	3.65	1008	4.41	1209	5.16	1364	5.92	1473	6.67	1566	7.37	1612	8.12	1643
21	3.48	1085	4.18	1287	4.93	1426	5.63	1535	6.38	1612	7.08	1659	7.80	1721
26	3.13	1163	3.89	1364	4.58	1504	5.34	1612	6.09	1690	6.79	1736	7.54	1783

**NOTE** Q: Total capacity (kW) INPUT : Total power input (W) DB: Dry-bulb temperature WB: Wet-bulb temperature

**MUZ-FD25VA MUZ-FD25VAH MUZ-FD35VA MUZ-FD35VAH MUZ-FD50VA**

**9-1. OUTDOOR FAN MOTOR CONTROL**

The fan motor turns ON/OFF, interlocking with the compressor.

[ON] The fan motor turns ON 5 seconds before the compressor starts up.

[OFF] The fan motor turns OFF 15 seconds after the compressor has stopped running.

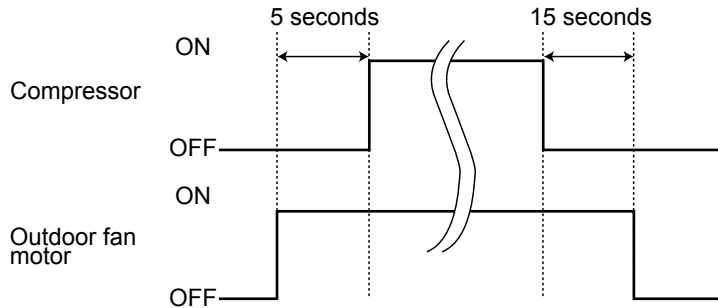

**9-2. R.V. COIL CONTROL**

Heating . . . . . ON

Cooling . . . . . OFF

Dry . . . . . OFF

**NOTE:** The 4-way valve reverses for 5 seconds right before start-up of the compressor.

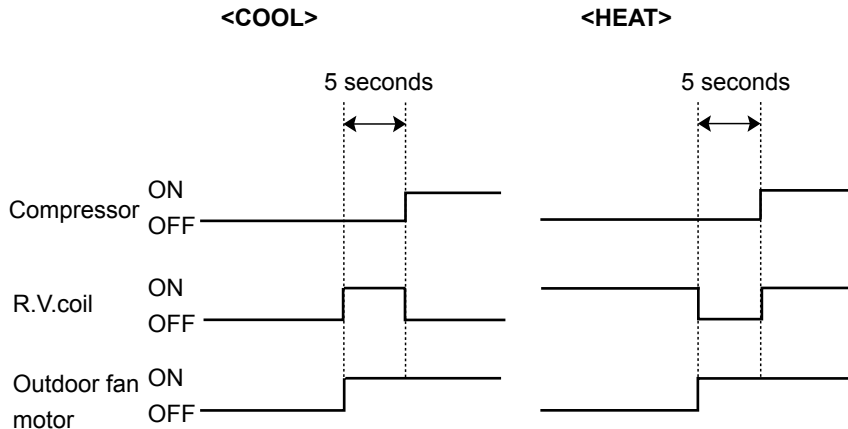

**9-3. RELATION BETWEEN MAIN SENSOR AND ACTUATOR**

**MUZ-FD25/35**

Sensor	Purpose	Actuator					
		Compressor	LEV	Outdoor fan motor	R.V.coil	Indoor fan motor	Defrost heater
Discharge temperature thermistor	Protection	○	○				
Indoor coil temperature thermistor	Cooling: Coil frost prevention	○					
	Heating: High pressure protection	○	○	○			
Defrost thermistor	Cooling: High pressure protection	○	○	○			
	Heating: Defrosting	○	○	○	○	○	
Fin temperature thermistor	Protection	○		○			
Ambient temperature thermistor	Cooling: Low ambient temperature operation	○	○	○			
	Heating: Defrosting (Heater)						○
Outdoor heat exchanger temperature thermistor	Low outside temperature operation	○	○	○			

## MUZ-FD50

Sensor	Purpose	Actuator				
		Compressor	LEV	Outdoor fan motor	R.V.coil	Indoor fan motor
Discharge temperature thermistor	Protection	○	○			
Indoor coil temperature thermistor	Cooling: Coil frost prevention	○				
	Heating: High pressure protection	○	○			
Defrost thermistor	Heating: Defrosting	○	○	○	○	○
Fin temperature thermistor	Protection	○		○		
Ambient temperature thermistor	Cooling: Low ambient temperature operation	○		○		
Outdoor heat exchanger temperature thermistor	Cooling: Low ambient temperature operation	○		○		
	Cooling: High pressure protection	○	○			

# 10 SERVICE FUNCTIONS

## MUZ-FD25VA MUZ-FD25VAH MUZ-FD35VA MUZ-FD35VAH MUZ-FD50VA

### 10-1. CHANGE IN DEFROST SETTING

#### Changing defrost finish temperature

#### MUZ-FD25/35

<JS> To change the defrost finish temperature, cut/solder the JS wire of the outdoor inverter P.C. board. (Refer to 11-6-1.)

Jumper wire		Defrost finish temperature (°C)
JS	Soldered (Initial setting)	5
	None (Cut)	10

#### MUZ-FD50

1. Turn OFF the power supply for the air conditioner before making the setting.
2. Set the 4th Dip Switch of SW1 on the outdoor electronic control P.C. board to ON to change the defrost finish temperature. (Refer to 11-6-2.)

4th Dip Switch of SW1	Defrost finish temperature (°C)
OFF (Initial setting)	8.3
ON	12.2

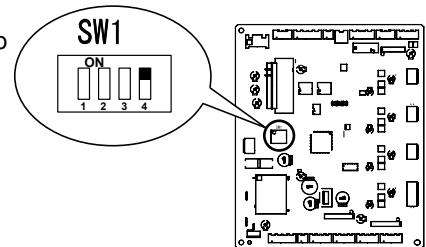

### 10-2. PRE-HEAT CONTROL SETTING

#### PRE-HEAT CONTROL

When moisture gets into the refrigerant cycle, it may interfere the start-up of the compressor at low outside temperature. The pre-heat control prevents this interference. The pre-heat control turns ON when outside temperature is 20°C or below. When pre-heat control is turned ON, compressor is energized. (About 50 W)

#### MUZ-FD25/35

<JK> To activate the pre-heat control, cut the JK wire of the inverter P.C. board. (Refer to 11-6.1)

**NOTE:** When the inverter P.C. board is replaced, check the Jumper wires, and cut/solder them if necessary.

#### MUZ-FD50

#### [How to activate pre-heat control]

1. Turn OFF the power supply for the air conditioner before making the setting.
2. Set the 2nd Dip Switch of SW1 on the outdoor electronic control P.C. board to ON to activate pre-heat control function. (Refer to 11-6-2.)

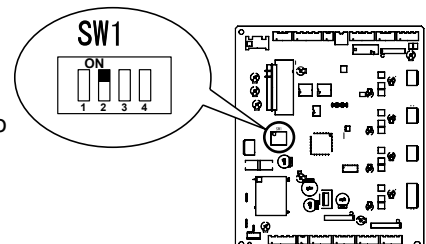

## MUZ-FD25VA MUZ-FD25VAH MUZ-FD35VA MUZ-FD35VAH MUZ-FD50VA

### 11-1. CAUTIONS ON TROUBLESHOOTING

#### 1. Before troubleshooting, check the following

- 1) Check the power supply voltage.
- 2) Check the indoor/outdoor connecting wire for miswiring.

#### 2. Take care of the following during servicing

- 1) Before servicing the air conditioner, be sure to turn OFF the main unit first with the remote controller, and after confirming the horizontal vane is closed, turn OFF the breaker and/or disconnect the power plug.
- 2) Be sure to turn OFF the power supply before removing the front panel, the cabinet, the top panel, and the electronic control P.C. board.
- 3) When removing the electrical parts, be careful of the residual voltage of smoothing capacitor.
- 4) When removing the electronic control P.C. board, hold the edge of the board with care NOT to apply stress on the components.
- 5) When connecting or disconnecting the connectors, hold the housing of the connector. DO NOT pull the lead wires.

#### Incorrect

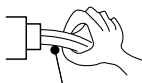

Lead wiring

#### Correct

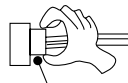

Housing point

#### 3. Troubleshooting procedure

- 1) First, check if the OPERATION INDICATOR lamp on the indoor unit is flashing on and off to indicate an abnormality. To make sure, check how many times the OPERATION INDICATOR lamp is flashing on and off before starting service work.
- 2) Before servicing, check that the connector and terminal are connected properly.
- 3) When the electronic control P.C. board seems to be defective, check the copper foil pattern for disconnection and the components for bursting and discoloration.
- 4) Refer to 11-2 and 11-3.

## 11-2. FAILURE MODE RECALL FUNCTION

Outline of the function

This air conditioner can memorize the abnormal condition which has occurred once.

Even though LED indication listed on the troubleshooting check table (11-3.) disappears, the memorized failure details can be recalled.

This mode is very useful when the unit needs to be repaired for the abnormality which does not recur.

### 1. Flow chart of failure mode recall function for the indoor/outdoor unit

Operational procedure

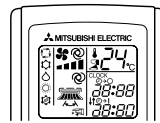
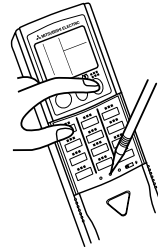
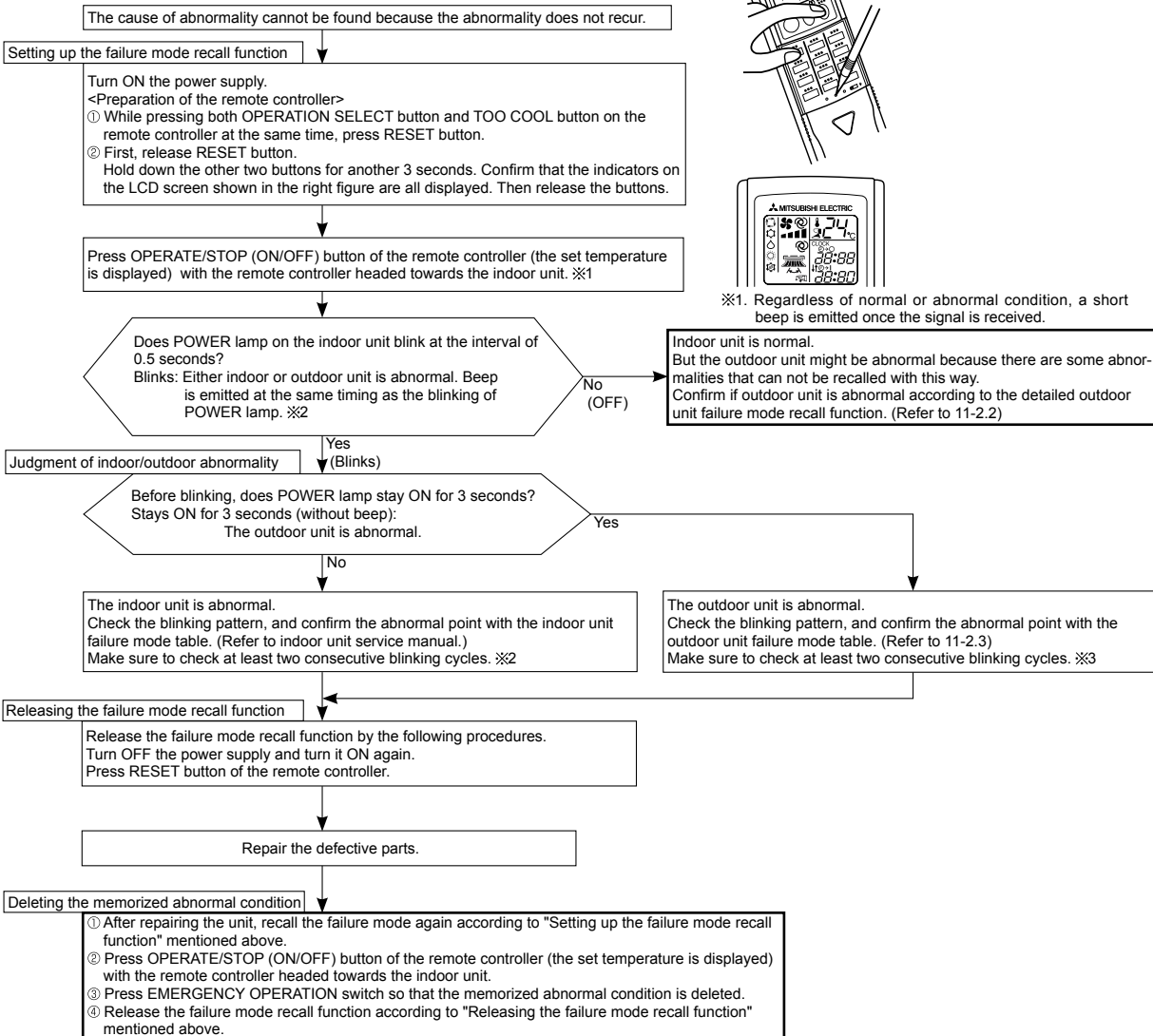

※1. Regardless of normal or abnormal condition, a short beep is emitted once the signal is received.

**NOTE:** 1. Make sure to release the failure mode recall function once it is set up, otherwise the unit cannot operate properly.  
2. If the abnormal condition is not deleted from the memory, the last abnormal condition is kept memorized.

※2. Blinking pattern when the indoor unit is abnormal:

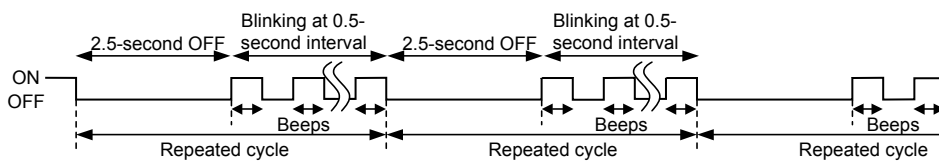

※3. Blinking pattern when the outdoor unit is abnormal:

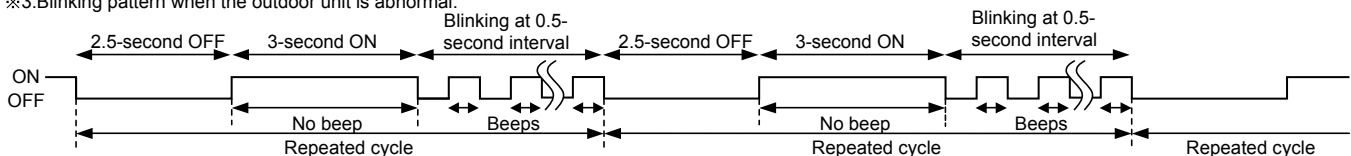

## 2. Flow chart of the detailed outdoor unit failure mode recall function

### Operational procedure

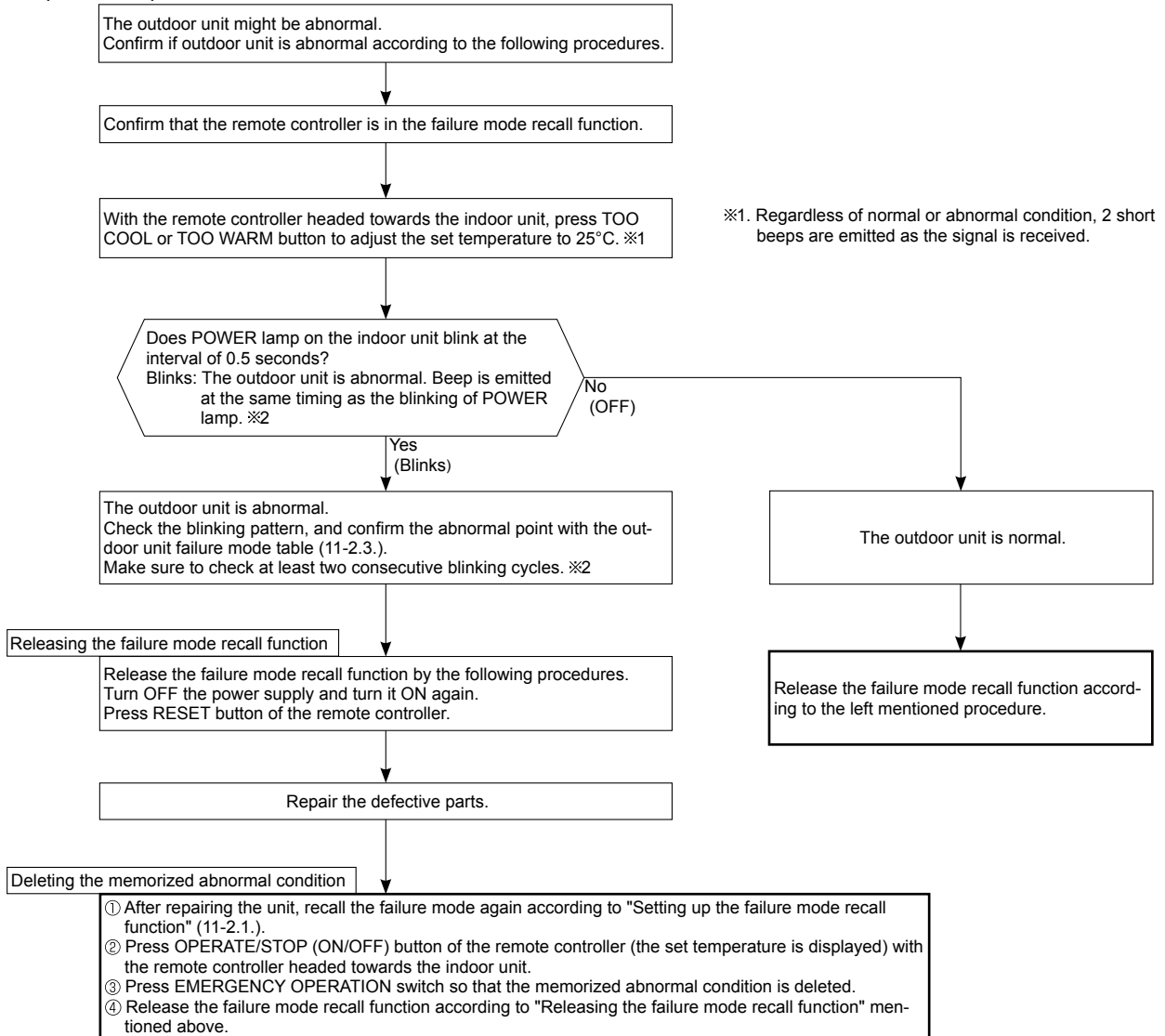

**NOTE:** 1. Make sure to release the failure mode recall function once it is set up, otherwise the unit cannot operate properly.  
2. If the abnormal condition is not deleted from the memory, the last abnormal condition is kept memorized.

※2. Blinking pattern when outdoor unit is abnormal:

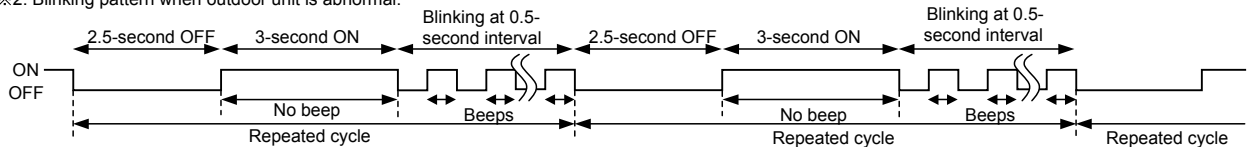

### 3. Outdoor unit failure mode table MUZ-FD25/35

POWER lamp (Indoor unit)	Abnormal point (Failure mode / protection)	LED indication (Outdoor P.C. board)	Condition	Remedy	Indoor/outdoor unit failure mode recall function	Outdoor unit failure mode recall function
OFF	None (Normal)	—	—	—	—	—
2-time flash 2.5 seconds OFF	Outdoor power system	—	Overcurrent protection stop is continuously performed 3 times within 1 minute after the compressor gets started.	<ul style="list-style-type: none"> <li>•Reconnect connectors.</li> <li>•Refer to 11-5. Ⓐ"How to check inverter/compressor".</li> <li>•Check stop valve.</li> </ul>	○	○
3-time flash 2.5 seconds OFF	Discharge temperature thermistor	1-time flash every 2.5 seconds	Thermistor shorts or opens during compressor running.	<ul style="list-style-type: none"> <li>•Refer to 11-5. Ⓒ "Check of outdoor thermistors". Defective outdoor thermistors can be identified by checking the blinking pattern of LED.</li> </ul>	○	○
	Defrost thermistor					
	Fin temperature thermistor	3-time flash 2.5 seconds OFF				
	P.C. board temperature thermistor	4-time flash 2.5 seconds OFF				
	Ambient temperature thermistor	2-time flash 2.5 seconds OFF				
4-time flash 2.5 seconds OFF	Overcurrent	11-time flash 2.5 seconds OFF	Large current flows into intelligent power module.	<ul style="list-style-type: none"> <li>•Reconnect compressor connector.</li> <li>•Refer to 11-5. Ⓐ"How to check inverter/compressor".</li> <li>•Check stop valve.</li> </ul>	—	○
	Compressor synchronous abnormality (Compressor start-up failure protection)	12-time flash 2.5 seconds OFF	Waveform of compressor current is distorted.	<ul style="list-style-type: none"> <li>•Reconnect compressor connector.</li> <li>•Refer to 11-5. Ⓐ"How to check inverter/compressor".</li> </ul>	—	○
5-time flash 2.5 seconds OFF	Discharge temperature	—	Temperature of discharge temperature thermistor exceeds 116°C, compressor stops. Compressor can restart if discharge temperature thermistor reads 100°C or less 3 minutes later.	<ul style="list-style-type: none"> <li>•Check refrigerant circuit and refrigerant amount.</li> <li>•Refer to 11-5. Ⓒ"Check of LEV".</li> </ul>	—	○
6-time flash 2.5 seconds OFF	High pressure	—	Temperature indoor coil thermistor exceeds 70°C in HEAT mode. Temperature defrost thermistor exceeds 70°C in COOL mode.	<ul style="list-style-type: none"> <li>•Check refrigerant circuit and refrigerant amount.</li> <li>•Check stop valve.</li> </ul>	—	○
7-time flash 2.5 seconds OFF	Fin temperature/ P.C. board temperature	7-time flash 2.5 seconds OFF	Temperature of fin temperature thermistor on the inverter P.C. board exceeds 75 ~ 80°C, or temperature of P.C. board temperature thermistor on the inverter P.C. board exceeds 70 ~ 75°C.	<ul style="list-style-type: none"> <li>•Check around outdoor unit.</li> <li>•Check outdoor unit air passage.</li> <li>•Refer to 11-5. ①"Check of outdoor fan motor".</li> </ul>	—	○
8-time flash 2.5 seconds OFF	Outdoor fan motor	—	Outdoor fan has stopped 3 times in a row within 30 seconds after outdoor fan start-up.	<ul style="list-style-type: none"> <li>•Refer to 11-5. ①"Check of outdoor fan motor".</li> <li>•Refer to 11-5. ②"Check of inverter P.C. board".</li> </ul>	—	○
9-time flash 2.5 seconds OFF	Nonvolatile memory data	5-time flash 2.5 seconds OFF	Nonvolatile memory data cannot be read properly.	<ul style="list-style-type: none"> <li>•Replace the inverter P.C. board.</li> </ul>	○	○
10-time flash 2.5 seconds OFF	Discharge temperature	—	Temperature of discharge temperature thermistor has been 50°C or less for 20 minutes.	<ul style="list-style-type: none"> <li>•Refer to 11-5. Ⓒ"Check of LEV".</li> <li>•Check refrigerant circuit and refrigerant amount.</li> </ul>	—	○
11-time flash 2.5 seconds OFF	DC voltage	8-time flash 2.5 seconds OFF	DC voltage of inverter cannot be detected normally.	<ul style="list-style-type: none"> <li>•Refer to 11-5. Ⓐ"How to check inverter/compressor".</li> </ul>	—	○
	Each phase current of compressor	9-time flash 2.5 seconds OFF	Each phase current of compressor cannot be detected normally.			
12-time flash 2.5 seconds OFF	Overcurrent Compressor open-phase	10-time flash 2.5 seconds OFF	Large current flows into intelligent power module (IPM). The open-phase operation of compressor is detected. The interphase short out occurs in the output of the intelligent power module (IPM). The compressor winding shorts out.	<ul style="list-style-type: none"> <li>•Reconnect compressor connector.</li> <li>•Refer to 11-5. Ⓐ"How to check inverter/compressor".</li> </ul>	—	○
14-time flash 2.5 seconds OFF	Stop valve (Closed valve)	14-time flash 2.5 seconds OFF	Closed valve is detected by compressor current.	<ul style="list-style-type: none"> <li>•Check stop valve</li> </ul>	○	○

**NOTE:** Blinking patterns of this mode differ from the ones of Troubleshooting check table (11-3.).

## MUZ-FD50VA

POWER lamp (Indoor unit)	Abnormal point (Failure mode / protection)	LED indication (Outdoor P.C. board)		Condition	Remedy	Indoor/outdoor unit failure mode recall function
		LED1	LED2			
OFF	None (Normal)	Lighting	Lighting	—	—	—
2-time flash	Outdoor power system	Lighting	Lighting	Overcurrent protection stop is continuously performed 3 times within 1 minute after the compressor gets started, or when converter protection stop or bus-bar voltage protection stop is continuously performed 3 times within 3 minutes after start-up.	<ul style="list-style-type: none"> <li>• Check the connection of the compressor connecting wire.</li> <li>• Refer to 11-5.④ "How to check inverter/compressor".</li> <li>• Check the stop valve.</li> </ul>	○
3-time flash	Discharge temperature thermistor	Lighting	Once	Thermistor shorts or opens during compressor running.	<ul style="list-style-type: none"> <li>• Refer to 11-5.⑥ "Check of outdoor thermistors".</li> </ul>	○
	Defrost thermistor	Lighting	Once			
	Ambient temperature thermistor	Lighting	Twice			
	Fin temperature thermistor	Lighting	3 times			
	P.C. board temperature thermistor	Lighting	4 times			
Outdoor heat exchanger temperature thermistor	Lighting	9 times	<ul style="list-style-type: none"> <li>• Replace the outdoor electronic control P.C. board.</li> <li>• Refer to 11-5.⑥ "Check of outdoor thermistors".</li> </ul>			
4-time flash	Overcurrent	Once	Goes out	28 A current flows into intelligent power module.	<ul style="list-style-type: none"> <li>• Reconnect compressor connector.</li> <li>• Refer to 11-5.④ "How to check inverter/compressor.</li> <li>• Check the stop valve.</li> </ul>	—
5-time flash	Discharge temperature	Lighting	Lighting	Discharge temperature exceeds 116°C during operation. Compressor can restart if discharge temperature thermistor reads 100°C or less 3 minutes later.	<ul style="list-style-type: none"> <li>• Check refrigerant circuit and refrigerant amount.</li> <li>• Refer to 11-5.⑧ "Check of LEV".</li> </ul>	—
6-time flash	High pressure	Lighting	Lighting	The outdoor heat exchanger temperature exceeds 70°C during cooling or the indoor gas pipe temperature exceeds 70°C during heating.	<ul style="list-style-type: none"> <li>• Check refrigerant circuit and refrigerant amount.</li> <li>• Check the stop valve.</li> </ul>	—
7-time flash	Fin temperature	3 times	Goes out	The fin temperature exceeds 87°C during operation.	<ul style="list-style-type: none"> <li>• Check around outdoor unit.</li> <li>• Check outdoor unit air passage.</li> <li>• Refer to 11-5.① "Check of outdoor fan motor".</li> </ul>	—
	P.C. board temperature	4 times	Goes out	The P.C. board temperature exceeds 70°C during operation.		
8-time flash	Outdoor fan motor	Lighting	Lighting	Failure occurs continuously three times within 30 seconds after the fan gets started.	<ul style="list-style-type: none"> <li>• Refer to 11-5.① "Check of outdoor fan motor".</li> </ul>	—
9-time flash	Nonvolatile memory data	Lighting	5 times	Nonvolatile memory data cannot be read properly.	<ul style="list-style-type: none"> <li>• Replace the outdoor electronic control P.C. board.</li> </ul>	○
10-time flash	Discharge temperature	Lighting	Lighting	The frequency of the compressor is kept 80 Hz or more and the discharge temperature is kept under 39°C for more than 20 minutes.	<ul style="list-style-type: none"> <li>• Check refrigerant circuit and refrigerant amount.</li> <li>• Refer to 11-5.⑧ "Check of LEV".</li> </ul>	—
11-time flash	Communication error between P.C. boards	Lighting	6 times	Communication error occurs between the electronic control P.C. board and power board for more than 10 seconds.	<ul style="list-style-type: none"> <li>• Check the connecting wire between outdoor electronic control P.C. board and power board.</li> </ul>	—
				The communication between boards protection stop is continuously performed twice.		
	Current sensor	Lighting	7 times	A short or open circuit is detected in the current sensor during compressor operating.	<ul style="list-style-type: none"> <li>• Replace the power board.</li> </ul>	—
				Current sensor protection stop is continuously performed twice.		
	Zero cross detecting circuit	5 times	Goes out	Zero cross signal cannot be detected while the compressor is operating.	<ul style="list-style-type: none"> <li>• Check the connecting wire among electronic control P.C. board, noise filter P.C. board and power board.</li> </ul>	—
The protection stop of the zero cross detecting circuit is continuously performed 10 times.						
Converter	5 times	Goes out	A failure is detected in the operation of the converter during operation.	<ul style="list-style-type: none"> <li>• Check the voltage of power supply.</li> <li>• Replace the power board.</li> </ul>	—	
Bus-bar voltage (1)	5 times	Goes out	The bus-bar voltage exceeds 400 V or falls to 200 V or below during compressor operating.	<ul style="list-style-type: none"> <li>• Check the voltage of power supply.</li> <li>• Replace the outdoor electronic control P.C. board.</li> </ul>	—	
Bus-bar voltage (2) ※ Even if this protection stop is performed continuously 3 times, it does not mean the abnormality in outdoor power system.	6 times	Goes out	The bus-bar voltage exceeds 400 V or falls to 50 V or below during compressor operating.			

**NOTE:** Blinking patterns of this mode differ from the ones of Troubleshooting check table (11-3.).

### 11-3. TROUBLESHOOTING CHECK TABLE MUZ-FD25/35

No.	Symptom	LED indication	Abnormal point/ Condition	Condition	Remedy	
1	Outdoor unit does not operate.	1-time flash every 2.5 seconds	Outdoor power system	Overcurrent protection stop is continuously performed 3 times within 1 minute after the compressor gets started.	•Reconnect connector of compressor. •Refer to 11-5.Ⓐ "How to check inverter/compressor". •Check stop valve.	
2			Outdoor thermistors	Discharge temperature thermistor, fin temperature thermistor, defrost thermistor, P.C. board temperature thermistor or ambient temperature thermistor shorts or opens during compressor running.	•Refer to 11-5.Ⓒ "Check of outdoor thermistors".	
3			Outdoor control system	Nonvolatile memory data cannot be read properly. (POWER lamp of the indoor unit lights up or flashes 7-time.)	•Replace inverter P.C. board.	
4		6-time flash 2.5 seconds OFF	Serial signal	The communication fails between the indoor and outdoor unit for 3 minutes.	•Refer to 11-5.Ⓓ "How to check miswiring and serial signal error".	
5		11-time flash 2.5 seconds OFF	Stop valve/ Closed valve	Closed valve is detected by compressor current.	•Check stop valve.	
6		14-time flash 2.5 seconds OFF	Outdoor unit (Other abnormality)	Outdoor unit is defective.	•Refer to 11-2.2. "Flow chart of the detailed outdoor unit failure mode recall function".	
7	'Outdoor unit stops and restarts 3 minutes later' is repeated.	2-time flash 2.5 seconds OFF	Overcurrent protection	Large current flows into intelligent power module.	•Reconnect connector of compressor. •Refer to 11-5.Ⓐ "How to check inverter/compressor". •Check stop valve.	
8		3-time flash 2.5 seconds OFF	Discharge temperature overheat protection	Temperature of discharge temperature thermistor exceeds 116°C, compressor stops. Compressor can restart if discharge temperature thermistor reads 100°C or less 3 minutes later.	•Check refrigerant circuit and refrigerant amount. •Refer to 11-5.ⓧ "Check of LEV".	
9		4-time flash 2.5 seconds OFF	Fin temperature /P.C. board temperature thermistor overheat protection	Temperature of fin temperature thermistor on the heat sink exceeds 75 ~ 80°C or temperature of P.C. board temperature thermistor on the inverter P.C. board exceeds 70 ~ 75°C.	•Check around outdoor unit. •Check outdoor unit air passage. •Refer to 11-5.Ⓘ "Check of outdoor fan motor".	
10		5-time flash 2.5 seconds OFF	High pressure protection	Indoor coil thermistor exceeds 70°C in HEAT mode. Defrost thermistor exceeds 70°C in COOL mode.	•Check refrigerant circuit and refrigerant amount. •Check stop valve.	
11		8-time flash 2.5 seconds OFF	Compressor synchronous abnormality	The waveform of compressor current is distorted.	•Reconnect connector of compressor. •Refer to 11-5.Ⓐ "How to check inverter/compressor".	
12		10-time flash 2.5 seconds OFF	Outdoor fan motor	Outdoor fan has stopped 3 times in a row within 30 seconds after outdoor fan start-up.	•Refer to 11-5.Ⓙ "Check of outdoor fan motor". •Refer to 11-5.Ⓛ "Check of inverter P.C. board".	
13		12-time flash 2.5 seconds OFF	Each phase current of compressor	Each phase current of compressor cannot be detected normally.	•Refer to 11-5.Ⓐ "How to check inverter/compressor".	
14		13-time flash 2.5 seconds OFF	DC voltage	DC voltage of inverter cannot be detected normally.	•Refer to 11-5.Ⓐ "How to check inverter/compressor".	
15		Outdoor unit operates.	1-time flash 2.5 seconds OFF	Frequency drop by current protection	Current from power outlet is nearing breaker capacity.	The unit is normal, but check the following.
16			3-time flash 2.5 seconds OFF	Frequency drop by high pressure protection	Temperature of indoor coil thermistor exceeds 55°C in HEAT mode, compressor frequency lowers.	•Check if indoor filters are clogged. •Check if refrigerant is short. •Check if indoor/outdoor unit air circulation is short cycled.
				Frequency drop by defrosting in COOL mode	Indoor coil thermistor reads 8°C or less in COOL mode, compressor frequency lowers.	
17		4-time flash 2.5 seconds OFF	Frequency drop by discharge temperature protection	Temperature of discharge temperature thermistor exceeds 111°C, compressor frequency lowers.	•Check refrigerant circuit and refrigerant amount. •Refer to 11-5.ⓧ "Check of LEV". •Refer to 11-5.Ⓒ "Check of outdoor thermistors".	
18		Outdoor unit operates.	7-time flash 2.5 seconds OFF	Low discharge temperature protection	Temperature of discharge temperature thermistor has been 50°C or less for 20 minutes.	•Refer to 11-5.ⓧ "Check of LEV". •Check refrigerant circuit and refrigerant amount.
19			8-time flash 2.5 seconds OFF	PAM protection PAM: Pulse Amplitude Modulation	The overcurrent flows into IGBT (Insulated Gate Bipolar transistor: TR821) or the bus-bar voltage reaches 320 V or more, PAM stops and restarts.	This is not malfunction. PAM protection will be activated in the following cases: 1 Instantaneous power voltage drop. (Short time power failure) 2 When the power supply voltage is high.
	20		9-time flash 2.5 seconds OFF	Inverter check mode	The connector of compressor is disconnected, inverter check mode starts.	•Check if the connector of the compressor is correctly connected. Refer to 11-5.Ⓐ "How to check inverter/compressor".

**NOTE:** 1. The location of LED is illustrated at the right figure. Refer to 11-6.1.  
2. LED is lighted during normal operation.

Inverter P.C. board (Parts side)

The flashing frequency shows the number of times  
(Example) When the flashing frequency is "2".

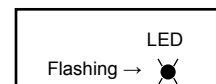
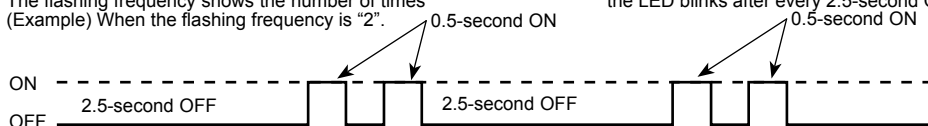

# MUZ-FD50VA

No.	Symptom	LED indication		Abnormal point/ Condition	Condition	Remedy
		LED1(Red)	LED2(Yellow)			
1	Outdoor unit does not operate.	Lightning	Twice	Outdoor power system	Overcurrent protection stop is continuously performed 3 times within 1 minute after the compressor gets started, or when converter protection stop or bus-bar voltage protection stop is continuously performed three times within 3 minutes after start-up.	<ul style="list-style-type: none"> <li>Check the connection of the compressor connecting wire.</li> <li>Refer to 11-5.Ⓐ "How to check inverter/compressor".</li> <li>Check the stop valve.</li> </ul>
2		Lightning	3 times	Discharge temperature thermistor	A short circuit is detected in the thermistor during operation, or when an open circuit is detected in the thermistor after 10 minutes of compressor start-up.	<ul style="list-style-type: none"> <li>Refer to 11-5.Ⓒ "Check of outdoor thermistors".</li> </ul>
3		Lightning	4 times	Fin temperature thermistor P.C. board temperature thermistor	A short or open circuit is detected in the thermistor during operation.	<ul style="list-style-type: none"> <li>Refer to 11-5.Ⓒ "Check of outdoor thermistors".</li> <li>Replace the outdoor electronic control P.C. board.</li> </ul>
4		Lightning	5 times	Ambient temperature thermistor Outdoor heat exchanger temperature thermistor Defrost thermistor	A short or open circuit is detected in the thermistor during operation. A short circuit is detected in the thermistor during operation, or an open circuit is detected in the thermistor after 5 minutes (in cooling) and 10 minutes (in heating) of compressor start-up. A short circuit is detected in the thermistor during operation, or an open circuit is detected in the thermistor after 5 minutes of compressor start-up.	<ul style="list-style-type: none"> <li>Refer to 11-5.Ⓒ "Check of outdoor thermistors".</li> </ul>
5		Lightning	6 times	Serial signal	The communication fails between the indoor and outdoor unit 3 minutes.	<ul style="list-style-type: none"> <li>Refer to 11-5.Ⓜ "How to check miswiring and serial signal error."</li> </ul>
6		Lightning	7 times	Nonvolatile memory data	The nonvolatile memory data cannot be read properly.	<ul style="list-style-type: none"> <li>Replace the outdoor electronic control P.C. board.</li> </ul>
7		Lightning	8 times	Current sensor	Current sensor protection stop is continuously performed twice.	<ul style="list-style-type: none"> <li>Replace the power board.</li> </ul>
8		Lightning	11 times	Communication error between P.C. boards	The communication protection stop between boards is continuously performed twice.	<ul style="list-style-type: none"> <li>Check the connecting wire between outdoor electronic control P.C. board and power board.</li> </ul>
9		Lightning	12 times	Zero cross detecting circuit	The protection stop of the zero cross detecting circuit is continuously performed 10 times.	<ul style="list-style-type: none"> <li>Check the connecting wire among outdoor electronic control P.C. board, noise filter P.C. board and power board.</li> </ul>
10	'Outdoor unit stops and restarts 3 minutes later' is repeated.	Twice	Goes out	IPM protection	Overcurrent is detected after 30 seconds of compressor start-up.	<ul style="list-style-type: none"> <li>Reconnect compressor connector.</li> <li>Refer to 11-5.Ⓐ "How to check inverter/compressor".</li> <li>Check the stop valve.</li> <li>Check the power module (PAM module).</li> </ul>
11				Lock protection	Overcurrent is detected within 30 seconds of compressor start-up.	
12		3 times	Goes out	Discharge temperature protection	Discharge temperature exceeds 116°C during operation and compressor stops. Compressor can restart if discharge temperature thermistor reads 100°C or less 3 minutes later.	<ul style="list-style-type: none"> <li>Check the amount of gas and refrigerant circuit.</li> <li>Refer to 11-5.Ⓔ "Check of LEV".</li> </ul>
13		4 times	Goes out	Fin temperature protection P.C. board temperature protection	The fin temperature exceeds 87°C during operation. The P.C. board temperature exceeds 70°C during operation.	<ul style="list-style-type: none"> <li>Check around outdoor unit.</li> <li>Check outdoor unit air passage.</li> <li>Refer to 11-5.Ⓛ "Check of outdoor fan motor".</li> </ul>
14		5 times	Goes out	High-Pressure protection	The outdoor heat exchanger temperature exceeds 70°C during cooling or indoor gas pipe temperature exceeds 70°C during heating.	<ul style="list-style-type: none"> <li>Check the amount of gas and the refrigerant circuit.</li> <li>Check the stop valve.</li> </ul>
15		8 times	Goes out	Converter protection	A failure is detected in the operation of the converter during operation.	<ul style="list-style-type: none"> <li>Replace the power board.</li> </ul>
16		9 times	Goes out	Bus-bar voltage protection (1)	The bus-bar voltage exceeds 400 V or falls to 200 V or below during compressor operating.	<ul style="list-style-type: none"> <li>Check the voltage of power supply.</li> <li>Replace the power board or the outdoor electronic control P.C. board.</li> <li>Refer to 11-5.Ⓔ "Check of bus-bar voltage".</li> </ul>
17				Bus-bar voltage protection (2)	The bus-bar voltage exceeds 400 V or falls to 50 V or below during compressor operating.	
18		13 times	Goes out	Outdoor fan motor	Failure occurs continuously three times within 30 seconds after the fan gets started.	<ul style="list-style-type: none"> <li>Refer to 11-5.Ⓛ "Check of outdoor fan motor".</li> </ul>
19	Lighting	8 times	Current sensor protection	A short or open circuit is detected in the current sensor during compressor operating.	<ul style="list-style-type: none"> <li>Replace the power board.</li> </ul>	
20	Lighting	11 times	Communication between P.C. boards protection	Communication error occurs between the outdoor electronic control P.C. board and power board for more than 10 seconds	<ul style="list-style-type: none"> <li>Check the connecting wire between outdoor electronic control P.C. board and power board.</li> </ul>	
21	Lighting	12 times	Zero cross detecting circuit protection	Zero cross signal cannot be detected while the compressor is operating.	<ul style="list-style-type: none"> <li>Check the connecting wire among outdoor electronic control P.C. board, noise filter P.C. board and power board.</li> </ul>	

**NOTE:** 1. The location of LED is illustrated at the right figure. Refer to 11-6.2.  
2. LED is lighted during normal operation.

Outdoor electronic control P.C. board(Parts side)

The flashing frequency shows the number of times the LED blinks after every 2.5-second OFF.  
(Example) When the flashing frequency is "2".

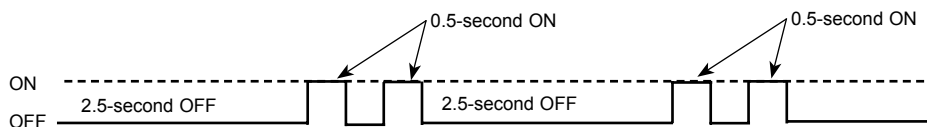
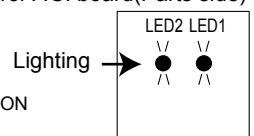



No.	Symptom	LED indication		Abnormal point/ Condition	Condition	Remedy
		LED1(Red)	LED2(Yellow)			
20	Outdoor unit operates.	Once	Lighting	Primary current protection	The input current exceeds 15 A.	These symptoms do not mean any abnormality of the product, but check the following points. • Check if indoor filters are clogged. • Check if refrigerant is short. • Check if indoor/outdoor unit air circulation is short cycled.
				Secondary current protection	The current of the compressor exceeds 13 A.	
21		Twice	Lighting	High-Pressure protection	The indoor gas pipe temperature exceeds 45°C during heating.	
				Defrosting in cooling	The indoor gas pipe temperature falls 3°C or below during cooling.	
22		3 times	Lighting	Discharge temperature protection	The discharge temperature exceeds 100°C during operation.	• Check refrigerant circuit and refrigerant amount. • Refer to 11-5.Ⓢ "Check of LEV". • Refer to 11-5.Ⓢ "Check of outdoor thermistors".
23		4 times	Lighting	Low discharge temperature protection	The frequency of the compressor is kept 80 Hz or more and the discharge temperature is kept under 39°C for more than 20 minutes.	• Refer to 11-5.Ⓢ "Check of LEV". • Check refrigerant circuit and refrigerant amount.
24		5 times	Lighting	Cooling high-pressure protection	The outdoor heat exchanger temperature exceeds 58°C during operation.	This symptom does not mean any abnormality of the product, but check the following points. • Check if indoor filters are clogged. • Check if refrigerant is short. • Check if indoor/outdoor unit air circulation is short cycled.
25	Outdoor unit operates	9 times	Lighting	Inverter check mode	The unit is operated with emergency operation switch.	—
26		Lighting	Lighting	Normal	—	—

### 11-4. TROUBLE CRITERION OF MAIN PARTS

#### MUZ-FD25VA MUZ-FD25VAH MUZ-FD35VA MUZ-FD35VAH MUZ-FD50VA

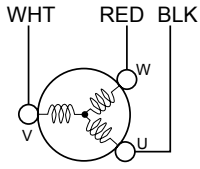
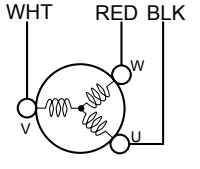
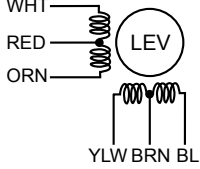
Part name	Check method and criterion	Figure										
Defrost thermistor (RT61) Ambient temperature thermistor (RT65) Fin temperature thermistor (RT64) Outdoor heat exchanger temperature thermistor (RT68)	Measure the resistance with a tester.  Refer to 11-6. "Test point diagram and voltage," 1. "Inverter P.C. board", or 2. "Outdoor electronic control P.C. board", the chart of thermistor.											
Discharge temperature thermistor (RT62)	Measure the resistance with a tester. Before measurement, hold the thermistor with your hands to warm it up.  Refer to 11-6. "Test point diagram and voltage," 1. "Inverter P.C. board", or 2. "Outdoor electronic control P.C. board", the chart of thermistor.											
Compressor	Measure the resistance between terminals using a tester. (Temperature: -10 ~ 40°C) <table border="1" style="margin-left: 20px;"> <thead> <tr> <th colspan="3">Normal</th> </tr> <tr> <th>U-V</th> <th>25/35</th> <th>50</th> </tr> </thead> <tbody> <tr> <td>U-W</td> <td rowspan="2">0.82 ~ 1.11 Ω</td> <td rowspan="2">0.60 ~ 0.82 Ω</td> </tr> <tr> <td>V-W</td> </tr> </tbody> </table>	Normal			U-V	25/35	50	U-W	0.82 ~ 1.11 Ω	0.60 ~ 0.82 Ω	V-W	
Normal												
U-V	25/35	50										
U-W	0.82 ~ 1.11 Ω	0.60 ~ 0.82 Ω										
V-W												
Outdoor fan motor	Measure the resistance between lead wires using a tester. (Temperature: -10 ~ 40°C) <table border="1" style="margin-left: 20px;"> <thead> <tr> <th>Color of lead wire</th> <th colspan="2">Normal</th> </tr> <tr> <td>RED - BLK</td> <td>25/35</td> <td>50</td> </tr> </thead> <tbody> <tr> <td>BLK - WHT</td> <td rowspan="2">11 ~ 16 Ω</td> <td rowspan="2">12 ~ 17 Ω</td> </tr> <tr> <td>WHT - RED</td> </tr> </tbody> </table>	Color of lead wire	Normal		RED - BLK	25/35	50	BLK - WHT	11 ~ 16 Ω	12 ~ 17 Ω	WHT - RED	
Color of lead wire	Normal											
RED - BLK	25/35	50										
BLK - WHT	11 ~ 16 Ω	12 ~ 17 Ω										
WHT - RED												
R. V. coil (21S4)	Measure the resistance using a tester. (Temperature: -10 ~ 40°C) <table border="1" style="margin-left: 20px;"> <thead> <tr> <th colspan="2">Normal</th> </tr> <tr> <th>25/35</th> <th>50</th> </tr> </thead> <tbody> <tr> <td>1.19 ~ 1.78 kΩ</td> <td>1.15 ~ 1.71 kΩ</td> </tr> </tbody> </table>	Normal		25/35	50	1.19 ~ 1.78 kΩ	1.15 ~ 1.71 kΩ					
Normal												
25/35	50											
1.19 ~ 1.78 kΩ	1.15 ~ 1.71 kΩ											
Expansion valve coil (LEV)	Measure the resistance using a tester. (Temperature: -10 ~ 40°C) <table border="1" style="margin-left: 20px;"> <thead> <tr> <th>Color of lead wire</th> <th>Normal</th> </tr> </thead> <tbody> <tr> <td>WHT - RED</td> <td rowspan="4">37 ~ 54 Ω</td> </tr> <tr> <td>RED - ORN</td> </tr> <tr> <td>YLW - BRN</td> </tr> <tr> <td>BRN - BLU</td> </tr> </tbody> </table>	Color of lead wire	Normal	WHT - RED	37 ~ 54 Ω	RED - ORN	YLW - BRN	BRN - BLU				
Color of lead wire	Normal											
WHT - RED	37 ~ 54 Ω											
RED - ORN												
YLW - BRN												
BRN - BLU												
Defrost heater <b>MUZ-FD•VAH</b>	Measure the resistance using a tester. (Temperature: -10 ~ 40°C) <table border="1" style="margin-left: 20px;"> <thead> <tr> <th>Normal</th> </tr> </thead> <tbody> <tr> <td>349 ~ 428 Ω</td> </tr> </tbody> </table>	Normal	349 ~ 428 Ω									
Normal												
349 ~ 428 Ω												
High pressure switch (HPS) <b>MUZ-FD50</b>	<table border="1" style="margin-left: 20px;"> <thead> <tr> <th colspan="2">Pressure</th> </tr> </thead> <tbody> <tr> <td>3.7 ± 0.15 MPa</td> <td>Close</td> </tr> <tr> <td>4.8 <sup>+0.05</sup>/<sub>-0.1</sub> MPa</td> <td>Open</td> </tr> </tbody> </table>	Pressure		3.7 ± 0.15 MPa	Close	4.8 <sup>+0.05</sup> / <sub>-0.1</sub> MPa	Open					
Pressure												
3.7 ± 0.15 MPa	Close											
4.8 <sup>+0.05</sup> / <sub>-0.1</sub> MPa	Open											

## 11-5. TROUBLESHOOTING FLOW

### A How to check inverter/compressor

#### MUZ-FD25/35

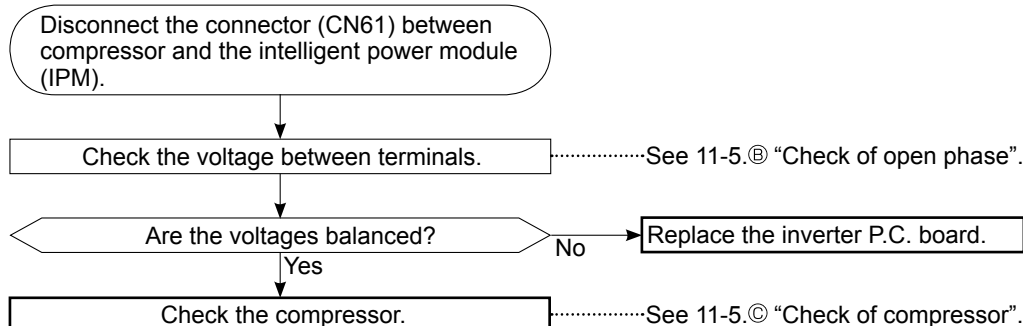

#### MUZ-FD50

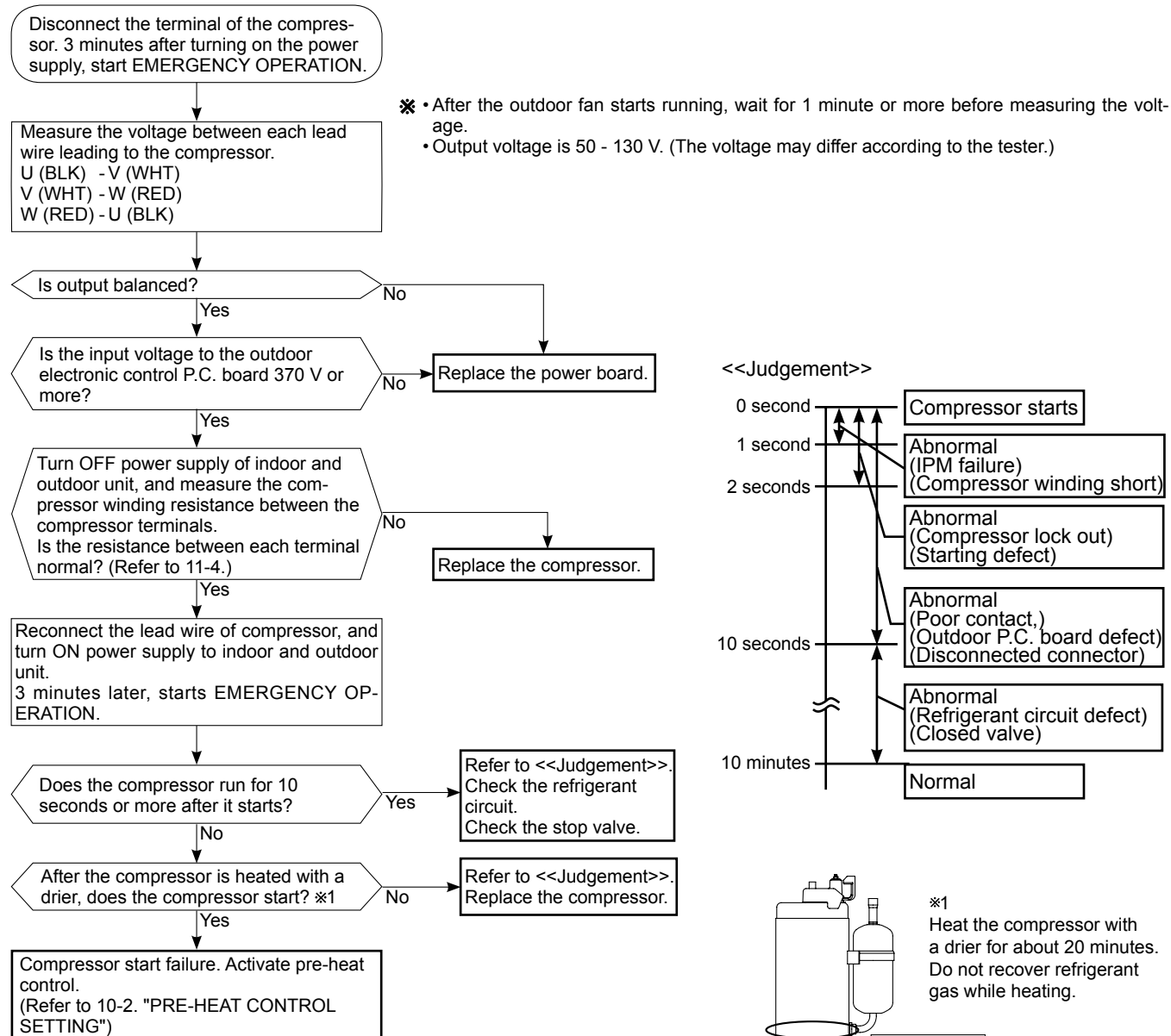



**Ⓑ Check of open phase**

**MUZ-FD25/35**

- With the connector between the compressor and the intelligent power module disconnected, activate the inverter and check if the inverter is normal by measuring **the balance of voltage** between the terminals.

Output voltage is 50 - 130 V. (The voltage may differ according to the tester.)

<< Operation method >>

Start cooling or heating operation by pressing EMERGENCY OPERATION switch on the indoor unit. (TEST RUN OPERATION: Refer to 8-3.)

<< Measurement point >>

At 3 points

BLK (U)-WHT (V)

※ Measure AC voltage between the lead wires at 3 points.

BLK (U)-RED (W)

WHT(V)-RED (W)

- NOTE:**
1. Output voltage varies according to power supply voltage.
  2. Measure the voltage by analog type tester.
  3. During this check, LED of the inverter P.C. board flashes 9 times. (Refer to 11-6.1.)

**Ⓒ Check of compressor**

**MUZ-FD25/35**

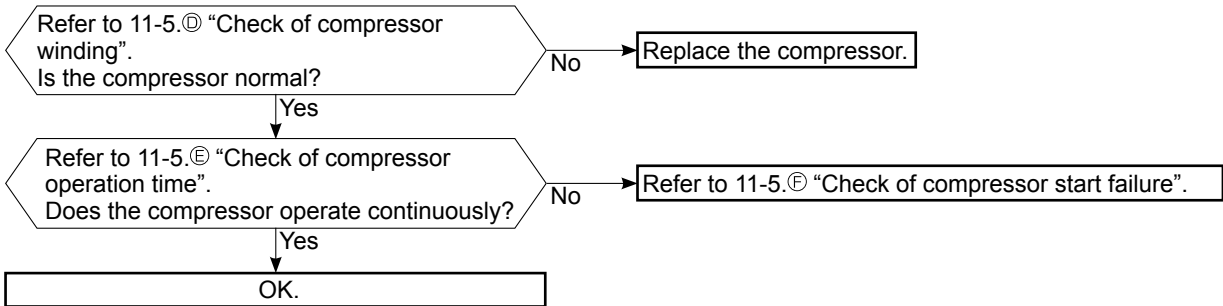

## D Check of compressor winding

### MUZ-FD25/35

- Disconnect the connector (CN61) between the compressor and intelligent power module, and measure the resistance between the compressor terminals.

<<Measurement point>>

at 3 points

BLK-WHT

BLK-RED

WHT-RED

※ Measure the resistance between the lead wires at 3 points.

<<Judgement>>

Refer to 11-4.

0 [Ω] .....Abnormal [short]

Infinite [Ω] .....Abnormal [open]

**NOTE:** Be sure to zero the ohmmeter before measurement.

## E Check of compressor operation time

### MUZ-FD25/35

- Connect the compressor and activate the inverter. Then measure the time until the inverter stops due to over current.

<<Operation method>>

Start heating or cooling operation by pressing EMERGENCY OPERATION switch on the indoor unit.

(TEST RUN OPERATION: Refer to 8-3.)

<<Measurement>>

Measure the time from the start of compressor to the stop of compressor due to overcurrent.

<<Judgement>>

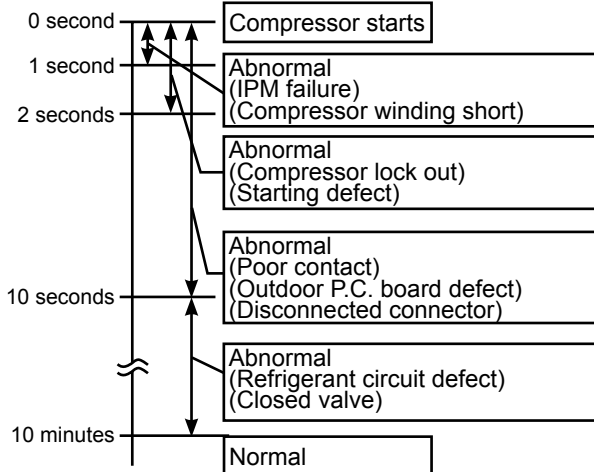

## F Check of compressor start failure

### MUZ-FD25/35

Confirm that ①~④ is normal.

•Electrical circuit check

①. Contact of the compressor connector (Including CN61)

②. Output voltage of inverter P.C. board and balance of them (See 11-5.③)

③. Direct current voltage between DB61(+) and (-) on the inverter P.C. board

④. Voltage between outdoor terminal block S1-S2

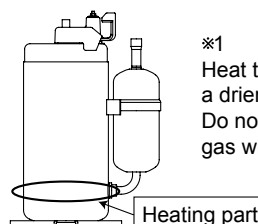
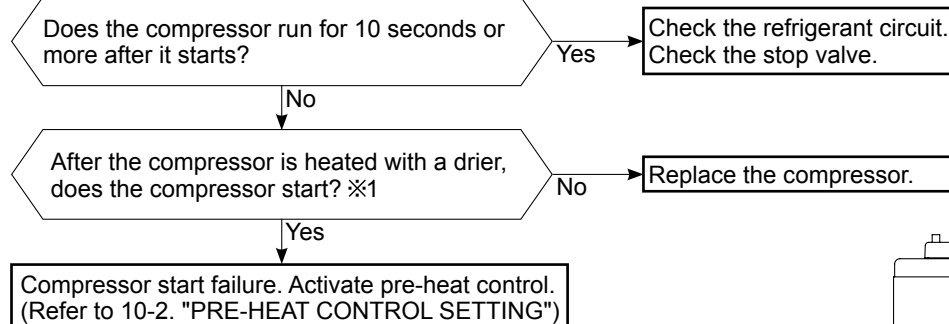

※1  
Heat the compressor with a drier for about 20 minutes. Do not recover refrigerant gas while heating.

### G Check of outdoor thermistors

Disconnect the connector of thermistor in the outdoor P.C. board (see below table), and measure the resistance of thermistor.

Is the resistance of thermistor normal?  
(Refer to 11-6.1. or 11-6.2.)

No

Replace the thermistor except RT64.  
When RT64 is abnormal, replace the inverter P.C. board or the outdoor power board.

Yes

Reconnect the connector of thermistor.  
Turn ON the power supply and press EMERGENCY OPERATION switch.

Does the unit operate for 10 minutes or more without showing thermistor abnormality?

No

Replace the inverter P.C. board or the outdoor electronic control P.C. board.

Yes

OK.  
(Cause is poor contact.)

#### MUZ-FD25/35

Thermistor	Symbol	Connector, Pin No.	Board
Defrost	RT61	Between CN641 pin1 and pin2	Inverter P.C. board
Discharge temperature	RT62	Between CN641 pin3 and pin4	
Fin temperature	RT64	Between CN642 pin1 and pin2	
Ambient temperature	RT65	Between CN643 pin1 and pin2	
Outdoor heat exchanger temperature	RT68	Between CN644 pin1 and pin3	

#### MUZ-FD50

Thermistor	Symbol	Connector, Pin No.	Board
Defrost	RT61	Between CN661 pin 1 and pin 2	Outdoor electronic control P.C. board
Discharge temperature	RT62	Between CN661 pin 3 and pin 4	
Outdoor heat exchanger temperature	RT68	Between CN661 pin 7 and pin 8	
Ambient temperature	RT65	Between CN663 pin 1 and pin 2	Outdoor power board
Fin temperature	RT64	Between CN3 pin 1 and pin 2	

### H Check of R.V. coil

#### MUZ-FD25/35

- ※ First of all, measure the resistance of R.V. coil to check if the coil is defective. Refer to 11-4.
- ※ In case CN721 is disconnected or R.V. coil is open, voltage is generated between the terminal pins of the connector although no signal is being transmitted to R.V. coil.  
Check if CN721 is connected.

#### Unit operates COOL mode even if it is set to HEAT mode.

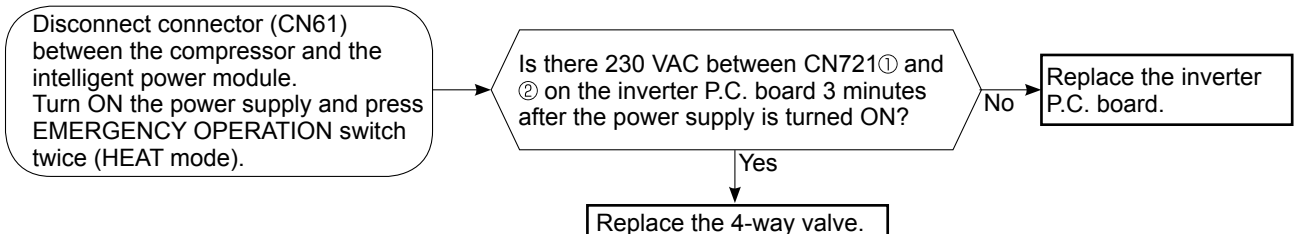

#### Unit operates HEAT mode even if it is set to COOL mode.

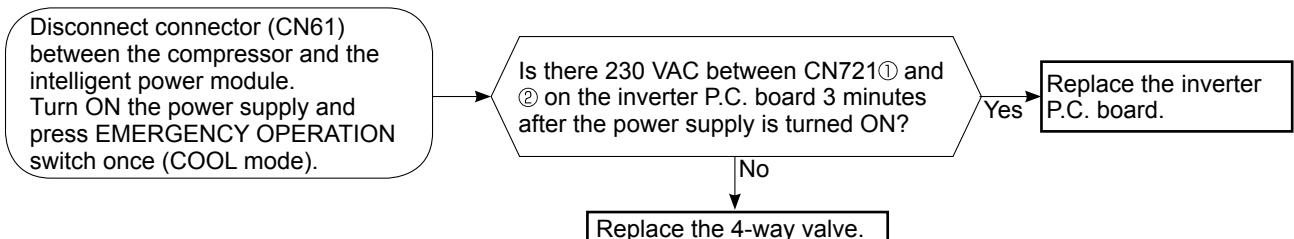

## MUZ-FD50

### • Heating operation does not work.

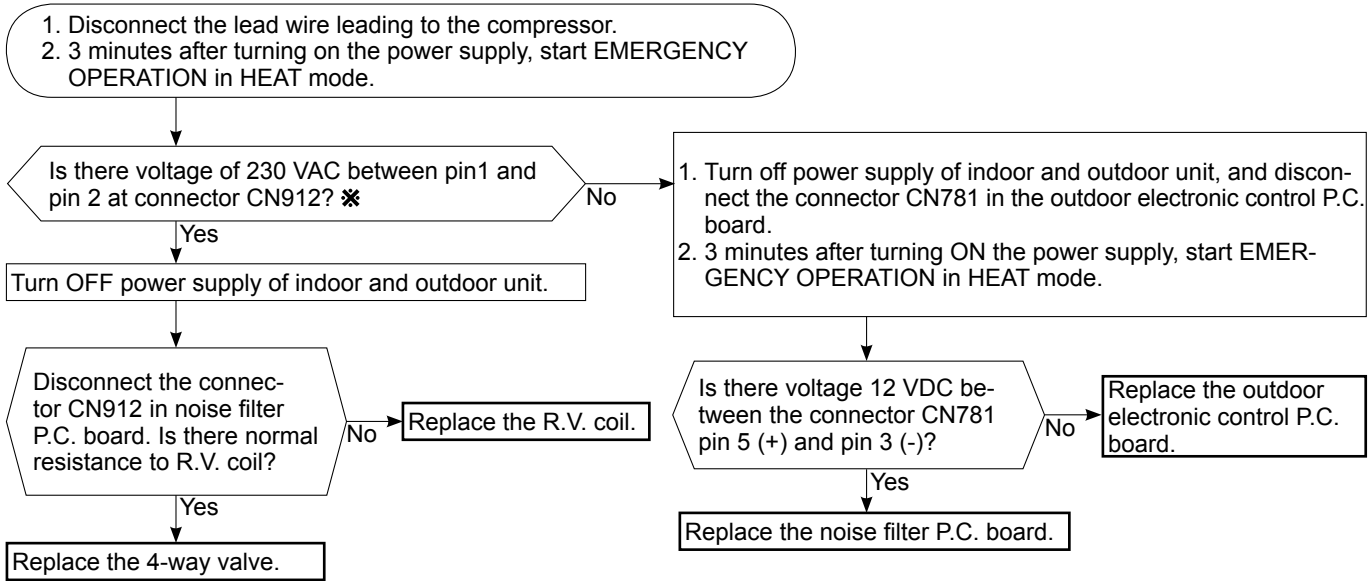

### • Cooling operation does not work.

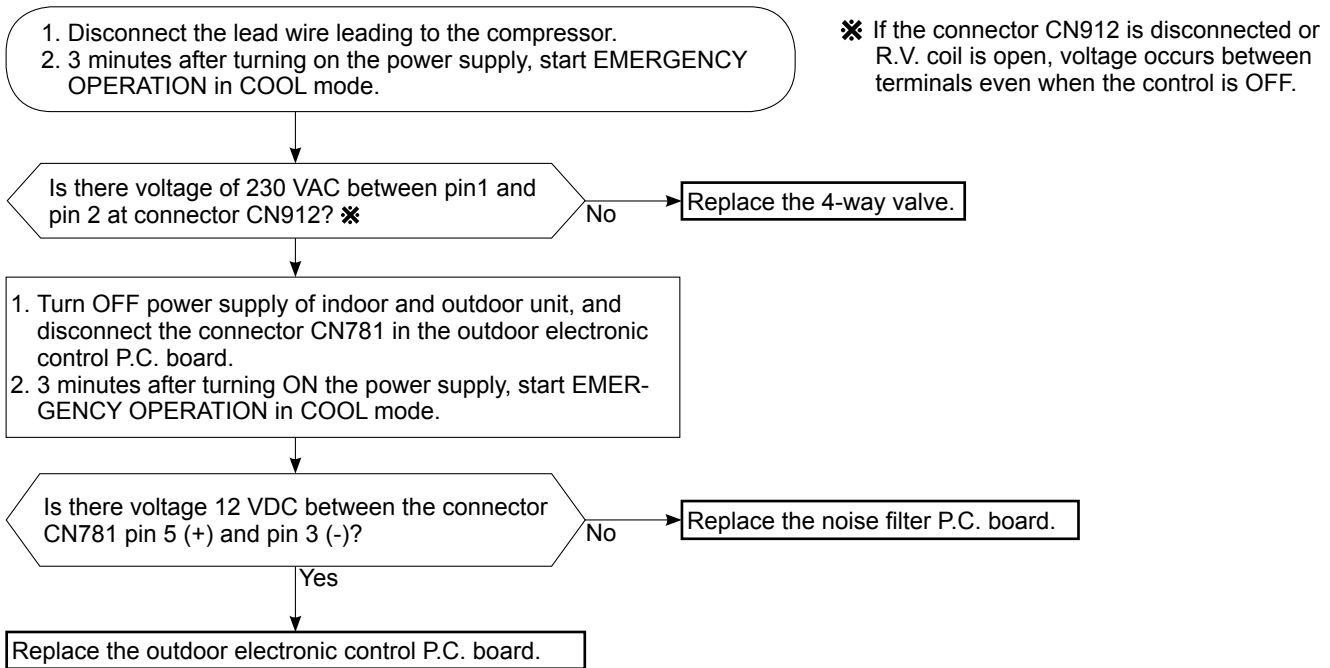

**① Check of outdoor fan motor**

**MUZ-FD25/35**

Disconnect CN932 from the inverter P.C. board, and measure the resistance of the outdoor fan motor.

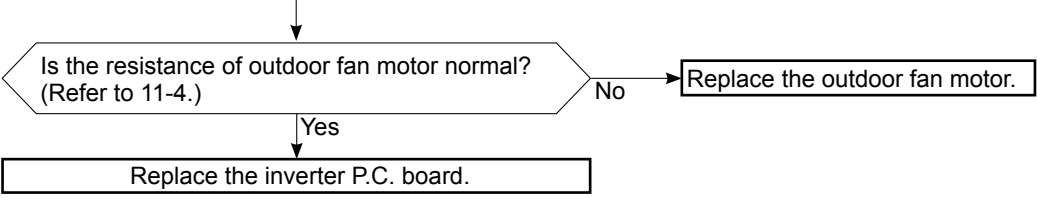

**MUZ-FD50**

Disconnect CN932 from the outdoor electronic control P.C. board, and measure the resistance of the outdoor fan motor.

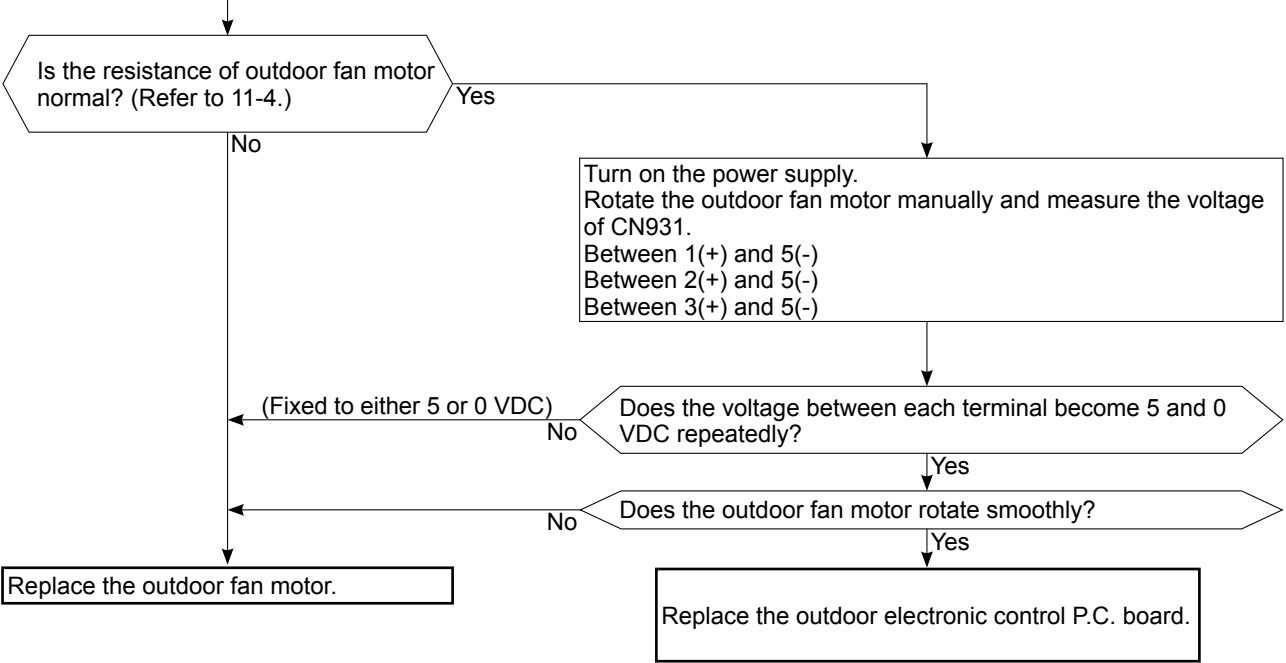

## Ⓜ Check of power supply

### MUZ-FD25/35

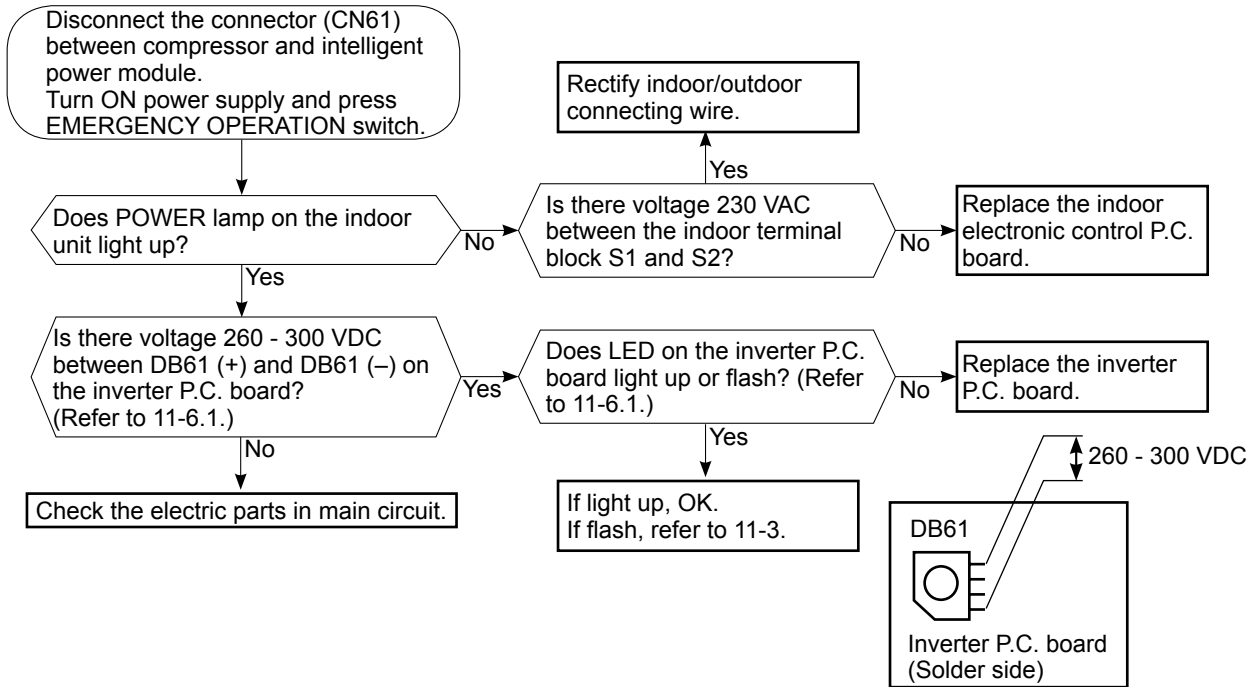

### MUZ-FD50

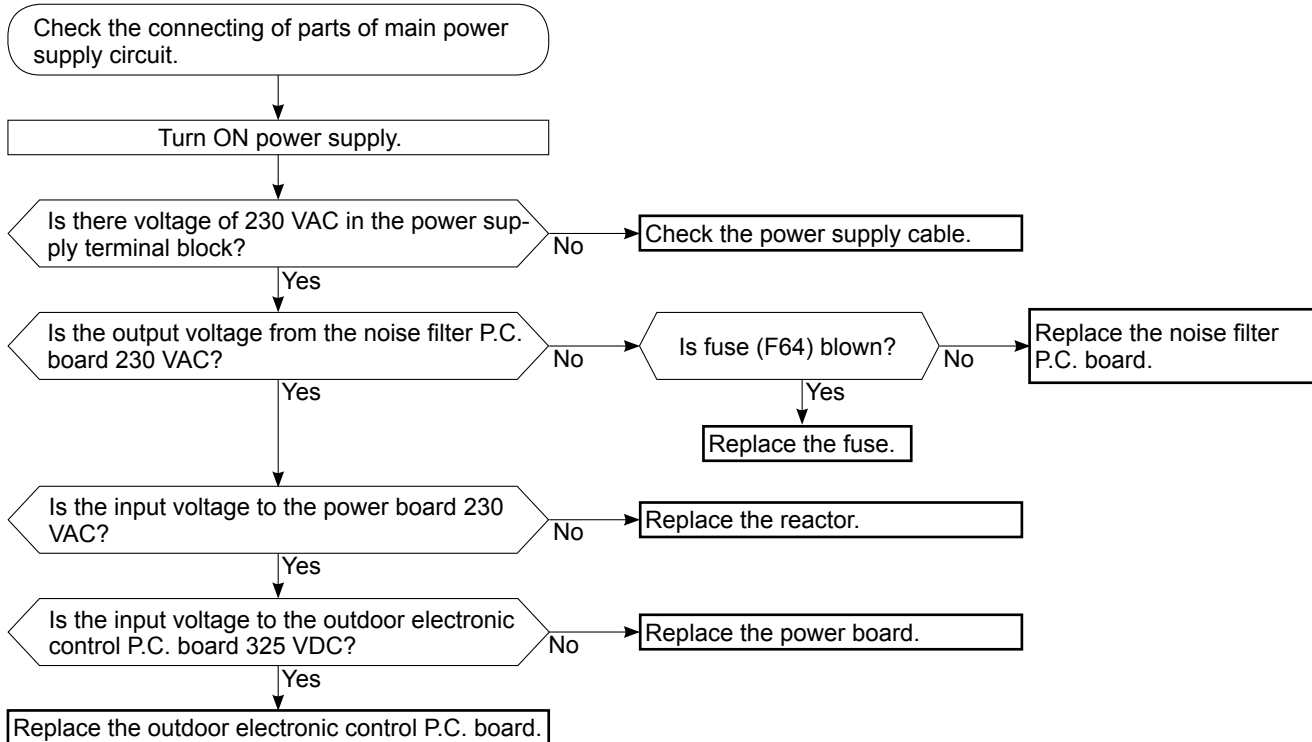

## K Check of LEV (Expansion valve)

Turn ON the power supply.  
 <Preparation of the remote controller>  
 ① While pressing both OPERATION SELECT button and TOO COOL button on the remote controller at the same time, press RESET button.  
 ② First, release RESET button.  
 Hold down the other two buttons for another 3 seconds. Confirm that the indicators on the LCD screen shown in the right figure are all displayed. Then release the buttons.

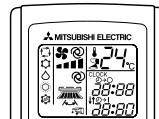
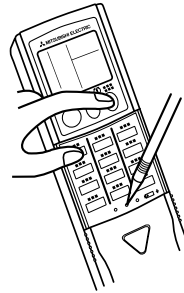

Press OPERATE/STOP (ON/OFF) button of the remote controller (the set temperature is displayed) with the remote controller headed towards the indoor unit. \*1

Expansion valve operates in full-opening direction.

Do you hear the expansion valve "click, click....." ?  
 Do you feel the expansion valve vibrate on touching it ?

Yes → OK

No

Is LEV coil properly fixed to the expansion valve?

No → Properly fix the LEV coil to the expansion valve.

Yes

Does the resistance of LEV coil have the characteristics? (Refer to 11-4.)

Yes → Measure each voltage between connector pins of CN724 on the inverter P.C. board or CN795 on the outdoor electronic control P.C. board.

No

Replace the LEV coil.

Measure each voltage between connector pins of CN724 on the inverter P.C. board or CN795 on the outdoor electronic control P.C. board.  
 1. Pin③(-) — Pin①(+)  
 2. Pin④(-) — Pin①(+)  
 3. Pin⑤(-) — Pin①(+)  
 4. Pin⑥(-) — Pin①(+)  
 Is there about 3 ~ 5 VAC between each?  
**NOTE:** Measure the voltage by an analog tester.

Replace the inverter P.C. board or the outdoor electronic control P.C. board.

Yes

Replace the expansion valve.

\*1. Regardless of normal or abnormal condition, a short beep is emitted once the signal is received.

**NOTE:** After check of LEV, do the undermentioned operations.

1. Turn OFF the power supply and turn it ON again.
2. Press RESET button on the remote controller.



**Ⓛ Check of inverter P.C. board**

**MUZ-FD25/35**

Check the outdoor fan motor.  
(Refer to 11-5.①.)

Is the fuse (F901) blown on the in-  
verter P.C. board?

No

Check the connection of the connectors  
(CN932) of the outdoor fan motor.  
If the connection is poor, make it correct.

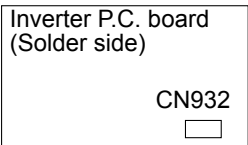

Operate the outdoor unit by starting  
EMERGENCY OPERATION.

Check the LED indication on the in-  
verter P.C. board.  
Does the LED flash 10 times?

Yes  
(10-time flash)

No

Check the corresponding parts  
following LED indication.  
(Refer to 11-3.)

Replace the inverter P.C. board.

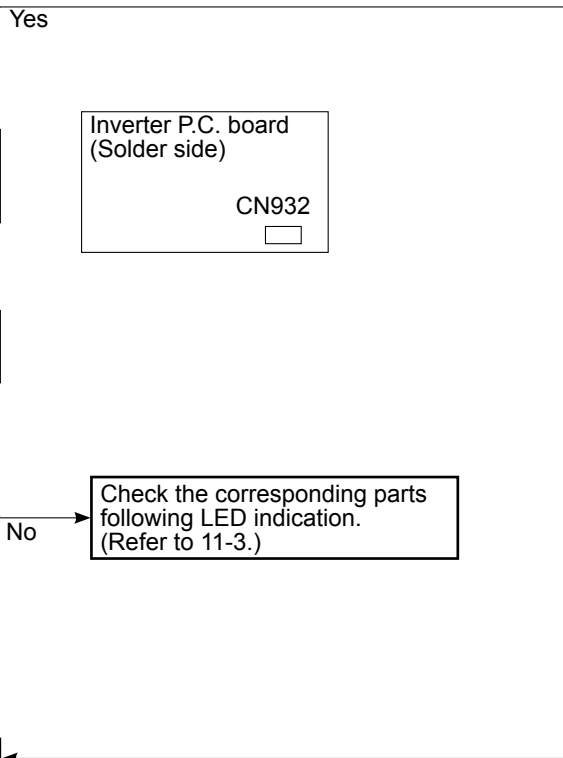

# M How to check miswiring and serial signal error

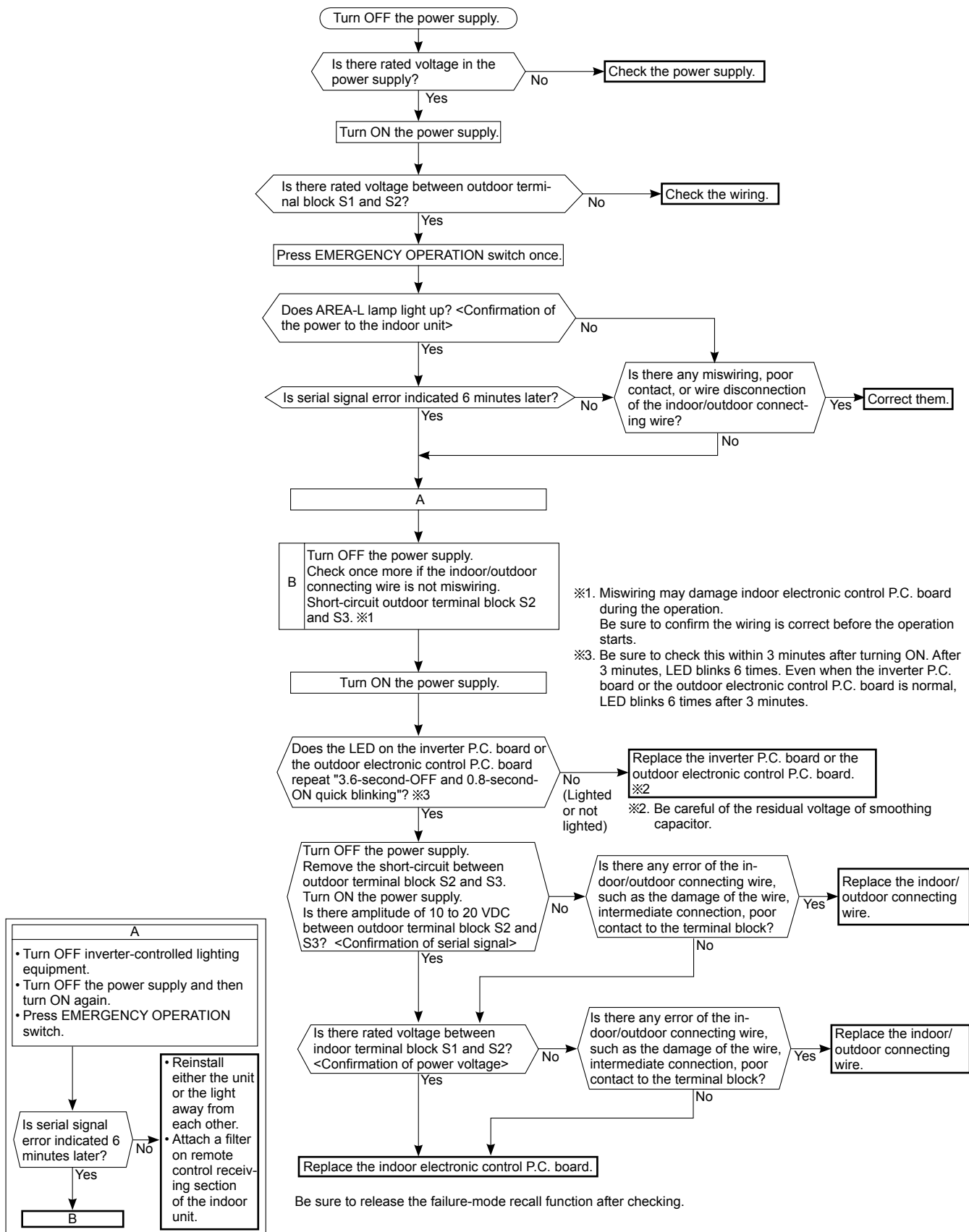

## N Electromagnetic noise enters into TV sets or radios

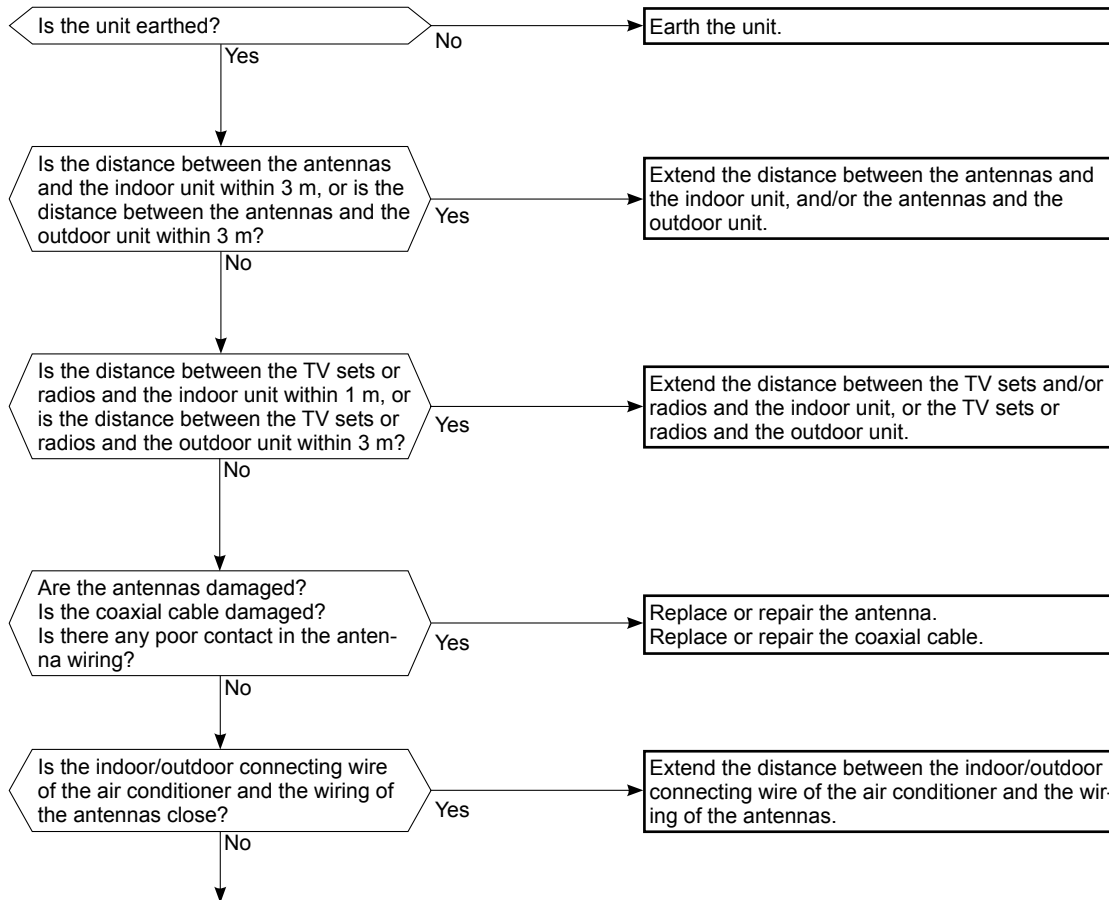

Even if all of the above conditions are fulfilled, the electromagnetic noise may enter, depending on the electric field strength or the installation condition (combination of specific conditions such as antennas or wiring). Check the following before asking for service.

1. Devices affected by the electromagnetic noise  
TV sets, radios (FM/AM broadcast, shortwave)
2. Channel, frequency, broadcast station affected by the electromagnetic noise
3. Channel, frequency, broadcast station unaffected by the electromagnetic noise
4. Layout of :  
indoor/outdoor unit of the air conditioner, indoor/outdoor wiring, earth wire, antennas, wiring from antennas, receiver
5. Electric field intensity of the broadcast station affected by the electromagnetic noise
6. Presence or absence of amplifier such as booster
7. Operation condition of air conditioner when the electromagnetic noise enters in
  - 1) Turn OFF the power supply once, and then turn ON the power supply. In this situation, check for the electromagnetic noise.
  - 2) Within 3 minutes after turning ON the power supply, press OPERATE/STOP (ON/OFF) button on the remote controller for power ON, and check for the electromagnetic noise.
  - 3) After a short time (3 minutes later after turning ON), the outdoor unit starts running. During operation, check for the electromagnetic noise.
  - 4) Press OPERATE/STOP (ON/OFF) button on the remote controller for power OFF, when the outdoor unit stops but the indoor/outdoor communication still runs on. In this situation, check for the electromagnetic noise.

**○ Check of defrost heater**

**MUZ-FD25VAH MUZ-FD35VAH**

Check the following points before checking electric continuity.

1. Does the resistance of ambient temperature thermistor have the characteristics? Refer to 11-6.1.
2. Is the resistance of defrost heater normal? Refer to 11-4.
3. Does the heater protector remain conducted (not open)?
4. Are both ambient temperature thermistor and circuit of defrost heater securely connected to connectors?

In HEAT mode, for more than 5 minutes, let the ambient temperature thermistor continue to read 5°C or below, and let the defrost thermistor continue to read -1°C or below.

**NOTE:** In case both thermistors are more than the above temperature, cool them with cold water etc...

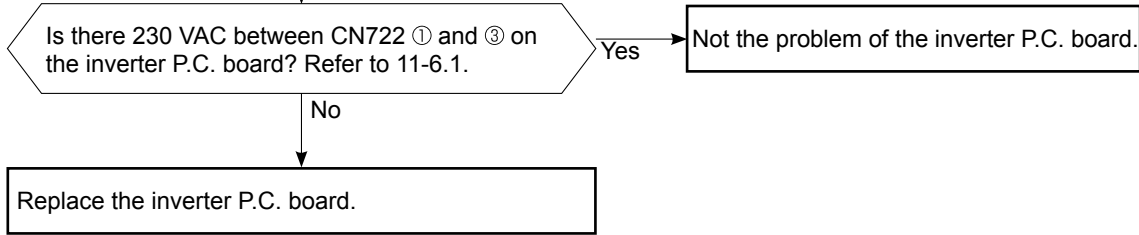

**Ⓟ Check of bus-bar voltage**

**MUZ-FD50**

•Check the voltage of power supply.  
•Confirm outdoor unit failure mode recall function. (Refer to 11-2.2)

Confirm LED1 indication lamp on the outdoor electronic control P.C. board.

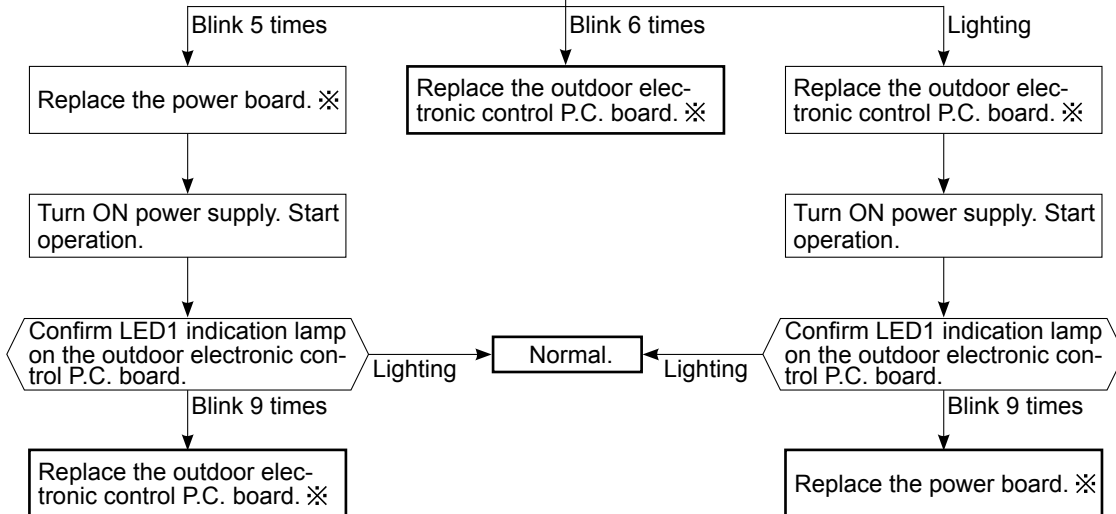

✘ Turn OFF power supply before removing P.C. board.

# 11-6. TEST POINT DIAGRAM AND VOLTAGE

## 1. Inverter P.C. board

### MUZ-FD25VA MUZ-FD25VAH MUZ-FD35VA MUZ-FD35VAH

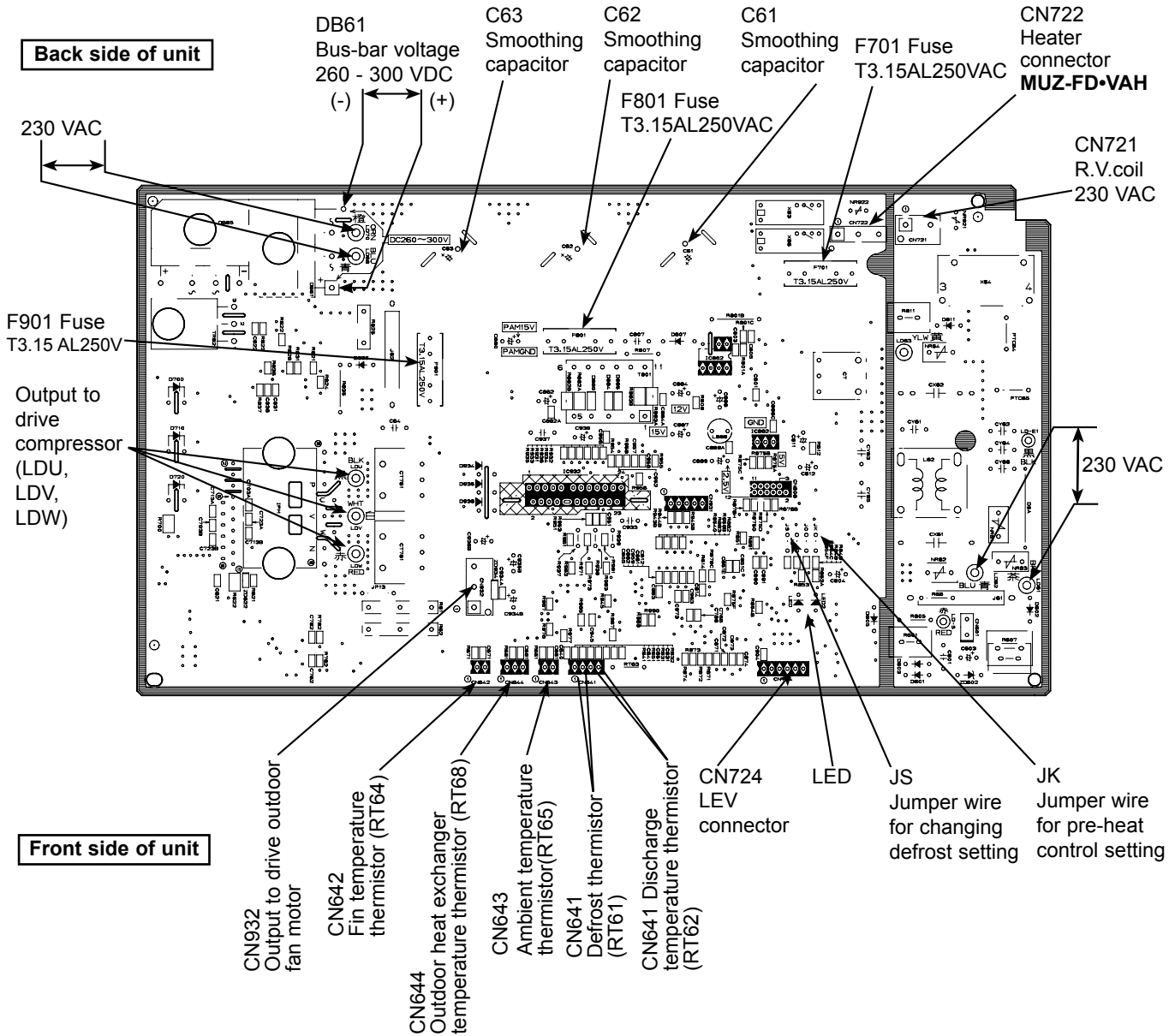

Defrost thermistor (RT61)  
Ambient temperature thermistor (RT65)  
Outdoor heat exchanger temperature thermistor (RT68)

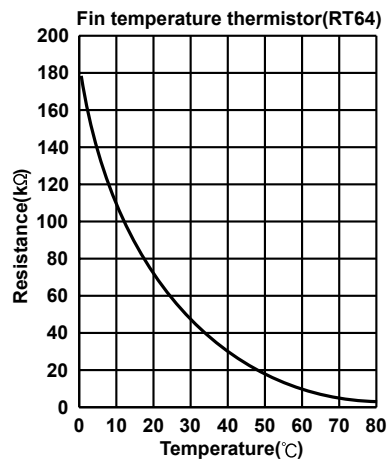
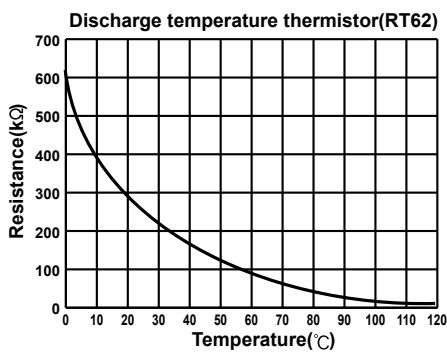
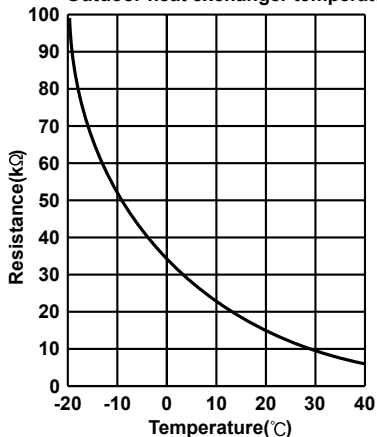

## 2. Outdoor electronic control P.C. board MUZ-FD50VA

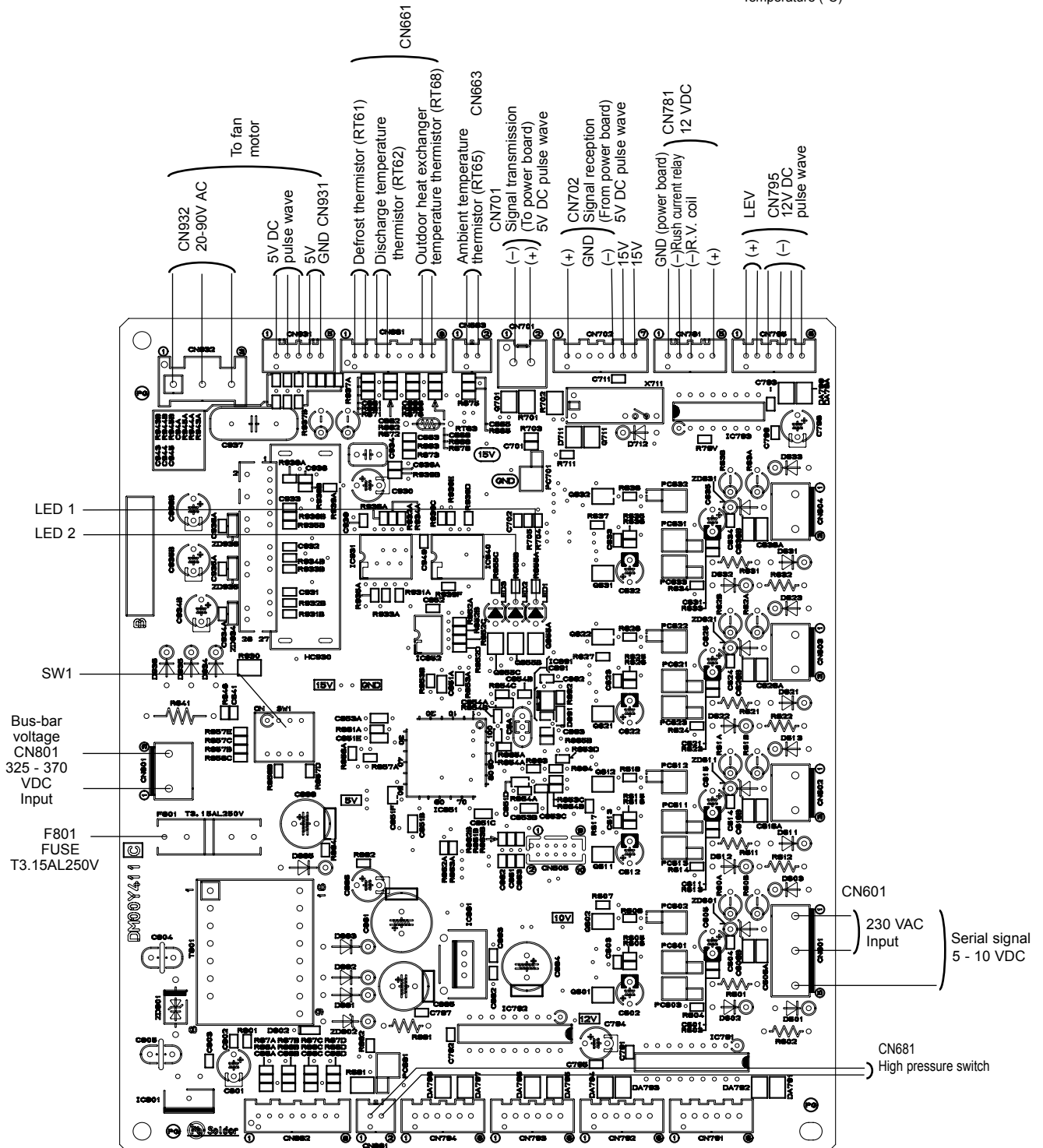
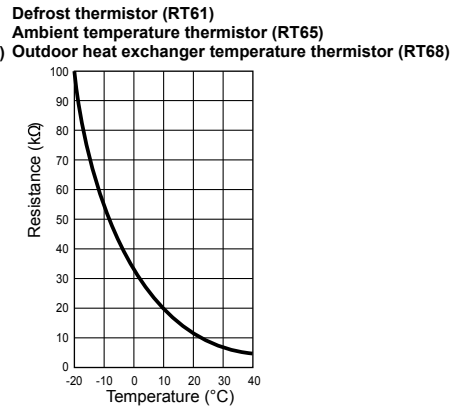
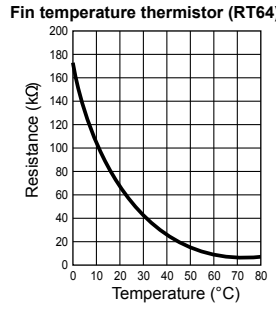
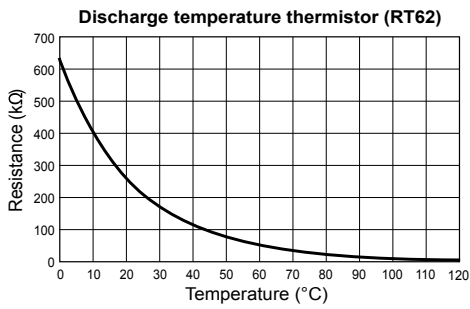

### 3. Noise filter P.C. board MUZ-FD50VA

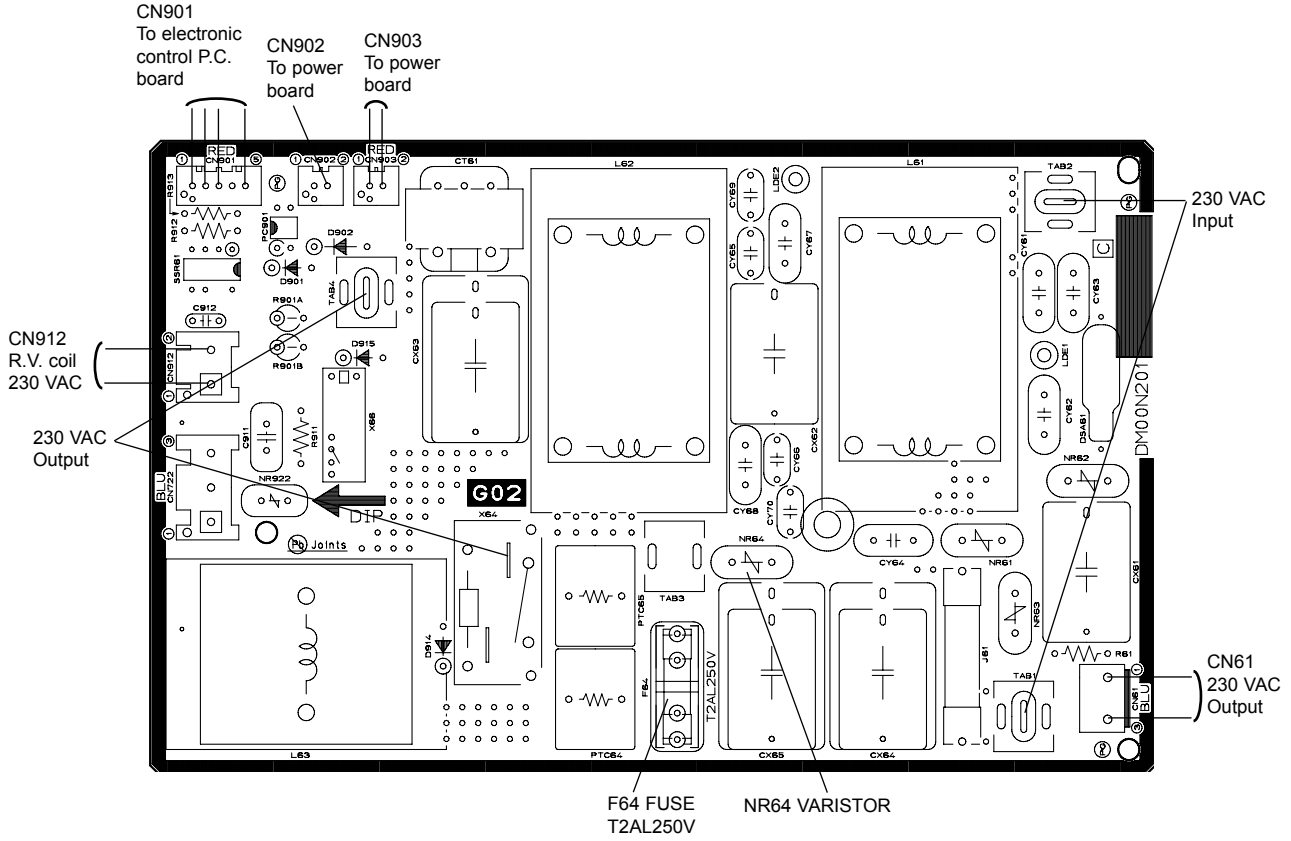

### 4. Outdoor power board MUZ-FD50VA

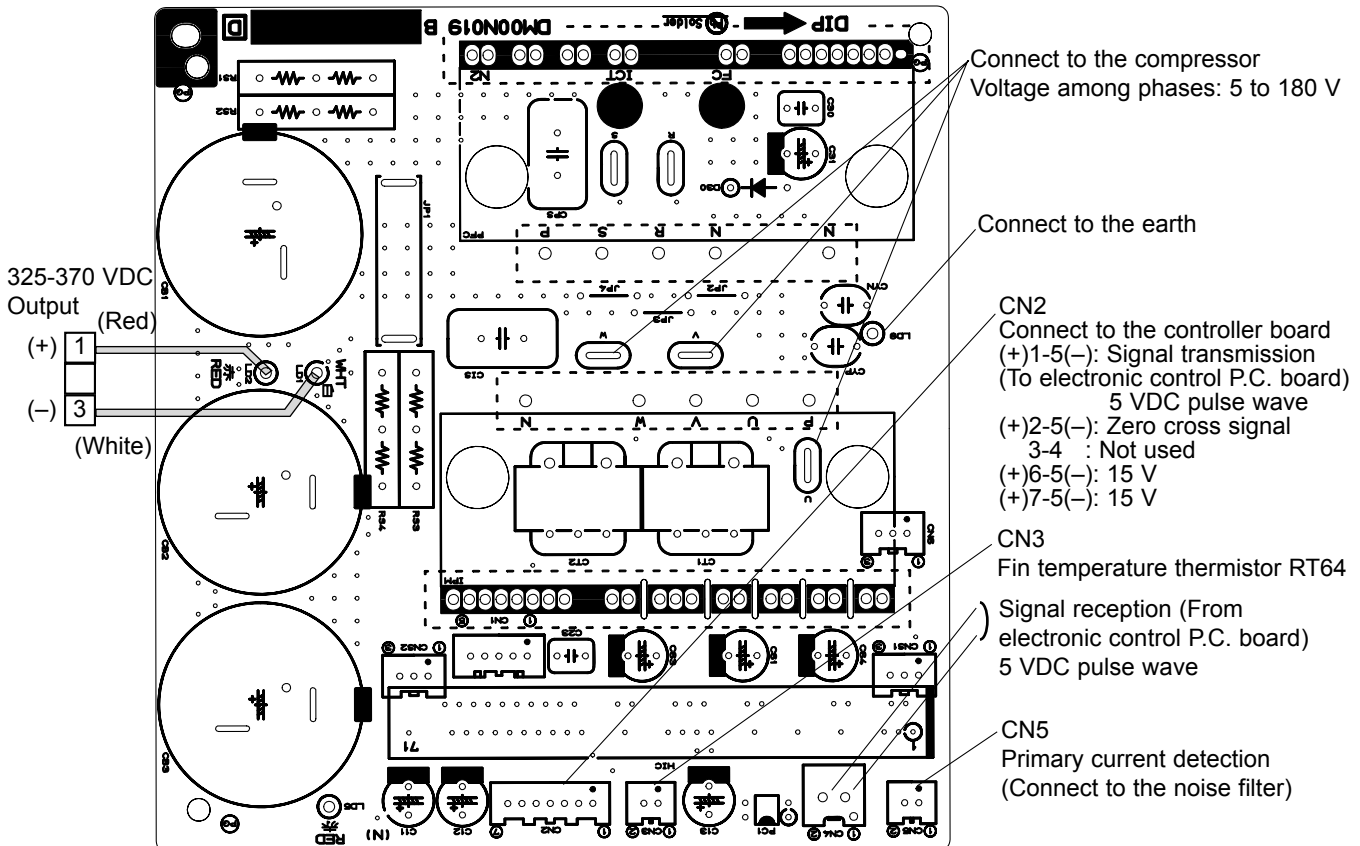

## &lt;"Terminal with locking mechanism" Detaching points&gt;

The terminal which has the locking mechanism can be detached as shown below.  
There are two types (refer to (1) and (2)) of the terminal with locking mechanism.  
The terminal without locking mechanism can be detached by pulling it out.  
Check the shape of the terminal before detaching.

(1) Slide the sleeve and check if there is a locking lever or not.

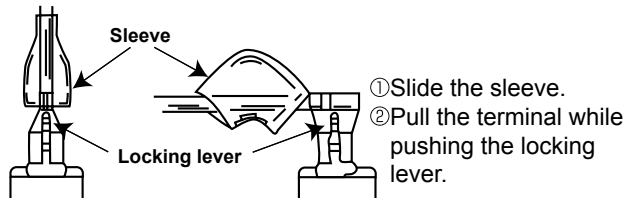

(2) The terminal with this connector has the locking mechanism.

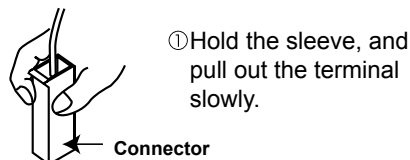

## 12-1. MUZ-FD25VA MUZ-FD25VAH MUZ-FD35VA MUZ-FD35VAH

NOTE: Turn OFF power supply before disassembly.

OPERATING PROCEDURE	PHOTOS
<p><b>1. Removing the cabinet</b></p> <ol style="list-style-type: none"> <li>(1) Remove the screw fixing the service panel.</li> <li>(2) Pull down the service panel and remove it.</li> <li>(3) Disconnect the power supply and indoor/outdoor connecting wire.</li> <li>(4) Remove the screws fixing the top panel.</li> <li>(5) Remove the top panel.</li> <li>(6) Remove the screws fixing the cabinet.</li> <li>(7) Remove the cabinet.</li> <li>(8) Remove the screws fixing the back panel.</li> <li>(9) Remove the back panel.</li> </ol>	<p><b>Photo 1</b></p> <p><b>Photo 2</b></p>

## OPERATING PROCEDURE

### 2. Removing the inverter assembly, inverter P.C. board

- (1) Remove the cabinet and panels. (Refer to 1.)
- (2) Disconnect the lead wire to the reactor and the following connectors:  
<Inverter P.C. board>  
CN721 (R.V. coil)  
CN722 (Defrost heater)  
CN932 (Fan motor)  
CN641 (Defrost thermistor and discharge temperature thermistor)  
CN643 (Ambient temperature thermistor)  
CN644 (Outdoor heat exchanger temperature thermistor)  
CN724 (LEV)
- (3) Remove the compressor connector (CN61).
- (4) Remove the screws fixing the relay panel.
- (5) Remove the inverter assembly.
- (6) Remove the screw of the earth wire and screw of the T.B.support.
- (7) Remove the relay panel from the inverter assembly.
- (8) Remove the inverter P.C. board from the relay panel.

### 3. Removing R.V. coil

- (1) Remove the cabinet and panels. (Refer to 1.)
- (2) Disconnect the following connectors:  
<Inverter P.C. board>  
CN721 (R.V. coil)
- (3) Remove the R.V. coil.

### 4. Removing the discharge temperature thermistor, defrost thermistor, outdoor heat exchanger temperature thermistor and ambient temperature thermistor

- (1) Remove the cabinet and panels. (Refer to 1.)
- (2) Disconnect the lead wire to the reactor and the following connectors:  
<Inverter P.C. board>  
CN641 (Defrost thermistor and discharge temperature thermistor)  
CN643 (Ambient temperature thermistor)  
CN644 (Outdoor heat exchanger temperature thermistor)
- (3) Pull out the discharge temperature thermistor from its holder. (Photo 5)
- (4) Pull out the defrost thermistor from its holder. (Photo 6)
- (5) Pull out the outdoor heat exchanger temperature thermistor from its holder. (Photo 6)
- (6) Pull out the ambient temperature thermistor from its holder.

## PHOTOS

Photo 3

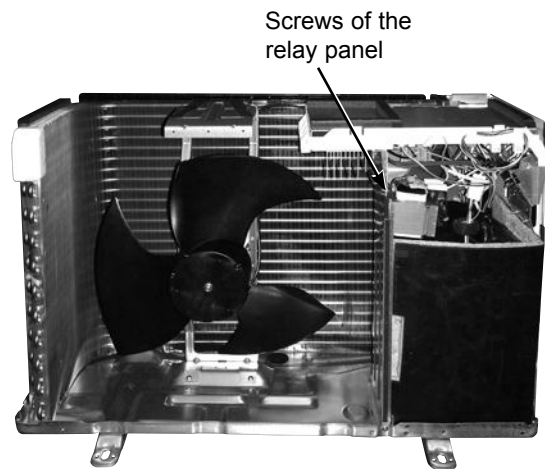

Photo 4 (Inverter assembly)

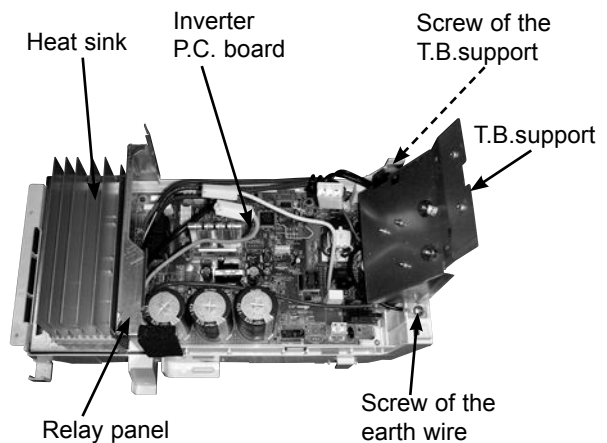

Photo 5



## OPERATING PROCEDURE

### 5. Removing outdoor fan motor

- (1) Remove the cabinet and panels. (Refer to 1.)
- (2) Disconnect the following connectors:  
<Inverter P.C. board>  
CN932 (Fan motor)
- (3) Remove the propeller nut.
- (4) Remove the propeller.
- (5) Remove the screws fixing the fan motor.
- (6) Remove the fan motor.

### 6. Removing the compressor and 4-way valve

- (1) Remove the cabinet and panels. (Refer to 1.)
- (2) Remove the inverter assembly. (Refer to 2.)
- (3) Recover gas from the refrigerant circuit.  
**NOTE:** Recover gas from the pipes until the pressure gauge shows 0 kg/cm<sup>2</sup> (0 MPa).
- (4) Detach the brazed part of the suction and the discharge pipe connected with compressor.
- (5) Remove the nuts of compressor legs.
- (6) Remove the compressor.
- (7) Detach the brazed part of pipes connected with 4-way valve.

## PHOTOS

Photo 6

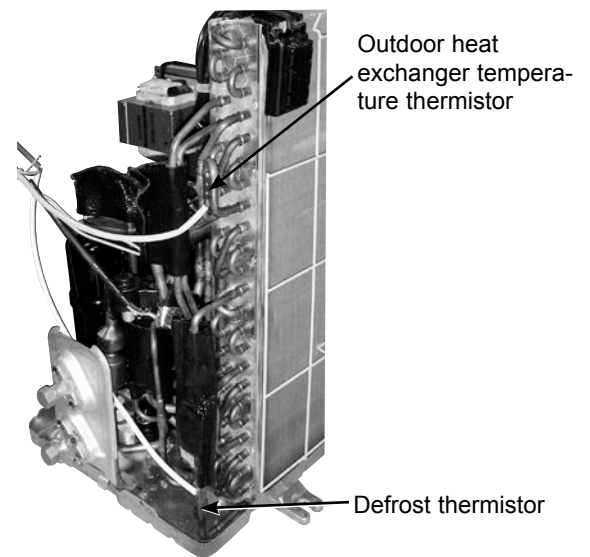

Photo 7

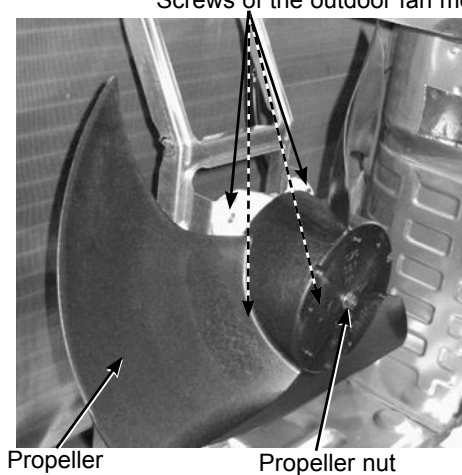
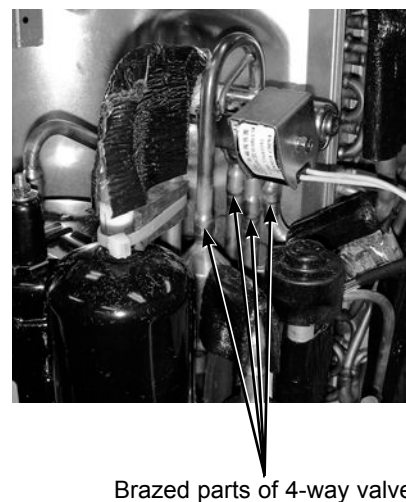
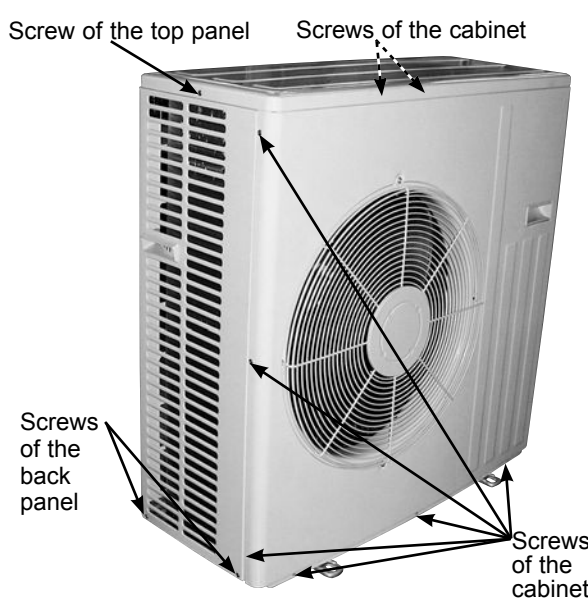
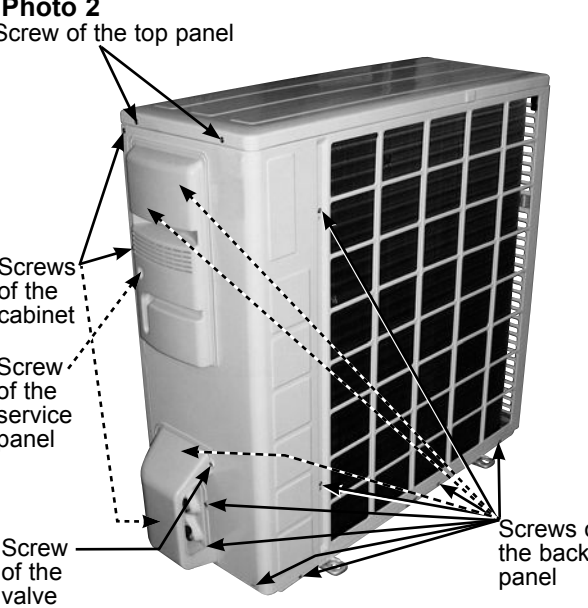

Photo 8



## 12-2. MUZ-FD50VA

**NOTE:** Turn OFF power supply before disassembly.

OPERATING PROCEDURE	PHOTOS
<p><b>1. Removing the cabinet</b></p> <ol style="list-style-type: none"><li>(1) Remove the screws of the service panel.</li><li>(2) Remove the screws of the top panel.</li><li>(3) Remove the screw of the valve cover.</li><li>(4) Remove the service panel.</li><li>(5) Remove the top panel.</li><li>(6) Remove the valve cover.</li><li>(7) Disconnect the power supply and indoor/outdoor connecting wire.</li><li>(8) Remove the screws of the cabinet.</li><li>(9) Remove the cabinet.</li><li>(10) Remove the screws of the back panel.</li><li>(11) Remove the back panel.</li></ol>	<p><b>Photo 1</b></p>  <p>Screw of the top panel    Screws of the cabinet</p> <p>Screws of the back panel    Screws of the cabinet</p> <p><b>Photo 2</b></p>  <p>Screw of the top panel</p> <p>Screws of the cabinet</p> <p>Screw of the service panel</p> <p>Screw of the valve cover</p> <p>Screws of the back panel</p>

## OPERATING PROCEDURE

### 2. Removing the inverter assembly, outdoor electric control P.C. board, power board, noise filter P.C. board and reactor.

- (1) Remove the top panel, cabinet and service panel. (Refer to 1.)
- (2) Remove the back panel. (Refer to 1.)
- (3) Disconnect the following connectors:  
<Electronic control P.C. board>  
CN931 and CN932 (Fan motor)  
CN795 (LEV)  
CN661 (Discharge temperature thermistor, defrost thermistor and outdoor heat exchanger temperature thermistor)  
CN663 (Ambient temperature thermistor)  
<Noise filter P.C. board>  
CN912 (R.V. coil)
- (4) Remove the compressor connector.
- (5) Remove the screws fixing the relay panel.
- (6) Remove the inverter assembly.
- (7) Disconnect all connectors and lead wires on the electronic control P.C. board.
- (8) Remove the outdoor electronic control P.C. board from the inverter assembly.
- (9) Disconnect the reactor lead wire.
- (10) Remove the screws of the reactor, and remove the reactor.
- (11) Remove the screws fixing the power board assembly.
- (12) Disconnect all connectors and lead wires on the power board.
- (13) Remove the power board from the inverter assembly.
- (14) Disconnect all connectors and lead wires on the noise filter P.C. board.
- (15) Remove the noise filter P.C. board from the inverter assembly.

## PHOTOS

Photo 3 (Inverter assembly)

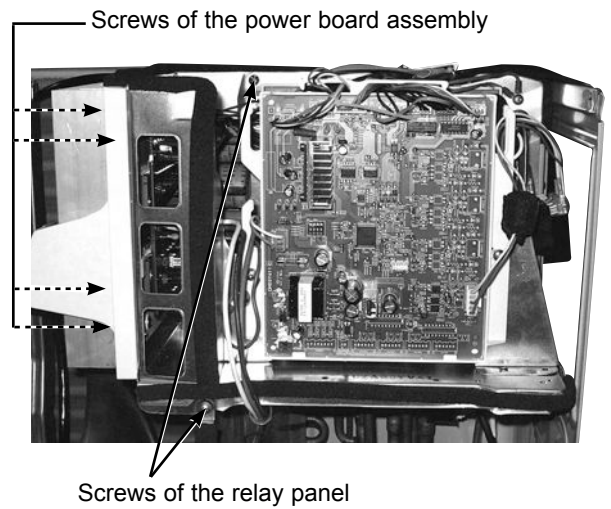
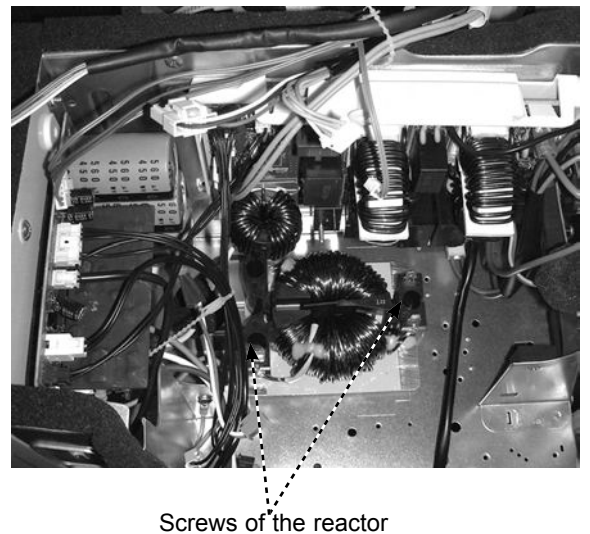

Photo 4



## OPERATING PROCEDURE

### 3. Removing the defrost thermistor, discharge temperature thermistor, outdoor heat exchanger temperature thermistor and ambient temperature thermistor

- (1) Remove the top panel, cabinet and service panel. (Refer to 1.)
- (2) Remove the back panel. (Refer to 1.)
- (3) Disconnect the following connectors:  
<Electronic control P.C. board>  
CN661 (Discharge temperature thermistor, defrost thermistor and outdoor heat exchanger temperature thermistor)  
CN663 (Ambient temperature thermistor)
- (4) Pull out the defrost thermistor from its holder.
- (5) Pull out the discharge temperature thermistor from its holder. (Photo 7)
- (6) Pull out the outdoor heat exchanger temperature thermistor from its holder.
- (7) Pull out the ambient temperature thermistor from its holder.

### 4. Removing outdoor fan motor

- (1) Remove the top panel, cabinet and service panel. (Refer to 1.)
- (2) Disconnect the following connectors:  
<Electronic control P.C. board>  
CN931 and CN932 (Fan motor)
- (3) Remove the propeller.
- (4) Remove the screws fixing the fan motor.
- (5) Remove the fan motor.

## PHOTOS

Photo 5

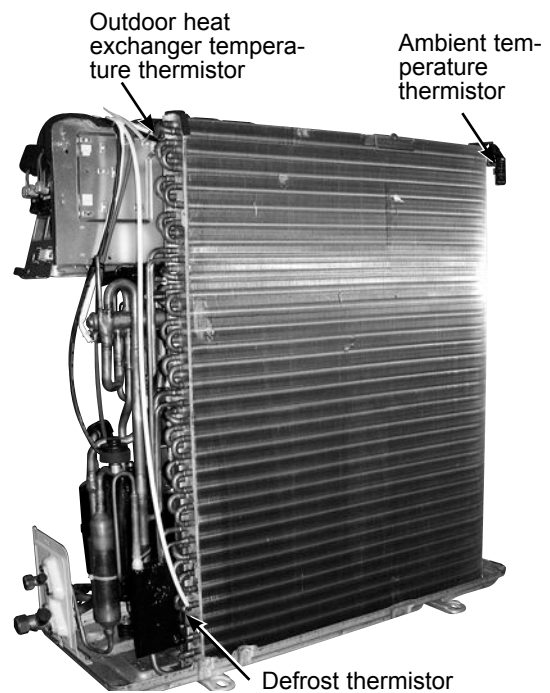
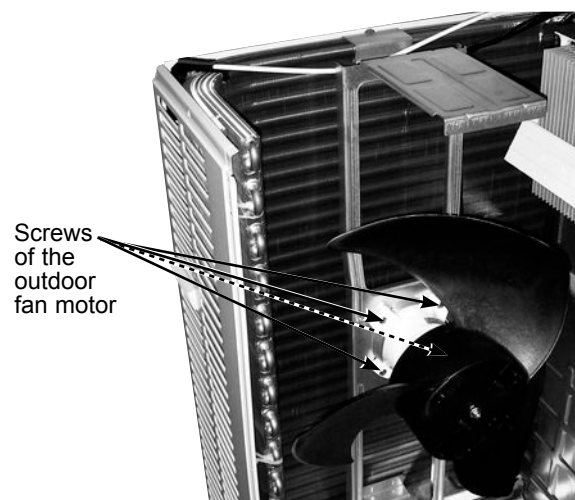

Photo 6





**OPERATING PROCEDURE**

**5. Removing the compressor and 4-way valve**

- (1) Remove the top panel, cabinet and service panel. (Refer to 1.)
- (2) Remove the back panel. (Refer to 1.)
- (3) Remove the inverter assembly. (Refer to 2.)
- (4) Recover gas from the refrigerant circuit.

**NOTE:** Recover gas from the pipes until the pressure gauge shows 0 MPa.

- (5) Detach the brazed part of the suction and the discharge pipe connected with compressor.
- (6) Remove the compressor nuts.
- (7) Remove the compressor.
- (8) Detach the brazed part of 4-way valve and pipe.

**6. Removing R.V. coil**

- (1) Remove the top panel, cabinet and service panel. (Refer to 1.)
- (2) Remove the back panel. (Refer to 1.)
- (3) Disconnect the following connectors:  
<Noise filter P.C. board>  
CN912 (R.V. coil)
- (4) Remove the R.V. coil.

**PHOTOS**

**Photo 7**

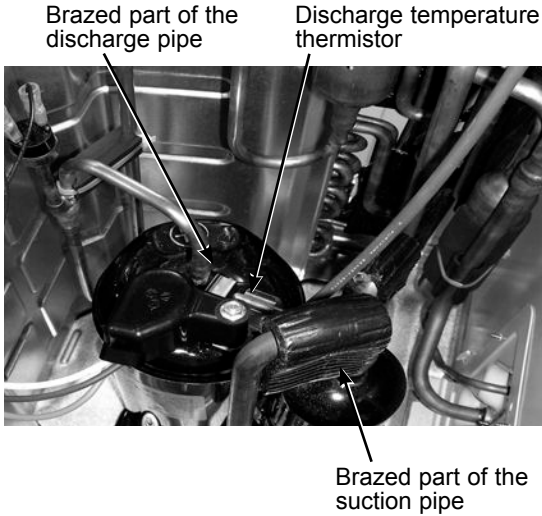

**Photo 8**

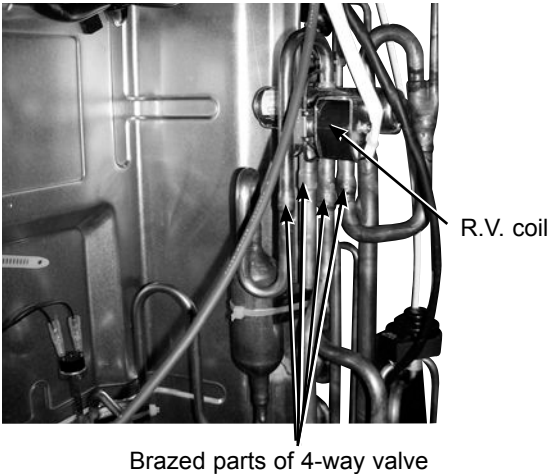



HEAD OFFICE: TOKYO BLDG., 2-7-3, MARUNOUCHI, CHIYODA-KU, TOKYO 100-8310, JAPAN

© Copyright 2007 MITSUBISHI ELECTRIC CO.,LTD  
Distributed in Jul. 2011. No. OBH489 REVISED EDITION-C  
Distributed in Nov. 2008. No. OBH489 REVISED EDITION-B 5  
Distributed in Oct. 2007. No. OBH489 REVISED EDITION-A 6  
Distributed in Aug. 2007. No. OBH489 6  
Made in Japan

New publication, effective Jul. 2011  
Specifications subject to change without notice.