

Revision A:

- "TROUBLESHOOTING" has been corrected.
- "Specifications and rating conditions of main electric parts" has been corrected.

Please void OBH590.

OUTDOOR UNIT SERVICE MANUAL



No. OBH590
REVISED EDITION-A

Models

- MUZ-EF25VE** - E1
- MUZ-EF25VEH** - E1
- MUZ-EF35VE** - E1
- MUZ-EF35VEH** - E1
- MUZ-EF42VE** - E1
- MUZ-EF50VE** - E1

Indoor unit service manual
MSZ-EF•VE Series (OBH589)

MUZ-EF25VE MUZ-EF25VEH
MUZ-EF35VE MUZ-EF35VEH
MUZ-EF42VE

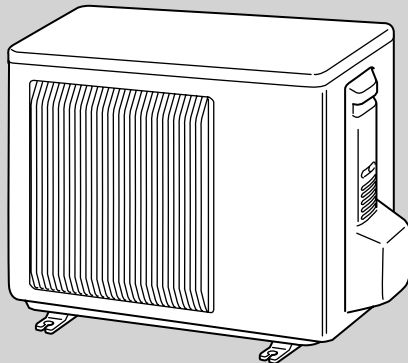

CONTENTS

1. TECHNICAL CHANGES	3
2. PART NAMES AND FUNCTIONS	4
3. SPECIFICATION	5
4. NOISE CRITERIA CURVES	6
5. OUTLINES AND DIMENSIONS	8
6. WIRING DIAGRAM	9
7. REFRIGERANT SYSTEM DIAGRAM	11
8. PERFORMANCE CURVES	13
9. ACTUATOR CONTROL	27
10. SERVICE FUNCTIONS	28
11. TROUBLESHOOTING	28
12. DISASSEMBLY INSTRUCTIONS	45

PARTS CATALOG (OBB590)

NOTE:

RoHS compliant products have <G> mark on the spec name plate.



Use the specified refrigerant only

Never use any refrigerant other than that specified.

Doing so may cause a burst, an explosion, or fire when the unit is being used, serviced, or disposed of.

Correct refrigerant is specified in the manuals and on the spec labels provided with our products.

We will not be held responsible for mechanical failure, system malfunction, unit breakdown or accidents caused by failure to follow the instructions.

<Preparation before the repair service>

- Prepare the proper tools.
- Prepare the proper protectors.
- Provide adequate ventilation.
- After stopping the operation of the air conditioner, turn off the power-supply breaker and remove the power plug.
- Discharge the capacitor before the work involving the electric parts.

<Precautions during the repair service>

- Do not perform the work involving the electric parts with wet hands.
- Do not pour water into the electric parts.
- Do not touch the refrigerant.
- Do not touch the hot or cold areas in the refrigeration cycle.
- When the repair or the inspection of the circuit needs to be done without turning off the power, exercise great caution not to touch the live parts.

Revision A:

- "TROUBLESHOOTING" has been corrected (11-2,11-5).
- "Specifications and rating conditions of main electric parts" has been corrected. (3)

1

TECHNICAL CHANGES

MUZ-EF25VE -E1

MUZ-EF25VEH -E1

MUZ-EF35VE -E1

MUZ-EF35VEH -E1

MUZ-EF42VE -E1

MUZ-EF50VE -E1

1. New model

2

PART NAMES AND FUNCTIONS

MUZ-EF25VE MUZ-EF25VEH
 MUZ-EF35VE MUZ-EF35VEH
 MUZ-EF42VE



MUZ-EF50VE

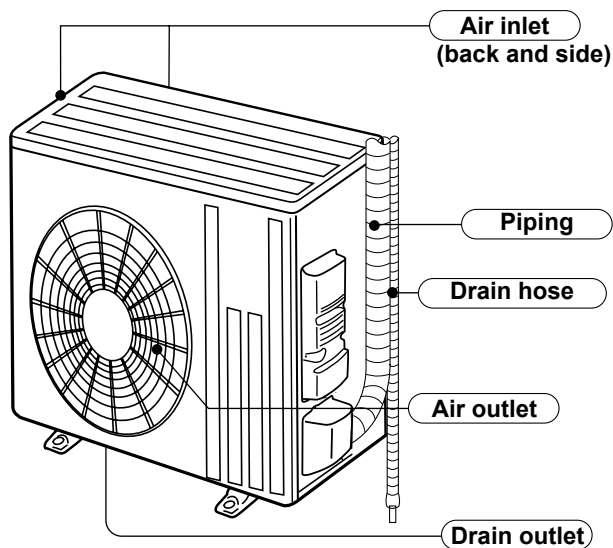

ACCESSORIES

<p>MODELS</p>	<p>MUZ-EF25VE MUZ-EF35VE MUZ-EF42VE MUZ-EF50VE</p>
<p>Drain socket</p>	<p>1</p>

3

SPECIFICATION

Outdoor model			MUZ-EF25VE MUZ-EF25VEH	MUZ-EF35VE MUZ-EF35VEH	MUZ-EF42VE	MUZ-EF50VE		
Power supply			Single phase, 230 V, 50 Hz					
Capacity Rated frequency (Min.-Max.)	Cooling	kW	2.5 (1.2 - 3.4)	3.5 (1.4 - 4.0)	4.2 (0.9 - 4.6)	5.0 (1.4 - 5.4)		
	Heating		3.2 (1.1 - 4.2)	4.0 (1.8 - 5.5)	5.4 (1.4 - 6.3)	5.8 (1.6 - 7.5)		
Breaker Capacity		A	10			16		
Electrical data	Power input *1 (Total)	Cooling	545	910	1,280	1,560		
		Heating	700	955	1,460	1,565		
	Running current *1 (Total)	Cooling	2.9	4.2	5.7	6.9		
		Heating	3.5	4.4	6.5	7.0		
	Power factor *1 (Total)	Cooling	81	94	97	98		
		Heating	86	94	97	97		
Starting current *1 (Total)		A	3.5	4.4	6.5	7.0		
Coefficient of performance (COP) *1 (Total)		Cooling	4.59	3.85	3.28	3.21		
		Heating	4.57	4.19	3.70	3.71		
Model			KNB073FKFMC	KNB092FFAMC	SNB130FGAMT	SNB130FGBMT		
Output		W	550	650	900			
Current *1		Cooling	2.76	4.06	5.56	5.58		
		Heating	3.24	4.09	6.19	5.75		
Refrigeration oil (Model)		L	0.31 (FV50S)	0.27(FV50S)	0.35 (FV50S)			
Model			RC0J50-FA			RC0J60-BD		
Current *1		Cooling	0.24	0.29	0.30	0.84		
		Heating	0.27	0.28	0.28	0.93		
Dimensions W × H × D		mm	800 × 550 × 285			840 × 880 × 330		
Weight		kg	30	35		54		
Special remarks	Dehumidification		Cooling	ℓ/h	0.3	1.0	1.7	2.1
	Air flow *1		Cooling	High	1,806			2,868
				Low	1,170	1,038		1,602
	Heating		High	2,106	2,016		2,778	
			Med.	1,806	1,770		2,778	
			Low	1,452	1,326		2,124	
	Sound level *1		Cooling	47	49	50	52	
			Heating	48	50	51	52	
	Fan speed		Cooling	High	740		810	840
				Low	740		490	480
			Heating	High	860	900		810
				Med.	740	770		810
				Low	600	610		620
	Fan speed regulator			3				
Refrigerant filling capacity (R410A)		kg	0.80	1.15		1.45		

NOTE: Test conditions are based on ISO 5151.

Cooling: Indoor Dry-bulb temperature 27°C

Wet-bulb temperature 19°C

Outdoor Dry-bulb temperature 35°C

Heating: Indoor Dry-bulb temperature 20°C

Wet-bulb temperature 6°C

Outdoor Dry-bulb temperature 7°C

Refrigerant piping length (one way): 5 m

*1 Measured under rated operating frequency.

Specifications and rating conditions of main electric parts

Item	Model	MUZ-EF25VE	MUZ-EF25VEH	MUZ-EF35VE	MUZ-EF35VEH	MUZ-EF42VE	MUZ-EF50VE
Smoothing capacitor	(C61, C62, C63)	620 μ F 420 V					
Diode module	(DB61)	15 A 600 V					25 A 600 V
Fuse	(F61)	T20AL250V					
	(F701, F801, F901)	T3.15AL250V					
Defrost heater	(H)	—	230 V 130 W	—	230 V 130 W	—	—
Intelligent power module	(IC700)	15 A 600 V				20 A 600 V	
	(IC932)	8A600V					
Expansion valve coil	(LEV)	12 V DC					
Reactor	(L61)	18 mH			23 mH		
Power factor controller	(IC820)	20A 600V					
Current-limiting PTC thermistor	(PTC64, PTC65)	33 Ω					
Terminal block	(TB)	5 P					
Relay	(X63)	3 A 250 V					
	(X64)	20 A 250 V					
	(X66)	—	3 A 250 V	—	3 A 250 V		
	(X69)	10A 230V					
R.V.coil	(21S4)	220 - 240 V AC					
Heater protector	(26H)	—	Open 45°C	—	Open 45°C	—	—

4 NOISE CRITERIA CURVES

MUZ-EF25VE MUZ-EF25VEH

FUNCTION	SPL(dB(A))	LINE
COOLING	47	●—●
HEATING	48	○—○

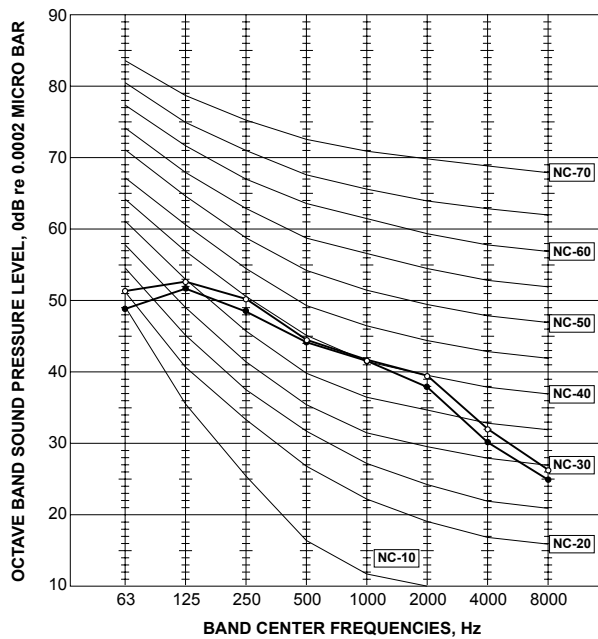

MUZ-EF35VE MUZ-EF35VEH

FUNCTION	SPL(dB(A))	LINE
COOLING	49	●—●
HEATING	50	○—○

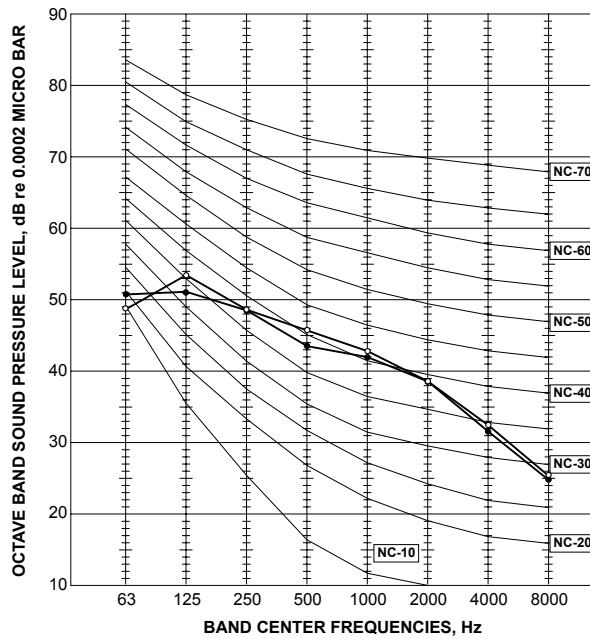

MUZ-EF42VE

FUNCTION	SPL(dB(A))	LINE
COOLING	50	●—●
HEATING	51	○—○

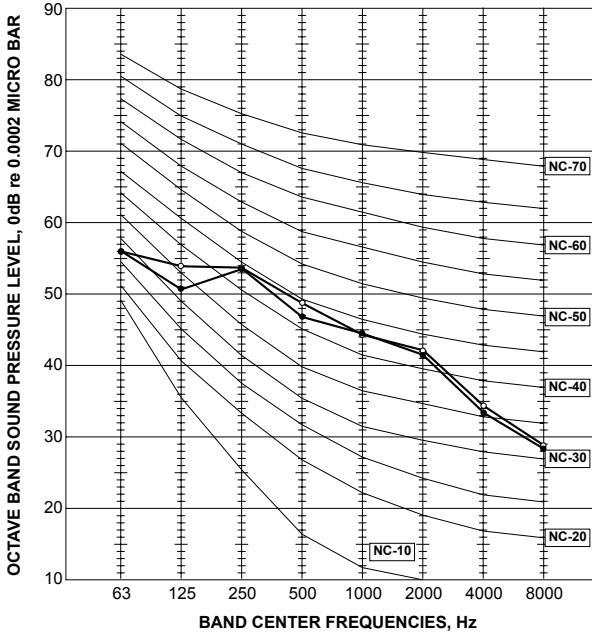

MUZ-EF50VE

FUNCTION	SPL(dB(A))	LINE
COOLING	52	●—●
HEATING	52	○—○

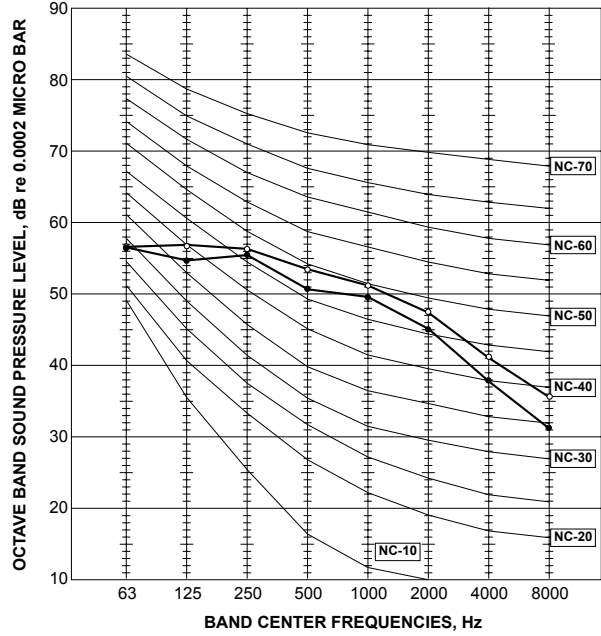

Test conditions

Cooling: Dry-bulb temperature 35°C

Heating: Dry-bulb temperature 7°C Wet-bulb temperature 6°C

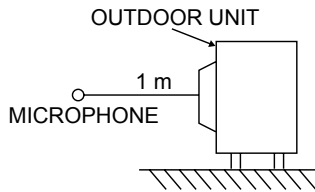

5

OUTLINES AND DIMENSIONS

MUZ-EF25VE MUZ-EF25VEH MUZ-EF35VE MUZ-EF35VEH MUZ-EF42VE

Unit: mm

REQUIRED SPACE

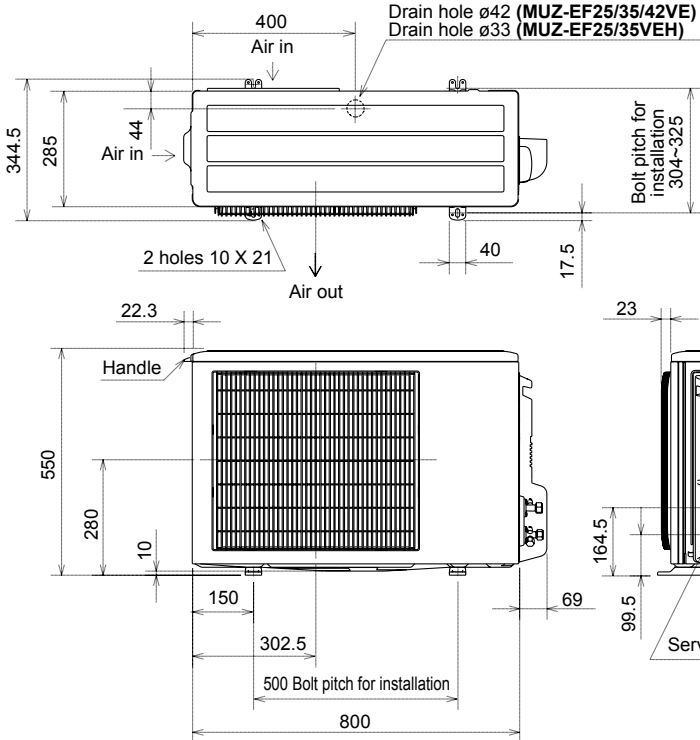
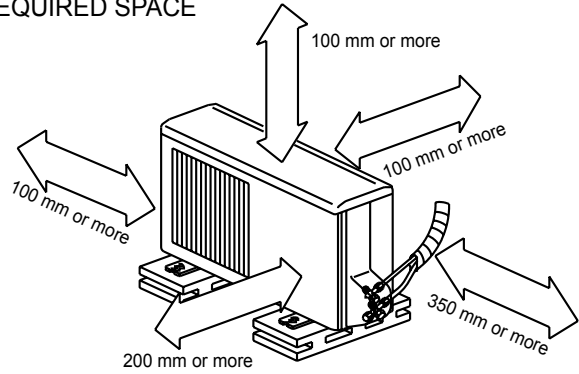

MUZ-EF50VE

REQUIRED SPACE

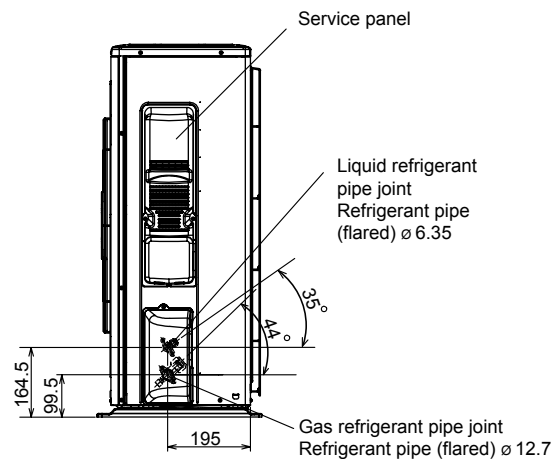
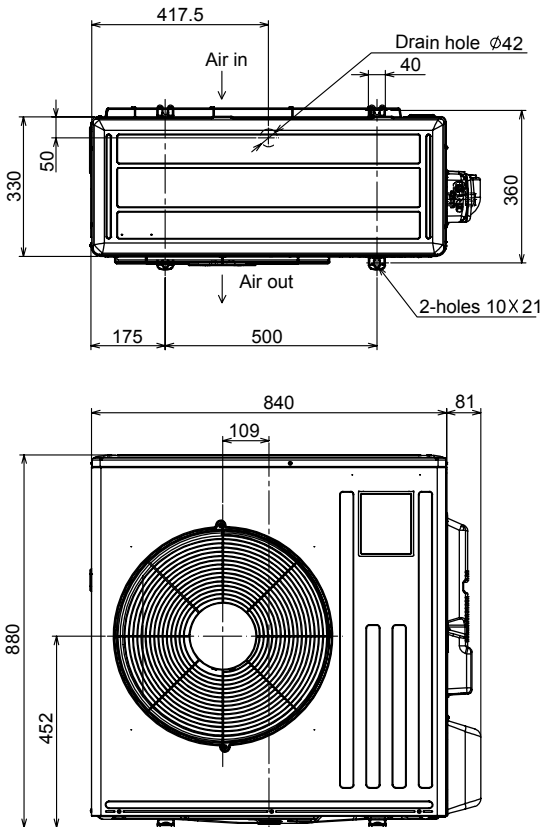
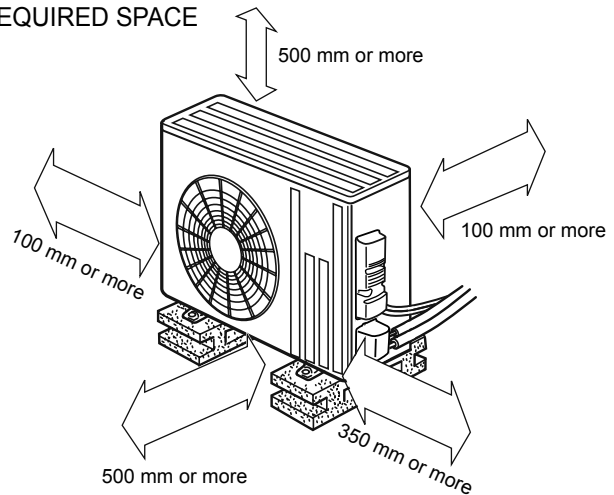

6

WIRING DIAGRAM

MUZ-EF25VE MUZ-EF35VE

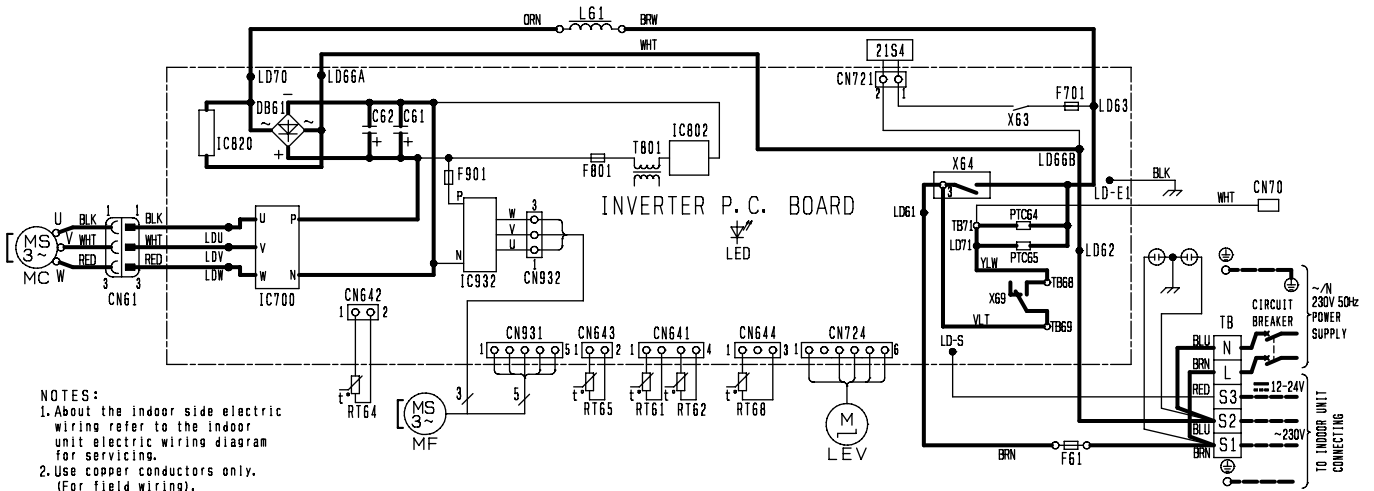

SYMBOL	NAME	SYMBOL	NAME	SYMBOL	NAME
CN70	CONNECTOR	LEV	EXPANSION VALVE COIL	RT65	AMBIENT TEMP. THERMISTOR
C61, C62	SMOOTHING CAPACITOR	L61	REACTOR	RT68	OUTDOOR HEAT EXCHANGER TEMP. THERMISTOR.
DB61	DIODE MODULE	MC	COMPRESSOR	TB	TERMINAL BLOCK
F61	FUSE (T20AL250V)	MF	FAN MOTOR	T801	TRANSFORMER
F701, F801, F901	FUSE (T3.15AL250V)	PTC64, PTC65	CIRCUIT PROTECTION	X63, X64, X69	RELAY
IC700, IC820, IC932	POWER MODULE	RT61	DEFROST THERMISTOR	2154	REVERSING VALVE COIL
IC802	POWER DEVICE	RT62	DISCHARGE TEMP. THERMISTOR		
LED	LED	RT64	FIN TEMP. THERMISTOR		

MUZ-EF25VEH MUZ-EF35VEH

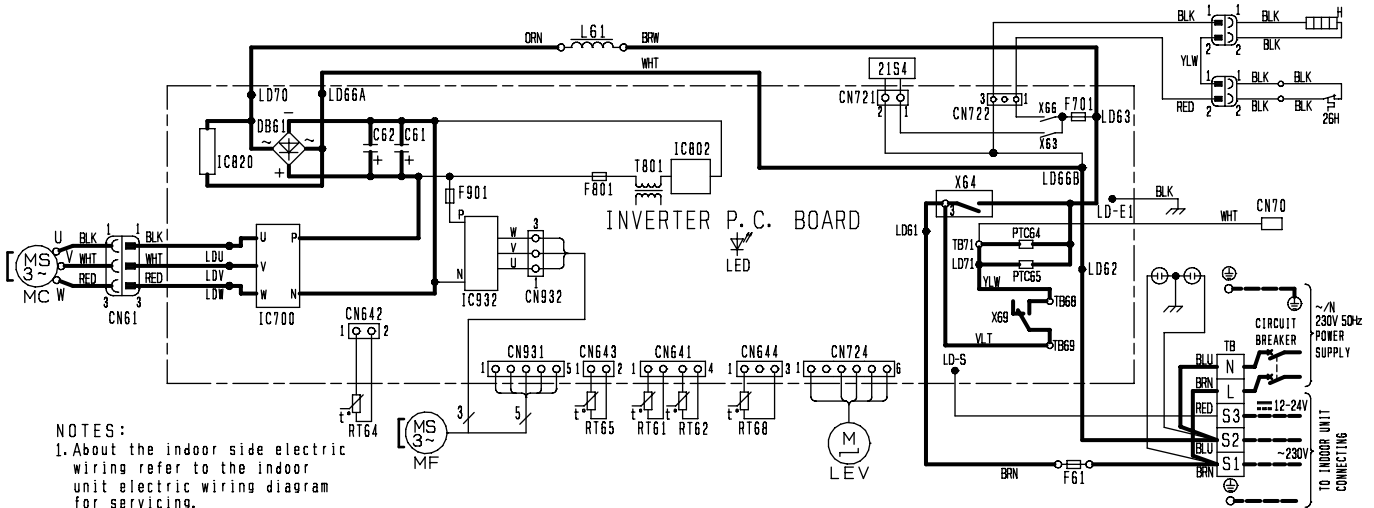

SYMBOL	NAME	SYMBOL	NAME	SYMBOL	NAME
CN70	CONNECTOR	LEV	EXPANSION VALVE COIL	RT68	OUTDOOR HEAT EXCHANGER TEMP. THERMISTOR.
C61, C62	SMOOTHING CAPACITOR	L61	REACTOR	TB	TERMINAL BLOCK
DB61	DIODE MODULE	MC	COMPRESSOR	T801	TRANSFORMER
F61	FUSE (T20AL250V)	MF	FAN MOTOR	X63, X64, X66, X69	RELAY
F701, F801, F901	FUSE (T3.15AL250V)	PTC64, PTC65	CIRCUIT PROTECTION	2154	REVERSING VALVE COIL
IC700, IC820, IC932	POWER MODULE	RT61	DEFROST THERMISTOR	26H	HEATER PROTECTOR
IC802	POWER DEVICE	RT62	DISCHARGE TEMP. THERMISTOR		
LED	LED	RT65	AMBIENT TEMP. THERMISTOR		

MUZ-EF42VE MUZ-EF50VE

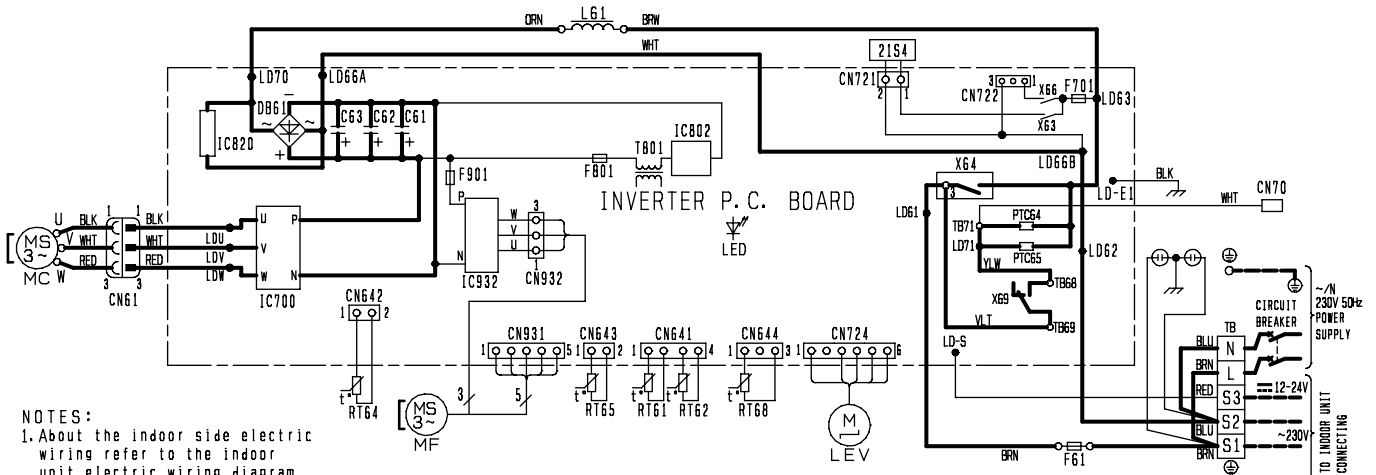

- NOTES:
- About the indoor side electric wiring refer to the indoor unit electric wiring diagram for servicing.
 - Use copper conductors only. (For field wiring).

SYMBOL	NAME	SYMBOL	NAME	SYMBOL	NAME
CN70	CONNECTOR	LEV	EXPANSION VALVE COIL	RT65	AMBIENT TEMP. THERMISTOR
C61, C62, C63	SMOOTHING CAPACITOR	L61	REACTOR	RT68	OUTDOOR HEAT EXCHANGER TEMP. THERMISTOR.
DB61	DIODE MODULE	MC	COMPRESSOR	TB	TERMINAL BLOCK
F61	FUSE (T20AL 250V)	MF	FAN MOTOR	T801	TRANSFORMER
F701, F801, F901	FUSE (T3, 15AL 250V)	PTC64, PTC65	CIRCUIT PROTECTION	X63, X64, X66, X69	RELAY
IC700, IC820, IC932	POWER MODULE	RT61	DEFROST THERMISTOR		
IC802	POWER DEVICE	RT62	DISCHARGE TEMP. THERMISTOR		
LED	LED	RT64	FIN TEMP. THERMISTOR		

7

REFRIGERANT SYSTEM DIAGRAM

MUZ-EF25VE MUZ-EF25VEH

Unit: mm

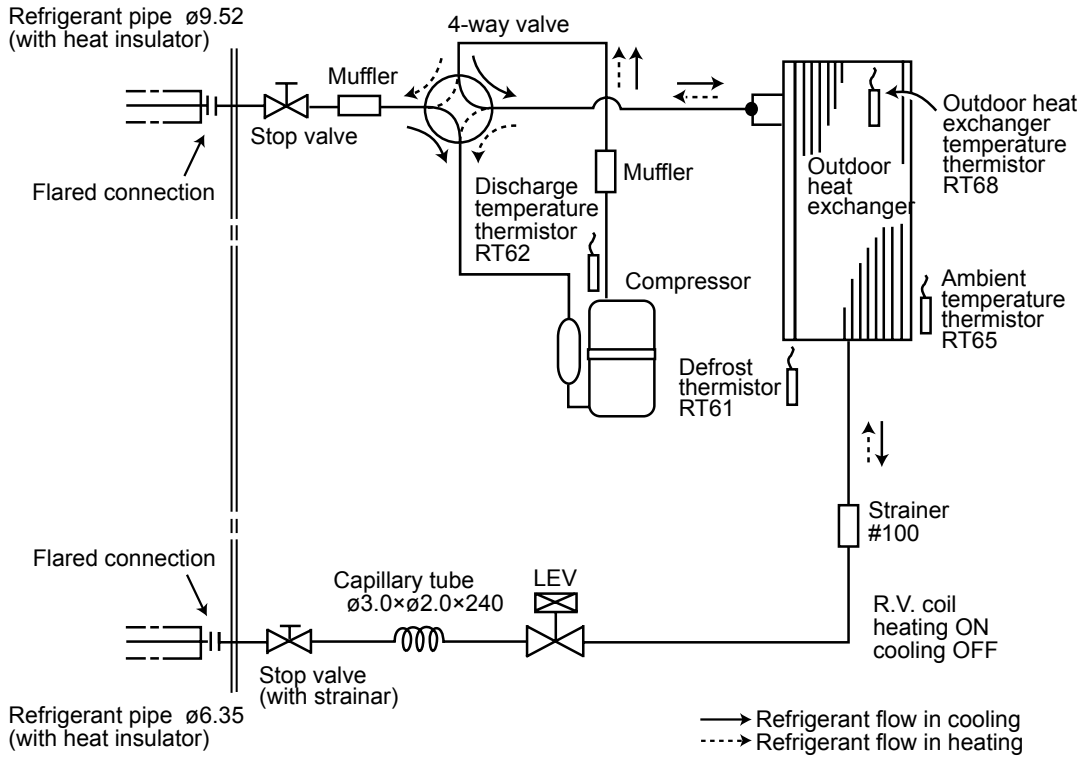

MUZ-EF35VE MUZ-EF35VEH MUZ-EF42VE

Unit: mm

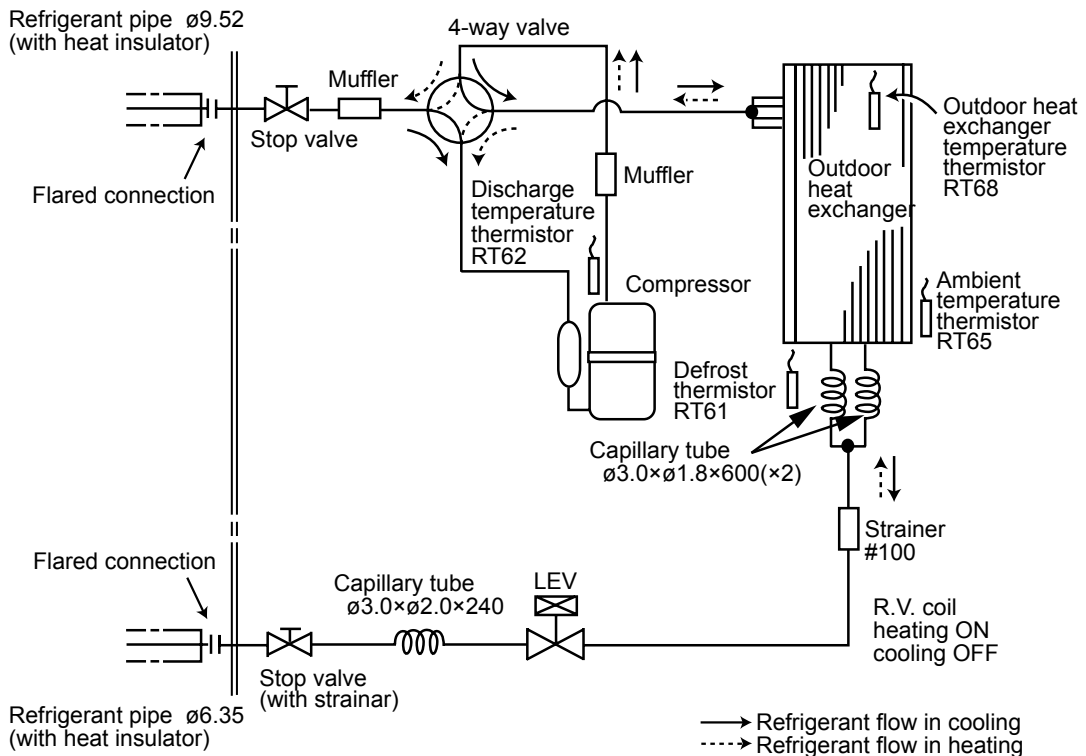

MUZ-EF50VE

Unit: mm

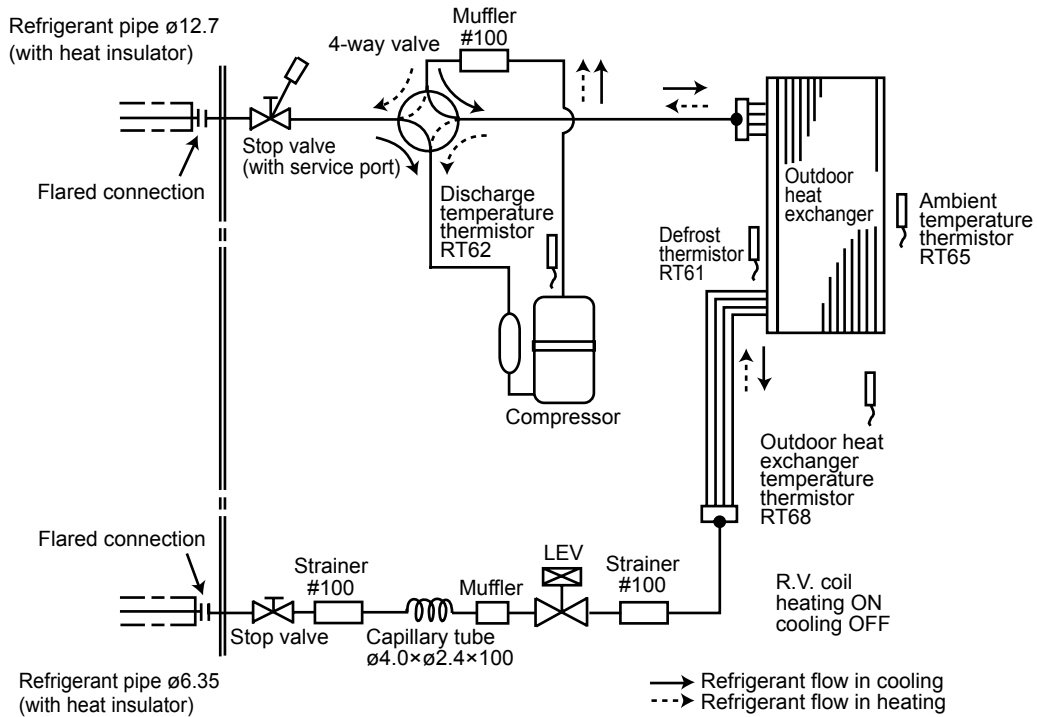

MAX. REFRIGERANT PIPING LENGTH and MAX. HEIGHT DIFEFRENCE

	Refrigerant piping: m		Piping size O.D: mm	
	Max. Length A	Max. Height difference B	Gas	Liquid
MUZ-EF25/35/42	20	12	9.52	6.35
MUZ-EF50	30	15	12.7	

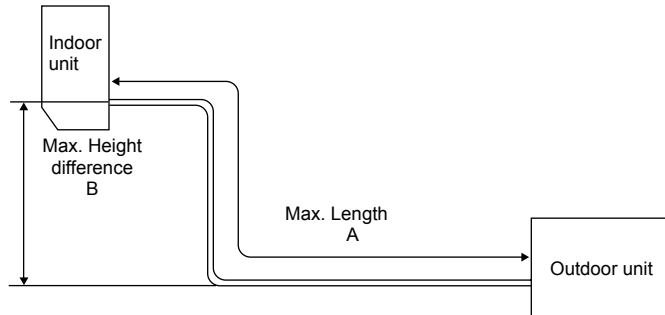

ADDITIONAL REFRIGERANT CHARGE (R410A: g)

Model	Outdoor unit precharged	Refrigerant piping length (one way)									
		7 m	8 m	9 m	10 m	11 m	12 m	13 m	14 m	15 m	20 m
MUZ-EF25	800	0	30	60	90	120	150	180	210	240	390
MUZ-EF35/42	1,150	0	30	60	90	120	150	180	210	240	390

Calculation: $X \text{ g} = 30 \text{ g/m} \times (\text{Refrigerant piping length (m)} - 7)$

Model	Outdoor unit precharged	Refrigerant piping length (one way)					
		7 m	10 m	15 m	20 m	25 m	30 m
MUZ-EF50	1,450	0	60	160	260	360	460

Calculation: $X \text{ g} = 20 \text{ g/m} \times (\text{Refrigerant piping length (m)} - 7)$

NOTE: Refrigerant piping exceeding 7 m requires additional refrigerant charge according to the calculation.

6.1	9.0	11.5	13.1
5.6	8.2	10.5	11.8
5.1	7.4	9.4	10.6
4.6	6.7	8.4	9.5
4.1	5.9	7.4	8.4
3.6	5.2	6.5	7.3
MUZ-EF25VE MUZ-EF25VEH	MUZ-EF35VE MUZ-EF35VEH	MUZ-EF42VE	MUZ-EF50VE

Total input (Cooling : at Rated frequency)

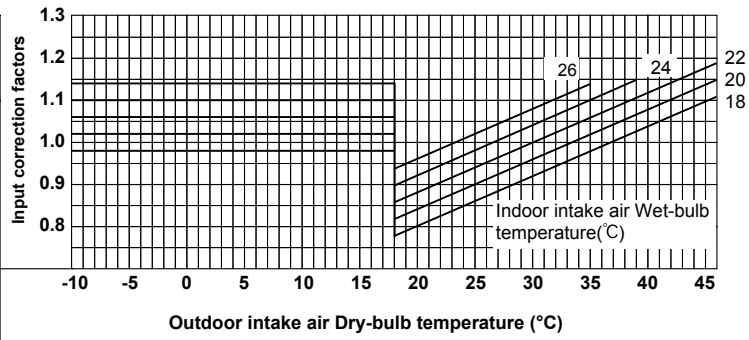

17.6	20.6	27.8	28.7
16.2	19.0	25.7	26.5
14.9	17.4	23.5	24.3
13.5	15.8	21.4	22.1
12.2	14.3	19.2	19.9
10.8	12.7	17.1	17.7
9.5	11.1	15.0	15.5
8.1	9.5	12.8	13.3
6.8	7.9	10.7	11.1
5.4	6.3	8.6	8.8
MUZ-EF25VE MUZ-EF25VEH	MUZ-EF35VE MUZ-EF35VEH	MUZ-EF42VE	MUZ-EF50VE

Heating capacity (at Rated frequency)

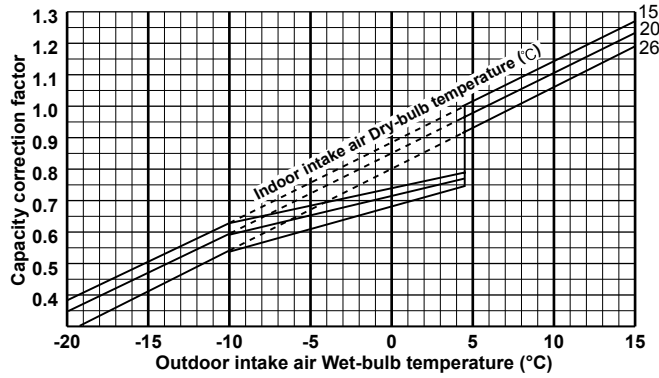

17.6	20.6	27.8	28.7
16.2	19.0	25.7	26.5
14.9	17.4	23.5	24.3
13.5	15.8	21.4	22.1
12.2	14.3	19.2	19.9
10.8	12.7	17.1	17.7
9.5	11.1	15.0	15.5
8.1	9.5	12.8	13.3
6.8	7.9	10.7	11.1
5.4	6.3	8.6	8.8
MUZ-EF25VE MUZ-EF35VEH	MUZ-EF35VE MUZ-EF35VEH	MUZ-EF42VE	MUZ-EF50VE

Total input (Heating : at Rated frequency)

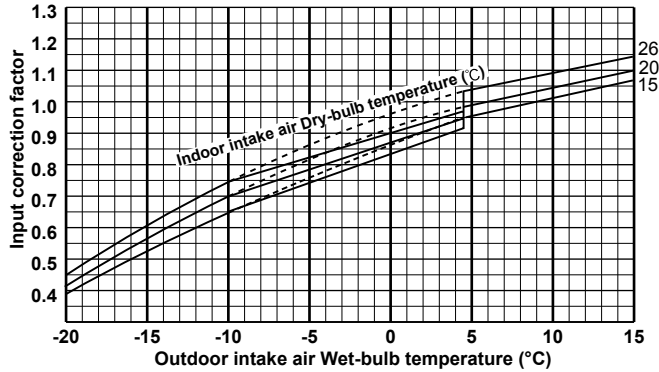

Lower limit of guaranteed operating range in heating
MUZ-EF25/35/42/50VE: -15°C
MUZ-EF25/35VEH : -20°C

NOTE: The above broken lines are for the heating operation without any frost and defrost operation.

8-2. CAPACITY AND INPUT CORRECTION BY OPERATIONAL FREQUENCY OF COMPRESSOR

MUZ-EF25VE MUZ-EF25VEH

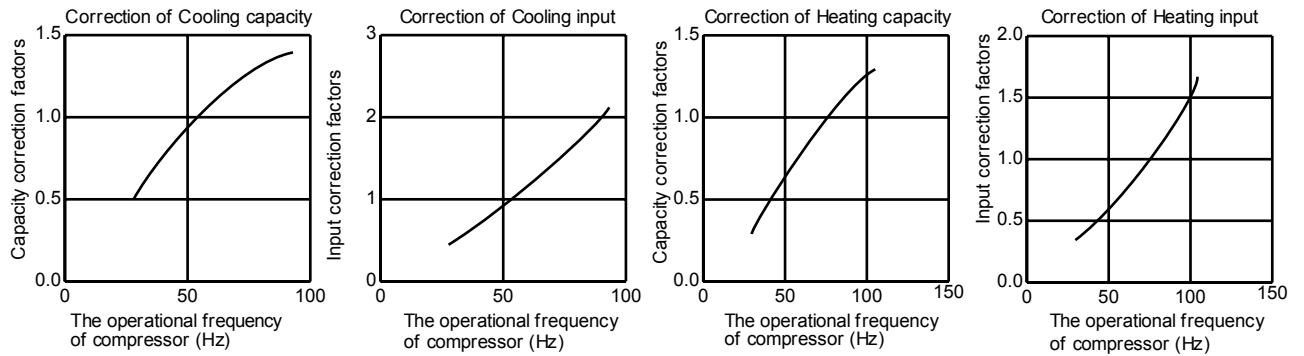

MUZ-EF35VE MUZ-EF35VEH

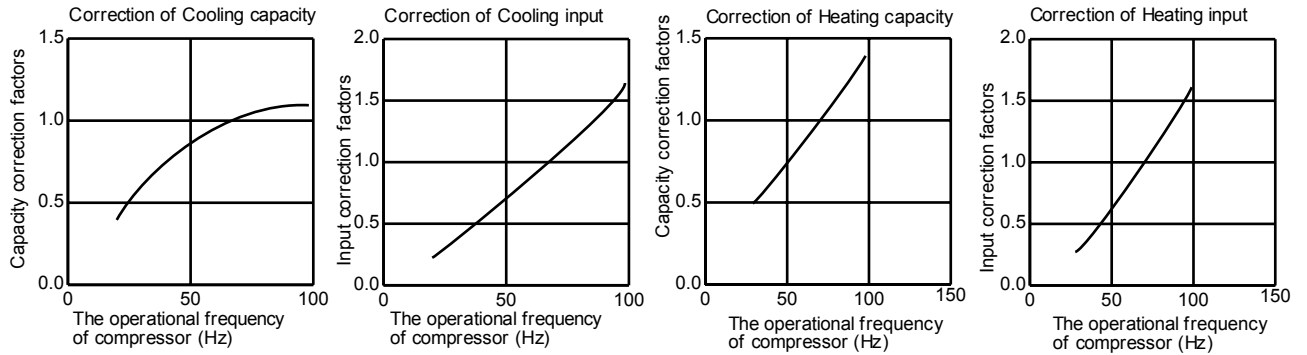

MUZ-EF42VE

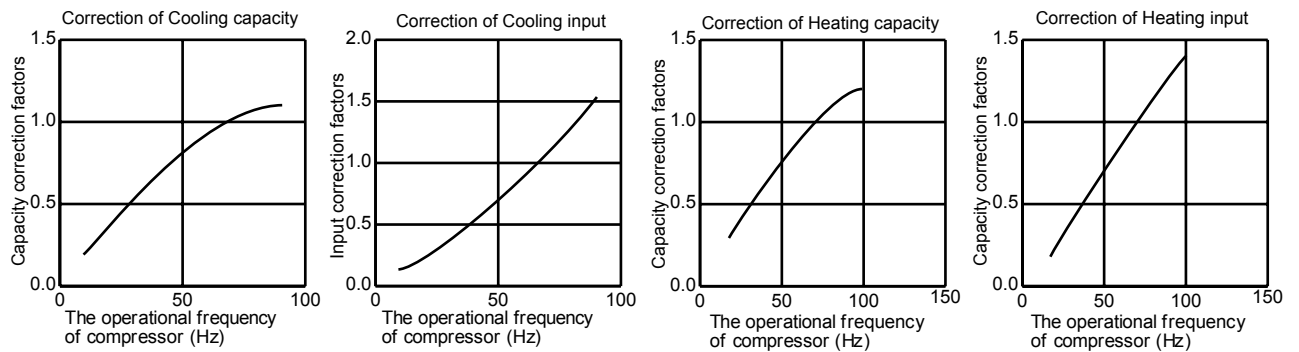

MUZ-EF50VE

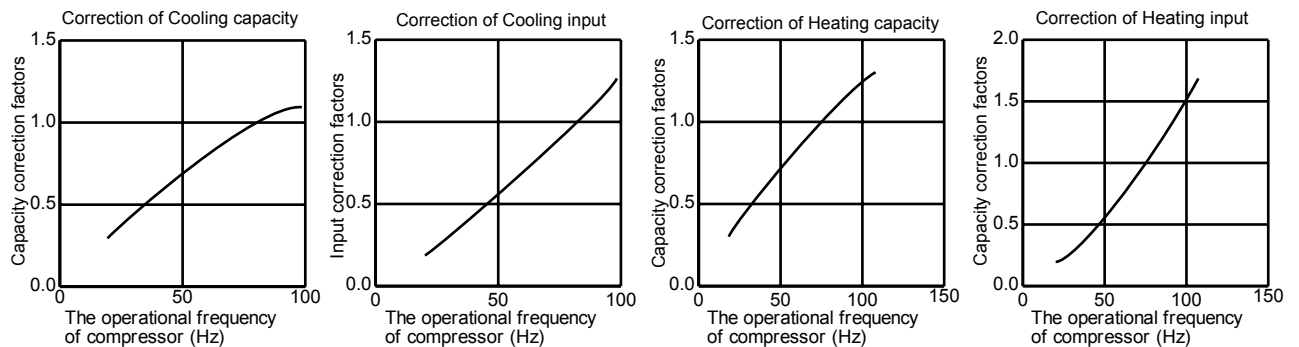

8-3. HOW TO OPERATE FIXED-FREQUENCY OPERATION

<Test run operation>

1. Press EMERGENCY OPERATION switch to start COOL or HEAT mode (COOL: Press once, HEAT: Press twice).
2. Test run operation starts and continues to operate for 30 minutes.
3. Compressor operates at rated frequency in COOL mode or 58 Hz in HEAT mode.
4. Indoor fan operates at High speed.
5. After 30 minutes, test run operation finishes and EMERGENCY OPERATION starts (operation frequency of compressor varies).
6. To cancel test run operation (EMERGENCY OPERATION), press EMERGENCY OPERATION switch or any button on remote controller.

8-4. OUTDOOR LOW PRESSURE AND OUTDOOR UNIT CURRENT

COOL operation

- ① Both indoor and outdoor unit are under the same temperature/humidity condition.
- ② Operation: TEST RUN OPERATION (Refer to 8-3.)

Dry-bulb temperature (°C)	Relative humidity (%)
20	50
25	60
30	70

Outdoor low pressure

MUZ-EF25VE MUZ-EF25VEH

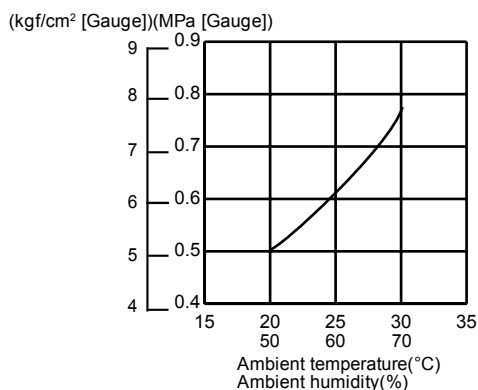

MUZ-EF35VE MUZ-EF35VEH

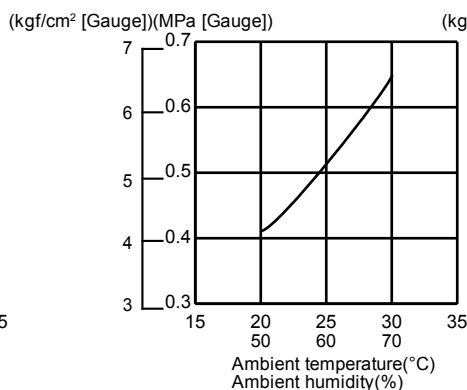

MUZ-EF42VE

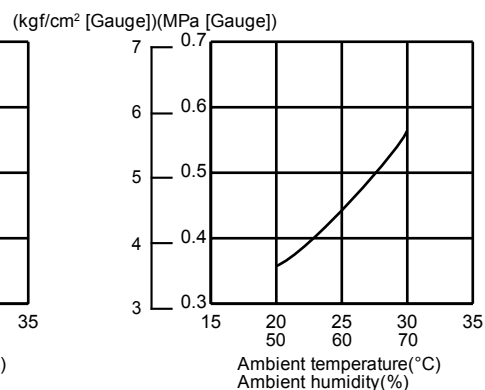

MUZ-EF50VE

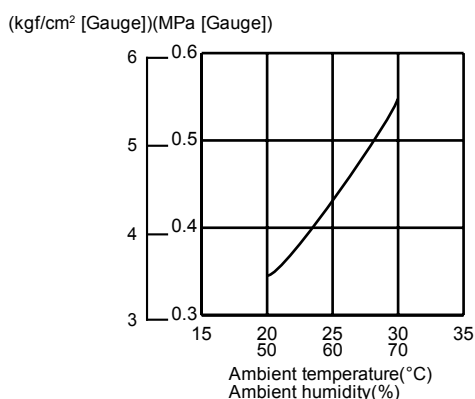

NOTE:

The unit of pressure has been changed to MPa on the international system of units (SI unit system)
The conversion factor is: **1 (MPa [Gauge]) = 10.2 (kgf/cm² [Gauge])**

Outdoor unit current

MUZ-EF25VE MUZ-EF25VEH

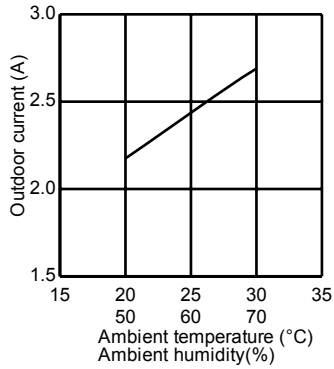

MUZ-EF35VE MUZ-EF35VEH

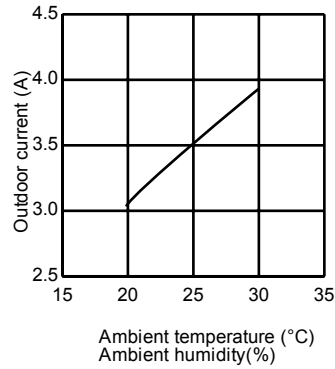

MUZ-EF42VE

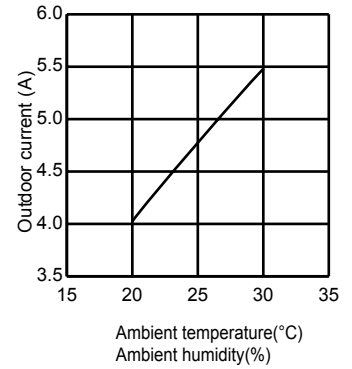

MUZ-EF50VE

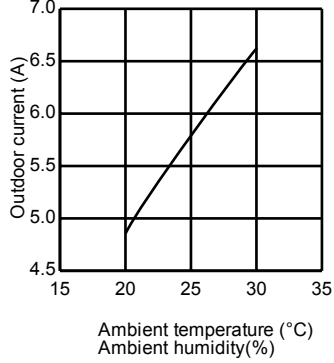

HEAT operation

① Condition:

	Indoor	Outdoor			
Dry bulb temperature (°C)	20.0	2	7	15	20.0
Wet bulb temperature (°C)	14.5	1	6	12	14.5

② Operation: Test run operation (Refer to 8-3.)

Outdoor unit current

MUZ-EF25VE MUZ-EF25VEH

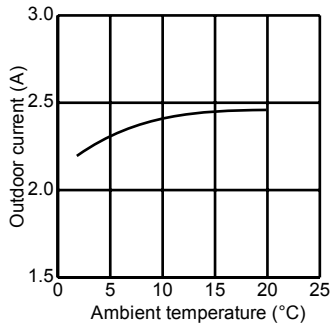

MUZ-EF35VE MUZ-EF35VEH

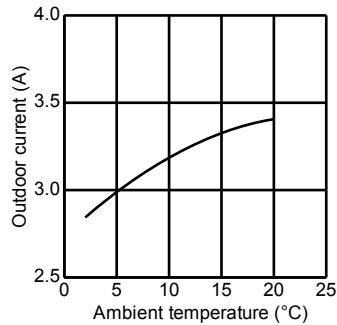

MUZ-EF42VE

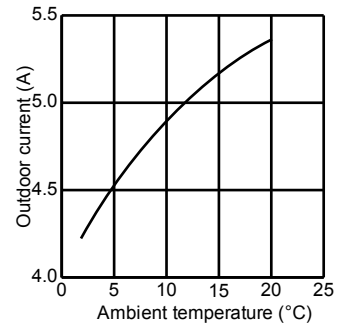

MUZ-EF50VE

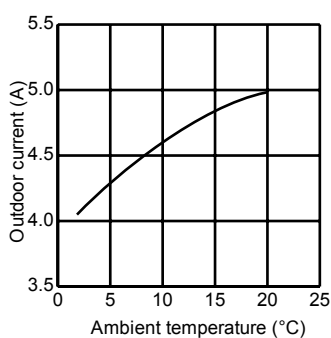

PERFORMANCE DATA COOL operation at Rated frequency

MUZ-EF25VE MUZ-EF25VEH

CAPACITY: 2.5 kW

SHF: 0.92

INPUT: 545 W

INDOOR DB (°C)	INDOOR WB (°C)	OUTDOOR DB (°C)															
		21				25				27				30			
		Q	SHC	SHF	INPUT	Q	SHC	SHF	INPUT	Q	SHC	SHF	INPUT	Q	SHC	SHF	INPUT
21	18	2.94	2.17	0.74	436	2.81	2.08	0.74	458	2.70	2.00	0.74	480	2.60	1.92	0.74	501
21	20	3.06	1.90	0.62	458	2.94	1.82	0.62	485	2.85	1.77	0.62	496	2.75	1.71	0.62	518
22	18	2.94	2.29	0.78	436	2.81	2.19	0.78	458	2.70	2.11	0.78	480	2.60	2.03	0.78	501
22	20	3.06	2.02	0.66	458	2.94	1.94	0.66	485	2.85	1.88	0.66	496	2.75	1.82	0.66	518
22	22	3.19	1.72	0.54	474	3.08	1.66	0.54	504	3.00	1.62	0.54	518	2.88	1.55	0.54	540
23	18	2.94	2.41	0.82	436	2.81	2.31	0.82	458	2.70	2.21	0.82	480	2.60	2.13	0.82	501
23	20	3.06	2.14	0.70	458	2.94	2.06	0.70	485	2.85	2.00	0.70	496	2.75	1.93	0.70	518
23	22	3.19	1.85	0.58	474	3.08	1.78	0.58	504	3.00	1.74	0.58	518	2.88	1.67	0.58	540
24	18	2.94	2.53	0.86	436	2.81	2.42	0.86	458	2.70	2.32	0.86	480	2.60	2.24	0.86	501
24	20	3.06	2.27	0.74	458	2.94	2.17	0.74	485	2.85	2.11	0.74	496	2.75	2.04	0.74	518
24	22	3.19	1.98	0.62	474	3.08	1.91	0.62	504	3.00	1.86	0.62	518	2.88	1.78	0.62	540
24	24	3.35	1.68	0.50	496	3.23	1.61	0.50	523	3.15	1.58	0.50	540	3.05	1.53	0.50	567
25	18	2.94	2.64	0.90	436	2.81	2.53	0.90	458	2.70	2.43	0.90	480	2.60	2.34	0.90	501
25	20	3.06	2.39	0.78	458	2.94	2.29	0.78	485	2.85	2.22	0.78	496	2.75	2.15	0.78	518
25	22	3.19	2.10	0.66	474	3.08	2.03	0.66	504	3.00	1.98	0.66	518	2.88	1.90	0.66	540
25	24	3.35	1.81	0.54	496	3.23	1.74	0.54	523	3.15	1.70	0.54	540	3.05	1.65	0.54	567
26	18	2.94	2.76	0.94	436	2.81	2.64	0.94	458	2.70	2.54	0.94	480	2.60	2.44	0.94	501
26	20	3.06	2.51	0.82	458	2.94	2.41	0.82	485	2.85	2.34	0.82	496	2.75	2.26	0.82	518
26	22	3.19	2.23	0.70	474	3.08	2.15	0.70	504	3.00	2.10	0.70	518	2.88	2.01	0.70	540
26	24	3.35	1.94	0.58	496	3.23	1.87	0.58	523	3.15	1.83	0.58	540	3.05	1.77	0.58	567
26	26	3.45	1.59	0.46	523	3.35	1.54	0.46	550	3.30	1.52	0.46	567	3.20	1.47	0.46	583
27	18	2.94	2.88	0.98	436	2.81	2.76	0.98	458	2.70	2.65	0.98	480	2.60	2.55	0.98	501
27	20	3.06	2.63	0.86	458	2.94	2.53	0.86	485	2.85	2.45	0.86	496	2.75	2.37	0.86	518
27	22	3.19	2.36	0.74	474	3.08	2.28	0.74	504	3.00	2.22	0.74	518	2.88	2.13	0.74	540
27	24	3.35	2.08	0.62	496	3.23	2.00	0.62	523	3.15	1.95	0.62	540	3.05	1.89	0.62	567
27	26	3.45	1.73	0.50	523	3.35	1.68	0.50	550	3.30	1.65	0.50	567	3.20	1.60	0.50	583
28	18	2.94	2.94	1.00	436	2.81	2.81	1.00	458	2.70	2.70	1.00	480	2.60	2.60	1.00	501
28	20	3.06	2.76	0.90	458	2.94	2.64	0.90	485	2.85	2.57	0.90	496	2.75	2.48	0.90	518
28	22	3.19	2.49	0.78	474	3.08	2.40	0.78	504	3.00	2.34	0.78	518	2.88	2.24	0.78	540
28	24	3.35	2.21	0.66	496	3.23	2.13	0.66	523	3.15	2.08	0.66	540	3.05	2.01	0.66	567
28	26	3.45	1.86	0.54	523	3.35	1.81	0.54	550	3.30	1.78	0.54	567	3.20	1.73	0.54	583
29	18	2.94	2.94	1.00	436	2.81	2.81	1.00	458	2.70	2.70	1.00	480	2.60	2.60	1.00	501
29	20	3.06	2.88	0.94	458	2.94	2.76	0.94	485	2.85	2.68	0.94	496	2.75	2.59	0.94	518
29	22	3.19	2.61	0.82	474	3.08	2.52	0.82	504	3.00	2.46	0.82	518	2.88	2.36	0.82	540
29	24	3.35	2.35	0.70	496	3.23	2.26	0.70	523	3.15	2.21	0.70	540	3.05	2.14	0.70	567
29	26	3.45	2.00	0.58	523	3.35	1.94	0.58	550	3.30	1.91	0.58	567	3.20	1.86	0.58	583
30	18	2.94	2.94	1.00	436	2.81	2.81	1.00	458	2.70	2.70	1.00	480	2.60	2.60	1.00	501
30	20	3.06	3.00	0.98	458	2.94	2.88	0.98	485	2.85	2.79	0.98	496	2.75	2.70	0.98	518
30	22	3.19	2.74	0.86	474	3.08	2.64	0.86	504	3.00	2.58	0.86	518	2.88	2.47	0.86	540
30	24	3.35	2.48	0.74	496	3.23	2.39	0.74	523	3.15	2.33	0.74	540	3.05	2.26	0.74	567
30	26	3.45	2.14	0.62	523	3.35	2.08	0.62	550	3.30	2.05	0.62	567	3.20	1.98	0.62	583
31	18	2.94	2.94	1.00	436	2.81	2.81	1.00	458	2.70	2.70	1.00	480	2.60	2.60	1.00	501
31	20	3.06	3.06	1.00	458	2.94	2.94	1.00	485	2.85	2.85	1.00	496	2.75	2.75	1.00	518
31	22	3.19	2.87	0.90	474	3.08	2.77	0.90	504	3.00	2.70	0.90	518	2.88	2.59	0.90	540
31	24	3.35	2.61	0.78	496	3.23	2.52	0.78	523	3.15	2.46	0.78	540	3.05	2.38	0.78	567
31	26	3.45	2.28	0.66	523	3.35	2.21	0.66	550	3.30	2.18	0.66	567	3.20	2.11	0.66	583
32	18	2.94	2.94	1.00	436	2.81	2.81	1.00	458	2.70	2.70	1.00	480	2.60	2.60	1.00	501
32	20	3.06	3.06	1.00	458	2.94	2.94	1.00	485	2.85	2.85	1.00	496	2.75	2.75	1.00	518
32	22	3.19	3.00	0.94	474	3.08	2.89	0.94	504	3.00	2.82	0.94	518	2.88	2.70	0.94	540
32	24	3.35	2.75	0.82	496	3.23	2.64	0.82	523	3.15	2.58	0.82	540	3.05	2.50	0.82	567
32	26	3.45	2.42	0.70	523	3.35	2.35	0.70	550	3.30	2.31	0.70	567	3.20	2.24	0.70	583

NOTE Q : Total capacity (kW) SHF : Sensible heat factor DB : Dry-bulb temperature
 SHC : Sensible heat capacity (kW) INPUT : Total power input (W) WB : Wet-bulb temperature

PERFORMANCE DATA COOL operation at Rated frequency
MUZ-EF25VE MUZ-EF25VEH

CAPACITY: 2.5 kW SHF: 0.92 INPUT: 545 W

INDOOR DB (°C)	INDOOR WB (°C)	OUTDOOR DB (°C)											
		35				40				46			
		Q	SHC	SHF	INPUT	Q	SHC	SHF	INPUT	Q	SHC	SHF	INPUT
21	18	2.45	1.81	0.74	534	2.25	1.67	0.74	567	2.08	1.54	0.74	589
21	20	2.58	1.60	0.62	556	2.40	1.49	0.62	583	2.23	1.38	0.62	616
22	18	2.45	1.91	0.78	534	2.25	1.76	0.78	567	2.08	1.62	0.78	589
22	20	2.58	1.70	0.66	556	2.40	1.58	0.66	583	2.23	1.47	0.66	616
22	22	2.73	1.47	0.54	578	2.55	1.38	0.54	610	2.38	1.28	0.54	632
23	18	2.45	2.01	0.82	534	2.25	1.85	0.82	567	2.08	1.70	0.82	589
23	20	2.58	1.80	0.70	556	2.40	1.68	0.70	583	2.23	1.56	0.70	616
23	22	2.73	1.58	0.58	578	2.55	1.48	0.58	610	2.38	1.38	0.58	632
24	18	2.45	2.11	0.86	534	2.25	1.94	0.86	567	2.08	1.78	0.86	589
24	20	2.58	1.91	0.74	556	2.40	1.78	0.74	583	2.23	1.65	0.74	616
24	22	2.73	1.69	0.62	578	2.55	1.58	0.62	610	2.38	1.47	0.62	632
24	24	2.88	1.44	0.50	600	2.70	1.35	0.50	627	2.55	1.28	0.50	654
25	18	2.45	2.21	0.90	534	2.25	2.03	0.90	567	2.08	1.87	0.9	589
25	20	2.58	2.01	0.78	556	2.40	1.87	0.78	583	2.23	1.74	0.78	616
25	22	2.73	1.80	0.66	578	2.55	1.68	0.66	610	2.38	1.57	0.66	632
25	24	2.88	1.55	0.54	600	2.70	1.46	0.54	627	2.55	1.38	0.54	654
26	18	2.45	2.30	0.94	534	2.25	2.12	0.94	567	2.08	1.95	0.94	589
26	20	2.58	2.11	0.82	556	2.40	1.97	0.82	583	2.23	1.82	0.82	616
26	22	2.73	1.91	0.70	578	2.55	1.79	0.70	610	2.38	1.66	0.70	632
26	24	2.88	1.67	0.58	600	2.70	1.57	0.58	627	2.55	1.48	0.58	654
26	26	3.03	1.39	0.46	621	2.85	1.31	0.46	649	2.68	1.23	0.46	676
27	18	2.45	2.40	0.98	534	2.25	2.21	0.98	567	2.08	2.03	0.98	589
27	20	2.58	2.21	0.86	556	2.40	2.06	0.86	583	2.23	1.91	0.86	616
27	22	2.73	2.02	0.74	578	2.55	1.89	0.74	610	2.38	1.76	0.74	632
27	24	2.88	1.78	0.62	600	2.70	1.67	0.62	627	2.55	1.58	0.62	654
27	26	3.03	1.51	0.50	621	2.85	1.43	0.50	649	2.68	1.34	0.50	676
28	18	2.45	2.45	1.00	534	2.25	2.25	1.00	567	2.08	2.08	1.00	589
28	20	2.58	2.32	0.90	556	2.40	2.16	0.90	583	2.23	2.00	0.90	616
28	22	2.73	2.13	0.78	578	2.55	1.99	0.78	610	2.38	1.85	0.78	632
28	24	2.88	1.90	0.66	600	2.70	1.78	0.66	627	2.55	1.68	0.66	654
28	26	3.03	1.63	0.54	621	2.85	1.54	0.54	649	2.68	1.44	0.54	676
29	18	2.45	2.45	1.00	534	2.25	2.25	1.00	567	2.08	2.08	1.00	589
29	20	2.58	2.42	0.94	556	2.40	2.26	0.94	583	2.23	2.09	0.94	616
29	22	2.73	2.23	0.82	578	2.55	2.09	0.82	610	2.38	1.95	0.82	632
29	24	2.88	2.01	0.70	600	2.70	1.89	0.70	627	2.55	1.79	0.70	654
29	26	3.03	1.75	0.58	621	2.85	1.65	0.58	649	2.68	1.55	0.58	676
30	18	2.45	2.45	1.00	534	2.25	2.25	1.00	567	2.08	2.08	1.00	589
30	20	2.58	2.52	0.98	556	2.40	2.35	0.98	583	2.23	2.18	0.98	616
30	22	2.73	2.34	0.86	578	2.55	2.19	0.86	610	2.38	2.04	0.86	632
30	24	2.88	2.13	0.74	600	2.70	2.00	0.74	627	2.55	1.89	0.74	654
30	26	3.03	1.88	0.62	621	2.85	1.77	0.62	649	2.68	1.66	0.62	676
31	18	2.45	2.45	1.00	534	2.25	2.25	1.00	567	2.08	2.08	1.00	589
31	20	2.58	2.58	1.00	556	2.40	2.40	1.00	583	2.23	2.23	1.00	616
31	22	2.73	2.45	0.90	578	2.55	2.30	0.90	610	2.38	2.14	0.90	632
31	24	2.88	2.24	0.78	600	2.70	2.11	0.78	627	2.55	1.99	0.78	654
31	26	3.03	2.00	0.66	621	2.85	1.88	0.66	649	2.68	1.77	0.66	676
32	18	2.45	2.45	1.00	534	2.25	2.25	1.00	567	2.08	2.08	1.00	589
32	20	2.58	2.58	1.00	556	2.40	2.40	1.00	583	2.23	2.23	1.00	616
32	22	2.73	2.56	0.94	578	2.55	2.40	0.94	610	2.38	2.23	0.94	632
32	24	2.88	2.36	0.82	600	2.70	2.21	0.82	627	2.55	2.09	0.82	654
32	26	3.03	2.12	0.70	621	2.85	2.00	0.70	649	2.68	1.87	0.70	676

NOTE Q : Total capacity (kW) SHF : Sensible heat factor DB : Dry-bulb temperature
 SHC : Sensible heat capacity (kW) INPUT : Total power input (W) WB : Wet-bulb temperature

PERFORMANCE DATA COOL operation at Rated frequency

MUZ-EF35VE MUZ-EF35VEH

CAPACITY: 3.5 kW

SHF: 0.80

INPUT: 910 W

INDOOR DB (°C)	INDOOR WB (°C)	OUTDOOR DB (°C)															
		21				25				27				30			
		Q	SHC	SHF	INPUT	Q	SHC	SHF	INPUT	Q	SHC	SHF	INPUT	Q	SHC	SHF	INPUT
21	18	4.11	2.55	0.62	728	3.94	2.44	0.62	764	3.78	2.34	0.62	801	3.64	2.26	0.62	837
21	20	4.29	2.14	0.50	764	4.11	2.06	0.50	810	3.99	2.00	0.50	828	3.85	1.93	0.50	865
22	18	4.11	2.71	0.66	728	3.94	2.60	0.66	764	3.78	2.49	0.66	801	3.64	2.40	0.66	837
22	20	4.29	2.32	0.54	764	4.11	2.22	0.54	810	3.99	2.15	0.54	828	3.85	2.08	0.54	865
22	22	4.46	1.87	0.42	792	4.31	1.81	0.42	842	4.20	1.76	0.42	865	4.03	1.69	0.42	901
23	18	4.11	2.88	0.70	728	3.94	2.76	0.70	764	3.78	2.65	0.70	801	3.64	2.55	0.70	837
23	20	4.29	2.49	0.58	764	4.11	2.39	0.58	810	3.99	2.31	0.58	828	3.85	2.23	0.58	865
23	22	4.46	2.05	0.46	792	4.31	1.98	0.46	842	4.20	1.93	0.46	865	4.03	1.85	0.46	901
24	18	4.11	3.04	0.74	728	3.94	2.91	0.74	764	3.78	2.80	0.74	801	3.64	2.69	0.74	837
24	20	4.29	2.66	0.62	764	4.11	2.55	0.62	810	3.99	2.47	0.62	828	3.85	2.39	0.62	865
24	22	4.46	2.23	0.50	792	4.31	2.15	0.50	842	4.20	2.10	0.50	865	4.03	2.01	0.50	901
24	24	4.69	1.78	0.38	828	4.52	1.72	0.38	874	4.41	1.68	0.38	901	4.27	1.62	0.38	946
25	18	4.11	3.21	0.78	728	3.94	3.07	0.78	764	3.78	2.95	0.78	801	3.64	2.84	0.78	837
25	20	4.29	2.83	0.66	764	4.11	2.71	0.66	810	3.99	2.63	0.66	828	3.85	2.54	0.66	865
25	22	4.46	2.41	0.54	792	4.31	2.32	0.54	842	4.20	2.27	0.54	865	4.03	2.17	0.54	901
25	24	4.69	1.97	0.42	828	4.52	1.90	0.42	874	4.41	1.85	0.42	901	4.27	1.79	0.42	946
26	18	4.11	3.37	0.82	728	3.94	3.23	0.82	764	3.78	3.10	0.82	801	3.64	2.98	0.82	837
26	20	4.29	3.00	0.70	764	4.11	2.88	0.70	810	3.99	2.79	0.70	828	3.85	2.70	0.70	865
26	22	4.46	2.59	0.58	792	4.31	2.50	0.58	842	4.20	2.44	0.58	865	4.03	2.33	0.58	901
26	24	4.69	2.16	0.46	828	4.52	2.08	0.46	874	4.41	2.03	0.46	901	4.27	1.96	0.46	946
26	26	4.83	1.64	0.34	874	4.69	1.59	0.34	919	4.62	1.57	0.34	946	4.48	1.52	0.34	974
27	18	4.11	3.54	0.86	728	3.94	3.39	0.86	764	3.78	3.25	0.86	801	3.64	3.13	0.86	837
27	20	4.29	3.17	0.74	764	4.11	3.04	0.74	810	3.99	2.95	0.74	828	3.85	2.85	0.74	865
27	22	4.46	2.77	0.62	792	4.31	2.67	0.62	842	4.20	2.60	0.62	865	4.03	2.50	0.62	901
27	24	4.69	2.35	0.50	828	4.52	2.26	0.50	874	4.41	2.21	0.50	901	4.27	2.14	0.50	946
27	26	4.83	1.84	0.38	874	4.69	1.78	0.38	919	4.62	1.76	0.38	946	4.48	1.70	0.38	974
28	18	4.11	3.70	0.90	728	3.94	3.54	0.90	764	3.78	3.40	0.90	801	3.64	3.28	0.90	837
28	20	4.29	3.34	0.78	764	4.11	3.21	0.78	810	3.99	3.11	0.78	828	3.85	3.00	0.78	865
28	22	4.46	2.95	0.66	792	4.31	2.84	0.66	842	4.20	2.77	0.66	865	4.03	2.66	0.66	901
28	24	4.69	2.53	0.54	828	4.52	2.44	0.54	874	4.41	2.38	0.54	901	4.27	2.31	0.54	946
28	26	4.83	2.03	0.42	874	4.69	1.97	0.42	919	4.62	1.94	0.42	946	4.48	1.88	0.42	974
29	18	4.11	3.87	0.94	728	3.94	3.70	0.94	764	3.78	3.55	0.94	801	3.64	3.42	0.94	837
29	20	4.29	3.52	0.82	764	4.11	3.37	0.82	810	3.99	3.27	0.82	828	3.85	3.16	0.82	865
29	22	4.46	3.12	0.70	792	4.31	3.01	0.70	842	4.20	2.94	0.70	865	4.03	2.82	0.70	901
29	24	4.69	2.72	0.58	828	4.52	2.62	0.58	874	4.41	2.56	0.58	901	4.27	2.48	0.58	946
29	26	4.83	2.22	0.46	874	4.69	2.16	0.46	919	4.62	2.13	0.46	946	4.48	2.06	0.46	974
30	18	4.11	4.03	0.98	728	3.94	3.86	0.98	764	3.78	3.70	0.98	801	3.64	3.57	0.98	837
30	20	4.29	3.69	0.86	764	4.11	3.54	0.86	810	3.99	3.43	0.86	828	3.85	3.31	0.86	865
30	22	4.46	3.30	0.74	792	4.31	3.19	0.74	842	4.20	3.11	0.74	865	4.03	2.98	0.74	901
30	24	4.69	2.91	0.62	828	4.52	2.80	0.62	874	4.41	2.73	0.62	901	4.27	2.65	0.62	946
30	26	4.83	2.42	0.50	874	4.69	2.35	0.50	919	4.62	2.31	0.50	946	4.48	2.24	0.50	974
31	18	4.11	4.11	1.00	728	3.94	3.94	1.00	764	3.78	3.78	1.00	801	3.64	3.64	1.00	837
31	20	4.29	3.86	0.90	764	4.11	3.70	0.90	810	3.99	3.59	0.90	828	3.85	3.47	0.90	865
31	22	4.46	3.48	0.78	792	4.31	3.36	0.78	842	4.20	3.28	0.78	865	4.03	3.14	0.78	901
31	24	4.69	3.10	0.66	828	4.52	2.98	0.66	874	4.41	2.91	0.66	901	4.27	2.82	0.66	946
31	26	4.83	2.61	0.54	874	4.69	2.53	0.54	919	4.62	2.49	0.54	946	4.48	2.42	0.54	974
32	18	4.11	4.11	1.00	728	3.94	3.94	1.00	764	3.78	3.78	1.00	801	3.64	3.64	1.00	837
32	20	4.29	4.03	0.94	764	4.11	3.87	0.94	810	3.99	3.75	0.94	828	3.85	3.62	0.94	865
32	22	4.46	3.66	0.82	792	4.31	3.53	0.82	842	4.20	3.44	0.82	865	4.03	3.30	0.82	901
32	24	4.69	3.28	0.70	828	4.52	3.16	0.70	874	4.41	3.09	0.70	901	4.27	2.99	0.70	946
32	26	4.83	2.80	0.58	874	4.69	2.72	0.58	919	4.62	2.68	0.58	946	4.48	2.60	0.58	974

NOTE Q : Total capacity (kW) SHF : Sensible heat factor DB : Dry-bulb temperature
 SHC : Sensible heat capacity (kW) INPUT : Total power input (W) WB : Wet-bulb temperature

PERFORMANCE DATA COOL operation at Rated frequency
MUZ-EF35VE MUZ-EF35VEH

CAPACITY: 3.5 kW SHF: 0.80 INPUT: 910 W

INDOOR DB (°C)	INDOOR WB (°C)	OUTDOOR DB (°C)											
		35				40				46			
		Q	SHC	SHF	INPUT	Q	SHC	SHF	INPUT	Q	SHC	SHF	INPUT
21	18	3.43	2.13	0.62	892	3.15	1.95	0.62	946	2.91	1.80	0.62	983
21	20	3.61	1.80	0.50	928	3.36	1.68	0.50	974	3.12	1.56	0.50	1028
22	18	3.43	2.26	0.66	892	3.15	2.08	0.66	946	2.91	1.92	0.66	983
22	20	3.61	1.95	0.54	928	3.36	1.81	0.54	974	3.12	1.68	0.54	1028
22	22	3.82	1.60	0.42	965	3.57	1.50	0.42	1019	3.33	1.40	0.42	1056
23	18	3.43	2.40	0.70	892	3.15	2.21	0.70	946	2.91	2.03	0.70	983
23	20	3.61	2.09	0.58	928	3.36	1.95	0.58	974	3.12	1.81	0.58	1028
23	22	3.82	1.75	0.46	965	3.57	1.64	0.46	1019	3.33	1.53	0.46	1056
24	18	3.43	2.54	0.74	892	3.15	2.33	0.74	946	2.91	2.15	0.74	983
24	20	3.61	2.24	0.62	928	3.36	2.08	0.62	974	3.12	1.93	0.62	1028
24	22	3.82	1.91	0.50	965	3.57	1.79	0.50	1019	3.33	1.66	0.50	1056
24	24	4.03	1.53	0.38	1001	3.78	1.44	0.38	1047	3.57	1.36	0.38	1092
25	18	3.43	2.68	0.78	892	3.15	2.46	0.78	946	2.91	2.27	0.78	983
25	20	3.61	2.38	0.66	928	3.36	2.22	0.66	974	3.12	2.06	0.66	1028
25	22	3.82	2.06	0.54	965	3.57	1.93	0.54	1019	3.33	1.80	0.54	1056
25	24	4.03	1.69	0.42	1001	3.78	1.59	0.42	1047	3.57	1.50	0.42	1092
26	18	3.43	2.81	0.82	892	3.15	2.58	0.82	946	2.91	2.38	0.82	983
26	20	3.61	2.52	0.70	928	3.36	2.35	0.70	974	3.12	2.18	0.70	1028
26	22	3.82	2.21	0.58	965	3.57	2.07	0.58	1019	3.33	1.93	0.58	1056
26	24	4.03	1.85	0.46	1001	3.78	1.74	0.46	1047	3.57	1.64	0.46	1092
26	26	4.24	1.44	0.34	1037	3.99	1.36	0.34	1083	3.75	1.27	0.34	1128
27	18	3.43	2.95	0.86	892	3.15	2.71	0.86	946	2.91	2.50	0.86	983
27	20	3.61	2.67	0.74	928	3.36	2.49	0.74	974	3.12	2.31	0.74	1028
27	22	3.82	2.37	0.62	965	3.57	2.21	0.62	1019	3.33	2.06	0.62	1056
27	24	4.03	2.01	0.50	1001	3.78	1.89	0.50	1047	3.57	1.79	0.50	1092
27	26	4.24	1.61	0.38	1037	3.99	1.52	0.38	1083	3.75	1.42	0.38	1128
28	18	3.43	3.09	0.90	892	3.15	2.84	0.90	946	2.91	2.61	0.90	983
28	20	3.61	2.81	0.78	928	3.36	2.62	0.78	974	3.12	2.43	0.78	1028
28	22	3.82	2.52	0.66	965	3.57	2.36	0.66	1019	3.33	2.19	0.66	1056
28	24	4.03	2.17	0.54	1001	3.78	2.04	0.54	1047	3.57	1.93	0.54	1092
28	26	4.24	1.78	0.42	1037	3.99	1.68	0.42	1083	3.75	1.57	0.42	1128
29	18	3.43	3.22	0.94	892	3.15	2.96	0.94	946	2.91	2.73	0.94	983
29	20	3.61	2.96	0.82	928	3.36	2.76	0.82	974	3.12	2.55	0.82	1028
29	22	3.82	2.67	0.70	965	3.57	2.50	0.70	1019	3.33	2.33	0.70	1056
29	24	4.03	2.33	0.58	1001	3.78	2.19	0.58	1047	3.57	2.07	0.58	1092
29	26	4.24	1.95	0.46	1037	3.99	1.84	0.46	1083	3.75	1.72	0.46	1128
30	18	3.43	3.36	0.98	892	3.15	3.09	0.98	946	2.91	2.85	0.98	983
30	20	3.61	3.10	0.86	928	3.36	2.89	0.86	974	3.12	2.68	0.86	1028
30	22	3.82	2.82	0.74	965	3.57	2.64	0.74	1019	3.33	2.46	0.74	1056
30	24	4.03	2.50	0.62	1001	3.78	2.34	0.62	1047	3.57	2.21	0.62	1092
30	26	4.24	2.12	0.50	1037	3.99	2.00	0.50	1083	3.75	1.87	0.50	1128
31	18	3.43	3.43	1.00	892	3.15	3.15	1.00	946	2.91	2.91	1.00	983
31	20	3.61	3.24	0.90	928	3.36	3.02	0.90	974	3.12	2.80	0.90	1028
31	22	3.82	2.98	0.78	965	3.57	2.78	0.78	1019	3.33	2.59	0.78	1056
31	24	4.03	2.66	0.66	1001	3.78	2.49	0.66	1047	3.57	2.36	0.66	1092
31	26	4.24	2.29	0.54	1037	3.99	2.15	0.54	1083	3.75	2.02	0.54	1128
32	18	3.43	3.43	1.00	892	3.15	3.15	1.00	946	2.91	2.91	1.00	983
32	20	3.61	3.39	0.94	928	3.36	3.16	0.94	974	3.12	2.93	0.94	1028
32	22	3.82	3.13	0.82	965	3.57	2.93	0.82	1019	3.33	2.73	0.82	1056
32	24	4.03	2.82	0.70	1001	3.78	2.65	0.70	1047	3.57	2.50	0.70	1092
32	26	4.24	2.46	0.58	1037	3.99	2.31	0.58	1083	3.75	2.17	0.58	1128

NOTE Q : Total capacity (kW) SHF : Sensible heat factor DB : Dry-bulb temperature
SHC : Sensible heat capacity (kW) INPUT : Total power input (W) WB : Wet-bulb temperature

PERFORMANCE DATA COOL operation at Rated frequency

MUZ-EF42VE

CAPACITY: 4.2 kW

SHF: 0.72

INPUT: 1280 W

INDOOR DB (°C)	INDOOR WB (°C)	OUTDOOR DB (°C)															
		21				25				27				30			
		Q	SHC	SHF	INPUT	Q	SHC	SHF	INPUT	Q	SHC	SHF	INPUT	Q	SHC	SHF	INPUT
21	18	4.94	2.66	0.54	1024	4.73	2.55	0.54	1075	4.54	2.45	0.54	1126	4.37	2.36	0.54	1178
21	20	5.15	2.16	0.42	1075	4.94	2.07	0.42	1139	4.79	2.01	0.42	1165	4.62	1.94	0.42	1216
22	18	4.94	2.86	0.58	1024	4.73	2.74	0.58	1075	4.54	2.63	0.58	1126	4.37	2.53	0.58	1178
22	20	5.15	2.37	0.46	1075	4.94	2.27	0.46	1139	4.79	2.20	0.46	1165	4.62	2.13	0.46	1216
22	22	5.36	1.82	0.34	1114	5.17	1.76	0.34	1184	5.04	1.71	0.34	1216	4.83	1.64	0.34	1267
23	18	4.94	3.06	0.62	1024	4.73	2.93	0.62	1075	4.54	2.81	0.62	1126	4.37	2.71	0.62	1178
23	20	5.15	2.57	0.50	1075	4.94	2.47	0.50	1139	4.79	2.39	0.50	1165	4.62	2.31	0.50	1216
23	22	5.36	2.03	0.38	1114	5.17	1.96	0.38	1184	5.04	1.92	0.38	1216	4.83	1.84	0.38	1267
24	18	4.94	3.26	0.66	1024	4.73	3.12	0.66	1075	4.54	2.99	0.66	1126	4.37	2.88	0.66	1178
24	20	5.15	2.78	0.54	1075	4.94	2.66	0.54	1139	4.79	2.59	0.54	1165	4.62	2.49	0.54	1216
24	22	5.36	2.25	0.42	1114	5.17	2.17	0.42	1184	5.04	2.12	0.42	1216	4.83	2.03	0.42	1267
24	24	5.63	1.69	0.30	1165	5.42	1.63	0.30	1229	5.29	1.59	0.30	1267	5.12	1.54	0.30	1331
25	18	4.94	3.45	0.70	1024	4.73	3.31	0.70	1075	4.54	3.18	0.70	1126	4.37	3.06	0.70	1178
25	20	5.15	2.98	0.58	1075	4.94	2.86	0.58	1139	4.79	2.78	0.58	1165	4.62	2.68	0.58	1216
25	22	5.36	2.46	0.46	1114	5.17	2.38	0.46	1184	5.04	2.32	0.46	1216	4.83	2.22	0.46	1267
25	24	5.63	1.91	0.34	1165	5.42	1.84	0.34	1229	5.29	1.80	0.34	1267	5.12	1.74	0.34	1331
26	18	4.94	3.65	0.74	1024	4.73	3.50	0.74	1075	4.54	3.36	0.74	1126	4.37	3.23	0.74	1178
26	20	5.15	3.19	0.62	1075	4.94	3.06	0.62	1139	4.79	2.97	0.62	1165	4.62	2.86	0.62	1216
26	22	5.36	2.68	0.50	1114	5.17	2.58	0.50	1184	5.04	2.52	0.50	1216	4.83	2.42	0.50	1267
26	24	5.63	2.14	0.38	1165	5.42	2.06	0.38	1229	5.29	2.01	0.38	1267	5.12	1.95	0.38	1331
26	26	5.80	1.51	0.26	1229	5.63	1.46	0.26	1293	5.54	1.44	0.26	1331	5.38	1.40	0.26	1370
27	18	4.94	3.85	0.78	1024	4.73	3.69	0.78	1075	4.54	3.54	0.78	1126	4.37	3.41	0.78	1178
27	20	5.15	3.40	0.66	1075	4.94	3.26	0.66	1139	4.79	3.16	0.66	1165	4.62	3.05	0.66	1216
27	22	5.36	2.89	0.54	1114	5.17	2.79	0.54	1184	5.04	2.72	0.54	1216	4.83	2.61	0.54	1267
27	24	5.63	2.36	0.42	1165	5.42	2.28	0.42	1229	5.29	2.22	0.42	1267	5.12	2.15	0.42	1331
27	26	5.80	1.74	0.30	1229	5.63	1.69	0.30	1293	5.54	1.66	0.30	1331	5.38	1.61	0.30	1370
28	18	4.94	4.05	0.82	1024	4.73	3.87	0.82	1075	4.54	3.72	0.82	1126	4.37	3.58	0.82	1178
28	20	5.15	3.60	0.70	1075	4.94	3.45	0.70	1139	4.79	3.35	0.70	1165	4.62	3.23	0.70	1216
28	22	5.36	3.11	0.58	1114	5.17	3.00	0.58	1184	5.04	2.92	0.58	1216	4.83	2.80	0.58	1267
28	24	5.63	2.59	0.46	1165	5.42	2.49	0.46	1229	5.29	2.43	0.46	1267	5.12	2.36	0.46	1331
28	26	5.80	1.97	0.34	1229	5.63	1.91	0.34	1293	5.54	1.88	0.34	1331	5.38	1.83	0.34	1370
29	18	4.94	4.24	0.86	1024	4.73	4.06	0.86	1075	4.54	3.90	0.86	1126	4.37	3.76	0.86	1178
29	20	5.15	3.81	0.74	1075	4.94	3.65	0.74	1139	4.79	3.54	0.74	1165	4.62	3.42	0.74	1216
29	22	5.36	3.32	0.62	1114	5.17	3.20	0.62	1184	5.04	3.12	0.62	1216	4.83	2.99	0.62	1267
29	24	5.63	2.81	0.50	1165	5.42	2.71	0.50	1229	5.29	2.65	0.50	1267	5.12	2.56	0.50	1331
29	26	5.80	2.20	0.38	1229	5.63	2.14	0.38	1293	5.54	2.11	0.38	1331	5.38	2.04	0.38	1370
30	18	4.94	4.44	0.90	1024	4.73	4.25	0.90	1075	4.54	4.08	0.90	1126	4.37	3.93	0.90	1178
30	20	5.15	4.01	0.78	1075	4.94	3.85	0.78	1139	4.79	3.73	0.78	1165	4.62	3.60	0.78	1216
30	22	5.36	3.53	0.66	1114	5.17	3.41	0.66	1184	5.04	3.33	0.66	1216	4.83	3.19	0.66	1267
30	24	5.63	3.04	0.54	1165	5.42	2.93	0.54	1229	5.29	2.86	0.54	1267	5.12	2.77	0.54	1331
30	26	5.80	2.43	0.42	1229	5.63	2.36	0.42	1293	5.54	2.33	0.42	1331	5.38	2.26	0.42	1370
31	18	4.94	4.64	0.94	1024	4.73	4.44	0.94	1075	4.54	4.26	0.94	1126	4.37	4.11	0.94	1178
31	20	5.15	4.22	0.82	1075	4.94	4.05	0.82	1139	4.79	3.93	0.82	1165	4.62	3.79	0.82	1216
31	22	5.36	3.75	0.70	1114	5.17	3.62	0.70	1184	5.04	3.53	0.70	1216	4.83	3.38	0.70	1267
31	24	5.63	3.26	0.58	1165	5.42	3.14	0.58	1229	5.29	3.07	0.58	1267	5.12	2.97	0.58	1331
31	26	5.80	2.67	0.46	1229	5.63	2.59	0.46	1293	5.54	2.55	0.46	1331	5.38	2.47	0.46	1370
32	18	4.94	4.84	0.98	1024	4.73	4.63	0.98	1075	4.54	4.45	0.98	1126	4.37	4.28	0.98	1178
32	20	5.15	4.42	0.86	1075	4.94	4.24	0.86	1139	4.79	4.12	0.86	1165	4.62	3.97	0.86	1216
32	22	5.36	3.96	0.74	1114	5.17	3.82	0.74	1184	5.04	3.73	0.74	1216	4.83	3.57	0.74	1267
32	24	5.63	3.49	0.62	1165	5.42	3.36	0.62	1229	5.29	3.28	0.62	1267	5.12	3.18	0.62	1331
32	26	5.80	2.90	0.50	1229	5.63	2.81	0.50	1293	5.54	2.77	0.50	1331	5.38	2.69	0.50	1370

NOTE Q : Total capacity (kW) SHF : Sensible heat factor DB : Dry-bulb temperature
 SHC : Sensible heat capacity (kW) INPUT : Total power input (W) WB : Wet-bulb temperature

PERFORMANCE DATA COOL operation at Rated frequency
MUZ-EF42VE

CAPACITY: 4.2 kW SHF: 0.72 INPUT: 1280 W

INDOOR DB (°C)	INDOOR WB (°C)	OUTDOOR DB (°C)											
		35				40				46			
		Q	SHC	SHF	INPUT	Q	SHC	SHF	INPUT	Q	SHC	SHF	INPUT
21	18	4.12	2.22	0.54	1254	3.78	2.04	0.54	1331	3.49	1.88	0.54	1382
21	20	4.33	1.82	0.42	1306	4.03	1.69	0.42	1370	3.74	1.57	0.42	1446
22	18	4.12	2.39	0.58	1254	3.78	2.19	0.58	1331	3.49	2.02	0.58	1382
22	20	4.33	1.99	0.46	1306	4.03	1.85	0.46	1370	3.74	1.72	0.46	1446
22	22	4.58	1.56	0.34	1357	4.28	1.46	0.34	1434	3.99	1.36	0.34	1485
23	18	4.12	2.55	0.62	1254	3.78	2.34	0.62	1331	3.49	2.16	0.62	1382
23	20	4.33	2.16	0.50	1306	4.03	2.02	0.50	1370	3.74	1.87	0.50	1446
23	22	4.58	1.74	0.38	1357	4.28	1.63	0.38	1434	3.99	1.52	0.38	1485
24	18	4.12	2.72	0.66	1254	3.78	2.49	0.66	1331	3.49	2.30	0.66	1382
24	20	4.33	2.34	0.54	1306	4.03	2.18	0.54	1370	3.74	2.02	0.54	1446
24	22	4.58	1.92	0.42	1357	4.28	1.80	0.42	1434	3.99	1.68	0.42	1485
24	24	4.83	1.45	0.30	1408	4.54	1.36	0.30	1472	4.28	1.29	0.30	1536
25	18	4.12	2.88	0.70	1254	3.78	2.65	0.70	1331	3.49	2.44	0.7	1382
25	20	4.33	2.51	0.58	1306	4.03	2.34	0.58	1370	3.74	2.17	0.58	1446
25	22	4.58	2.11	0.46	1357	4.28	1.97	0.46	1434	3.99	1.84	0.46	1485
25	24	4.83	1.64	0.34	1408	4.54	1.54	0.34	1472	4.28	1.46	0.34	1536
26	18	4.12	3.05	0.74	1254	3.78	2.80	0.74	1331	3.49	2.58	0.74	1382
26	20	4.33	2.68	0.62	1306	4.03	2.50	0.62	1370	3.74	2.32	0.62	1446
26	22	4.58	2.29	0.50	1357	4.28	2.14	0.50	1434	3.99	2.00	0.50	1485
26	24	4.83	1.84	0.38	1408	4.54	1.72	0.38	1472	4.28	1.63	0.38	1536
26	26	5.08	1.32	0.26	1459	4.79	1.24	0.26	1523	4.49	1.17	0.26	1587
27	18	4.12	3.21	0.78	1254	3.78	2.95	0.78	1331	3.49	2.72	0.78	1382
27	20	4.33	2.86	0.66	1306	4.03	2.66	0.66	1370	3.74	2.47	0.66	1446
27	22	4.58	2.47	0.54	1357	4.28	2.31	0.54	1434	3.99	2.15	0.54	1485
27	24	4.83	2.03	0.42	1408	4.54	1.91	0.42	1472	4.28	1.80	0.42	1536
27	26	5.08	1.52	0.30	1459	4.79	1.44	0.30	1523	4.49	1.35	0.30	1587
28	18	4.12	3.38	0.82	1254	3.78	3.10	0.82	1331	3.49	2.86	0.82	1382
28	20	4.33	3.03	0.70	1306	4.03	2.82	0.70	1370	3.74	2.62	0.70	1446
28	22	4.58	2.66	0.58	1357	4.28	2.48	0.58	1434	3.99	2.31	0.58	1485
28	24	4.83	2.22	0.46	1408	4.54	2.09	0.46	1472	4.28	1.97	0.46	1536
28	26	5.08	1.73	0.34	1459	4.79	1.63	0.34	1523	4.49	1.53	0.34	1587
29	18	4.12	3.54	0.86	1254	3.78	3.25	0.86	1331	3.49	3.00	0.86	1382
29	20	4.33	3.20	0.74	1306	4.03	2.98	0.74	1370	3.74	2.77	0.74	1446
29	22	4.58	2.84	0.62	1357	4.28	2.66	0.62	1434	3.99	2.47	0.62	1485
29	24	4.83	2.42	0.50	1408	4.54	2.27	0.50	1472	4.28	2.14	0.50	1536
29	26	5.08	1.93	0.38	1459	4.79	1.82	0.38	1523	4.49	1.71	0.38	1587
30	18	4.12	3.70	0.90	1254	3.78	3.40	0.90	1331	3.49	3.14	0.90	1382
30	20	4.33	3.37	0.78	1306	4.03	3.14	0.78	1370	3.74	2.92	0.78	1446
30	22	4.58	3.02	0.66	1357	4.28	2.83	0.66	1434	3.99	2.63	0.66	1485
30	24	4.83	2.61	0.54	1408	4.54	2.45	0.54	1472	4.28	2.31	0.54	1536
30	26	5.08	2.13	0.42	1459	4.79	2.01	0.42	1523	4.49	1.89	0.42	1587
31	18	4.12	3.87	0.94	1254	3.78	3.55	0.94	1331	3.49	3.28	0.94	1382
31	20	4.33	3.55	0.82	1306	4.03	3.31	0.82	1370	3.74	3.07	0.82	1446
31	22	4.58	3.20	0.70	1357	4.28	3.00	0.70	1434	3.99	2.79	0.70	1485
31	24	4.83	2.80	0.58	1408	4.54	2.63	0.58	1472	4.28	2.48	0.58	1536
31	26	5.08	2.34	0.46	1459	4.79	2.20	0.46	1523	4.49	2.07	0.46	1587
32	18	4.12	4.03	0.98	1254	3.78	3.70	0.98	1331	3.49	3.42	0.98	1382
32	20	4.33	3.72	0.86	1306	4.03	3.47	0.86	1370	3.74	3.21	0.86	1446
32	22	4.58	3.39	0.74	1357	4.28	3.17	0.74	1434	3.99	2.95	0.74	1485
32	24	4.83	2.99	0.62	1408	4.54	2.81	0.62	1472	4.28	2.66	0.62	1536
32	26	5.08	2.54	0.50	1459	4.79	2.39	0.50	1523	4.49	2.25	0.50	1587

NOTE Q : Total capacity (kW) SHF : Sensible heat factor DB : Dry-bulb temperature
 SHC : Sensible heat capacity (kW) INPUT : Total power input (W) WB : Wet-bulb temperature

PERFORMANCE DATA COOL operation at Rated frequency

MUZ-EF50VE

CAPACITY: 5.0 kW

SHF: 0.71

INPUT: 1560 W

INDOOR DB (°C)	INDOOR WB (°C)	OUTDOOR DB (°C)															
		21				25				27				30			
		Q	SHC	SHF	INPUT	Q	SHC	SHF	INPUT	Q	SHC	SHF	INPUT	Q	SHC	SHF	INPUT
21	18	5.88	3.11	0.53	1248	5.63	2.98	0.53	1310	5.40	2.86	0.53	1373	5.20	2.76	0.53	1435
21	20	6.13	2.51	0.41	1310	5.88	2.41	0.41	1388	5.70	2.34	0.41	1420	5.50	2.26	0.41	1482
22	18	5.88	3.35	0.57	1248	5.63	3.21	0.57	1310	5.40	3.08	0.57	1373	5.20	2.96	0.57	1435
22	20	6.13	2.76	0.45	1310	5.88	2.64	0.45	1388	5.70	2.57	0.45	1420	5.50	2.48	0.45	1482
22	22	6.38	2.10	0.33	1357	6.15	2.03	0.33	1443	6.00	1.98	0.33	1482	5.75	1.90	0.33	1544
23	18	5.88	3.58	0.61	1248	5.63	3.43	0.61	1310	5.40	3.29	0.61	1373	5.20	3.17	0.61	1435
23	20	6.13	3.00	0.49	1310	5.88	2.88	0.49	1388	5.70	2.79	0.49	1420	5.50	2.70	0.49	1482
23	22	6.38	2.36	0.37	1357	6.15	2.28	0.37	1443	6.00	2.22	0.37	1482	5.75	2.13	0.37	1544
24	18	5.88	3.82	0.65	1248	5.63	3.66	0.65	1310	5.40	3.51	0.65	1373	5.20	3.38	0.65	1435
24	20	6.13	3.25	0.53	1310	5.88	3.11	0.53	1388	5.70	3.02	0.53	1420	5.50	2.92	0.53	1482
24	22	6.38	2.61	0.41	1357	6.15	2.52	0.41	1443	6.00	2.46	0.41	1482	5.75	2.36	0.41	1544
24	24	6.70	1.94	0.29	1420	6.45	1.87	0.29	1498	6.30	1.83	0.29	1544	6.10	1.77	0.29	1622
25	18	5.88	4.05	0.69	1248	5.63	3.88	0.69	1310	5.40	3.73	0.69	1373	5.20	3.59	0.69	1435
25	20	6.13	3.49	0.57	1310	5.88	3.35	0.57	1388	5.70	3.25	0.57	1420	5.50	3.14	0.57	1482
25	22	6.38	2.87	0.45	1357	6.15	2.77	0.45	1443	6.00	2.70	0.45	1482	5.75	2.59	0.45	1544
25	24	6.70	2.21	0.33	1420	6.45	2.13	0.33	1498	6.30	2.08	0.33	1544	6.10	2.01	0.33	1622
26	18	5.88	4.29	0.73	1248	5.63	4.11	0.73	1310	5.40	3.94	0.73	1373	5.20	3.80	0.73	1435
26	20	6.13	3.74	0.61	1310	5.88	3.58	0.61	1388	5.70	3.48	0.61	1420	5.50	3.36	0.61	1482
26	22	6.38	3.12	0.49	1357	6.15	3.01	0.49	1443	6.00	2.94	0.49	1482	5.75	2.82	0.49	1544
26	24	6.70	2.48	0.37	1420	6.45	2.39	0.37	1498	6.30	2.33	0.37	1544	6.10	2.26	0.37	1622
26	26	6.90	1.73	0.25	1498	6.70	1.68	0.25	1576	6.60	1.65	0.25	1622	6.40	1.60	0.25	1669
27	18	5.88	4.52	0.77	1248	5.63	4.33	0.77	1310	5.40	4.16	0.77	1373	5.20	4.00	0.77	1435
27	20	6.13	3.98	0.65	1310	5.88	3.82	0.65	1388	5.70	3.71	0.65	1420	5.50	3.58	0.65	1482
27	22	6.38	3.38	0.53	1357	6.15	3.26	0.53	1443	6.00	3.18	0.53	1482	5.75	3.05	0.53	1544
27	24	6.70	2.75	0.41	1420	6.45	2.64	0.41	1498	6.30	2.58	0.41	1544	6.10	2.50	0.41	1622
27	26	6.90	2.00	0.29	1498	6.70	1.94	0.29	1576	6.60	1.91	0.29	1622	6.40	1.86	0.29	1669
28	18	5.88	4.76	0.81	1248	5.63	4.56	0.81	1310	5.40	4.37	0.81	1373	5.20	4.21	0.81	1435
28	20	6.13	4.23	0.69	1310	5.88	4.05	0.69	1388	5.70	3.93	0.69	1420	5.50	3.80	0.69	1482
28	22	6.38	3.63	0.57	1357	6.15	3.51	0.57	1443	6.00	3.42	0.57	1482	5.75	3.28	0.57	1544
28	24	6.70	3.02	0.45	1420	6.45	2.90	0.45	1498	6.30	2.84	0.45	1544	6.10	2.75	0.45	1622
28	26	6.90	2.28	0.33	1498	6.70	2.21	0.33	1576	6.60	2.18	0.33	1622	6.40	2.11	0.33	1669
29	18	5.88	4.99	0.85	1248	5.63	4.78	0.85	1310	5.40	4.59	0.85	1373	5.20	4.42	0.85	1435
29	20	6.13	4.47	0.73	1310	5.88	4.29	0.73	1388	5.70	4.16	0.73	1420	5.50	4.02	0.73	1482
29	22	6.38	3.89	0.61	1357	6.15	3.75	0.61	1443	6.00	3.66	0.61	1482	5.75	3.51	0.61	1544
29	24	6.70	3.28	0.49	1420	6.45	3.16	0.49	1498	6.30	3.09	0.49	1544	6.10	2.99	0.49	1622
29	26	6.90	2.55	0.37	1498	6.70	2.48	0.37	1576	6.60	2.44	0.37	1622	6.40	2.37	0.37	1669
30	18	5.88	5.23	0.89	1248	5.63	5.01	0.89	1310	5.40	4.81	0.89	1373	5.20	4.63	0.89	1435
30	20	6.13	4.72	0.77	1310	5.88	4.52	0.77	1388	5.70	4.39	0.77	1420	5.50	4.24	0.77	1482
30	22	6.38	4.14	0.65	1357	6.15	4.00	0.65	1443	6.00	3.90	0.65	1482	5.75	3.74	0.65	1544
30	24	6.70	3.55	0.53	1420	6.45	3.42	0.53	1498	6.30	3.34	0.53	1544	6.10	3.23	0.53	1622
30	26	6.90	2.83	0.41	1498	6.70	2.75	0.41	1576	6.60	2.71	0.41	1622	6.40	2.62	0.41	1669
31	18	5.88	5.46	0.93	1248	5.63	5.23	0.93	1310	5.40	5.02	0.93	1373	5.20	4.84	0.93	1435
31	20	6.13	4.96	0.81	1310	5.88	4.76	0.81	1388	5.70	4.62	0.81	1420	5.50	4.46	0.81	1482
31	22	6.38	4.40	0.69	1357	6.15	4.24	0.69	1443	6.00	4.14	0.69	1482	5.75	3.97	0.69	1544
31	24	6.70	3.82	0.57	1420	6.45	3.68	0.57	1498	6.30	3.59	0.57	1544	6.10	3.48	0.57	1622
31	26	6.90	3.11	0.45	1498	6.70	3.02	0.45	1576	6.60	2.97	0.45	1622	6.40	2.88	0.45	1669
32	18	5.88	5.70	0.97	1248	5.63	5.46	0.97	1310	5.40	5.24	0.97	1373	5.20	5.04	0.97	1435
32	20	6.13	5.21	0.85	1310	5.88	4.99	0.85	1388	5.70	4.85	0.85	1420	5.50	4.68	0.85	1482
32	22	6.38	4.65	0.73	1357	6.15	4.49	0.73	1443	6.00	4.38	0.73	1482	5.75	4.20	0.73	1544
32	24	6.70	4.09	0.61	1420	6.45	3.93	0.61	1498	6.30	3.84	0.61	1544	6.10	3.72	0.61	1622
32	26	6.90	3.38	0.49	1498	6.70	3.28	0.49	1576	6.60	3.23	0.49	1622	6.40	3.14	0.49	1669

NOTE Q : Total capacity (kW) SHF : Sensible heat factor DB : Dry-bulb temperature
 SHC : Sensible heat capacity (kW) INPUT : Total power input (W) WB : Wet-bulb temperature

PERFORMANCE DATA COOL operation at Rated frequency
MUZ-EF50VE

CAPACITY: 5.0 kW SHF: 0.71 INPUT: 1560 W

INDOOR DB (°C)	INDOOR WB (°C)	OUTDOOR DB (°C)											
		35				40				46			
		Q	SHC	SHF	INPUT	Q	SHC	SHF	INPUT	Q	SHC	SHF	INPUT
21	18	4.90	2.60	0.53	1529	4.50	2.39	0.53	1622	4.15	2.20	0.53	1685
21	20	5.15	2.11	0.41	1591	4.80	1.97	0.41	1669	4.45	1.82	0.41	1763
22	18	4.90	2.79	0.57	1529	4.50	2.57	0.57	1622	4.15	2.37	0.57	1685
22	20	5.15	2.32	0.45	1591	4.80	2.16	0.45	1669	4.45	2.00	0.45	1763
22	22	5.45	1.80	0.33	1654	5.10	1.68	0.33	1747	4.75	1.57	0.33	1810
23	18	4.90	2.99	0.61	1529	4.50	2.75	0.61	1622	4.15	2.53	0.61	1685
23	20	5.15	2.52	0.49	1591	4.80	2.35	0.49	1669	4.45	2.18	0.49	1763
23	22	5.45	2.02	0.37	1654	5.10	1.89	0.37	1747	4.75	1.76	0.37	1810
24	18	4.90	3.19	0.65	1529	4.50	2.93	0.65	1622	4.15	2.70	0.65	1685
24	20	5.15	2.73	0.53	1591	4.80	2.54	0.53	1669	4.45	2.36	0.53	1763
24	22	5.45	2.23	0.41	1654	5.10	2.09	0.41	1747	4.75	1.95	0.41	1810
24	24	5.75	1.67	0.29	1716	5.40	1.57	0.29	1794	5.10	1.48	0.29	1872
25	18	4.90	3.38	0.69	1529	4.50	3.11	0.69	1622	4.15	2.86	0.69	1685
25	20	5.15	2.94	0.57	1591	4.80	2.74	0.57	1669	4.45	2.54	0.57	1763
25	22	5.45	2.45	0.45	1654	5.10	2.30	0.45	1747	4.75	2.14	0.45	1810
25	24	5.75	1.90	0.33	1716	5.40	1.78	0.33	1794	5.10	1.68	0.33	1872
26	18	4.90	3.58	0.73	1529	4.50	3.29	0.73	1622	4.15	3.03	0.73	1685
26	20	5.15	3.14	0.61	1591	4.80	2.93	0.61	1669	4.45	2.71	0.61	1763
26	22	5.45	2.67	0.49	1654	5.10	2.50	0.49	1747	4.75	2.33	0.49	1810
26	24	5.75	2.13	0.37	1716	5.40	2.00	0.37	1794	5.10	1.89	0.37	1872
26	26	6.05	1.51	0.25	1778	5.70	1.43	0.25	1856	5.35	1.34	0.25	1934
27	18	4.90	3.77	0.77	1529	4.50	3.47	0.77	1622	4.15	3.20	0.77	1685
27	20	5.15	3.35	0.65	1591	4.80	3.12	0.65	1669	4.45	2.89	0.65	1763
27	22	5.45	2.89	0.53	1654	5.10	2.70	0.53	1747	4.75	2.52	0.53	1810
27	24	5.75	2.36	0.41	1716	5.40	2.21	0.41	1794	5.10	2.09	0.41	1872
27	26	6.05	1.75	0.29	1778	5.70	1.65	0.29	1856	5.35	1.55	0.29	1934
28	18	4.90	3.97	0.81	1529	4.50	3.65	0.81	1622	4.15	3.36	0.81	1685
28	20	5.15	3.55	0.69	1591	4.80	3.31	0.69	1669	4.45	3.07	0.69	1763
28	22	5.45	3.11	0.57	1654	5.10	2.91	0.57	1747	4.75	2.71	0.57	1810
28	24	5.75	2.59	0.45	1716	5.40	2.43	0.45	1794	5.10	2.30	0.45	1872
28	26	6.05	2.00	0.33	1778	5.70	1.88	0.33	1856	5.35	1.77	0.33	1934
29	18	4.90	4.17	0.85	1529	4.50	3.83	0.85	1622	4.15	3.53	0.85	1685
29	20	5.15	3.76	0.73	1591	4.80	3.50	0.73	1669	4.45	3.25	0.73	1763
29	22	5.45	3.32	0.61	1654	5.10	3.11	0.61	1747	4.75	2.90	0.61	1810
29	24	5.75	2.82	0.49	1716	5.40	2.65	0.49	1794	5.10	2.50	0.49	1872
29	26	6.05	2.24	0.37	1778	5.70	2.11	0.37	1856	5.35	1.98	0.37	1934
30	18	4.90	4.36	0.89	1529	4.50	4.01	0.89	1622	4.15	3.69	0.89	1685
30	20	5.15	3.97	0.77	1591	4.80	3.70	0.77	1669	4.45	3.43	0.77	1763
30	22	5.45	3.54	0.65	1654	5.10	3.32	0.65	1747	4.75	3.09	0.65	1810
30	24	5.75	3.05	0.53	1716	5.40	2.86	0.53	1794	5.10	2.70	0.53	1872
30	26	6.05	2.48	0.41	1778	5.70	2.34	0.41	1856	5.35	2.19	0.41	1934
31	18	4.90	4.56	0.93	1529	4.50	4.19	0.93	1622	4.15	3.86	0.93	1685
31	20	5.15	4.17	0.81	1591	4.80	3.89	0.81	1669	4.45	3.60	0.81	1763
31	22	5.45	3.76	0.69	1654	5.10	3.52	0.69	1747	4.75	3.28	0.69	1810
31	24	5.75	3.28	0.57	1716	5.40	3.08	0.57	1794	5.10	2.91	0.57	1872
31	26	6.05	2.72	0.45	1778	5.70	2.57	0.45	1856	5.35	2.41	0.45	1934
32	18	4.90	4.75	0.97	1529	4.50	4.37	0.97	1622	4.15	4.03	0.97	1685
32	20	5.15	4.38	0.85	1591	4.80	4.08	0.85	1669	4.45	3.78	0.85	1763
32	22	5.45	3.98	0.73	1654	5.10	3.72	0.73	1747	4.75	3.47	0.73	1810
32	24	5.75	3.51	0.61	1716	5.40	3.29	0.61	1794	5.10	3.11	0.61	1872
32	26	6.05	2.96	0.49	1778	5.70	2.79	0.49	1856	5.35	2.62	0.49	1934

NOTE Q : Total capacity (kW) SHF : Sensible heat factor DB : Dry-bulb temperature
SHC : Sensible heat capacity (kW) INPUT : Total power input (W) WB : Wet-bulb temperature

PERFORMANCE DATA HEAT operation at Rated frequency
MUZ-EF25VE MUZ-EF25VEH

CAPACITY: 3.2 kW INPUT: 700 W

INDOOR DB (°C)	OUTDOOR WB (°C)													
	-10		-5		0		5		10		15		20	
	Q	INPUT	Q	INPUT	Q	INPUT	Q	INPUT	Q	INPUT	Q	INPUT	Q	INPUT
15	2.02	455	2.43	546	2.85	616	3.26	665	3.68	707	4.06	728	4.48	742
21	1.92	490	2.30	581	2.72	644	3.10	693	3.52	728	3.90	749	4.30	777
26	1.73	525	2.14	616	2.53	679	2.94	728	3.36	763	3.74	784	4.16	805

MUZ-EF35VE MUZ-EF35VEH

CAPACITY: 4.0 kW INPUT: 955 W

INDOOR DB (°C)	OUTDOOR WB (°C)													
	-10		-5		0		5		10		15		20	
	Q	INPUT	Q	INPUT	Q	INPUT	Q	INPUT	Q	INPUT	Q	INPUT	Q	INPUT
15	2.52	621	3.04	745	3.56	840	4.08	907	4.60	965	5.08	993	5.60	1012
21	2.40	669	2.88	793	3.40	879	3.88	945	4.40	993	4.88	1022	5.38	1060
26	2.16	716	2.68	840	3.16	926	3.68	993	4.20	1041	4.68	1070	5.20	1098

MUZ-EF42VE

CAPACITY: 5.4 kW INPUT: 1460 W

INDOOR DB (°C)	OUTDOOR WB (°C)													
	-10		-5		0		5		10		15		20	
	Q	INPUT	Q	INPUT	Q	INPUT	Q	INPUT	Q	INPUT	Q	INPUT	Q	INPUT
15	3.40	949	4.10	1139	4.81	1285	5.51	1387	6.21	1475	6.86	1518	7.56	1548
21	3.24	1022	3.89	1212	4.59	1343	5.24	1445	5.94	1518	6.59	1562	7.26	1621
26	2.92	1095	3.62	1285	4.27	1416	4.97	1518	5.67	1591	6.32	1635	7.02	1679

MUZ-EF50VE

CAPACITY: 5.8 kW INPUT: 1565 W

INDOOR DB (°C)	OUTDOOR WB (°C)													
	-10		-5		0		5		10		15		20	
	Q	INPUT	Q	INPUT	Q	INPUT	Q	INPUT	Q	INPUT	Q	INPUT	Q	INPUT
15	3.65	1017	4.41	1221	5.16	1377	5.92	1487	6.67	1581	7.37	1628	8.12	1659
21	3.48	1096	4.18	1299	4.93	1440	5.63	1549	6.38	1628	7.08	1675	7.80	1737
26	3.13	1174	3.89	1377	4.58	1518	5.34	1628	6.09	1706	6.79	1753	7.54	1800

NOTE: Q: Total capacity (kW) INPUT : Total power input (W) DB: Dry-bulb temperature WB: Wet-bulb temperature

MUZ-EF25VE MUZ-EF25VEH MUZ-EF35VE MUZ-EF35VEH MUZ-EF42VE MUZ-EF50VE

9-1. OUTDOOR FAN MOTOR CONTROL

The fan motor turns ON/OFF, interlocking with the compressor.

[ON] The fan motor turns ON 5 seconds before the compressor starts up.

[OFF] The fan motor turns OFF 15 seconds after the compressor has stopped running.

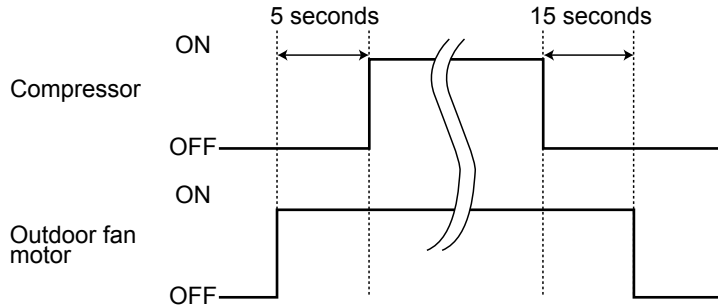

9-2. R.V. COIL CONTROL

Heating ON

Cooling OFF

Dry OFF

NOTE: The 4-way valve reverses for 5 seconds right before start-up of the compressor.

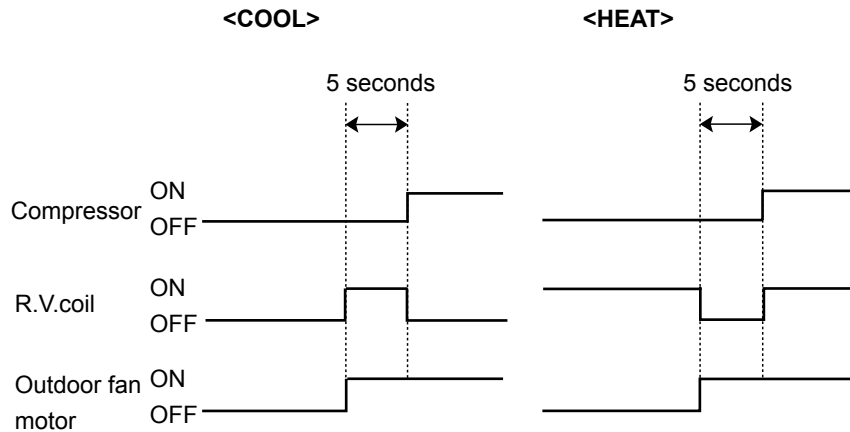

9-3. RELATION BETWEEN MAIN SENSOR AND ACTUATOR

Sensor	Purpose	Actuator					
		Compressor	LEV	Outdoor fan motor	R.V.coil	Indoor fan motor	Defrost heater
Discharge temperature thermistor	Protection	○	○				
Indoor coil temperature thermistor	Cooling: Coil frost prevention	○					
	Heating: High pressure protection	○	○				
Defrost thermistor	Heating: Defrosting	○	○	○	○	○	
Fin temperature thermistor	Protection	○		○			
Ambient temperature thermistor	Cooling: Low ambient temperature operation	○	○	○			
	Heating: Defrosting (Heater)						○
Outdoor heat exchanger temperature thermistor	Cooling: Low ambient temperature operation	○	○	○			
	Cooling: High pressure protection	○	○	○			

10

SERVICE FUNCTIONS

MUZ-EF25VE MUZ-EF25VEH MUZ-EF35VE MUZ-EF35VEH MUZ-EF42VE MUZ-EF50VE

10-1. CHANGE IN DEFROST SETTING

Changing defrost finish temperature

<JS> To change the defrost finish temperature, cut/solder the JS wire of the outdoor inverter P.C. board. (Refer to 11-6-1.)

Jumper wire		Defrost finish temperature (°C)	
		MUZ-EF25/35/42	MUZ-EF50
JS	Soldered (Initial setting)	5	9
	None (Cut)	10	18

10-2. PRE-HEAT CONTROL SETTING

PRE-HEAT CONTROL

When moisture gets into the refrigerant cycle, it may interfere the start-up of the compressor at low outside temperature. The pre-heat control prevents this interference. The pre-heat control turns ON when the defrost thermistor reads 20°C or below. When pre-heat control is turned ON, compressor is energized. (About 50 W)

<JK> To activate the pre-heat control, cut the JK wire of the inverter P.C. board. (Refer to 11-6.1)

NOTE: When the inverter P.C. board is replaced, check the Jumper wires, and cut/solder them if necessary.

11

TROUBLESHOOTING

MUZ-EF25VE MUZ-EF25VEH MUZ-EF35VE MUZ-EF35VEH MUZ-EF42VE MUZ-EF50VE

11-1. CAUTIONS ON TROUBLESHOOTING

1. Before troubleshooting, check the following

- 1) Check the power supply voltage.
- 2) Check the indoor/outdoor connecting wire for miswiring.

2. Take care of the following during servicing

- 1) Before servicing the air conditioner, be sure to turn OFF the main unit first with the remote controller, and then after confirming the horizontal vane is closed, turn OFF the breaker and/or disconnect the power plug.
- 2) Be sure to turn OFF the power supply before removing the front panel, the cabinet, the top panel, and the electronic control P.C. board.
- 3) When removing the electrical parts, be careful of the residual voltage of smoothing capacitor.
- 4) When removing the electronic control P.C. board, hold the edge of the board with care NOT to apply stress on the components.
- 5) When connecting or disconnecting the connectors, hold the housing of the connector. DO NOT pull the lead wires.

<Incorrect>

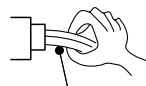

Lead wiring

<Correct>

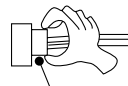

Housing point

3. Troubleshooting procedure

- 1) First, check if the OPERATION INDICATOR lamp on the indoor unit is flashing on and off to indicate an abnormality. To make sure, check how many times the OPERATION INDICATOR lamp is flashing on and off before starting service work.
- 2) Before servicing, check that the connector and terminal are connected properly.
- 3) When the electronic control P.C. board seems to be defective, check the copper foil pattern for disconnection and the components for bursting and discoloration.
- 4) Refer to 11-2 and 11-3.

11-2. FAILURE MODE RECALL FUNCTION

Outline of the function

This air conditioner can memorize the abnormal condition which has occurred once.

Even though LED indication listed on the troubleshooting check table (11-3.) disappears, the memorized failure details can be recalled.

1. Flow chart of failure mode recall function for the indoor/outdoor unit

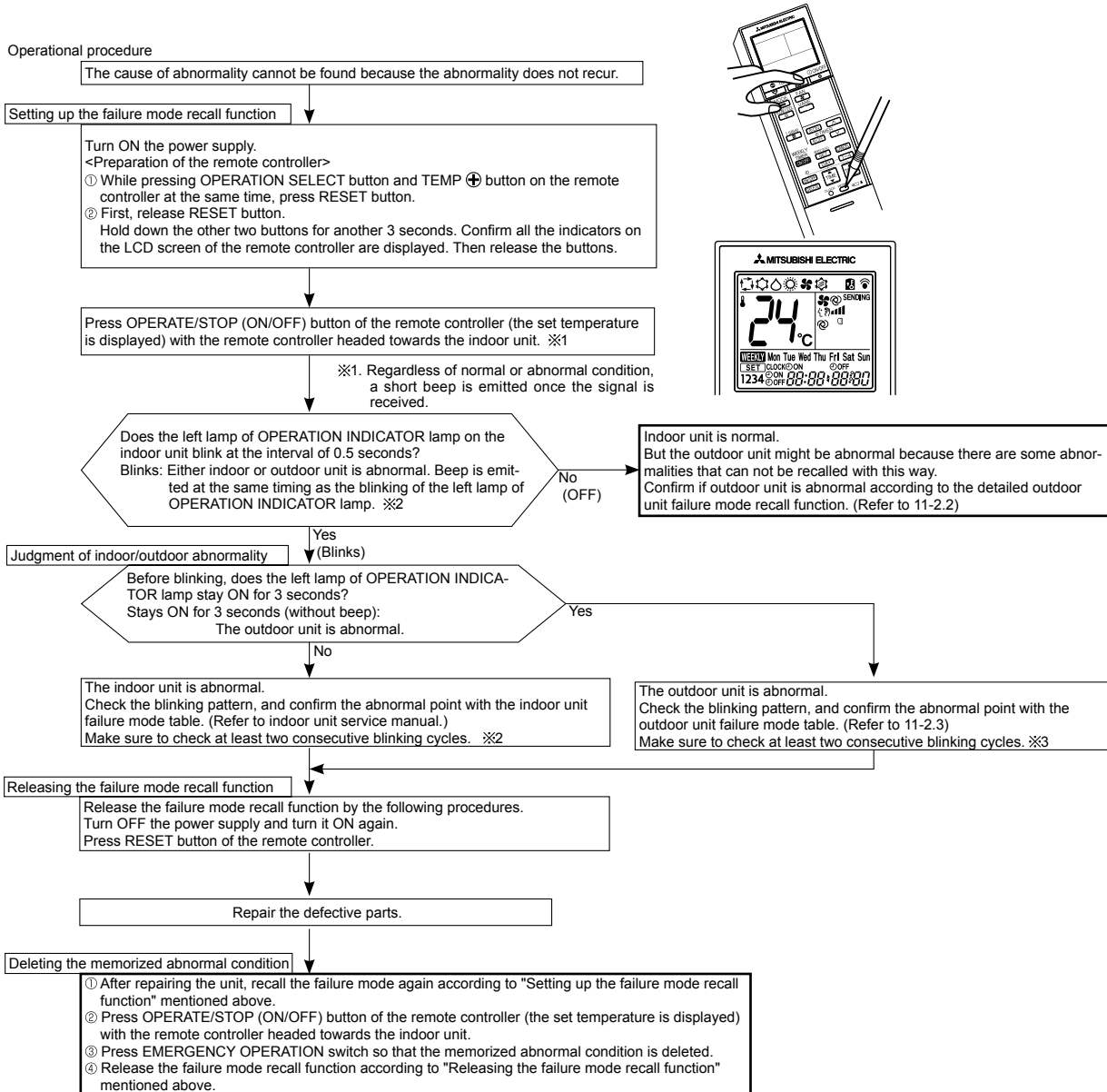

NOTE: 1. Make sure to release the failure mode recall function once it is set up, otherwise the unit cannot operate properly.
2. If the abnormal condition is not deleted from the memory, the last abnormal condition is kept memorized.

※2. Blinking pattern when the indoor unit is abnormal:

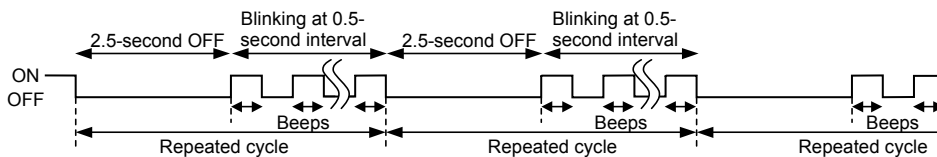

※3. Blinking pattern when the outdoor unit is abnormal:

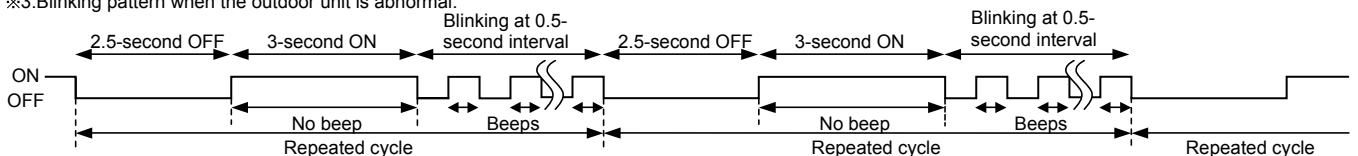

2. Flow chart of the detailed outdoor unit failure mode recall function

Operational procedure

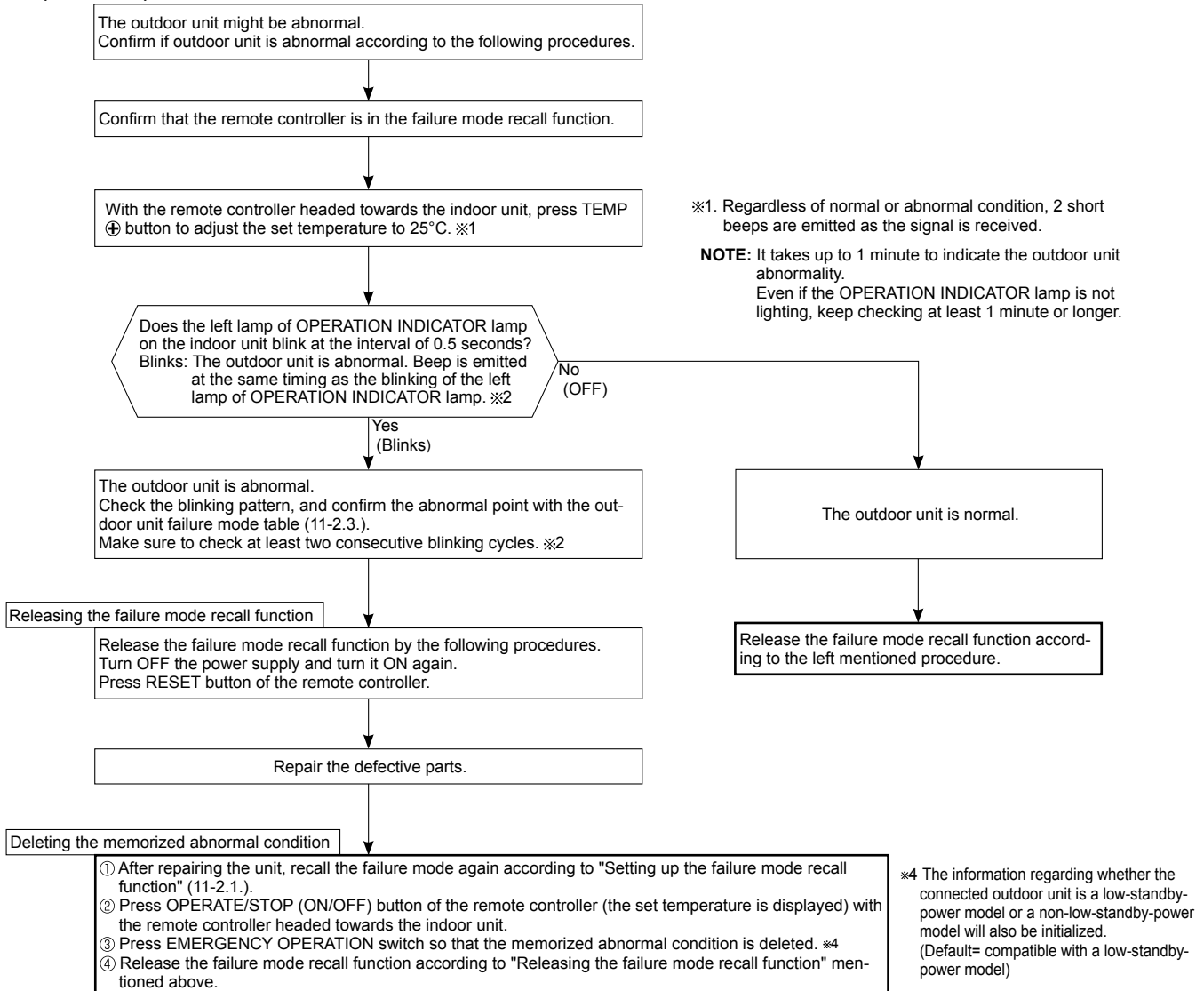

NOTE: 1. Make sure to release the failure mode recall function once it is set up, otherwise the unit cannot operate properly.
2. If the abnormal condition is not deleted from the memory, the last abnormal condition is kept memorized.

※2. Blinking pattern when outdoor unit is abnormal:

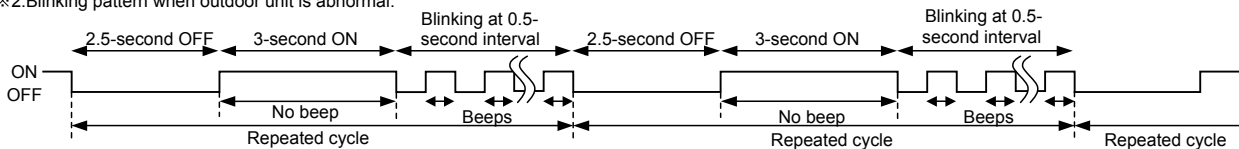

3. Outdoor unit failure mode table

The left lamp of OPERATION INDICATOR lamp (Indoor unit)	Abnormal point (Failure mode/protection)	LED indication (Outdoor P.C. board)	Condition	Remedy	Indoor/outdoor unit failure mode recall function	Outdoor unit failure mode recall function
OFF	None (Normal)	—	—	—	—	—
1-time flash 2.5 seconds OFF	Indoor/outdoor communication, receiving error	—	Any signals from the inverter P.C. board cannot be received normally for 3 minutes.	•Refer to 11-5. ㉔ How to check miswiring and serial signal error.	○	○
	Indoor/outdoor communication, receiving error	—	Although the inverter P.C. board sends signal "0", signal "1" has been received 30 consecutive times.	•Refer to 11-5. ㉔ How to check miswiring and serial signal error.		
2-time flash 2.5 seconds OFF	Outdoor power system	—	Overcurrent protection cut-out operates 3 consecutive times within 1 minute after the compressor gets started.	•Reconnect connectors. •Refer to 11-5. ㉔ How to check inverter/compressor". •Check stop valve.	○	○
3-time flash 2.5 seconds OFF	Discharge temperature thermistor	1-time flash every 2.5 seconds	Thermistor shorts or opens during compressor running.	•Refer to 11-5. ㉔ "Check of outdoor thermistors". Defective outdoor thermistors can be identified by checking the blinking pattern of LED.	○	○
	Defrost thermistor					
	Fin temperature thermistor	3-time flash 2.5 seconds OFF				
	P.C. board temperature thermistor	4-time flash 2.5 seconds OFF				
	Ambient temperature thermistor	2-time flash 2.5 seconds OFF				
	Outdoor heat exchanger temperature thermistor	—				
4-time flash 2.5 seconds OFF	Overcurrent	11-time flash 2.5 seconds OFF	Large current flows into intelligent power module.	•Reconnect compressor connector. •Refer to 11-5. ㉔ How to check inverter/compressor". •Check stop valve.	—	○
	Compressor synchronous abnormality (Compressor start-up failure protection)	12-time flash 2.5 seconds OFF	Waveform of compressor current is distorted.	•Reconnect compressor connector. •Refer to 11-5. ㉔ How to check inverter/compressor".	—	○
5-time flash 2.5 seconds OFF	Discharge temperature	—	Temperature of discharge temperature thermistor exceeds 116°C, compressor stops. Compressor can restart if discharge temperature thermistor reads 100°C or less 3 minutes later.	•Check refrigerant circuit and refrigerant amount. •Refer to 11-5. ㉔ Check of LEV".	—	○
6-time flash 2.5 seconds OFF	High pressure	—	Temperature indoor coil thermistor exceeds 70°C in HEAT mode. Temperature defrost thermistor exceeds 70°C in COOL mode.	•Check refrigerant circuit and refrigerant amount. •Check stop valve.	—	○
7-time flash 2.5 seconds OFF	Fin temperature/ P.C. board temperature	7-time flash 2.5 seconds OFF	Temperature of fin temperature thermistor on the inverter P.C. board exceeds 75 ~ 86°C, or temperature of P.C. board temperature thermistor on the inverter P.C. board exceeds 72 ~ 85°C.	•Check around outdoor unit. •Check outdoor unit air passage. •Refer to 11-5. ㉔ Check of outdoor fan motor".	—	○
8-time flash 2.5 seconds OFF	Outdoor fan motor	—	Outdoor fan has stopped 3 times in a row within 30 seconds after outdoor fan start-up.	•Refer to 11-5. ㉔ Check of outdoor fan motor". Refer to 11-5. ㉔ Check of inverter P.C. board".	—	○
9-time flash 2.5 seconds OFF	Nonvolatile memory data	5-time flash 2.5 seconds OFF	Nonvolatile memory data cannot be read properly.	•Replace the inverter P.C. board.	○	○
	Power module	6-time flash 2.5 seconds OFF	The interface short circuit occurs in the output of the intelligent power module (IC700). The compressor winding shorts circuit.	•Refer to 11-5. ㉔ How to check inverter/compressor".		
10-time flash 2.5 seconds OFF	Discharge temperature	—	Temperature of discharge temperature thermistor has been 50°C or less for 20 minutes.	•Refer to 11-5. ㉔ Check of LEV". •Check refrigerant circuit and refrigerant amount.	—	○
11-time flash 2.5 seconds OFF	DC voltage	8-time flash 2.5 seconds OFF	DC voltage of inverter cannot be detected normally.	•Refer to 11-5. ㉔ How to check inverter/compressor".	—	○
	Each phase current of compressor	9-time flash 2.5 seconds OFF	Each phase current of compressor cannot be detected normally.			
14-time flash 2.5 seconds OFF	Stop valve (Closed valve)	14-time flash 2.5 seconds OFF	Closed valve is detected by compressor current.	•Check stop valve	○	○

NOTE: Blinking patterns of this mode differ from the ones of Troubleshooting check table (11-3.).

11-3. TROUBLESHOOTING CHECK TABLE

No.	Symptom	LED indication	Abnormal point/ Condition	Condition	Remedy	
1	Outdoor unit does not operate.	1-time flash every 2.5 seconds	Outdoor power system	Overcurrent protection cut-out operates 3 consecutive times within 1 minute after the compressor gets started.	<ul style="list-style-type: none"> •Reconnect connector of compressor. •Refer to 11-5.Ⓐ "How to check inverter/compressor". •Check stop valve. 	
2			Outdoor thermistors	Discharge temperature thermistor, fin temperature thermistor, defrost thermistor, P.C. board temperature thermistor, outdoor heat exchanger temperature thermistor or ambient temperature thermistor shorts or opens during compressor running.	•Refer to 11-5.Ⓒ "Check of outdoor thermistors".	
3			Outdoor control system	Nonvolatile memory data cannot be read properly. (The left lamp of OPERATION INDICATOR lamp of the indoor unit lights up or flashes 7-time.)	•Replace inverter P.C. board.	
4		6-time flash 2.5 seconds OFF	Serial signal	The communication fails between the indoor and outdoor unit for 3 minutes.	•Refer to 11-5.Ⓜ "How to check miswiring and serial signal error.	
5		11-time flash 2.5 seconds OFF	Stop valve/ Closed valve	Closed valve is detected by compressor current.	•Check stop valve.	
6		14-time flash 2.5 seconds OFF	Outdoor unit (Other abnormality)	Outdoor unit is defective.	•Refer to 11-2.2. "Flow chart of the detailed outdoor unit failure mode recall function".	
7	'Outdoor unit stops and restarts 3 minutes later' is repeated.	2-time flash 2.5 seconds OFF	Overcurrent protection	Large current flows into intelligent power module.	<ul style="list-style-type: none"> •Reconnect connector of compressor. •Refer to 11-5.Ⓐ "How to check inverter/compressor". •Check stop valve. 	
8		3-time flash 2.5 seconds OFF	Discharge temperature overheat protection	Temperature of discharge temperature thermistor exceeds 116°C, compressor stops. Compressor can restart if discharge temperature thermistor reads 100°C or less 3 minutes later.	<ul style="list-style-type: none"> •Check refrigerant circuit and refrigerant amount. •Refer to 11-5.ⓧ "Check of LEV". 	
9		4-time flash 2.5 seconds OFF	Fin temperature /P.C. board temperature thermistor overheat protection	Temperature of fin temperature thermistor on the heat sink exceeds 75 ~ 86°C or temperature of P.C. board temperature thermistor on the inverter P.C. board exceeds 72 ~ 85°C.	<ul style="list-style-type: none"> •Check around outdoor unit. •Check outdoor unit air passage. •Refer to 11-5.Ⓛ "Check of outdoor fan motor". 	
10		5-time flash 2.5 seconds OFF	High pressure protection	Indoor coil thermistor exceeds 70°C in HEAT mode. Defrost thermistor exceeds 70°C in COOL mode.	<ul style="list-style-type: none"> •Check refrigerant circuit and refrigerant amount. •Check stop valve. 	
11		8-time flash 2.5 seconds OFF	Compressor synchronous abnormality	The waveform of compressor current is distorted.	<ul style="list-style-type: none"> •Reconnect connector of compressor. •Refer to 11-5.Ⓐ "How to check inverter/compressor". 	
12		10-time flash 2.5 seconds OFF	Outdoor fan motor	Outdoor fan has stopped 3 times in a row within 30 seconds after outdoor fan start-up.	<ul style="list-style-type: none"> •Refer to 11-5.Ⓛ "Check of outdoor fan motor. •Refer to 11-5.Ⓛ "Check of inverter P.C. board. 	
13		12-time flash 2.5 seconds OFF	Each phase current of compressor	Each phase current of compressor cannot be detected normally.	•Refer to 11-5.Ⓐ "How to check inverter/compressor".	
14		13-time flash 2.5 seconds OFF	DC voltage	DC voltage of inverter cannot be detected normally.	•Refer to 11-5.Ⓐ "How to check inverter/compressor".	
15		Outdoor unit operates.	1-time flash 2.5 seconds OFF	Frequency drop by current protection	When the input current exceeds approximately 7A(EF25)/8A(EF35)/9A(EF42)/12A(EF50), compressor frequency lowers.	The unit is normal, but check the following.
16			3-time flash 2.5 seconds OFF	Frequency drop by high pressure protection	Temperature of indoor coil thermistor exceeds 55°C in HEAT mode, compressor frequency lowers.	<ul style="list-style-type: none"> •Check if indoor filters are clogged. •Check if refrigerant is short. •Check if indoor/outdoor unit air circulation is short cycled.
17	Frequency drop by defrosting in COOL mode			Indoor coil thermistor reads 8°C or less in COOL mode, compressor frequency lowers.		
18	4-time flash 2.5 seconds OFF		Frequency drop by discharge temperature protection	Temperature of discharge temperature thermistor exceeds 111°C, compressor frequency lowers.	<ul style="list-style-type: none"> •Check refrigerant circuit and refrigerant amount. •Refer to 11-5.ⓧ "Check of LEV". •Refer to 11-5.Ⓒ "Check of outdoor thermistors". 	
19	Outdoor unit operates.	5-time flash 2.5 seconds OFF	Outside temperature thermistor protection	When the outside temperature thermistor shorts or opens, protective operation without that thermistor is performed.	•Refer to 11-5.Ⓒ Check of outdoor thermistors.	
20		7-time flash 2.5 seconds OFF	Low discharge temperature protection	Temperature of discharge temperature thermistor has been 50°C or less for 20 minutes.	<ul style="list-style-type: none"> •Refer to 11-5.ⓧ "Check of LEV". •Check refrigerant circuit and refrigerant amount. 	
21		8-time flash 2.5 seconds OFF	PAM protection PAM: Pulse Amplitude Modulation	The overcurrent flows into PFC (Power factor correction : IC820) or the bus-bar voltage reaches 394 V or more, PAM stops and restarts.	This is not malfunction. PAM protection will be activated in the following cases: 1 Instantaneous power voltage drop. (Short time power failure) 2 When the power supply voltage is high.	
21	9-time flash 2.5 seconds OFF	Inverter check mode	The connector of compressor is disconnected, inverter check mode starts.	•Check if the connector of the compressor is correctly connected. Refer to 11-5.Ⓐ "How to check inverter/compressor".		

NOTE: 1. The location of LED is illustrated at the right figure. Refer to 11-6.1.
2. LED is lighted during normal operation.

Inverter P.C. board

The flashing frequency shows the number of times the LED blinks after every 2.5-second OFF.
(Example) When the flashing frequency is "2".

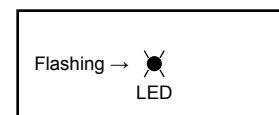
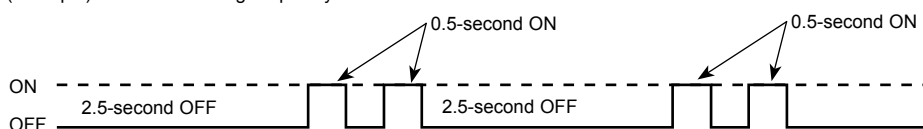

11-4. TROUBLE CRITERION OF MAIN PARTS

MUZ-EF25VE MUZ-EF25VEH MUZ-EF35VE MUZ-EF35VEH MUZ-EF42VE MUZ-EF50VE

Part name	Check method and criterion	Figure
Defrost thermistor (RT61) Fin temperature thermistor (RT64) Ambient temperature thermistor (RT65) Outdoor heat exchanger temperature thermistor (RT68)	Measure the resistance with a tester. Refer to 11-6. "Test point diagram and voltage", 1. "Inverter P.C. board", for the chart of thermistor.	
Discharge temperature thermistor (RT62)	Measure the resistance with a tester. Before measurement, hold the thermistor with your hands to warm it up. Refer to 11-6. "Test point diagram and voltage", 1. "Inverter P.C. board", for the chart of thermistor.	
Compressor	Measure the resistance between terminals using a tester. (Temperature: -10 ~ 40°C)	
Outdoor fan motor	Measure the resistance between lead wires using a tester. (Temperature: -10 ~ 40°C)	
R. V. coil (21S4)	Measure the resistance using a tester. (Temperature: -10 ~ 40°C)	
Expansion valve coil (LEV)	Measure the resistance using a tester. (Temperature: -10 ~ 40°C) MUZ-EF25/35/42	
	Measure the resistance using a tester. (Temperature: -10 ~ 40°C) MUZ-EF50	
Defrost heater MUZ-EF-VEH	Measure the resistance using a tester. (Temperature: -10 ~ 40°C)	

11-5. TROUBLESHOOTING FLOW

A How to check inverter/compressor

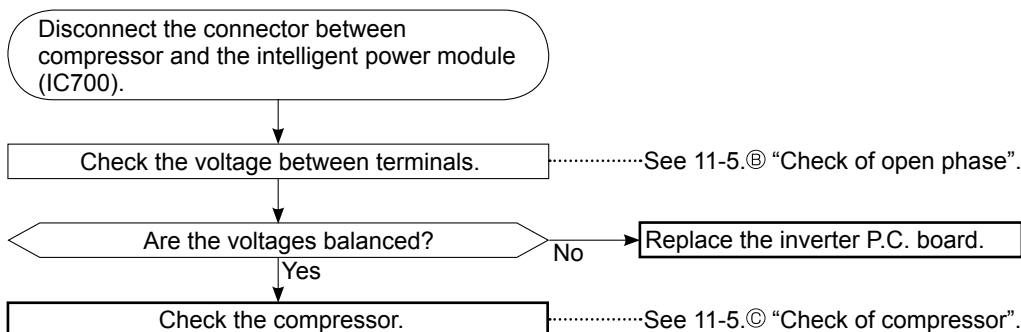

B Check of open phase

- With the connector between the compressor and the intelligent power module disconnected, activate the inverter and check if the inverter is normal by measuring the **voltage balance** between the terminals.

Output voltage is 50 - 130 V. (The voltage may differ according to the tester.)

<< Operation method >>

Start cooling or heating operation by pressing EMERGENCY OPERATION switch on the indoor unit. (TEST RUN OPERATION: Refer to 8-3.)

<< Measurement point >>

At 3 points

BLK (U)-WHT (V)

※ Measure AC voltage between the lead wires at 3 points.

BLK (U)-RED (W)

WHT(V)-RED (W)

- NOTE:**
1. Output voltage varies according to power supply voltage.
 2. Measure the voltage by analog type tester.
 3. During this check, LED of the inverter P.C. board flashes 9 times. (Refer to 11-6.1.)

C Check of compressor

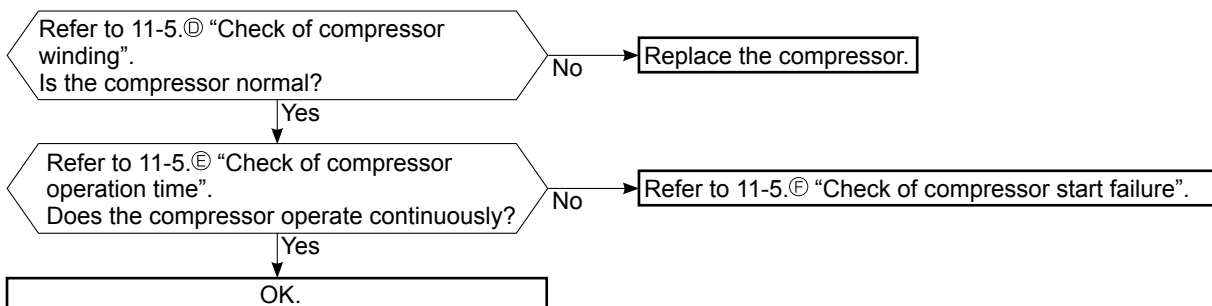

D Check of compressor winding

- Disconnect the connector between the compressor and intelligent power module, and measure the resistance between the compressor terminals.

<<Measurement point>>

at 3 points

BLK-WHT

BLK-RED

WHT-RED

※ Measure the resistance between the lead wires at 3 points.

<<Judgement>>

Refer to 11-4.

0 [Ω]Abnormal [short]

Infinite [Ω]Abnormal [open]

NOTE: Be sure to zero the ohmmeter before measurement.

E Check of compressor operation time

- Connect the compressor and activate the inverter. Then measure the time until the inverter stops due to over current.

<<Operation method>>

Start heating or cooling operation by pressing EMERGENCY OPERATION switch on the indoor unit. (TEST RUN OPERATION: Refer to 8-3.)

<<Measurement>>

Measure the time from the start of compressor to the stop of compressor due to overcurrent.

<<Judgement>>

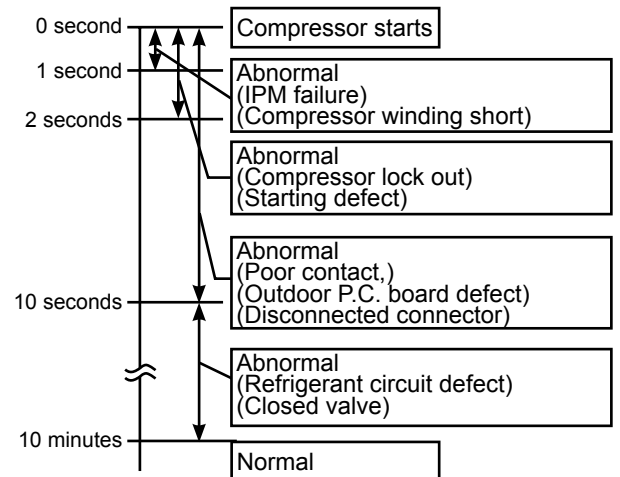

F Check of compressor start failure

Confirm that ①~④ is normal.

•Electrical circuit check

①. Contact of the compressor connector

②. Output voltage of inverter P.C. board and balance of them (See 11-5.⑥)

③. Direct current voltage between DB61(+) and (-) on the inverter P.C. board

④. Voltage between outdoor terminal block S1-S2

Does the compressor run for 10 seconds or more after it starts?

Yes

Check the refrigerant circuit.
Check the stop valve.

No

After the compressor is heated with a drier, does the compressor start? ※1

No

Replace the compressor.

Yes

Compressor start failure. Activate pre-heat control.
(Refer to 10-2. "PRE-HEAT CONTROL SETTING")

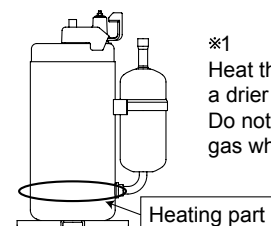

※1

Heat the compressor with a drier for about 20 minutes. Do not recover refrigerant gas while heating.

G Check of outdoor thermistors

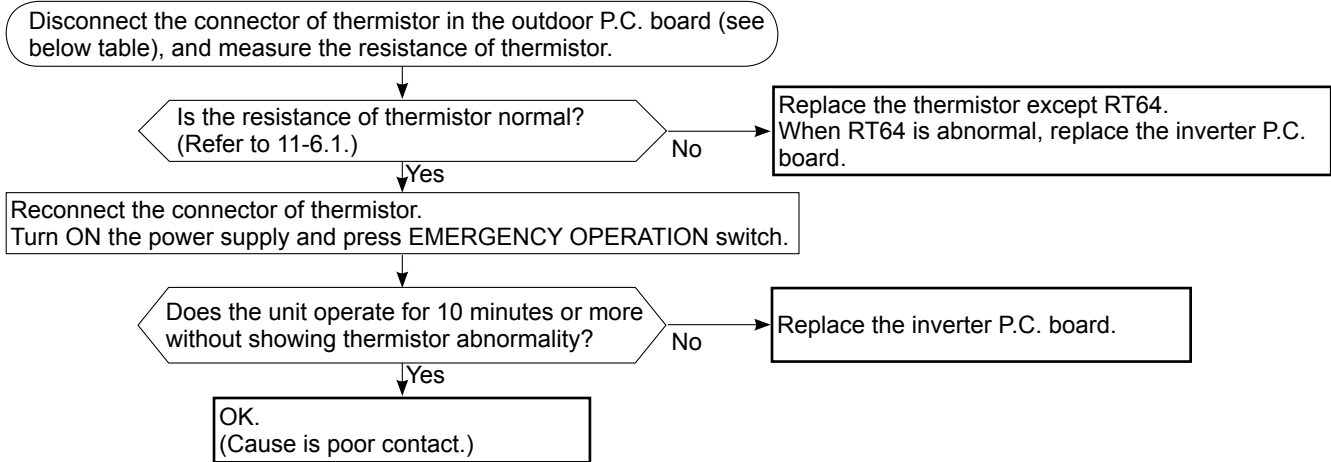

Thermistor	Symbol	Connector, Pin No.	Board
Defrost	RT61	Between CN641 pin1 and pin2	Inverter P.C. board
Discharge temperature	RT62	Between CN641 pin3 and pin4	
Fin temperature	RT64	Between CN642 pin1 and pin2	
Ambient temperature	RT65	Between CN643 pin1 and pin2	
Outdoor heat exchanger temperature	RT68	Between CN644 pin1 and pin3	

H Check of R.V. coil

- ※ First of all, measure the resistance of R.V. coil to check if the coil is defective. Refer to 11-4.
- ※ In case CN721 is disconnected or R.V. coil is open, voltage is generated between the terminal pins of the connector although no signal is being transmitted to R.V. coil. Check if CN721 is connected.

Unit operates COOL mode even if it is set to HEAT mode.

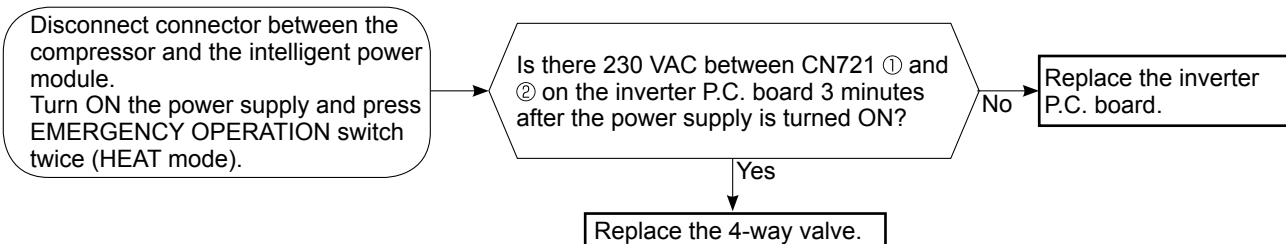

Unit operates HEAT mode even if it is set to COOL mode.

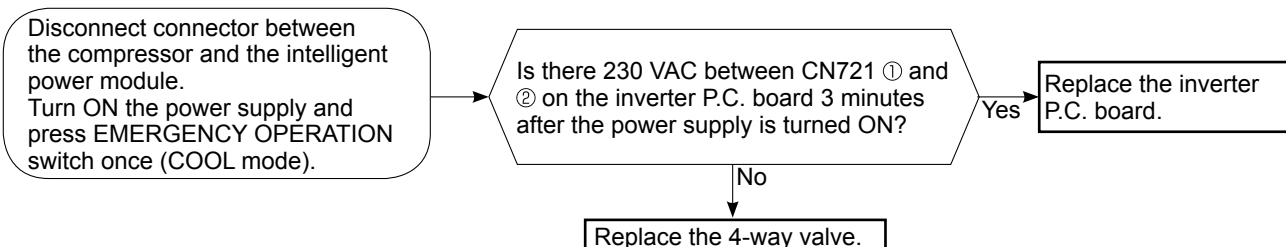

① Check of outdoor fan motor

Disconnect the connectors CN931 and CN932 from the inverter P.C. board.
Check the connection between the connector CN931 and CN932.

Is the resistance between each terminal of outdoor fan motor normal?
(Refer to 11-4.)

Yes

Disconnect CN932 from the inverter P.C. board, and turn on the power supply.

Rotate the outdoor fan motor manually and measure the voltage of CN931.
Between 1(+) and 5(-)
Between 2(+) and 5(-)
Between 3(+) and 5(-)

No

(Fixed to either 5 or 0 VDC)
Does the voltage between each terminal become 5 and 0 VDC repeatedly?

No

Yes

Does the outdoor fan motor rotate smoothly?

No

Yes

Replace the outdoor fan motor.

Replace the inverter P.C. board.

J Check of power supply

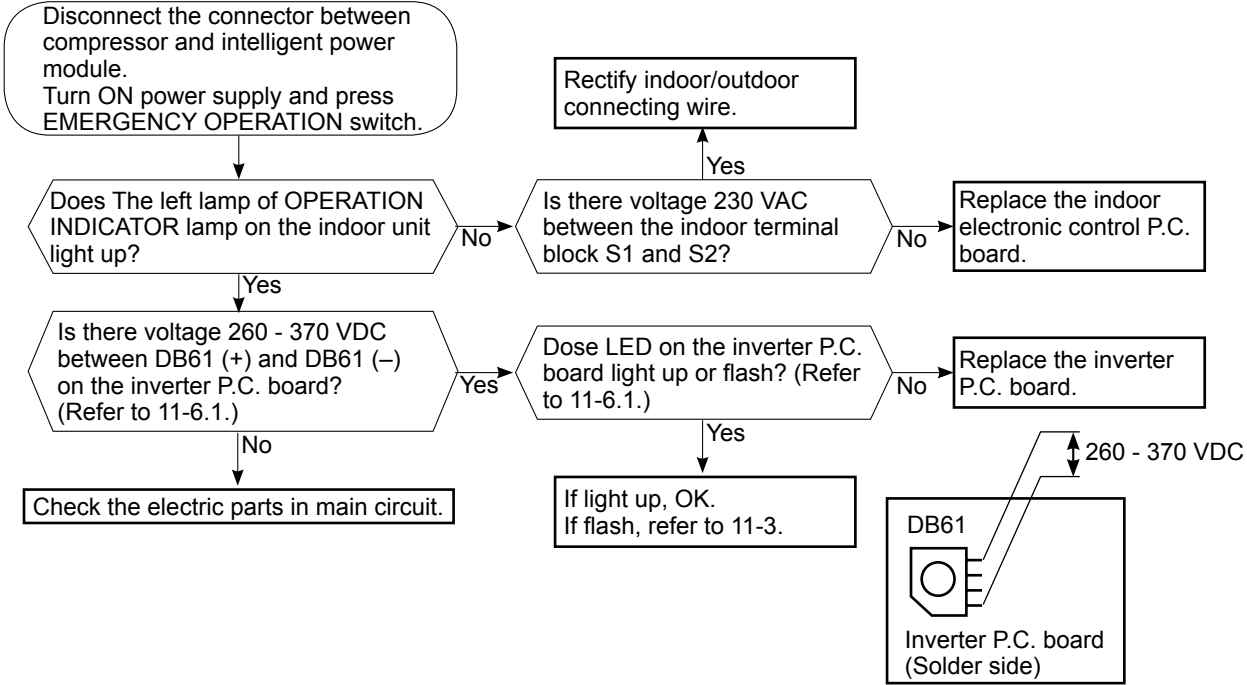

K Check of LEV (Expansion valve)

Turn ON the power supply.
 <Preparation of the remote controller>
 ① While pressing both OPERATION SELECT button and TEMP \oplus button on the remote controller at the same time, press RESET button.
 ② First, release RESET button.
 Hold down the other two buttons for another 3 seconds. Confirm all the indicators except the set temperature on the LCD screen of the remote controller are displayed. Then release the buttons.

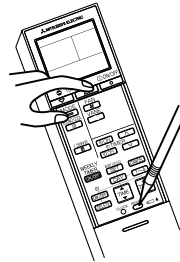

Press OPERATE/STOP (ON/OFF) button of the remote controller (the set temperature is displayed) with the remote controller headed towards the indoor unit. ※1

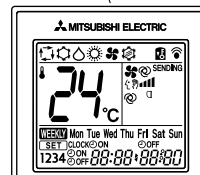

Expansion valve operates in full-opening direction.

Do you hear the expansion valve "click, click....." ?
 Do you feel the expansion valve vibrate on touching it ?

Yes

OK

No

Is LEV coil properly fixed to the expansion valve?

No

Properly fix the LEV coil to the expansion valve.

Yes

Does the resistance of LEV coil have the characteristics? (Refer to 11-4.)

Yes

Measure each voltage between connector pins of CN724 on the inverter P.C. board.
 1. Pin③(-) — Pin①(+)
 2. Pin④(-) — Pin①(+)
 3. Pin⑤(-) — Pin①(+)
 4. Pin⑥(-) — Pin①(+)
 Is there about 3 - 5 VAC between each?
NOTE: Measure the voltage by an analog tester.

No

Replace the inverter P.C. board.

Replace the LEV coil.

Yes

Replace the expansion valve.

※1. Regardless of normal or abnormal condition, a short beep is emitted once the signal is received.

NOTE: After check of LEV, do the undermentioned operations.

1. Turn OFF the power supply and turn it ON again.
2. Press RESET button on the remote controller.

Ⓛ Check of inverter P.C. board

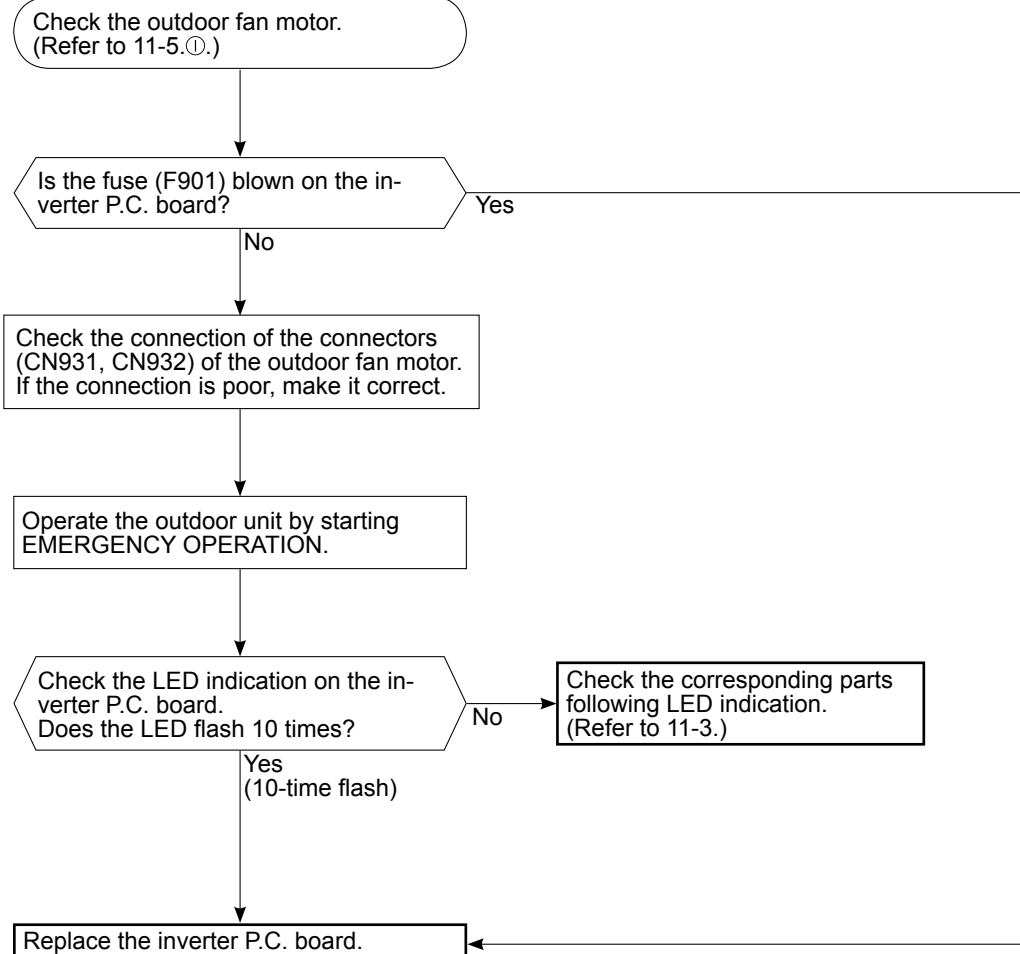

M How to check miswiring and serial signal error

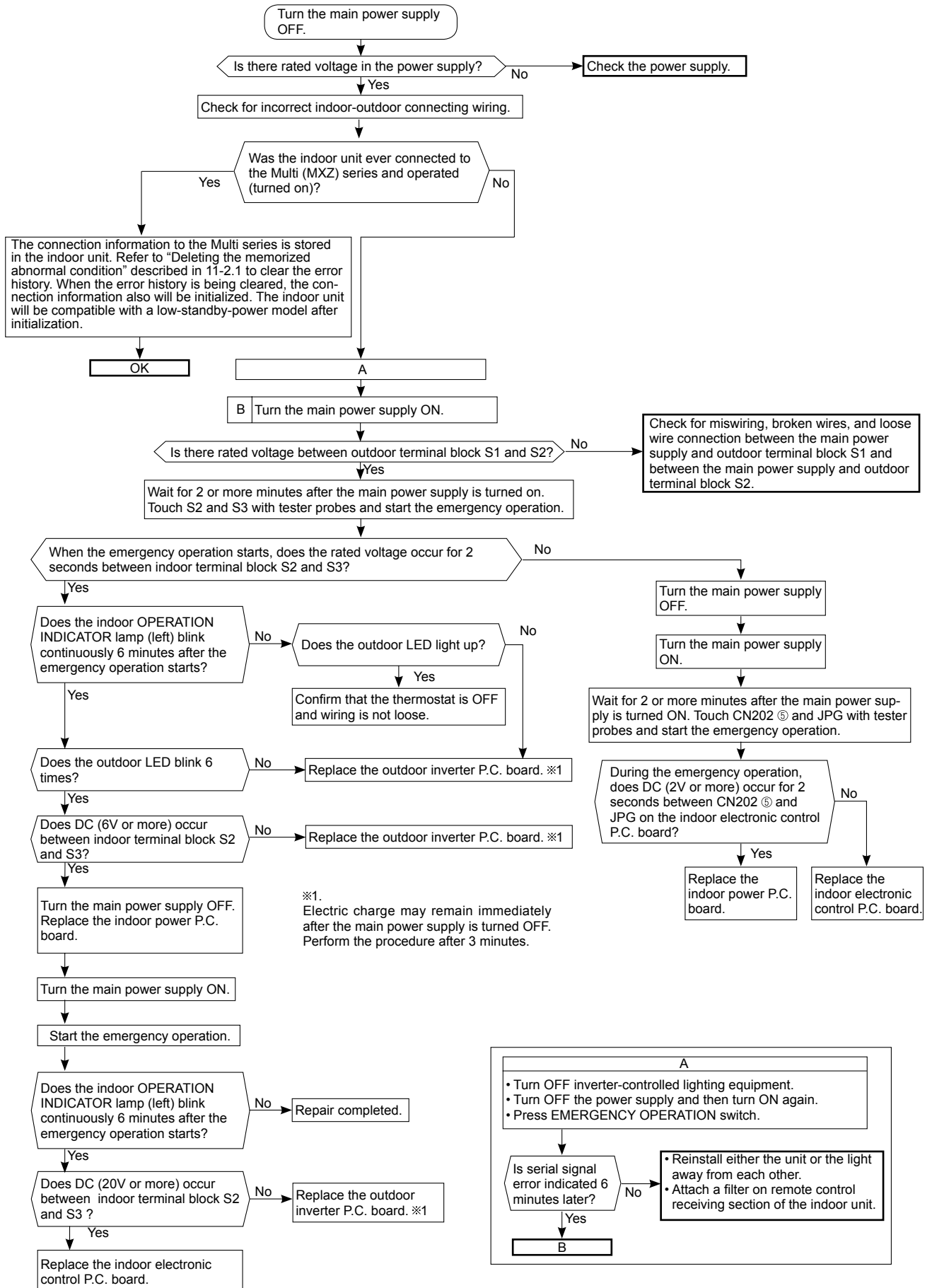

Ⓝ Electromagnetic noise enters into TV sets or radios

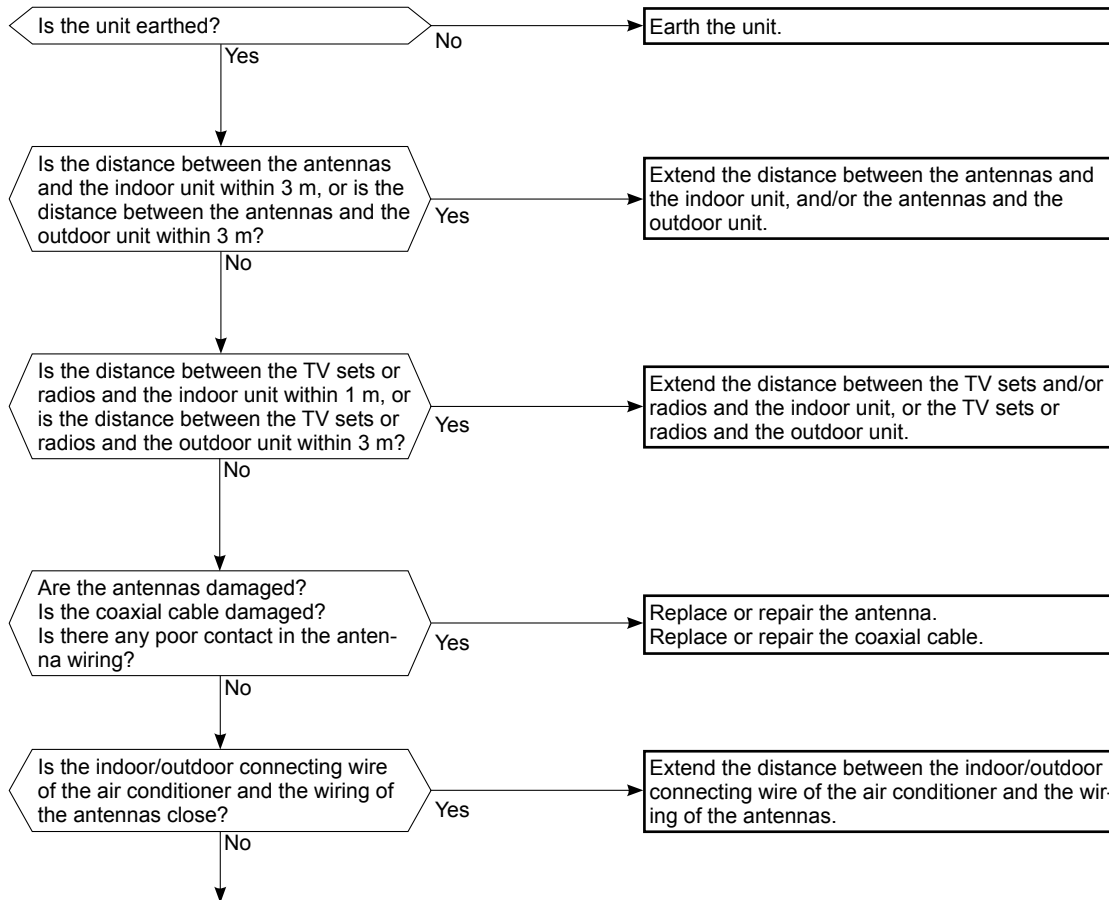

Even if all of the above conditions are fulfilled, the electromagnetic noise may enter, depending on the electric field strength or the installation condition (combination of specific conditions such as antennas or wiring). Check the following before asking for service.

1. Devices affected by the electromagnetic noise
TV sets, radios (FM/AM broadcast, shortwave)
2. Channel, frequency, broadcast station affected by the electromagnetic noise
3. Channel, frequency, broadcast station unaffected by the electromagnetic noise
4. Layout of:
indoor/outdoor unit of the air conditioner, indoor/outdoor wiring, earth wire, antennas, wiring from antennas, receiver
5. Electric field intensity of the broadcast station affected by the electromagnetic noise
6. Presence or absence of amplifier such as booster
7. Operation condition of air conditioner when the electromagnetic noise enters in
 - 1) Turn OFF the power supply once, and then turn ON the power supply. In this situation, check for the electromagnetic noise.
 - 2) Within 3 minutes after turning ON the power supply, press OPERATE/STOP (ON/OFF) button on the remote controller for power ON, and check for the electromagnetic noise.
 - 3) After a short time (3 minutes later after turning ON), the outdoor unit starts running. During operation, check for the electromagnetic noise.
 - 4) Press OPERATE/STOP (ON/OFF) button on the remote controller for power OFF, when the outdoor unit stops but the indoor/outdoor communication still runs on. In this situation, check for the electromagnetic noise.



⊙ Check of defrost heater

MUZ-EF•VEH

Check the following points before checking electric continuity.

- 1. Does the resistance of ambient temperature thermistor have the characteristics? Refer to 11-6.1.
- 2. Is the resistance of defrost heater normal? Refer to 11-4.
- 3. Does the heater protector remain conducted (not open)?
- 4. Are both ambient temperature thermistor and circuit of defrost heater securely connected to connectors?

In HEAT mode, for more than 5 minutes, let the ambient temperature thermistor continue to read 5°C or below, and let the defrost thermistor continue to read -1°C or below.

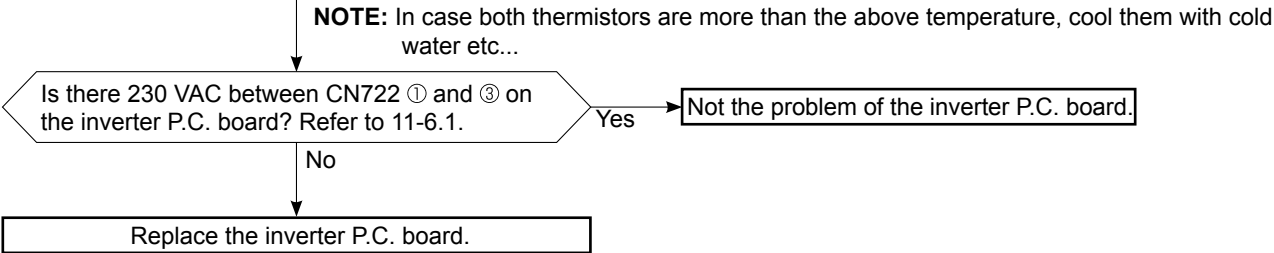

11-6. TEST POINT DIAGRAM AND VOLTAGE

1. Inverter P.C. board

MUZ-EF25VE MUZ-EF25VEH MUZ-EF35VE MUZ-EF35VEH MUZ-EF42VE MUZ-EF50VE

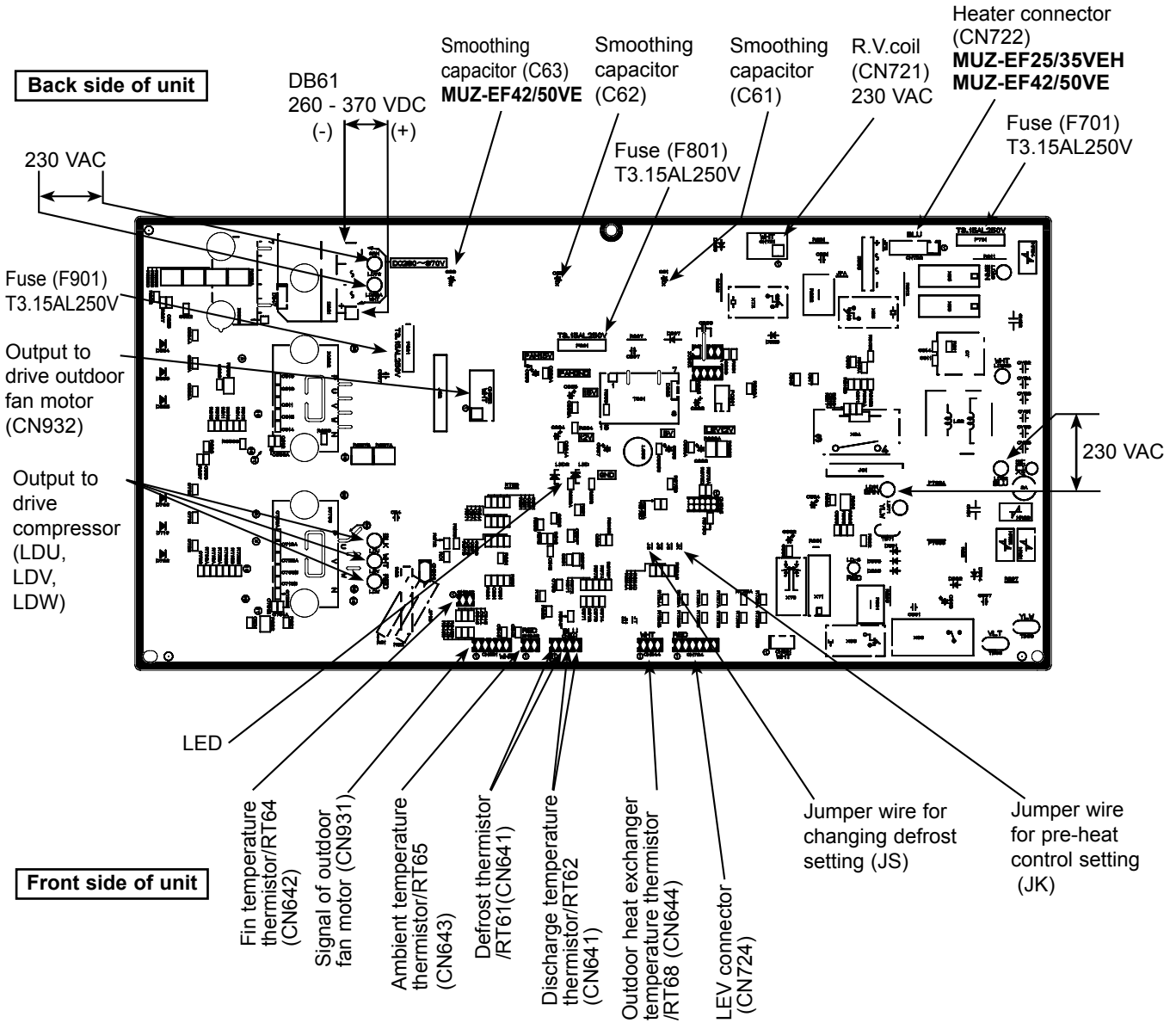

Defrost thermistor (RT61)
Ambient temperature thermistor (RT65)
Outdoor heat exchanger temperature thermistor (RT68)

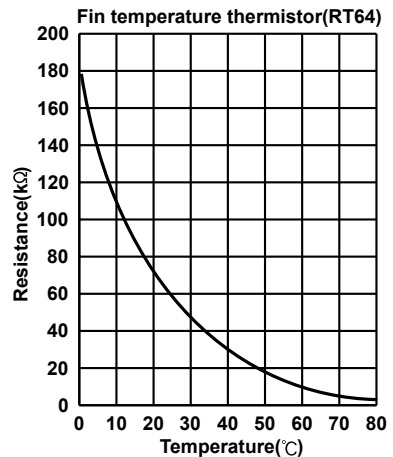
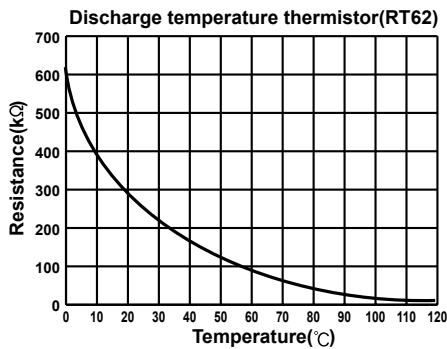
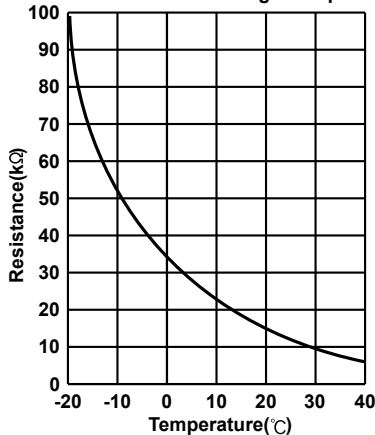

<"Terminal with locking mechanism" Detaching points>

The terminal which has the locking mechanism can be detached as shown below.
There are two types (refer to (1) and (2)) of the terminal with locking mechanism.
The terminal without locking mechanism can be detached by pulling it out.
Check the shape of the terminal before detaching.

(1) Slide the sleeve and check if there is a locking lever or not.

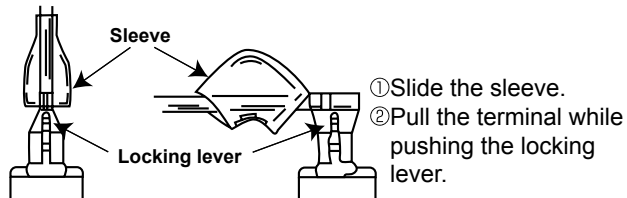

(2) The terminal with this connector has the locking mechanism.

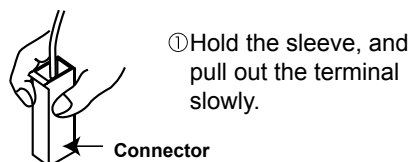

12-1. MUZ-EF25VE MUZ-EF25VEH MUZ-EF35VE MUZ-EF35VEH MUZ-EF42VE

NOTE: Turn OFF power supply before disassembly.

OPERATING PROCEDURE	PHOTOS
<p>1. Removing the cabinet</p> <ol style="list-style-type: none"> (1) Remove the screw fixing the service panel. (2) Pull down the service panel and remove it. (3) Disconnect the power supply and indoor/outdoor connecting wire. (4) Remove the screws fixing the top panel. (5) Remove the top panel. (6) Remove the screws fixing the cabinet. (7) Remove the cabinet. (8) Remove the screws fixing the back panel. (9) Remove the back panel. 	<p>Photo 1</p> <p>Photo 2</p>

OPERATING PROCEDURE

2. Removing the inverter assembly, inverter P.C. board

- (1) Remove the cabinet and panels. (Refer to 1.)
- (2) Disconnect the lead wire to the reactor and the following connectors:
<Inverter P.C. board>
CN721 (R.V. coil)
CN722 (Defrost heater)
CN931, CN932 (Fan motor)
CN641 (Defrost thermistor and discharge temperature thermistor)
CN643 (Ambient temperature thermistor)
CN644 (Outdoor heat exchanger temperature thermistor)
CN724 (LEV)
- (3) Remove the compressor connector (CN61).
- (4) Remove the screws fixing the heat sink support and the separator.
- (5) Remove the fixing screws of the terminal block support and the back panel.
- (6) Remove the inverter assembly.
- (7) Remove the screw of the earth wire and screw of the terminal block support.
- (8) Remove the heat sink support from the P.C. board support.
- (9) Remove the screw of the inverter P.C. board and remove the inverter P.C. board from the P.C. board support.

3. Removing R.V. coil

- (1) Remove the cabinet and panels. (Refer to 1.)
- (2) Disconnect the following connectors:
<Inverter P.C. board>
CN721 (R.V. coil)
- (3) Remove the R.V. coil.

4. Removing the discharge temperature thermistor, defrost thermistor, outdoor heat exchanger temperature thermistor and ambient temperature thermistor

- (1) Remove the cabinet and panels. (Refer to 1.)
- (2) Disconnect the lead wire to the reactor and the following connectors:
<Inverter P.C. board>
CN641 (Defrost thermistor and discharge temperature thermistor)
CN643 (Ambient temperature thermistor)
CN644 (Outdoor heat exchanger temperature thermistor)
- (3) Pull out the discharge temperature thermistor from its holder.
- (4) Pull out the defrost thermistor from its holder. (Photo 6)
- (5) Pull out the outdoor heat exchanger temperature thermistor from its holder. (Photo 6)
- (6) Pull out the ambient temperature thermistor from its holder.

PHOTOS

Photo 3

Screws of the heat sink support and the separator Screws of the terminal block support and the back panel

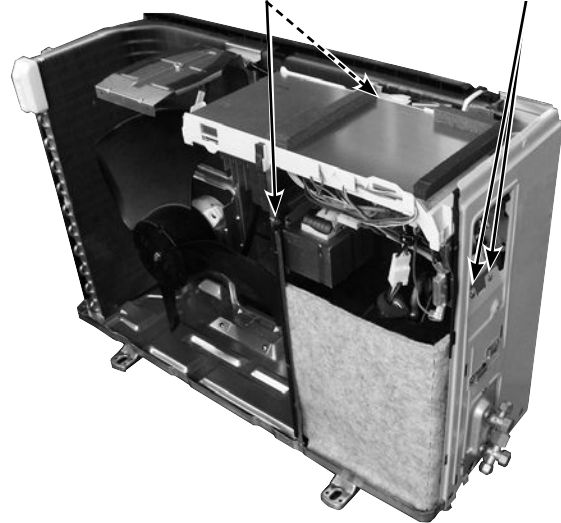

Photo 4 (Inverter assembly)

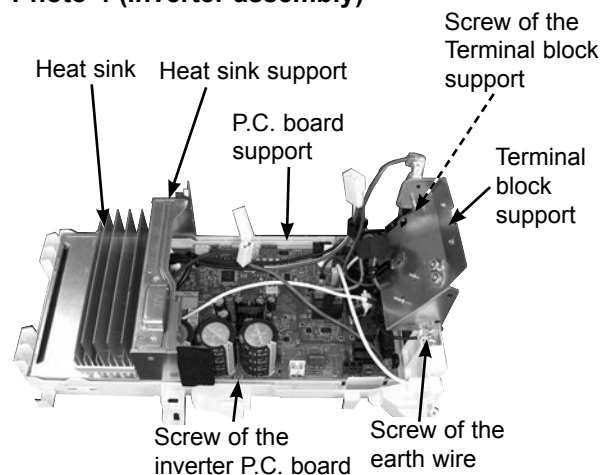

Photo 5

Screw of the R.V. coil



Discharge temperature thermistor

OPERATING PROCEDURE

5. Removing outdoor fan motor

- (1) Remove the cabinet and panels. (Refer to 1.)
- (2) Disconnect the following connectors:
<Inverter P.C. board>
CN931, CN932 (Fan motor)
- (3) Remove the propeller nut.
- (4) Remove the propeller.
- (5) Remove the screws fixing the fan motor.
- (6) Remove the fan motor.

6. Removing the compressor and 4-way valve

- (1) Remove the cabinet and panels. (Refer to 1.)
- (2) Remove the inverter assembly. (Refer to 2.)
- (3) Recover gas from the refrigerant circuit.
NOTE: Recover gas from the pipes until the pressure gauge shows 0 kg/cm² (0 MPa).
- (4) Detach the brazed part of the suction and the discharge pipe connected with compressor.
- (5) Remove the nuts of compressor legs.
- (6) Remove the compressor.
- (7) Detach the brazed part of pipes connected with 4-way valve.

PHOTOS

Photo 6

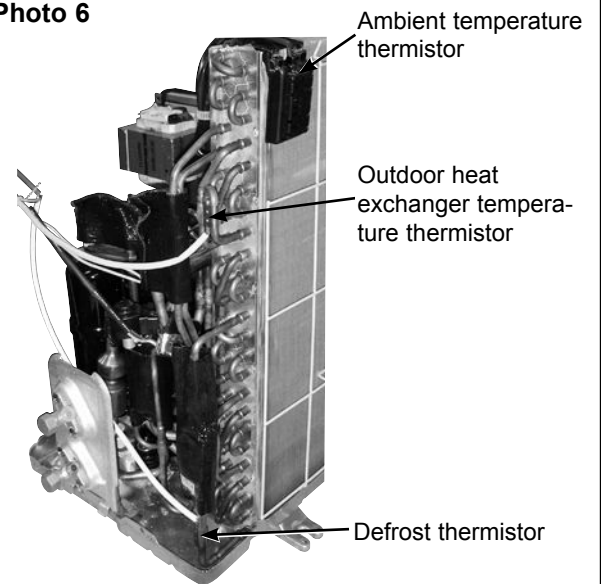

Photo 7

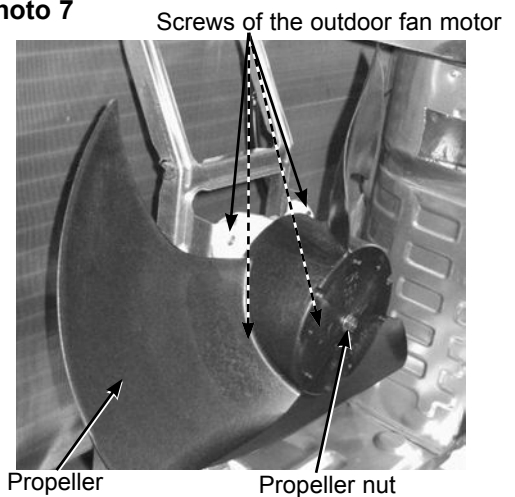
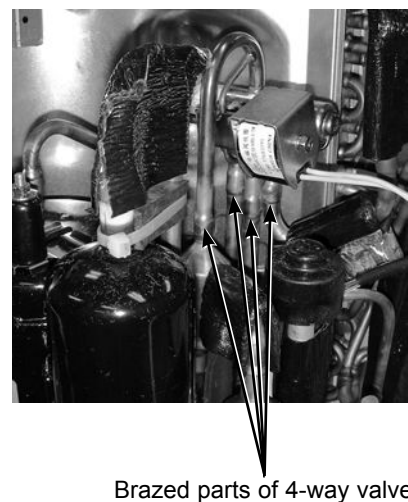
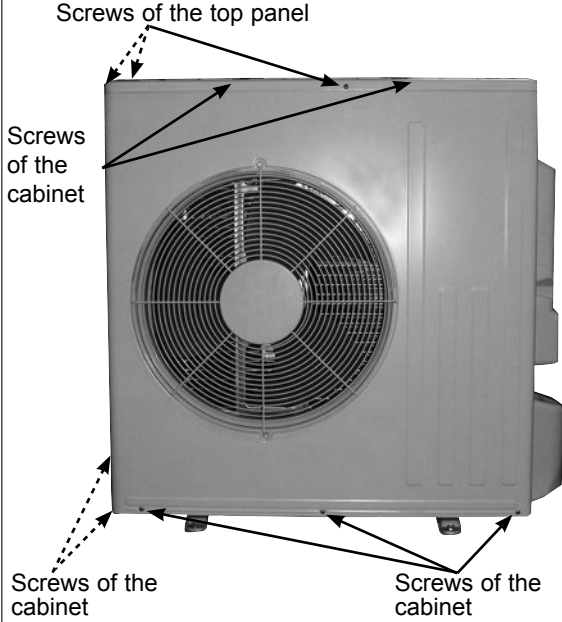
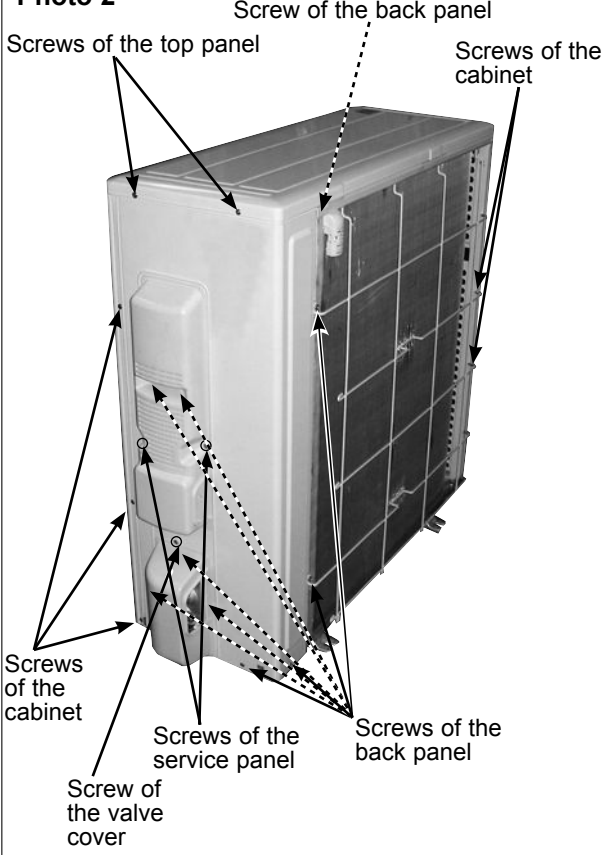

Photo 8



12-2. MUZ-EF50VE

NOTE: Turn OFF power supply before disassembly.

OPERATING PROCEDURE	PHOTOS
<p>1. Removing the cabinet</p> <ol style="list-style-type: none">(1) Remove the screws of the service panel.(2) Remove the screws of the top panel.(3) Remove the screw of the valve cover.(4) Remove the service panel.(5) Remove the top panel.(6) Remove the valve cover.(7) Disconnect the power supply and indoor/outdoor connecting wire.(8) Remove the screws of the cabinet.(9) Remove the cabinet.(10) Remove the screws of the back panel.(11) Remove the back panel.	<p>Photo 1</p>  <p>Screws of the top panel</p> <p>Screws of the cabinet</p> <p>Screws of the cabinet</p> <p>Screws of the cabinet</p> <p>Photo 2</p>  <p>Screw of the back panel</p> <p>Screws of the top panel</p> <p>Screws of the cabinet</p> <p>Screws of the cabinet</p> <p>Screws of the service panel</p> <p>Screws of the back panel</p> <p>Screw of the valve cover</p>

OPERATING PROCEDURE

2. Removing the inverter assembly, inverter P.C. board

- (1) Remove the cabinet and panels. (Refer to 1.)
- (2) Disconnect the lead wire to the reactor and the following connectors:
<Inverter P.C. board>
CN721 (R.V. coil)
CN931, CN932 (Fan motor)
CN641 (Defrost thermistor and discharge temperature thermistor)
CN643 (Ambient temperature thermistor)
CN644 (Outdoor heat exchanger temperature thermistor)
CN724 (LEV)
- (3) Remove the compressor connector.
- (4) Remove the screws fixing the heat sink support and the separator.
- (5) Remove the fixing screws of the terminal block support and the back panel.
- (6) Remove the inverter assembly.
- (7) Remove the screw of the earth wire, screw of the P.C. board cover and screws of the terminal block support.
- (8) Remove the heat sink support from the P.C. board support.
- (9) Remove the screw of the inverter P.C. board and the inverter P.C. board from the P.C. board support.

3. Removing R.V. coil

- (1) Remove the cabinet and panels. (Refer to 1.)
- (2) Disconnect the following connector:
<Inverter P.C. board>
CN721 (R.V. coil)
- (3) Remove the R.V. coil.

PHOTOS

Photo 3

Screw of the heat sink support and the separator

Screw of the terminal block support and the back panel

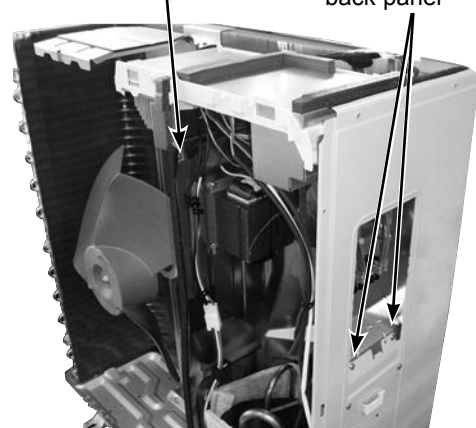

Photo 4

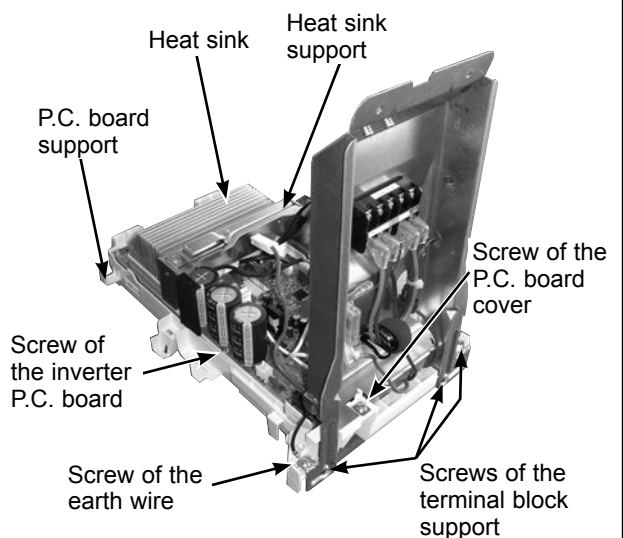
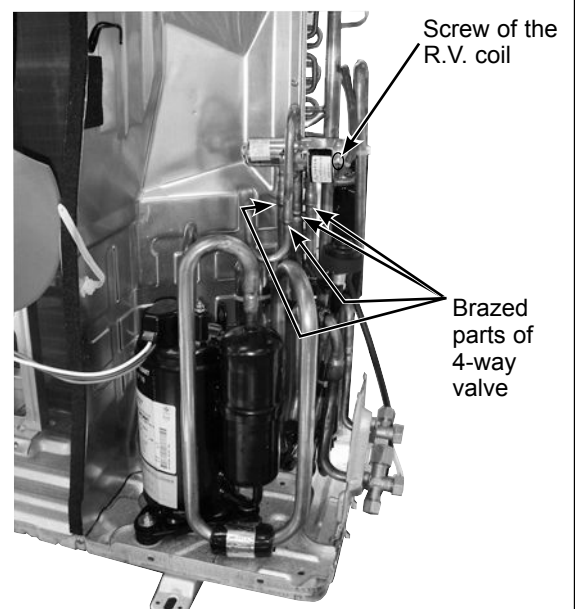

Photo 5



OPERATING PROCEDURE

4. Removing the discharge temperature thermistor, defrost thermistor, outdoor heat exchanger temperature thermistor and ambient temperature thermistor

- (1) Remove the cabinet and panels. (Refer to 1.)
- (2) Disconnect the lead wire to the reactor and the following connectors:
<Inverter P.C. board>
CN641 (Defrost thermistor and discharge temperature thermistor)
CN643 (Ambient temperature thermistor)
CN644 (Outdoor heat exchanger temperature thermistor)
- (3) Pull out the discharge temperature thermistor from its holder.
- (4) Pull out the defrost thermistor from its holder.
- (5) Pull out the outdoor heat exchanger temperature thermistor from its holder.
- (6) Pull out the ambient temperature thermistor from its holder.

5. Removing outdoor fan motor

- (1) Remove the top panel, cabinet and service panel. (Refer to 1.)
- (2) Disconnect the following connectors:
<Inverter P.C. board>
CN931 and CN932 (Fan motor)
- (3) Remove the propeller nut.
- (4) Remove the propeller.
- (5) Remove the screws fixing the fan motor.
- (6) Remove the fan motor.

6. Removing the compressor and 4-way valve

- (1) Remove the top panel, cabinet and service panel. (Refer to 1.)
- (2) Remove the back panel. (Refer to 1.)
- (3) Remove the inverter assembly. (Refer to 2.)
- (4) Recover gas from the refrigerant circuit.
NOTE: Recover gas from the pipes until the pressure gauge shows 0 kg/cm² (0 MPa).
- (5) Detach the brazed part of the suction and the discharge pipe connected with compressor.
- (6) Remove the compressor nuts.
- (7) Remove the compressor.
- (8) Detach the brazed part of 4-way valve and pipe. (Photo 5)

PHOTOS

Photo 6

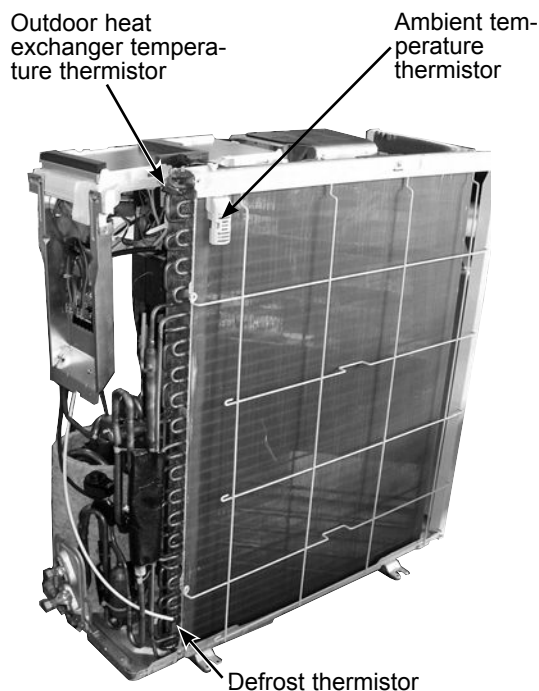

Photo 7

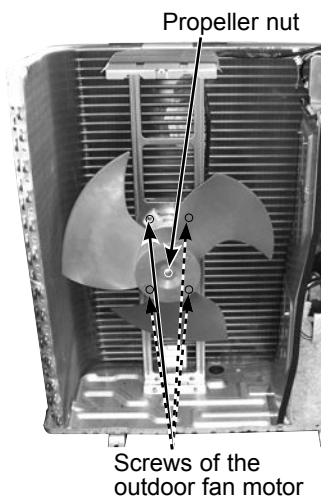
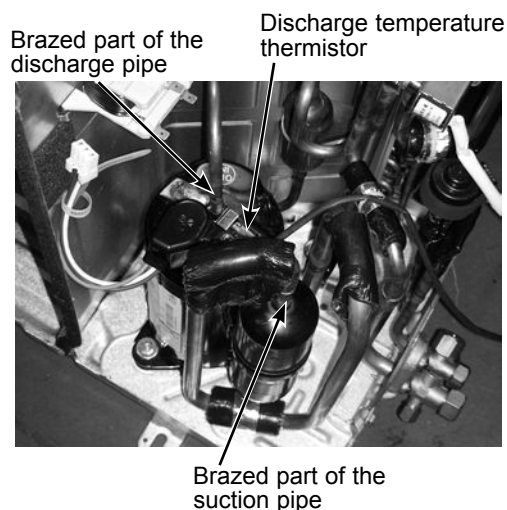

Photo 8





© Copyright 2010 MITSUBISHI ELECTRIC CO., LTD
Distributed in Mar. 2011. No. OBH590 REVISED EDITION-A
Distributed in Nov. 2010. No. OBH590
Made in Japan

New publication, effective Mar. 2011
Specifications subject to change without notice.