

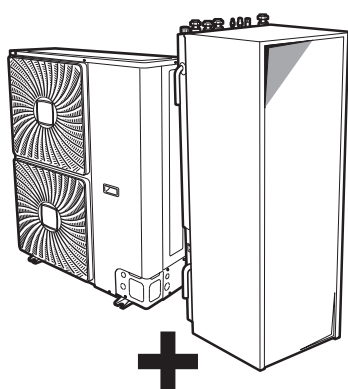

Installer reference guide

Daikin Altherma – Low temperature split



ERHQ011-014-016BA
ERLQ011-014-016CA
EHVZ16S18CB

Installer reference guide
Daikin Altherma – Low temperature split

English

Table of Contents

1	General safety precautions	3			
1.1	About the documentation	3			
1.1.1	Meaning of warnings and symbols	4			
1.2	For the installer	4			
1.2.1	General	4			
1.2.2	Installation site	4			
1.2.3	Refrigerant	4			
1.2.4	Brine	5			
1.2.5	Water	5			
1.2.6	Electrical	5			
2	About the documentation	6			
2.1	About this document	6			
2.2	Installer reference guide at a glance	6			
3	About the box	7			
3.1	Overview: About the box	7			
3.2	Outdoor unit	7			
3.2.1	To unpack the outdoor unit	7			
3.2.2	To handle the outdoor unit	7			
3.2.3	To remove the accessories from the outdoor unit	7			
3.3	Indoor unit	7			
3.3.1	To unpack the indoor unit	7			
3.3.2	To remove the accessories from the indoor unit	7			
4	About the units and options	8			
4.1	Overview: About the units and options	8			
4.2	Identification	8			
4.2.1	Identification label: Outdoor unit	8			
4.2.2	Identification label: Indoor unit	8			
4.3	Combining units and options	9			
4.3.1	Possible options for the outdoor unit	9			
4.3.2	Possible options for the indoor unit	9			
4.3.3	Possible combinations of indoor unit and outdoor unit	10			
5	Application guidelines	10			
5.1	Overview: Application guidelines	10			
5.2	Setting up the space heating system	10			
5.2.1	Multiple rooms – Two LWT zones	10			
5.3	Setting up the domestic hot water tank	11			
5.3.1	System layout – Integrated DHW tank	11			
5.3.2	Selecting the volume and desired temperature for the DHW tank	11			
5.3.3	Setup and configuration – DHW tank	12			
5.3.4	DHW pump for instant hot water	12			
5.3.5	DHW pump for disinfection	12			
5.4	Setting up the energy metering	13			
5.4.1	Produced heat	13			
5.4.2	Consumed energy	13			
5.4.3	Normal kWh rate power supply	13			
5.4.4	Preferential kWh rate power supply	14			
5.5	Setting up the power consumption control	14			
5.5.1	Permanent power limitation	14			
5.5.2	Power limitation activated by digital inputs	14			
5.5.3	Power limitation process	15			
5.6	Setting up an external temperature sensor	15			
6	Preparation	15			
6.1	Overview: Preparation	15			
6.2	Preparing installation site	15			
6.2.1	Installation site requirements of the outdoor unit	16			
6.2.2	Additional installation site requirements of the outdoor unit in cold climates	16			
6.2.3	Installation site requirements of the indoor unit	16			
6.3	Preparing refrigerant piping	17			
6.3.1	Refrigerant piping requirements	17			
			6.3.2	Refrigerant piping insulation	17
			6.4	Preparing water piping	17
			6.4.1	Water circuit requirements	17
			6.4.2	Formula to calculate the expansion vessel pre-pressure	18
			6.4.3	To check the water volume and flow rate	18
			6.4.4	Changing the pre-pressure of the expansion vessel	19
			6.4.5	To check the water volume: Examples	20
			6.5	Preparing electrical wiring	20
			6.5.1	About preparing electrical wiring	20
			6.5.2	About preferential kWh rate power supply	20
				Overview of electrical connections except external actuators	21
			6.5.3	Overview of electrical connections for external and internal actuators	21
			7	Installation	21
			7.1	Overview: Installation	21
			7.2	Opening the units	22
			7.2.1	About opening the units	22
			7.2.2	To open the outdoor unit	22
			7.2.3	To open the indoor unit	22
			7.2.4	To open the switch box cover of the indoor unit	22
			7.3	Mounting the outdoor unit	22
			7.3.1	About mounting the outdoor unit	22
			7.3.2	Precautions when mounting the outdoor unit	23
			7.3.3	To provide the installation structure	23
			7.3.4	To install the outdoor unit	23
			7.3.5	To provide drainage	23
			7.3.6	To prevent the outdoor unit from falling over	24
			7.4	Mounting the indoor unit	24
			7.4.1	About mounting the indoor unit	24
			7.4.2	Precautions when mounting the indoor unit	24
			7.4.3	To install the indoor unit	24
			7.5	Connecting the refrigerant piping	24
			7.5.1	About connecting the refrigerant piping	24
			7.5.2	Precautions when connecting the refrigerant piping	25
			7.5.3	Guidelines when connecting the refrigerant piping	25
			7.5.4	Pipe bending guidelines	25
			7.5.5	To flare the pipe end	25
			7.5.6	To braze the pipe end	26
			7.5.7	Using the stop valve and service port	26
			7.5.8	To connect the refrigerant piping to the outdoor unit	27
			7.5.9	To connect the refrigerant piping to the indoor unit	28
			7.5.10	To determine if oil traps are required	28
			7.6	Checking the refrigerant piping	28
			7.6.1	About checking the refrigerant piping	28
			7.6.2	Precautions when checking the refrigerant piping	28
			7.6.3	Checking refrigerant piping: Setup	28
			7.6.4	To check for leaks	28
			7.6.5	To perform vacuum drying	29
			7.7	Charging refrigerant	29
			7.7.1	About charging refrigerant	29
			7.7.2	Precautions when charging refrigerant	29
			7.7.3	To determine the additional refrigerant amount	29
			7.7.4	To determine the complete recharge amount	30
			7.7.5	To charge refrigerant	30
			7.7.6	To fix the fluorinated greenhouse gases label	30
			7.8	Connecting the water piping	30
			7.8.1	About connecting the water piping	30
			7.8.2	Precautions when connecting the water piping	30
			7.8.3	To connect the water piping	30
			7.8.4	To connect the recirculation piping	31
			7.8.5	To connect the pressure relief valve to the drain	31
			7.8.6	To fill the water circuit	31
			7.8.7	To fill the domestic hot water tank	32
			7.8.8	To insulate the water piping	32
			7.9	Connecting the electrical wiring	32
			7.9.1	About connecting the electrical wiring	32
			7.9.2	About electrical compliance	32

7.9.3	Precautions when connecting the electrical wiring	33	12.1	Overview: Troubleshooting.....	65
7.9.4	Guidelines when connecting the electrical wiring	33	12.2	Precautions when troubleshooting	66
7.9.5	Specifications of standard wiring components.....	33	12.3	Solving problems based on symptoms.....	66
7.9.6	To connect the electrical wiring on the outdoor unit....	33	12.3.1	Symptom: The unit is NOT heating as expected	66
7.9.7	To reposition the air thermistor on the outdoor unit	34	12.3.2	Symptom: The compressor does NOT start (space heating or domestic water heating).....	66
7.9.8	To connect the electrical wiring on the indoor unit.....	35	12.3.3	Symptom: The pump is making noise (cavitation)	66
7.9.9	To connect the main power supply	36	12.3.4	Symptom: The pressure relief valve opens.....	66
7.9.10	To connect the backup heater power supply	36	12.3.5	Symptom: The water pressure relief valve leaks	67
7.9.11	To connect the user interface	37	12.3.6	Symptom: The space is NOT sufficiently heated at low outdoor temperatures	67
7.9.12	To connect the shut-off valve.....	37	12.3.7	Symptom: The pressure at the tapping point is temporarily unusual high	67
7.9.13	To connect the electrical meters	38	12.3.8	Symptom: Decoration panels are pushed away due to a swollen tank	67
7.9.14	To connect the domestic hot water pump	38	12.3.9	Symptom: Tank disinfection function is NOT completed correctly (AH-error).....	67
7.9.15	To connect the alarm output	38	12.4	Solving problems based on error codes	68
7.9.16	To connect the power consumption digital inputs	38	12.4.1	Error codes: Overview	68
7.9.17	To connect the safety thermostat (normal closed contact)	38			
7.10	Finishing the outdoor unit installation	39	13 Disposal		70
7.10.1	To finish the outdoor unit installation	39	13.1	Overview: Disposal.....	70
7.10.2	To close the outdoor unit	39	13.2	About pump down	70
7.11	Finishing the indoor unit installation	39	13.3	To pump down.....	70
7.11.1	To fix the user interface cover to the indoor unit.....	39	14 Technical data		71
7.11.2	To close the indoor unit.....	39	14.1	Overview: Technical data	71
8 Configuration		39	14.2	Dimensions and service space.....	71
8.1	Overview: Configuration	39	14.2.1	Dimensions: Outdoor unit	71
8.1.1	To connect the PC cable to the switch box.....	40	14.2.2	Service space: Outdoor unit.....	75
8.1.2	To access the most used commands	40	14.2.3	Dimensions and service space: Indoor unit	77
8.1.3	To copy the system settings from the first to the second user interface.....	41	14.3	Center of gravity	78
8.1.4	To copy the language set from the first to the second user interface	41	14.3.1	Center of gravity: Outdoor unit.....	78
8.1.5	Quick wizard: Set the system layout after first power ON.....	41	14.4	Components	79
8.2	Basic configuration	42	14.4.1	Components: Outdoor unit.....	79
8.2.1	Quick wizard: Language / time and date.....	42	14.4.2	Components: Indoor unit.....	81
8.2.2	Quick wizard: Standard.....	42	14.4.3	Components: Switch box (indoor unit).....	81
8.2.3	Quick wizard: Options	43	14.5	Piping diagram	82
8.2.4	Quick wizard: Capacities (energy metering)	45	14.5.1	Piping diagram: Outdoor unit	82
8.2.5	Space heating control	46	14.5.2	Piping diagram: Indoor unit	83
8.2.6	Domestic hot water control	48	14.6	Wiring diagram	84
8.2.7	Contact/helpdesk number	48	14.6.1	Wiring diagram: Outdoor unit	84
8.3	Advanced configuration/optimization.....	48	14.6.2	Wiring diagram: Indoor unit.....	92
8.3.1	Space heating operation: advanced	48	14.7	Technical specifications	97
8.3.2	Domestic hot water control: advanced.....	51	14.7.1	Technical specifications: Outdoor unit	97
8.3.3	Heat source settings	54	14.7.2	Technical specifications: Indoor unit.....	111
8.3.4	System settings.....	55	14.8	Operation range	114
8.4	Menu structure: Overview user settings	58	14.8.1	Operation range: Heating and cooling	114
8.5	Menu structure: Overview installer settings.....	59	14.8.2	Operation range: Domestic hot water	115
9 Commissioning		60	14.9	ESP curve	116
9.1	Overview: Commissioning	60	14.9.1	ESP curve: Indoor unit.....	116
9.2	Precautions when commissioning	60	15 Glossary		117
9.3	Checklist before commissioning	60	16 Field settings table		118
9.4	Checklist during commissioning	60			
9.4.1	To check the minimum flow rate	61	1	General safety precautions	
9.4.2	Air purge function.....	61	1.1	About the documentation	
9.4.3	To perform a test run	62			
9.4.4	To perform an actuator test run	62			
9.4.5	Underfloor heating screed dryout.....	62			
10 Hand-over to the user		64			
11 Maintenance and service		64			
11.1	Overview: Maintenance and service	64			
11.2	Maintenance safety precautions.....	64			
11.2.1	Opening the indoor unit.....	64			
11.3	Checklist for yearly maintenance of the outdoor unit	64			
11.4	Checklist for yearly maintenance of the indoor unit.....	64			
11.4.1	To drain the domestic hot water tank.....	65			
12 Troubleshooting		65			

1 General safety precautions

1.1 About the documentation

- The original documentation is written in English. All other languages are translations.
- The precautions described in this document cover very important topics, follow them carefully.
- The installation of the system, and all activities described in the installation manual and the installer reference guide must be performed by an authorized installer.

1 General safety precautions

1.1.1 Meaning of warnings and symbols



DANGER

Indicates a situation that results in death or serious injury.



DANGER: RISK OF ELECTROCUTION

Indicates a situation that could result in electrocution.



DANGER: RISK OF BURNING

Indicates a situation that could result in burning because of extreme hot or cold temperatures.



WARNING

Indicates a situation that could result in death or serious injury.



CAUTION

Indicates a situation that could result in minor or moderate injury.



NOTICE

Indicates a situation that could result in equipment or property damage.



INFORMATION

Indicates useful tips or additional information.



WARNING

Provide adequate measures to prevent that the unit can be used as a shelter by small animals. Small animals that make contact with electrical parts can cause malfunctions, smoke or fire.



CAUTION

Do NOT touch the air inlet or aluminum fins of the unit.



NOTICE

- Do NOT place any objects or equipment on top of the unit.
- Do NOT sit, climb or stand on the unit.



NOTICE

Works executed on the outdoor unit are best done under dry weather conditions to avoid water ingress.

In accordance with the applicable legislation, it might be necessary to provide a logbook with the product containing at least: information on maintenance, repair work, results of tests, stand-by periods,...

Also, at least, following information must be provided at an accessible place at the product:

- Instructions for shutting down the system in case of an emergency
- Name and address of fire department, police and hospital
- Name, address and day and night telephone numbers for obtaining service

In Europe, EN378 provides the necessary guidance for this logbook.

1.2 For the installer

1.2.1 General

If you are not sure how to install or operate the unit, contact your dealer.



NOTICE

Improper installation or attachment of equipment or accessories could result in electric shock, short-circuit, leaks, fire or other damage to the equipment. Only use accessories, optional equipment and spare parts made or approved by Daikin.



WARNING

Make sure installation, testing and applied materials comply with applicable legislation (on top of the instructions described in the Daikin documentation).



CAUTION

Wear adequate personal protective equipment (protective gloves, safety glasses,...) when installing, maintaining or servicing the system.



WARNING

Tear apart and throw away plastic packaging bags so that nobody, especially children, can play with them. Possible risk: suffocation.



DANGER: RISK OF BURNING

- Do NOT touch the refrigerant piping, water piping or internal parts during and immediately after operation. It could be too hot or too cold. Give it time to return to normal temperature. If you must touch it, wear protective gloves.
- Do NOT touch any accidental leaking refrigerant.

1.2.2 Installation site

- Provide sufficient space around the unit for servicing and air circulation.
- Make sure the installation site withstands the unit's weight and vibration.
- Make sure the area is well ventilated.
- Make sure the unit is level.

Do NOT install the unit in the following places:

- In potentially explosive atmospheres.
- In places where there is machinery that emits electromagnetic waves. Electromagnetic waves may disturb the control system, and cause malfunction of the equipment.
- In places where there is a risk of fire due to the leakage of flammable gases (example: thinner or gasoline), carbon fibre, ignitable dust.
- In places where corrosive gas (example: sulphurous acid gas) is produced. Corrosion of copper pipes or soldered parts may cause the refrigerant to leak.

1.2.3 Refrigerant

If applicable. See the installation manual or installer reference guide of your application for more information.



NOTICE

Make sure refrigerant piping installation complies with applicable legislation. In Europe, EN378 is the applicable standard.



NOTICE

Make sure the field piping and connections are not subjected to stress.



WARNING

During tests, NEVER pressurize the product with a pressure higher than the maximum allowable pressure (as indicated on the nameplate of the unit).



WARNING

Take sufficient precautions in case of refrigerant leakage. If refrigerant gas leaks, ventilate the area immediately. Possible risks:

- Excessive refrigerant concentrations in a closed room can lead to oxygen deficiency.
- Toxic gas may be produced if refrigerant gas comes into contact with fire.



WARNING

Always recover the refrigerant. Do NOT release them directly into the environment. Use a vacuum pump to evacuate the installation.



NOTICE

After all the piping has been connected, make sure there is no gas leak. Use nitrogen to perform a gas leak detection.



NOTICE



- To avoid compressor breakdown, do NOT charge more than the specified amount of refrigerant.
- When the refrigerant system is to be opened, refrigerant must be treated according to the applicable legislation.



WARNING

Make sure there is no oxygen in the system. Refrigerant may only be charged after performing the leak test and the vacuum drying.

- In case re-charge is required, refer to the nameplate of the unit. It states the type of refrigerant and necessary amount.
- The unit is factory charged with refrigerant and depending on pipe sizes and pipe lengths some systems require additional charging of refrigerant.
- Only use tools exclusively for the refrigerant type used in the system, this to ensure pressure resistance and prevent foreign materials from entering into the system.
- Charge the liquid refrigerant as follows:

If	Then
A siphon tube is present (i.e., the cylinder is marked with "Liquid filling siphon attached")	Charge with the cylinder upright. 
A siphon tube is NOT present	Charge with the cylinder upside down. 

- Open refrigerant cylinders slowly.
- Charge the refrigerant in liquid form. Adding it in gas form may prevent normal operation.



CAUTION

When the refrigerant charging procedure is done or when pausing, close the valve of the refrigerant tank immediately. If the valve is not closed immediately, remaining pressure might charge additional refrigerant.
Possible consequence: Incorrect refrigerant amount.

1.2.4 Brine

If applicable. See the installation manual or installer reference guide of your application for more information.



WARNING

The selection of the brine MUST be in accordance with the applicable legislation.



WARNING

Take sufficient precautions in case of brine leakage. If brine leaks, ventilate the area immediately and contact your local dealer.



WARNING

The ambient temperature inside the unit can get much higher than that of the room, e.g. 70°C. In case of a brine leak, hot parts inside the unit can create a hazardous situation.



WARNING

The use and installation of the application MUST comply with the safety and environmental precautions specified in the applicable legislation.

1.2.5 Water

If applicable. See the installation manual or installer reference guide of your application for more information.



NOTICE

Make sure water quality complies with EU directive 98/83 EC.

1.2.6 Electrical



DANGER: RISK OF ELECTROCUTION

- Turn OFF all power supply before removing the switch box cover, connecting electrical wiring or touching electrical parts.
- Disconnect the power supply for more than 1 minute, and measure the voltage at the terminals of main circuit capacitors or electrical components before servicing. The voltage MUST be less than 50 V DC before you can touch electrical components. For the location of the terminals, see the wiring diagram.
- Do NOT touch electrical components with wet hands.
- Do NOT leave the unit unattended when the service cover is removed.



WARNING

If NOT factory installed, a main switch or other means for disconnection, having a contact separation in all poles providing full disconnection under overvoltage category III condition, shall be installed in the fixed wiring.

2 About the documentation



WARNING

- ONLY use copper wires.
- Make sure the field wiring complies with the applicable legislation.
- All field wiring must be performed in accordance with the wiring diagram supplied with the product.
- NEVER squeeze bundled cables and make sure they do not come in contact with the piping and sharp edges. Make sure no external pressure is applied to the terminal connections.
- Make sure to install earth wiring. Do NOT earth the unit to a utility pipe, surge absorber, or telephone earth. Incomplete earth may cause electrical shock.
- Make sure to use a dedicated power circuit. NEVER use a power supply shared by another appliance.
- Make sure to install the required fuses or circuit breakers.
- Make sure to install an earth leakage protector. Failure to do so may cause electric shock or fire.
- When installing the earth leakage protector, make sure it is compatible with the inverter (resistant to high frequency electric noise) to avoid unnecessary opening of the earth leakage protector.

Install power cables at least 1 metre away from televisions or radios to prevent interference. Depending on the radio waves, a distance of 1 metre may not be sufficient.



WARNING

- After finishing the electrical work, confirm that each electrical component and terminal inside the electrical components box is connected securely.
- Make sure all covers are closed before starting up the unit.



NOTICE

Only applicable if the power supply is three-phase, and the compressor has an ON/OFF starting method.

If there exists the possibility of reversed phase after a momentary black out and the power goes on and off while the product is operating, attach a reversed phase protection circuit locally. Running the product in reversed phase can break the compressor and other parts.

2 About the documentation

2.1 About this document

Target audience

Authorised installers

Documentation set

This document is part of a documentation set. The complete set consists of:

- **General safety precautions:**
 - Safety instructions that you must read before installing
 - Format: Paper (in the box of the indoor unit)
- **Indoor unit installation manual:**
 - Installation instructions
 - Format: Paper (in the box of the indoor unit)

- **Outdoor unit installation manual:**
 - Installation instructions
 - Format: Paper (in the box of the outdoor unit)
- **Installer reference guide:**
 - Preparation of the installation, technical specifications, good practices, reference data,...
 - Format: Digital files on <http://www.daikineurope.com/support-and-manuals/product-information/>
- **Addendum book for optional equipment:**
 - Additional info about how to install optional equipment
 - Format: Paper (in the box of the indoor unit) + Digital files on <http://www.daikineurope.com/support-and-manuals/product-information/>

Latest revisions of the supplied documentation may be available on the regional Daikin website or via your dealer.

The original documentation is written in English. All other languages are translations.

2.2 Installer reference guide at a glance

Chapter	Description
General safety precautions	Safety instructions that you must read before installing
About the documentation	What documentation exists for the installer
About the box	How to unpack the units and remove their accessories
About the units and options	<ul style="list-style-type: none"> ▪ How to identify the units ▪ Possible combinations of units and options
Application guidelines	Various installation setups of the system
Preparation	What to do and know before going on-site
Installation	What to do and know to install the system
Configuration	What to do and know to configure the system after it is installed
Commissioning	What to do and know to commission the system after it is configured
Hand-over to the user	What to give and explain to the user
Maintenance and service	How to maintain and service the units
Troubleshooting	What to do in case of problems
Disposal	How to dispose of the system
Technical data	Specifications of the system
Glossary	Definition of terms
Field settings table	Table to be filled in by the installer, and kept for future reference Note: There is also an installer settings table in the user reference guide. This table has to be filled in by the installer and handed over to the user.

3 About the box

3.1 Overview: About the box

This chapter describes what you have to do after the boxes with the outdoor and indoor unit are delivered on-site.

It contains information about:

- Unpacking and handling the units
- Removing the accessories from the units

Keep the following in mind:

- At delivery, the unit must be checked for damage. Any damage must be reported immediately to the carrier's claims agent.
- Bring the packed unit as close as possible to its final installation position to prevent damage during transport.

3.2 Outdoor unit

3.2.1 To unpack the outdoor unit

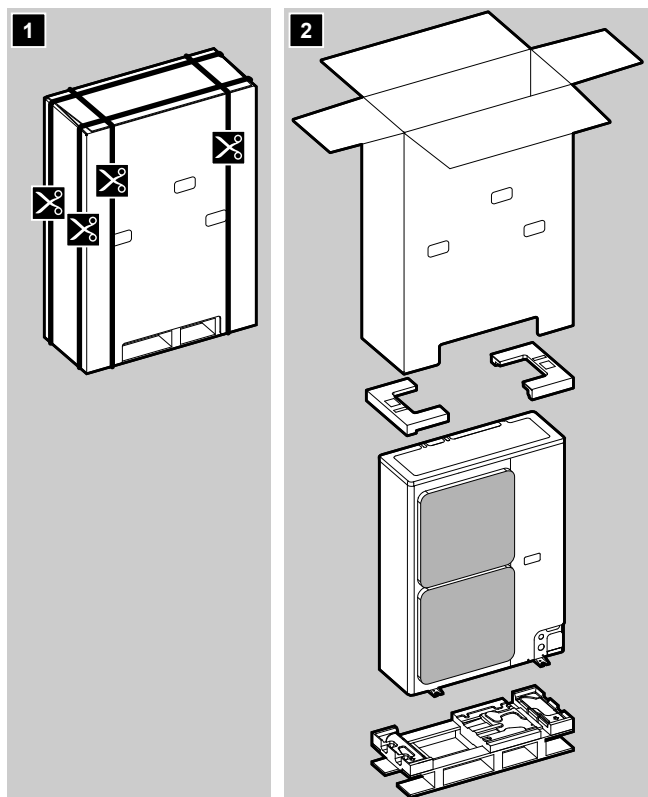

3.2.2 To handle the outdoor unit

Carry the unit slowly as shown:



CAUTION

To avoid injury, do NOT touch the air inlet or aluminum fins of the unit.

3.2.3 To remove the accessories from the outdoor unit

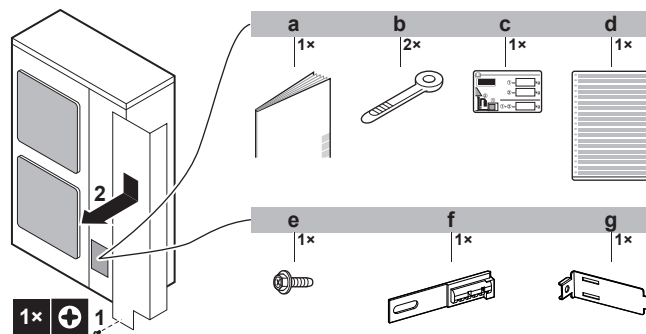

- a Outdoor unit installation manual
- b Cable tie
- c Fluorinated greenhouse gases label
- d Multilingual fluorinated greenhouse gases label
- e Screw (only for ERLQ)
- f Thermistor fixing plate (spare) (only for ERLQ)
- g Thermistor fixture (only for ERLQ)

3.3 Indoor unit

3.3.1 To unpack the indoor unit

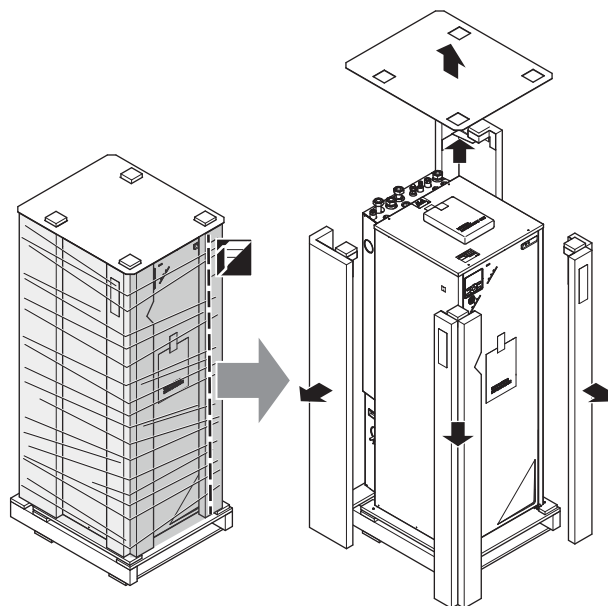

3.3.2 To remove the accessories from the indoor unit

- 1 Remove the screws at the top of the unit.
- 2 Remove the top panel.
- 3 Remove the screws at the front of the unit.
- 4 Push on the button on the bottom of the front plate.
- 5 Remove the front plate.



WARNING: Sharp edges

Take the front plate on the upper part instead of the lower part. Watch your fingers, there are sharp edges on the lower part of the front plate.

4 About the units and options

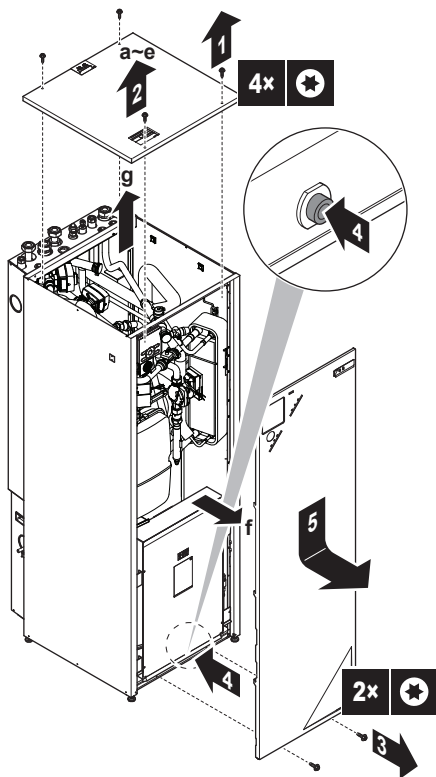

6 Remove the accessories.

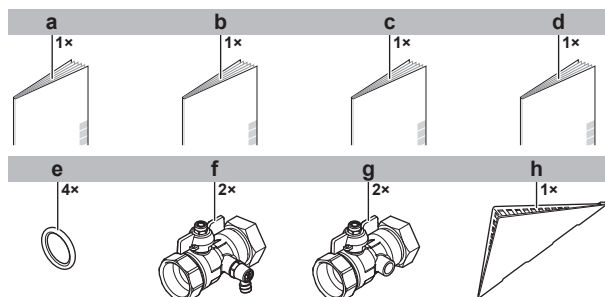

- a General safety precautions
- b Addendum book for optional equipment
- c Indoor unit installation manual
- d Operation manual
- e Sealing ring for shut-off valve
- f Shut-off valve with drain/fill point
- g Shut-off valve
- h User interface cover

7 Reinstall the top panel and the front plate.

4 About the units and options

4.1 Overview: About the units and options

This chapter contains information about:

- Identifying the outdoor unit
- Identifying the indoor unit
- Combining outdoor and indoor units
- Combining the outdoor unit with options
- Combining the indoor unit with options

4.2 Identification



NOTICE

When installing or servicing several units at the same time, make sure NOT to switch the service panels between different models.

4.2.1 Identification label: Outdoor unit

Location

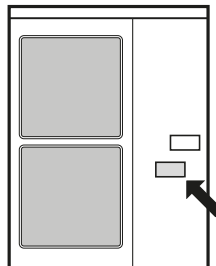

Model identification

- ERLQ: Contains components (insulation, bottom plate heater, ...) to prevent freeze-up in areas with low ambient temperature and high humidity.
- ERHQ: Does NOT contain these components.

Example: ER L Q 011 CA W1

Code	Explanation
ER	European split outdoor pair heat pump
L	H=Low water temperature – ambient zone: 0~-10°C L=Low water temperature – ambient zone: -10~-20°C
Q	Refrigerant R410A
011	Capacity class
CA	Model series
W1	Power supply

4.2.2 Identification label: Indoor unit

Location

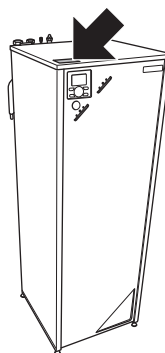

Model identification

Example: E HV Z 04 S 18 CB 3V

Code	Description
E	European model
HV	Floor-standing indoor unit with integrated tank
Z	Dual-zone model
04	Capacity class

Code	Description
S	Integrated tank material: Stainless steel
18	Integrated tank volume
CB	Model series
3V	Backup heater model

4.3 Combining units and options

4.3.1 Possible options for the outdoor unit

Demand PCB (KRP58M51) (only for ERLQ)

- Limits the maximum current. However, this also decreases the heating/cooling capacity of the system.
- Only the "Setting of demand running" function of the demand PCB is applicable.
- For installation instructions, see the installation manual of the demand PCB.

Snow cover (EK016SNC) (only for ERLQ)

- Prevents the outdoor unit from being snowed up.
- Recommended in areas with low ambient temperatures or heavy snowfall.
- For installation instructions, see the installation manual of the snow cover.

Drain plug kit (EKDK04) (only for ERHQ)

- Gathers the condensate from the outdoor unit and guides it away through 1 plug in the bottom plate.
- For ERLQ: Drain plug kit is not applicable.
- For ERHQ: Drain plug kit is option.
- Cannot be combined with bottom plate heater.
- For installation instructions, see the installation manual of the drain plug kit.

Bottom plate heater (EKBPPTH16A) (only for ERHQ in combination with C* indoor unit)

- Prevents freeze-up of the bottom plate.
- Recommended in areas with low ambient temperature and high humidity.
- For ERLQ: Bottom plate heater is standard (factory-mounted).
- For ERHQ: Bottom plate heater is option.
- Cannot be combined with drain plug kit.
- If you install EKBPPTH16A, you also have to install the digital I/O PCB (EKRP1HB).
- For installation instructions, see the installation manual of the bottom plate heater and addendum book for optional equipment.

4.3.2 Possible options for the indoor unit

User interface (EKUCBL*)

The user interface and a possible additional user interface are available as an option.

The additional user interface can be connected:

- To have both:
 - control close to the indoor unit,
 - room thermostat functionality in the principal space to be heated.
- To have an interface containing other languages.

Following user interfaces are available:

- EKUCBL1 contains following languages: German, French, Dutch, Italian.
- EKUCBL2 contains following languages: English, Swedish, Norwegian, Finnish.
- EKUCBL3 contains following languages: English, Spanish, Greek, Portuguese.
- EKUCBL4 contains following languages: English, Turkish, Polish, Romanian.
- EKUCBL5 contains following languages: German, Czech, Slovenian, Slovakian.
- EKUCBL6 contains following languages: English, Croatian, Hungarian, Estonian.
- EKUCBL7 contains following languages: English, German, Russian, Danish.

Languages on the user interface can be uploaded by PC software or copied from an user interface to the other.

For installation instructions, see ["7.9.11 To connect the user interface" on page 37](#).

Simplified user interface (EKUCBS)

- The simplified user interface can only be used in combination with the main user interface.
- The simplified user interface acts as room thermostat and needs to be installed in the room that you want it to control.

For installation instructions, see the installation and operation manual of the simplified user interface.

Room thermostat (EKRTWA, EKTR1)

You can connect an optional room thermostat to the indoor unit. This thermostat can either be wired (EKRTWA) or wireless (EKTR1).

For installation instructions, see the installation manual of the room thermostat and addendum book for optional equipment.

Remote sensor for wireless thermostat (EKRTETS)

You can use a wireless indoor temperature sensor (EKRTETS) only in combination with the wireless thermostat (EKTR1).

For installation instructions, see the installation manual of the room thermostat and addendum book for optional equipment.

Digital I/O PCB (EKRP1HB)

The digital I/O PCB is required to provide following signals:

- Alarm output
- Space heating On/OFF output
- Changeover to external heat source
- Only for EHVS16S18 model: Control signal for bottom plate heater kit EKBPPTH16A.

For installation instructions, see the installation manual of the digital I/O PCB and addendum book for optional equipment.

Demand PCB (EKRP1AHTA)

To enable the power saving consumption control by digital inputs you must install the demand PCB.

For installation instructions, see the installation manual of the demand PCB and addendum book for optional equipment.

Remote indoor sensor (KRCS01-1)

By default the internal user interface sensor will be used as room temperature sensor.

As an option the remote indoor sensor can be installed to measure the room temperature on another location.

For installation instructions, see the installation manual of the remote indoor sensor and addendum book for optional equipment.

5 Application guidelines



INFORMATION

- The remote indoor sensor can only be used in case the user interface is configured with room thermostat functionality.
- You can only connect either the remote indoor sensor or the remote outdoor sensor.

Remote outdoor sensor (EKRSKA1)

By default the sensor inside the outdoor unit will be used to measure the outdoor temperature.

As an option the remote outdoor sensor can be installed to measure the outdoor temperature on another location (e.g. to avoid direct sunlight) to have an improved system behaviour.

For installation instructions, see the installation manual of the remote outdoor sensor.



INFORMATION

You can only connect either the remote indoor sensor or the remote outdoor sensor.

PC configurator (EKPCAB)

The PC cable makes a connection between the switch box of the indoor unit and a PC. It gives the possibility to upload different language files to the user interface and indoor parameters to the indoor unit. For the available language files, contact your local dealer.

The software and corresponding operating instructions are available on <http://www.daikineurope.com/support-and-manuals/software-downloads/>.

For installation instructions, see the installation manual of the PC cable and "8 Configuration" on page 39.

Heat pump convector (FWXV)

For providing space heating/cooling, it is possible to use heat pump convectors (FWXV).

For installation instructions, refer to the installation manual of the heat pump convectors, and the addendum book for optional equipment.

4.3.3 Possible combinations of indoor unit and outdoor unit

Outdoor unit	Indoor unit
	EHVZ16
ERHQ011+ERLQ011	○
ERHQ014+ERLQ014	○
ERHQ016+ERLQ016	○

5 Application guidelines

5.1 Overview: Application guidelines

The purpose of the application guidelines is to give a glance of the possibilities of the Daikin heat pump system.



NOTICE

- The illustrations in the application guidelines are meant for reference only, and are NOT to be used as detailed hydraulic diagrams. The detailed hydraulic dimensioning and balancing are NOT shown, and are the responsibility of the installer.
- For more information about the configuration settings to optimize heat pump operation, see "8 Configuration" on page 39.

This chapter contains application guidelines for:

- Setting up the space heating system
- Setting up the domestic hot water tank
- Setting up the energy metering
- Setting up the power consumption
- Setting up an external temperature sensor

5.2 Setting up the space heating system

The Daikin heat pump system supplies leaving water to heat emitters in one or more rooms.

Because the system offers a wide flexibility to control the temperature in each room, you need to answer the following questions first:

- How many rooms are heated by the Daikin heat pump system?
- Which heat emitter types are used in each room and what is their design leaving water temperature?

Once the space heating requirements are clear, Daikin recommends to follow the setup guidelines below.



NOTICE

If an external room thermostat is used, the external room thermostat will control the room frost protection. However, the room frost protection is only possible if the leaving water temperature control on the unit's user interface is turned ON.



INFORMATION

In case an external room thermostat is used and room frost protection needs to be guaranteed in all conditions, then you have to set auto emergency [A.5.1.2] to 1.

5.2.1 Multiple rooms – Two LWT zones

This unit is designed to deliver water at 2 different temperatures. A typical installation consists of underfloor heating at a lower temperature and radiators at a higher water temperature.

In this document:

- Main zone = Zone with the lowest design temperature
- Additional zone = Zone with the highest design temperature

Typical example:

Room (zone)	Heat emitters: Design temperature
Living room (main zone)	Under floor heating: 35°C
Bed rooms (additional zone)	Heat pump convectors: 45°C

Setup

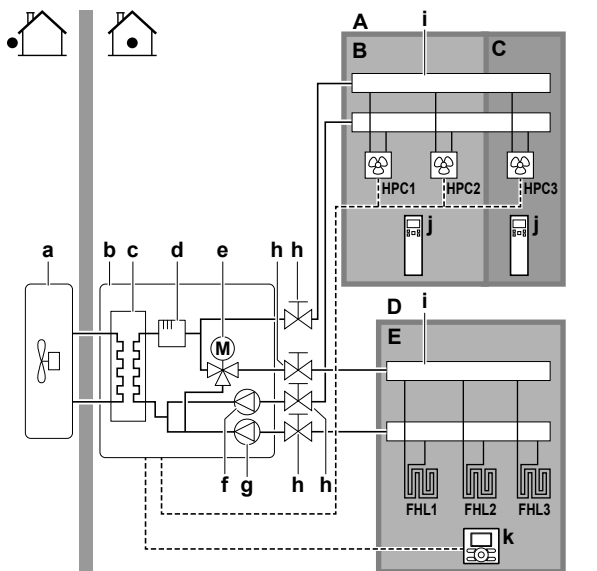

- A Additional leaving water temperature zone
- B Room 1
- C Room 2
- D Main leaving water temperature zone
- E Room 3
- a Outdoor unit
- b Indoor unit
- c Heat exchanger
- d Backup heater
- e Motorised 3-way valve (mixing the main zone)
- f Additional pump
- g Main pump
- h Shut-off valve
- i Collector (field supply)
- j Remote controller of the heat pump convectors (field supply)
- k User interface (field supply)
- HPC1...3 Heat pump convectors (field supply)
- FHL1...3 Floor heating loops (field supply)

- For the main zone: the room temperature is controlled by the user interface, which is used as room thermostat.
- For the additional zone:
 - The external thermostat is directly connected to the indoor unit.
 - The desired room temperature is set via the external thermostat and the thermostatic valves of the radiators in each room.
 - The heating demand signal from the external thermostat is connected to the digital input on the indoor unit (X2M/1a and X2M/4). The indoor unit will only supply the desired additional leaving water temperature when there is an actual demand.

Configuration

Setting	Value
Unit temperature control: • #: [A.2.1.7] • Code: [C-07]	2 (RT control): Unit operation is decided based on the ambient temperature of the user interface. Note: • Main room = user interface used as room thermostat functionality • Other rooms = external room thermostat functionality
Number of water temperature zones: • #: [A.2.1.8] • Code: [7-02]	1 (2 LWT zones): Main + additional

Setting	Value
In case of heat pump convectors: External room thermostat for the additional zone: • #: [A.2.2.5] • Code: [C-06]	1 (Thermo ON/OFF): When the used external room thermostat or heat pump convector can only send a thermo ON/OFF condition.
Shut-off valve output	Set to follow the thermo demand of the main zone.

Benefits

- **Comfort.** The smart room thermostat functionality can decrease or increase the desired leaving water temperature based on the actual room temperature (modulation).
- **Efficiency.**
 - Depending on the demand, the indoor unit supplies different leaving water temperature matching the design temperature of the different heat emitters.
 - Under floor heating has the best performance with Altherma LT.

5.3 Setting up the domestic hot water tank

5.3.1 System layout – Integrated DHW tank

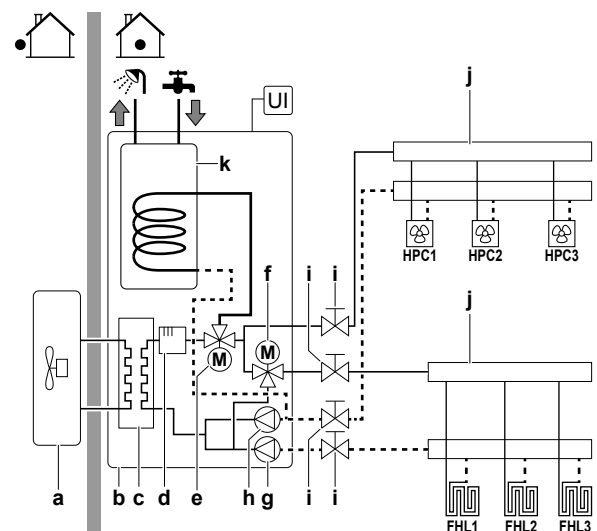

- a Outdoor unit
- b Indoor unit
- c Heat exchanger
- d Backup heater
- e Motorised 3-way valve (switch between space heating and domestic hot water)
- f Motorised 3-way valve (mixing the main zone)
- g Main pump
- h Additional pump
- i Shut-off valve
- j Collector (field supply)
- k Domestic hot water tank
- FHL1...3 Floor heating loops (field supply)
- UI User interface (field supply)
- HPC1...3 Heat pump convectors (field supply)

5.3.2 Selecting the volume and desired temperature for the DHW tank

People experience water as hot when its temperature is 40°C. Therefore, the DHW consumption is always expressed as equivalent hot water volume at 40°C. However, you can set the DHW tank temperature at a higher temperature (example: 53°C), which is then mixed with cold water (example: 15°C).

5 Application guidelines

Selecting the desired temperature for the DHW tank consists of:

- 1 Determining the DHW consumption (equivalent hot water volume at 40°C).
- 2 Determining the desired temperature for the DHW tank.

Energy saving tips

- If the DHW consumption differs from day to day, you can program a weekly schedule with different desired DHW tank temperatures for each day.
- The lower the desired DHW tank temperature, the more cost effective. By selecting a larger DHW tank, you can lower the desired DHW tank temperature.
- The heat pump itself can produce domestic hot water of maximum 55°C (50°C if outdoor temperature is low). The electrical resistance integrated in the heat pump can increase this temperature. However, this consumes more energy. Daikin recommends to set the desired DHW tank temperature below 55°C to avoid using the backup heater.
- The higher the outdoor temperature, the better the performance of the heat pump.
 - If energy prices are the same during the day and the night, Daikin recommends to heat up the DHW tank during the day.
 - If energy prices are lower during the night, Daikin recommends to heat up the DHW tank during the night.
- When the heat pump produces domestic hot water, it cannot heat up a space. When you need domestic hot water and space heating at the same, Daikin recommends to produce the domestic hot water during the night when there is lower space heating demand.

Determining the DHW consumption

Answer the following questions and calculate the DHW consumption (equivalent hot water volume at 40°C) using the typical water volumes:

Question	Typical water volume
How many showers are needed per day?	1 shower = 10 min×10 l/min = 100 l
How many baths are needed per day?	1 bath = 150 l
How much water is needed at the kitchen sink per day?	1 sink = 2 min×5 l/min = 10 l
Are there any other domestic hot water needs?	—

Example: If the DHW consumption of a family (4 persons) per day is as follows:

- 3 showers
- 1 bath
- 3 sink volumes

Then the DHW consumption = (3×100 l)+(1×150 l)+(3×10 l)=480 l

Determining the volume and desired temperature for the DHW tank

Formula	Example
$V_1 = V_2 + V_2 \times (T_2 - 40) / (40 - T_1)$	If: <ul style="list-style-type: none"> • $V_2 = 180$ l • $T_2 = 54^\circ\text{C}$ • $T_1 = 15^\circ\text{C}$ Then $V_1 = 280$ l

- V_1 DHW consumption (equivalent hot water volume at 40°C)
- V_2 Required DHW tank volume if only heated once
- T_2 DHW tank temperature
- T_1 Cold water temperature

5.3.3 Setup and configuration – DHW tank

- For large DHW consumptions, you can heat up the DHW tank several times during the day.
- To heat up the DHW tank to the desired DHW tank temperature, you can use the following energy sources:
 - Thermodynamic cycle of the heat pump
 - Electrical backup heater
- For more information about optimizing the energy consumption for producing domestic hot water, see "8 Configuration" on page 39.

5.3.4 DHW pump for instant hot water

Setup

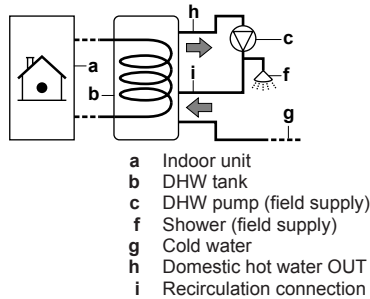

- By connecting a DHW pump, instant hot water can be available at the tap.
- The DHW pump and the installation are field supply and the responsibility of the installer.
- For more information about connecting the recirculation connection: see "7 Installation" on page 21.

Configuration

- For more information, see "8 Configuration" on page 39.
- You can program a schedule to control the DHW pump via the user interface. For more information, see the user reference guide.

5.3.5 DHW pump for disinfection

Setup

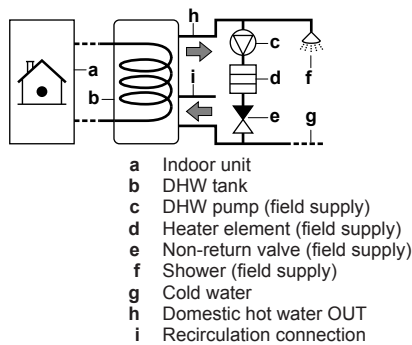

- The DHW pump is field-supplied and its installation is the responsibility of the installer.
- The temperature of the DHW tank can be set to maximum 60°C. If applicable legislation requires higher temperature for disinfection, you can connect a DHW pump and heater element as shown above.
- If applicable legislation requires disinfection of the water piping until the tapping point, you can connect a DHW pump and heater element (if needed) as shown above.
- To ensure a complete disinfection, you have to open the tapping point.



WARNING

When opening the tapping point, the water temperature can be up to 55°C.

Configuration

The indoor unit can control DHW pump operation. For more information, see "8 Configuration" on page 39.

5.4 Setting up the energy metering

- Via the user interface, you can read out the following energy data:
 - Produced heat
 - Consumed energy
- You can read out the energy data:
 - For space heating
 - For domestic hot water production
- You can read out the energy data:
 - Per month
 - Per year



INFORMATION

The calculated produced heat and consumed energy are an estimation, the accuracy cannot be guaranteed.

5.4.1 Produced heat



INFORMATION

The sensors used to calculate the produced heat are calibrated automatically.

- The produced heat is calculated internally based on:
 - The leaving and entering water temperature
 - The flow rate
- Setup and configuration: No additional equipment needed.

5.4.2 Consumed energy

You can use the following methods to determine the consumed energy:

- Calculating
- Measuring



INFORMATION

You cannot combine calculating the consumed energy (example: for backup heater) and measuring the consumed energy (example: for outdoor unit). If you do so, the energy data will be invalid.

Calculating the consumed energy

- Only applicable for EHVZ04+08.
- The consumed energy is calculated internally based on:
 - The actual power input of the outdoor unit
 - The set capacity of the backup heater
 - The voltage
- Setup and configuration: To get accurate energy data, measure the capacity (resistance measurement) and set the capacity via the user interface for the backup heater (step 1).

Measuring the consumed energy

- Applicable for all models.
- Preferred method because of higher accuracy.
- Requires external power meters.

- Setup and configuration:

- For the specifications of each type of meter, see "14 Technical data" on page 71.
- When using electrical power meters, set the number of pulses/kWh for each power meter via the user interface. Consumed energy data for EHVZ16 model will only be available if this setting is configured.



INFORMATION

When measuring the electrical power consumption, make sure ALL power input of the system is covered by the electrical power meters.

5.4.3 Normal kWh rate power supply

General rule

One power meter that covers the entire system is sufficient.

Setup

Connect the power meter to X5M/7 and X5M/8.

Power meter type

In case of...	Use a... power meter
<ul style="list-style-type: none"> • Single-phase outdoor unit • Backup heater supplied from a single-phase grid 	Single-phase
Three-phase outdoor unit	Three-phase

Example

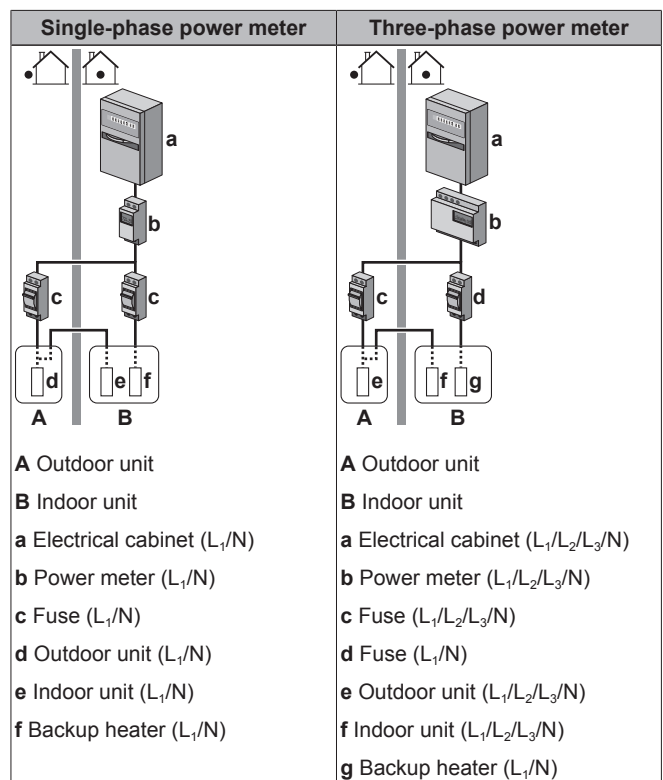

Exception

- You can use a second power meter if:
 - The power range of one meter is insufficient.
 - The electrical meter cannot easily be installed in the electrical cabinet.
 - 230 V and 400 V three-phase grids are combined (very uncommon), because of technical limitations of power meters.

5 Application guidelines

- Connection and setup:
 - Connect the second power meter to X5M/9 and X5M/10.
 - In the software the power consumption data of both meters is added so you do NOT have to set which meter covers which power consumption. You only need to set the number of pulses of each power meter.
- See "5.4.4 Preferential kWh rate power supply" on page 14 for an example with two power meters.

5.4.4 Preferential kWh rate power supply

General rule

- Power meter 1: Measures the outdoor unit.
- Power meter 2: Measures the rest (i.e. indoor unit and backup heater).

Setup

- Connect power meter 1 to X5M/7 and X5M/8.
- Connect power meter 2 to X5M/9 and X5M/10.

Power meter types

- Power meter 1: Single- or three-phase power meter according to the power supply of the outdoor unit.
- Power meter 2: Use a single-phase power meter.

5.5 Setting up the power consumption control

- The power consumption control:
 - Is only applicable for EHVZ04+08.
 - Allows you to limit the power consumption of the entire system (sum of outdoor unit, indoor unit and backup heater).
 - Configuration: Set the power limitation level and how it has to be achieved via the user interface.
- The power limitation level can be expressed as:
 - Maximum running current (in A)
 - Maximum power input (in kW)
- The power limitation level can be activated:
 - Permanently
 - By digital inputs

5.5.1 Permanent power limitation

Permanent power limitation is useful to assure a maximum power or current input of the system. In some countries, legislation limits the maximum power consumption for space heating and DHW production.

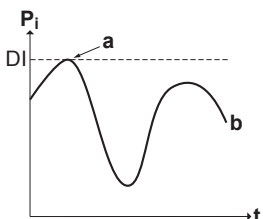

P_i Power input
 t Time
 DI Digital input (power limitation level)
 a Power limitation active
 b Actual power input

Setup and configuration

- No additional equipment needed.

- Set the power consumption control settings in [A.6.3.1] via the user interface (for the description of all settings, see "8 Configuration" on page 39):
 - Select full time limitation mode
 - Select the type of limitation (power in kW or current in A)
 - Set the desired power limitation level



NOTICE

Mind the following guidelines when selecting the desired power limitation level:

- Set a minimum power consumption of ± 3.6 kW to guarantee defrost operation. Otherwise, if defrosting is interrupted several times, the heat exchanger will freeze up.
- Set a minimum power consumption of ± 3 kW to guarantee space heating and DHW production by allowing the backup heater step 1.

5.5.2 Power limitation activated by digital inputs

Power limitation is also useful in combination with an energy management system.

The power or current of the entire Daikin system is limited dynamically by digital inputs (maximum four steps). Each power limitation level is set via the user interface by limiting one of the following:

- Current (in A)
- Power input (in kW)

The energy management system (field supply) decides the activation of a certain power limitation level. **Example:** To limit the maximum power of the entire house (lighting, domestic appliances, space heating...).

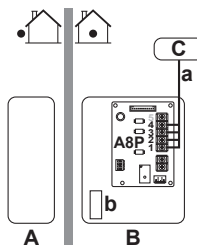

A Outdoor unit
 B Indoor unit
 C Energy management system
 a Power limitation activation (4 digital inputs)
 b Backup heater

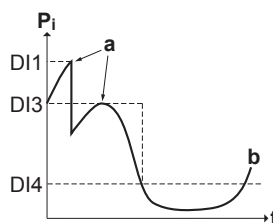

P_i Power input
 t Time
 DI Digital inputs (power limitation levels)
 a Power limitation active
 b Actual power input

Setup

- Demand PCB (option EKR1AHTA) needed.

- Maximum four digital inputs are used to activate the corresponding power limitation level:
 - DI1 = weakest limitation (highest energy consumption)
 - DI4 = strongest limitation (lowest energy consumption)
- For the specifications of the digital inputs, and for where to connect them, refer to the wiring diagram.

Configuration

Set the power consumption control settings in [A.6.3.1] via the user interface (for the description of all settings, see "8 Configuration" on page 39):

- Select activation by digital inputs.
- Select the type of limitation (power in kW or current in A).
- Set the desired power limitation level corresponding to each digital input.



INFORMATION

In case more than 1 digital input is closed (at the same time), the digital input priority is fixed: DI4 priority > ... > DI1.

5.5.3 Power limitation process

The outdoor unit has better efficiency than the electrical heater. Therefore, the electrical heater is limited and turned OFF first. The system limits power consumption in the following order:

- Turns OFF the backup heater.
- Limits the outdoor unit.
- Turns OFF the outdoor unit.

Example

If the configuration is as follows: Power limitation level does NOT allow operation of backup heater (step 1).

Then power consumption is limited as follows:

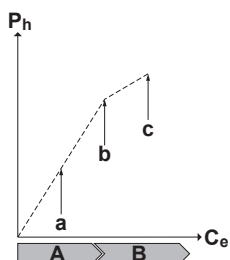

- P_h Produced heat
- C_e Consumed energy
- A** Outdoor unit
- B** Backup heater
- a** Limited outdoor unit operation
- b** Full outdoor unit operation
- c** Backup heater step 1 turned ON

5.6 Setting up an external temperature sensor

You can connect one external temperature sensor. It can measure the indoor or outdoor ambient temperature. Daikin recommends to use an external temperature sensor in the following cases:

Indoor ambient temperature

- In room thermostat control, the user interface is used as room thermostat and it measures the indoor ambient temperature. Therefore, the user interface must be installed on a location:
 - Where the average temperature in the room can be detected
 - That is NOT exposed to direct sunlight
 - That is NOT near a heat source
 - That is NOT affected by outside air or air draught because of, for example, door opening/closing
- If this is NOT possible, Daikin recommends to connect a remote indoor sensor (option KRCS01-1).
- Setup: For installation instructions, see the installation manual of the remote indoor sensor.
- Configuration: Select room sensor [A.2.2.B].

Outdoor ambient temperature

- In the outdoor unit, the outdoor ambient temperature is measured. Therefore, the outdoor unit must be installed on a location:
 - At the north side of the house or at the side of the house where the most heat emitters are located
 - That is NOT exposed to direct sunlight
- If this is NOT possible, Daikin recommends to connect a remote outdoor sensor (option EKRSCA1).
- Setup: For installation instructions, see the installation manual of the remote outdoor sensor.
- Configuration: Select outdoor sensor [A.2.2.B].
- During suspend (see "8 Configuration" on page 39), the outdoor unit is turned down to reduce the standby energy losses. As a result, the outdoor ambient temperature is NOT read out.
- If the desired leaving water temperature is weather dependent, the full time outdoor temperature measurement is important. This is another reason to install the optional outdoor ambient temperature sensor.



INFORMATION

The external outdoor ambient sensor data (either averaged or instantaneous) is used in the weather-dependent control curves. To protect the outdoor unit, the internal sensor of the outdoor unit is always used.

6 Preparation

6.1 Overview: Preparation

This chapter describes what you have to do and know before going on-site.

It contains information about:

- Preparing the installation site
- Preparing the refrigerant piping
- Preparing the water piping
- Preparing the electrical wiring

6.2 Preparing installation site

Do NOT install the unit in places often used as work place. In case of construction works (e.g. grinding works) where a lot of dust is created, the unit must be covered.

Choose the installation location with sufficient place for carrying the unit in and out of the site.

6 Preparation

NOTICE

This unit is designed for operation on 2 temperature zones:

- underfloor heating in the **main zone** (water temperature 35°C), this is the zone with the **lowest water temperature**,
- radiators in the **additional zone** (water temperature 45°C), this is the zone with the **highest water temperature**.

6.2.1 Installation site requirements of the outdoor unit

INFORMATION

Also read the following requirements:

- General installation site requirements. See the "General safety precautions" chapter.
- Service space requirements. See the "Technical data" chapter.
- Refrigerant piping requirements (length, height difference). See further in this "Preparation" chapter.

See "14.2 Dimensions and service space" on page 71 for more detailed information about spacing guidelines.

- Select a place where rain can be avoided as much as possible.
- Take care that in the event of a water leak, water cannot cause any damage to the installation space and surroundings.

Do NOT install the unit in the following places:

- Sound sensitive areas (e.g. near a bedroom and the like), so that the operation noise will cause no trouble.
Note: If the sound is measured under actual installation conditions, the measured value might be higher than the sound pressure level mentioned in Sound spectrum in the data book due to environmental noise and sound reflections.
- In places where a mineral oil mist, spray or vapour may be present in the atmosphere. Plastic parts may deteriorate and fall off or cause water leakage.

It is NOT recommended to install the unit in the following places because it may shorten the life of the unit:

- in coastal areas or other places where the air contains high levels of salt. Corrosion may occur,
- where the voltage fluctuates a lot,
- in vehicles or vessels,
- where acidic or alkaline vapour is present.

Strong winds (≥ 18 km/h) blowing against the outdoor unit's air outlet causes short circuit (suction of discharge air). This may result in:

- deterioration of the operational capacity;
- frequent frost acceleration in heating operation;
- disruption of operation due to decrease of low pressure or increase of high pressure;
- a broken fan (if a strong wind blows continuously on the fan, it may start rotating very fast, until it breaks).

It is recommended to install a baffle plate when the air outlet is exposed to wind.

It is recommended to install the outdoor unit with the air inlet facing the wall and NOT directly exposed to the wind.

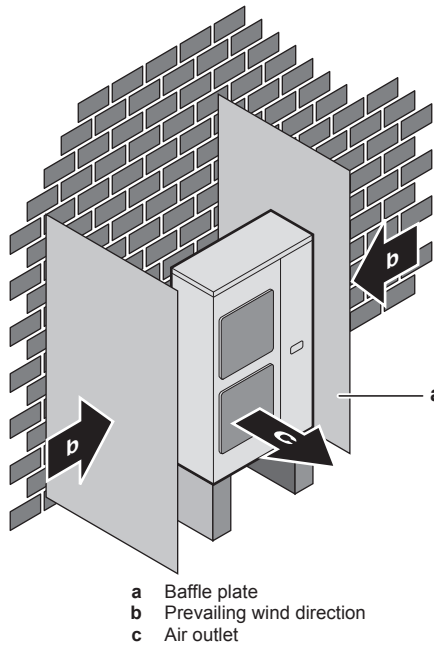

- a Baffle plate
- b Prevailing wind direction
- c Air outlet

The outdoor unit is designed for outdoor installation only, and for ambient temperatures ranging 10~43°C in cooling mode and -25~25°C in heating mode.

6.2.2 Additional installation site requirements of the outdoor unit in cold climates

Protect the outdoor unit against direct snowfall and take care that the outdoor unit is NEVER snowed up.

INFORMATION

You can use the optional snow cover (EK016SNC).

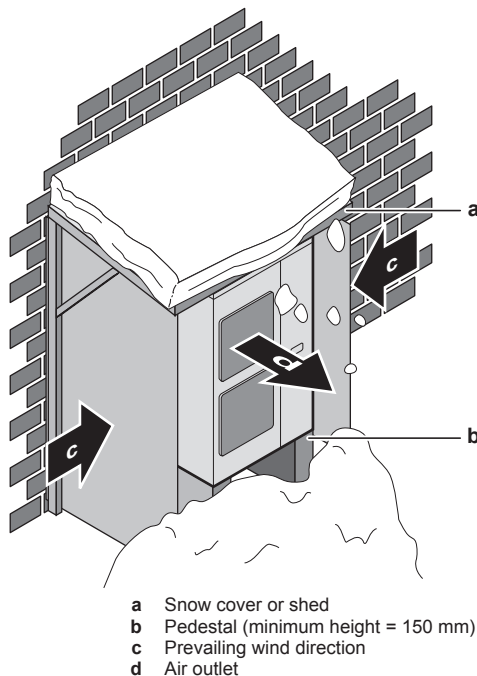

- a Snow cover or shed
- b Pedestal (minimum height = 150 mm)
- c Prevailing wind direction
- d Air outlet

6.2.3 Installation site requirements of the indoor unit

INFORMATION

Also read the precautions and requirements in the "General safety precautions" chapter.

- Mind the measurement guidelines:

Maximum refrigerant piping length between indoor unit and outdoor unit	ERHQ: 75 m (95 m) ^(a) ERLQ: 50 m (70 m) ^(a)
Minimum refrigerant piping length between indoor unit and outdoor unit	3 m
Maximum height difference between indoor unit and outdoor unit	30 m

(a) Parenthesised figure represents the equivalent length.

- Mind the following spacing installation guidelines:

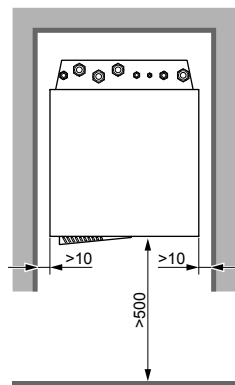

(mm)

Do NOT install the unit in places such as:

- In places where a mineral oil mist, spray or vapour may be present in the atmosphere. Plastic parts may deteriorate and fall off or cause water leakage.
- Sound sensitive areas (e.g. near a bedroom and the like), so that the operation noise will cause no trouble.
- The foundation must be strong enough to bear the weight of the unit. Take the weight of the unit with a domestic hot water tank full of water into account. Make sure, in the event of a water leak, water cannot cause any damage to the installation space and surroundings.
- In places with high humidity (max. RH=85%), for example a bathroom.
- In places where frost is possible. Ambient temperature around the indoor unit should be >5°C.
- The indoor unit is designed for indoor installation only and for ambient temperatures ranging from 5~35°C.

6.3 Preparing refrigerant piping

6.3.1 Refrigerant piping requirements



INFORMATION

Also read the precautions and requirements in the "General safety precautions" chapter.

- Piping material:** Phosphoric acid deoxidised seamless copper.
- Piping diameter:**

Liquid piping	Ø9.5 mm (3/8")
Gas piping	Ø15.9 mm (5/8")

- Piping temper grade and thickness:**

Outer diameter (Ø)	Temper grade	Thickness (t) ^(a)	
9.5 mm (3/8")	Annealed (O)	≥0.8 mm	
15.9 mm (5/8")	Annealed (O)	≥1.0 mm	

- (a) Depending on the applicable legislation and the unit's maximum working pressure (see "PS High" on the unit name plate), larger piping thickness might be required.

6.3.2 Refrigerant piping insulation

- Use polyethylene foam as insulation material:
 - with a heat transfer rate between 0.041 and 0.052 W/mK (0.035 and 0.045 kcal/mh°C)
 - with a heat resistance of at least 120°C
- Insulation thickness

Ambient temperature	Humidity	Minimum thickness
≤30°C	75% to 80% RH	15 mm
>30°C	≥80% RH	20 mm

6.4 Preparing water piping

6.4.1 Water circuit requirements



INFORMATION

Also read the precautions and requirements in the "General safety precautions" chapter.

- Connecting piping – Legislation.** Make all piping connections in accordance with the applicable legislation and the instructions in the "Installation" chapter, respecting the water inlet and outlet.
- Connecting piping – Force.** Do NOT use excessive force when connecting the piping. Deformation of the piping can cause malfunctioning of the unit.
- Connecting piping – Tools.** Only use appropriate tooling to handle brass, which is a soft material. If NOT, pipes will get damaged.
- Connecting piping – Air, moisture, dust.** If air, moisture or dust gets into the circuit, problems may occur. To prevent this:
 - Only use clean pipes
 - Hold the pipe end downwards when removing burrs.
 - Cover the pipe end when inserting it through a wall, to prevent dust and/or particles entering the pipe.
 - Use a decent thread sealant to seal connections.
- Closed circuit.** Use the indoor unit ONLY in a closed water system. Using the system in an open water system will lead to excessive corrosion.
- Glycol.** For safety reasons, it is NOT allowed to add any kind of glycol to the water circuit.
- Piping length.** It is recommended to avoid long runs of piping between the domestic hot water tank and the hot water end point (shower, bath,...) and to avoid dead ends.
- Piping diameter.** Select the water piping diameter in relation to the required water flow and the available external static pressure of the pump. See "14 Technical data" on page 71 for the external static pressure curves of the indoor unit.
- Water flow.** You can find the minimum required water flow for indoor unit operation in the following table. In all cases, this flow needs to be guaranteed. When the flow is lower, the indoor unit will stop operation and display error 7H.

Minimum required flow rate during defrost/backup heater operation	
04+08 models	12 l/min
16 model	15 l/min

6 Preparation

- **Field supply components – Water.** Only use materials that are compatible with water used in the system and with the materials used in the indoor unit.
- **Field supply components – Water pressure and temperature.** Check that all components in the field piping can withstand the water pressure and water temperature.
- **Water pressure.** The maximum water pressure is 4 bar. Provide adequate safeguards in the water circuit to ensure that the maximum pressure is NOT exceeded.
- **Water temperature.** All installed piping and piping accessories (valve, connections,...) MUST withstand the following temperatures:

INFORMATION

The following illustration is an example and might NOT match your system layout.

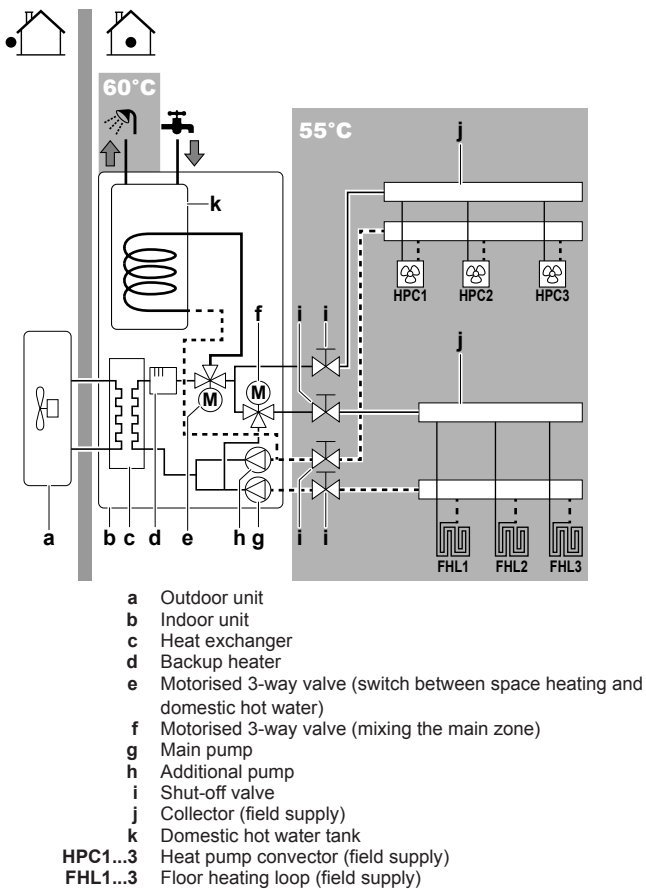

- **Drainage – Low points.** Provide drain taps at all low points of the system in order to allow complete drainage of the water circuit.
- **Drainage – Pressure relief valve.** Provide a proper drain for the pressure relief valve to avoid water dripping out of the unit. See ["7.8.5 To connect the pressure relief valve to the drain" on page 31.](#)
- **Air vents.** Provide air vents at all high points of the system, which must also be easily accessible for servicing. An automatic air purge is provided in the indoor unit. Check that the air purge is NOT tightened too much, so that automatic release of air in the water circuit is possible.
- **Zn-coated parts.** Never use Zn-coated parts in the water circuit. Because the unit's internal water circuit uses copper piping, excessive corrosion may occur.
- **Non-brass metallic piping.** When using non-brass metallic piping, insulate the brass and non-brass properly so that they do NOT make contact with each other. This to prevent galvanic corrosion.

- **Valve – Change-over time.** When using a 2-way valve or a 3-way valve in the water circuit, the maximum change-over time of the valve must be 60 seconds.
- **Filter.** It is strongly recommended to install an additional filter on both heating water circuits. Especially to remove metallic particles from foul heating piping, it is recommended to use a magnetic or cyclone filter, which can remove small particles. Small particles may damage the unit and will NOT be removed by the standard filter of the heat pump system.
- **Domestic hot water tank – Capacity.** To avoid stagnation of water, it is important that the storage capacity of the domestic hot water tank meets the daily consumption of domestic hot water.
- **Domestic hot water tank – After installation.** Immediately after installation, the domestic hot water tank must be flushed with fresh water. This procedure must be repeated at least once a day the first 5 consecutive days after installation.
- **Domestic hot water tank – Standstills.** In cases where during longer periods of time there is no consumption of hot water, the equipment MUST be flushed with fresh water before usage.
- **Domestic hot water tank – Disinfection.** For the disinfection function of the domestic hot water tank, see ["8.3.2 Domestic hot water control: advanced" on page 51.](#)
- **Thermostatic mixing valves.** In accordance with the applicable legislation, it may be necessary to install thermostatic mixing valves.
- **Hygienic measures.** The installation must be in compliance with the applicable legislation and may require additional hygienic installation measures.
- **Recirculation pump.** In accordance with the applicable legislation, it may be required to connect a recirculation pump in between the hot water end point and the recirculation connection of the domestic hot water tank.

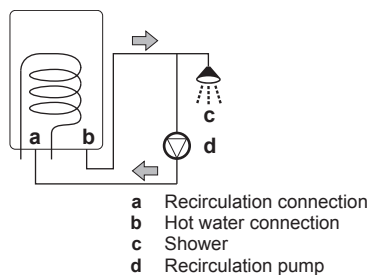

6.4.2 Formula to calculate the expansion vessel pre-pressure

The pre-pressure (P_g) of the vessel depends on the installation height difference (H):

$$P_g = 0.3 + (H/10) \text{ (bar)}$$

6.4.3 To check the water volume and flow rate

The indoor unit has an expansion vessel of 10 litre with a factory set pre-pressure of 1 bar.

To make sure that the unit operates properly:

- You must check the minimum and maximum water volume.
- You might need to adjust the pre-pressure of the expansion vessel.

Minimum water volume

Check that the total water volume in the installation is minimum 10 litre for EHVZ04+08 and 20 litre for EHVZ16, the internal water volume of the indoor unit NOT included. Do **NOT** split up the minimum water volume over the 2 temperature zones.

It is sufficient to foresee the minimum water volume on the main zone. In case of underfloor heating, this is easily done by 1 floor heating loop that never will be closed by a (remotely) controlled valve.

It is NOT required to foresee the minimum water volume on the additional zone.

i INFORMATION

In critical processes, or in rooms with a high heat load, extra water might be required.

! NOTICE

When circulation in each space heating loop is controlled by remotely controlled valves, it is important that the minimum water volume is guaranteed, even if all of the valves are closed.

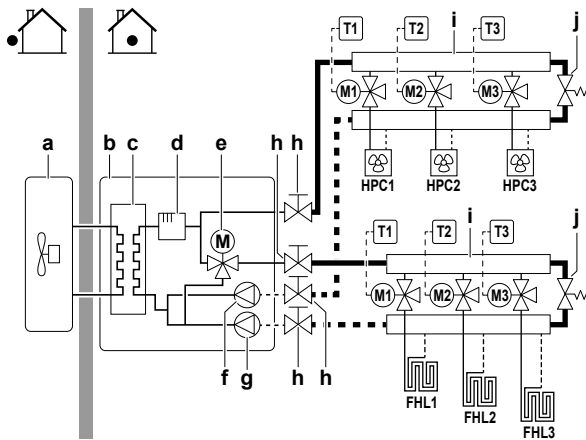

- a Outdoor unit
- b Indoor unit
- c Heat exchanger
- d Backup heater
- e Motorised 3-way valve (mixing the main zone)
- f Additional pump
- g Main pump
- h Shut-off valve
- i Collector (field supply)
- j By-pass valve (field supply)
- FHL1...3 Floor heating loop (field supply)
- HPC1...3 Heat pump convector (field supply)
- T1...3 Individual room thermostat (optional)
- M1...3 Individual motorised valve to control loop FHL1...3 and HPC1...3 (field supply)

Maximum water volume

Use the following graph to determine the maximum water volume for the calculated pre-pressure.

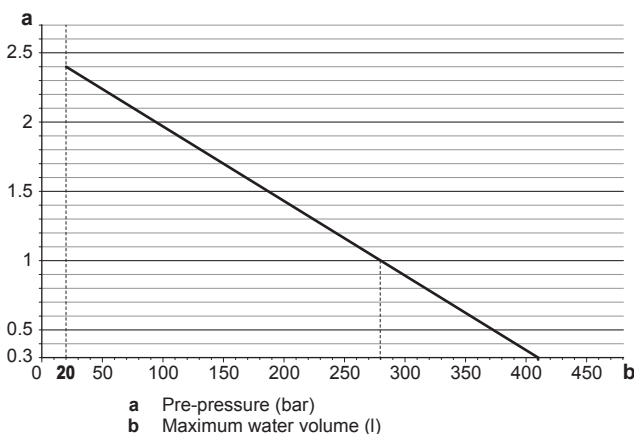

Example: Maximum water volume and expansion vessel pre-pressure

Installation height difference ^(a)	Water volume	
	≤280 l	>280 l
≤7 m	No pre-pressure adjustment is required.	Do the following: <ul style="list-style-type: none"> Decrease the pre-pressure. Check if the water volume does NOT exceed the maximum allowed water volume.
>7 m	Do the following: <ul style="list-style-type: none"> Increase the pre-pressure. Check if the water volume does NOT exceed the maximum allowed water volume. 	The expansion vessel of the indoor unit is too small for the installation. In this case, it is recommended to install an extra vessel outside the unit.

(a) This is the height difference (m) between the highest point of the water circuit and the indoor unit. If the indoor unit is at the highest point of the installation, the installation height is 0 m.

Minimum flow rate

Check that the minimum flow rate (required during defrost/backup heater operation) in the installation is guaranteed in all conditions on each zone separately.

! NOTICE

When circulation in each or certain space heating loops is controlled by remotely controlled valves, it is important that the minimum flow rate is guaranteed, even if all valves are closed. In case the minimum flow rate cannot be reached, a flow error 7H will be generated (no heating/operation).

Minimum required flow rate during defrost/backup heater operation	
04+08 models	12 l/min
16 model	15 l/min

See the recommended procedure as described in "9.4 Checklist during commissioning" on page 60.

6.4.4 Changing the pre-pressure of the expansion vessel

! NOTICE

Only a licensed installer may adjust the pre-pressure of the expansion vessel.

When changing the default pre-pressure of the expansion vessel (1 bar) is required, take following guidelines into account:

- Only use dry nitrogen to set the expansion vessel pre-pressure.
- Inappropriate setting of the expansion vessel pre-pressure will lead to malfunction of the system.

Changing the pre-pressure of the expansion vessel should be done by releasing or increasing nitrogen pressure through the schröder valve of the expansion vessel.

6 Preparation

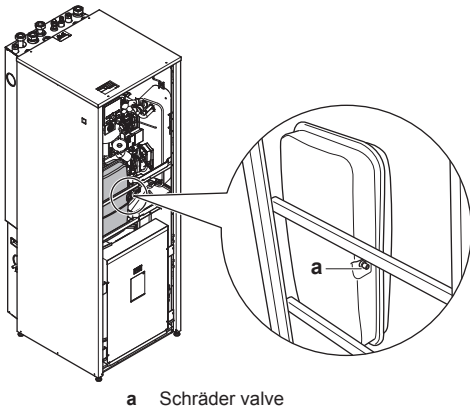

a Schrader valve

6.4.5 To check the water volume: Examples

Example 1

The indoor unit is installed 5 m below the highest point in the water circuit. The total water volume in the water circuit is 100 l.

No actions or adjustments are required.

Example 2

The indoor unit is installed at the highest point in the water circuit. The total water volume in the water circuit is 350 l.

Actions:

- Because the total water volume (350 l) is more than the default water volume (280 l), the pre-pressure must be decreased.
- The required pre-pressure is:
 $P_g = (0.3 + (H/10)) \text{ bar} = (0.3 + (0/10)) \text{ bar} = 0.3 \text{ bar}$.
- The corresponding maximum water volume at 0.3 bar is 410 l. (See the graph in the chapter above).
- Because 350 l is lower than 410 l, the expansion vessel is appropriate for the installation.

6.5 Preparing electrical wiring

6.5.1 About preparing electrical wiring



INFORMATION

Also read the precautions and requirements in the "General safety precautions" chapter.



INFORMATION

Also read "[7.9.5 Specifications of standard wiring components](#)" on page 33.



WARNING

- If the power supply has a missing or wrong N-phase, equipment might break down.
- Establish proper earthing. Do NOT earth the unit to a utility pipe, surge absorber, or telephone earth. Incomplete earthing may cause electrical shock.
- Install the required fuses or circuit breakers.
- Secure the electrical wiring with cable ties so that the cables do NOT come in contact with sharp edges or piping, particularly on the high-pressure side.
- Do NOT use taped wires, stranded conductor wires, extension cords, or connections from a star system. They can cause overheating, electrical shock or fire.
- Do NOT install a phase advancing capacitor, because this unit is equipped with an inverter. A phase advancing capacitor will reduce performance and may cause accidents.



WARNING

- All wiring must be performed by an authorized electrician and must comply with the applicable legislation.
- Make electrical connections to the fixed wiring.
- All components procured on the site and all electrical construction must comply with the applicable legislation.



WARNING

The backup heater should have a dedicated power supply.



WARNING

ALWAYS use multicore cable for power supply cables.

6.5.2 About preferential kWh rate power supply



NOTICE

For applications with preferential kWh rate power supply:

The interruption of the outdoor unit power supply may not be more than 2 hours to guarantee optimised startup conditions for the compressor.

Electricity companies throughout the world work hard to provide reliable electric service at competitive prices and are often authorized to bill clients at benefit rates. E.g. time-of-use rates, seasonal rates, Wärmepumpentarif in Germany and Austria, ...

This equipment allows for connection to such preferential kWh rate power supply delivery systems.

Consult with the electricity company acting as provider at the site where this equipment is to be installed to know whether it is appropriate to connect the equipment in one of the preferential kWh rate power supply delivery systems available, if any.

When the equipment is connected to such preferential kWh rate power supply, the electricity company is allowed to:

- interrupt power supply to the equipment for certain periods of time;
- demand that the equipment only consumes a limited amount of electricity during certain periods of time.

The indoor unit is designed to receive an input signal by which the unit switches into forced off mode. At that moment, the outdoor unit compressor will not operate.

Whether the power supply is interrupted or not, the wiring to the unit is different.

Overview of electrical connections except external actuators

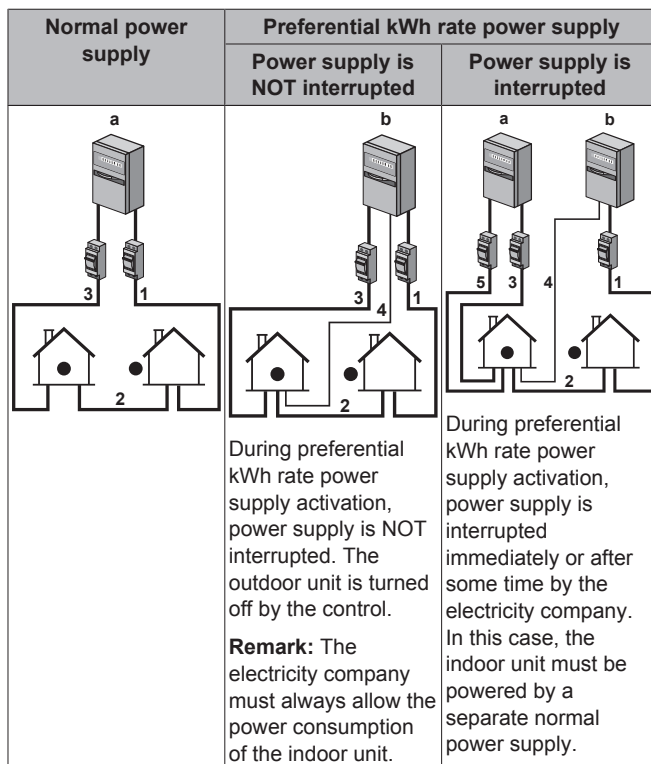

- a Normal power supply
- b Preferential kWh rate power supply
- 1 Power supply for outdoor unit
- 2 Power supply and interconnection cable to indoor unit
- 3 Power supply for backup heater
- 4 Preferential kWh rate power supply (voltage free contact)
- 5 Normal kWh rate power supply (to power the indoor unit PCB in the event of power supply interruption of the preferential kWh rate power supply)

6.5.3 Overview of electrical connections for external and internal actuators

The following illustration shows the required field wiring.

i INFORMATION

The following illustration is an example and might NOT match your system layout.

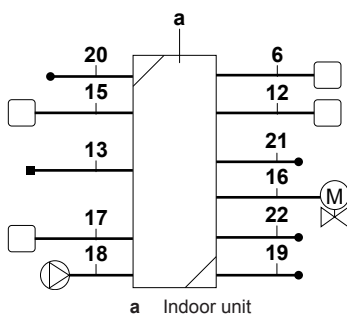

Item	Description	Wires	Maximum running current
Outdoor unit and indoor unit power supply			
1	Power supply for outdoor unit	2+GND or 3+GND	(a)
2	Power supply and interconnection cable to indoor unit	3	(c)
3	Power supply for backup heater	See table below.	—

Item	Description	Wires	Maximum running current
4	Preferential kWh rate power supply (voltage free contact)	2	(d)
5	Normal kWh rate power supply	2	6.3 A
User interface			
6	User interface	2	(e)
Optional equipment			
11	Power supply for bottom plate heater	2	(b)
12	Room thermostat	2 or 3	100 mA ^(b)
13	Outdoor ambient temperature sensor	2	(b)
14	Indoor ambient temperature sensor	2	(b)
15	Heat pump convector	2	100 mA ^(b)
Field supplied components			
16	Shut-off valve	2	100 mA ^(b)
17	Electricity meter	2 (per meter)	(b)
18	Domestic hot water pump	2	(b)
19	Alarm output	2	(b)
20	Changeover to external heat source control	2	(b)
21	Space heat operation control	2	(b)
22	Power consumption digital inputs	2 (per input signal)	(b)
23	Safety thermostat	2	(b)

- (a) Refer to name plate on outdoor unit.
- (b) Minimum cable section 0.75 mm².
- (c) Cable section 2.5 mm².
- (d) Cable section 0.75 mm² till 1.25 mm²; maximum length: 50 m. Voltage-free contact shall ensure the minimum applicable load of 15 V DC, 10 mA.
- (e) Cable section 0.75 mm² till 1.25 mm²; maximum length: 500 m. Applicable for both single user interface and dual use interface connection.



NOTICE

More technical specifications of the different connections are indicated on the inside of the indoor unit.



NOTICE

A safety thermostat (normal closed contact) MUST be installed. See "7.9.17 To connect the safety thermostat (normal closed contact)" on page 38.

Backup heater type	Power supply	Required number of conductors
*3V	1× 230 V	2+GND

7 Installation

7.1 Overview: Installation

This chapter describes what you have to do and know on-site to install the system.

7 Installation

Typical workflow

Installation typically consists of the following stages:

- 1 Mounting the outdoor unit.
- 2 Mounting the indoor unit.
- 3 Connecting the refrigerant piping.
- 4 Checking the refrigerant piping.
- 5 Charging refrigerant.
- 6 Connecting the water piping.
- 7 Connecting the electrical wiring.
- 8 Finishing the outdoor installation.
- 9 Finishing the indoor installation.

INFORMATION

Depending on the units and/or the installation conditions, it might be necessary to connect electrical wiring before you can charge refrigerant.

7.2 Opening the units

7.2.1 About opening the units

At certain times, you have to open the unit. **Example:**

- When connecting the refrigerant piping
- When connecting the electrical wiring
- When maintaining or servicing the unit

DANGER: RISK OF ELECTROCUTION

Do NOT leave the unit unattended when the service cover is removed.

7.2.2 To open the outdoor unit

DANGER: RISK OF ELECTROCUTION

DANGER: RISK OF BURNING

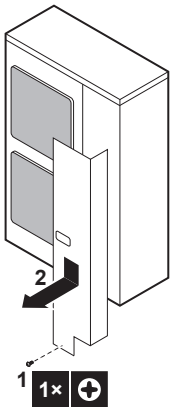

7.2.3 To open the indoor unit

- 1 Loosen and remove the screws at the bottom of the unit.
- 2 Push on the button at the bottom of the front plate.

WARNING: Sharp edges

Take the front plate on the upper part instead of the lower part. Watch your fingers, there are sharp edges on the lower part of the front plate.

- 3 Slide the front panel of the unit downwards and remove it.

CAUTION

The front panel is heavy. Be careful NOT to jam your fingers when opening or closing the unit.

- 4 Loosen and remove the 4 screws that fix the top panel.
- 5 Remove the top panel from the unit.

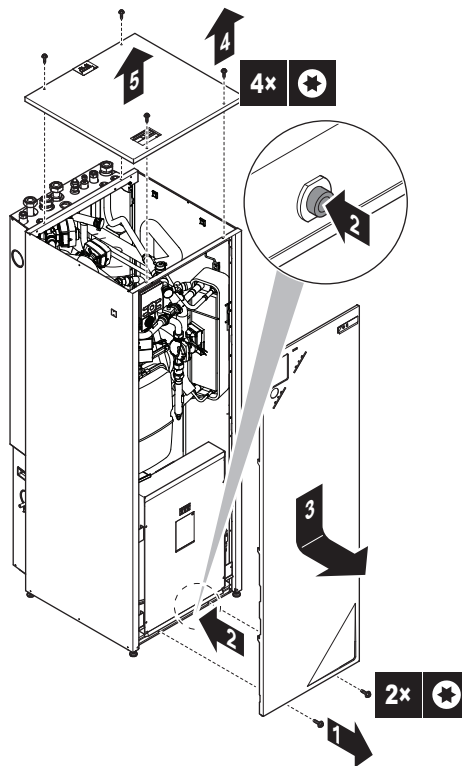

7.2.4 To open the switch box cover of the indoor unit

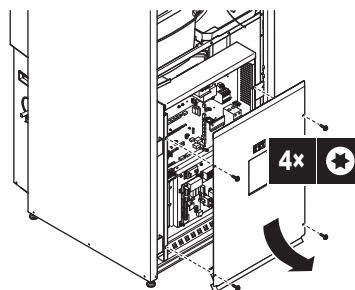

7.3 Mounting the outdoor unit

7.3.1 About mounting the outdoor unit

When

You have to mount the outdoor and indoor unit before you can connect the refrigerant and water piping.

Typical workflow

Mounting the outdoor unit typically consists of the following stages:

- 1 Providing the installation structure.
- 2 Installing the outdoor unit.
- 3 Providing drainage.
- 4 Preventing the outdoor unit from falling over.
- 5 Protecting the unit against snow and wind by installing a snow cover and baffle plates. See "Preparing installation site" in ["6 Preparation" on page 15](#).

7.3.2 Precautions when mounting the outdoor unit



INFORMATION

Also read the precautions and requirements in the following chapters:

- General safety precautions
- Preparation

7.3.3 To provide the installation structure

Check the strength and level of the installation ground so that the unit will not cause any operating vibration or noise.

Fix the unit securely by means of foundation bolts in accordance with the foundation drawing.

Prepare 4 sets of anchor bolts, nuts and washers (field supply) as follows:

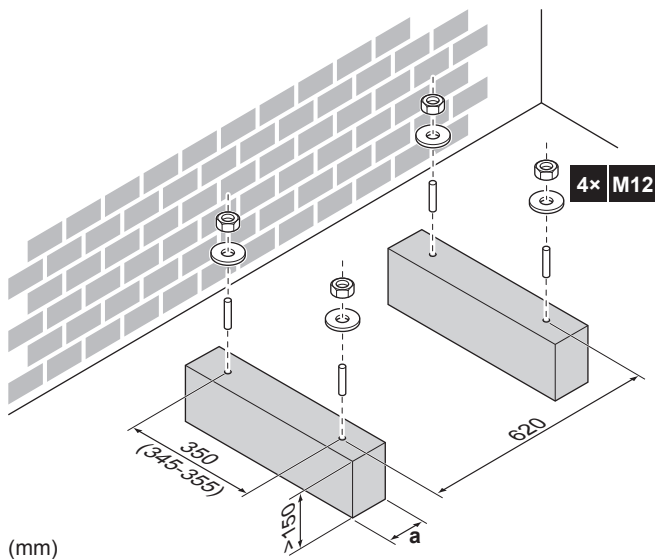

a Make sure not to cover the drain holes.



INFORMATION

The recommended height of the upper protruding part of the bolts is 20 mm.

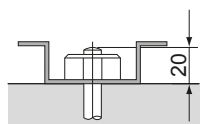

NOTICE

Fix the outdoor unit to the foundation bolts using nuts with resin washers (a). If the coating on the fastening area is stripped off, the nuts rust easily.



7.3.4 To install the outdoor unit

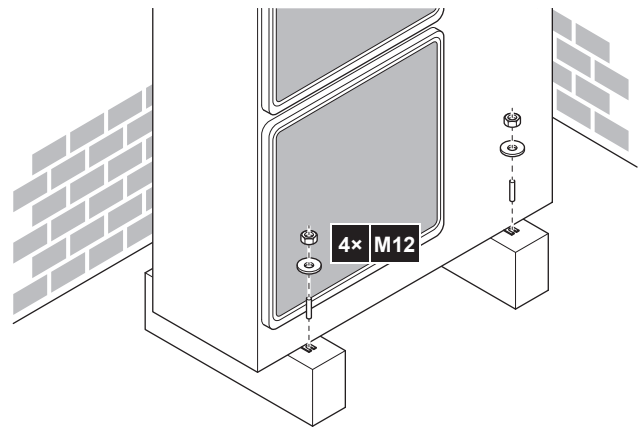

7.3.5 To provide drainage

- Make sure that condensation water can be evacuated properly.
- Install the unit on a base to make sure that there is a proper drainage in order to avoid ice accumulation.
- Prepare a water drainage channel around the foundation to drain waste water surrounding the unit.
- Avoid drain water flowing over the footpath, so that it does not become slippery in case of ambient freezing temperatures.
- If you install the unit on a frame, install a waterproof plate within 150 mm of the bottom side of the unit in order to prevent the invasion of water in the unit and to avoid the drain water dripping (see the following illustration).

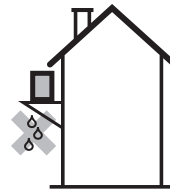

INFORMATION

You can use the optional drain plug kit (EKDK04) (only for ERHQ).



NOTICE

If drain holes of the outdoor unit are covered by a mounting base or by floor surface, raise the unit to provide a free space of more than 150 mm under the outdoor unit.

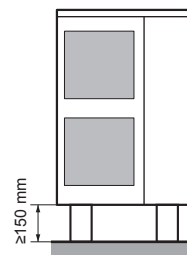

Drain holes

Model	Bottom view (mm)
ERHQ_V3	

7 Installation

Model	Bottom view (mm)
ERHQ_W1	
ERLQ	

- a Discharge side
- b Drain holes
- c Knockout hole (piping intake - downwards route)
- d Anchor points

7.3.6 To prevent the outdoor unit from falling over

In case the unit is installed in places where strong wind can tilt the unit, take following measure:

Connect cables (field supply) as shown.

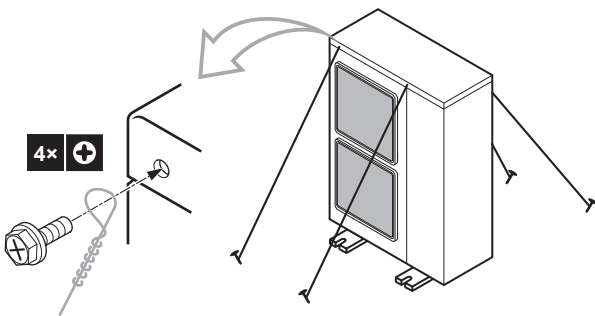

7.4 Mounting the indoor unit

7.4.1 About mounting the indoor unit

When

You have to mount the outdoor and indoor unit before you can connect the refrigerant and water piping.

Typical workflow

Mounting the indoor unit typically consists of the following stages:

- 1 Installing the indoor unit.

7.4.2 Precautions when mounting the indoor unit



INFORMATION

Also read the precautions and requirements in the following chapters:

- General safety precautions
- Preparation

7.4.3 To install the indoor unit

- 1 Lift the indoor unit from the pallet and place it on the floor.

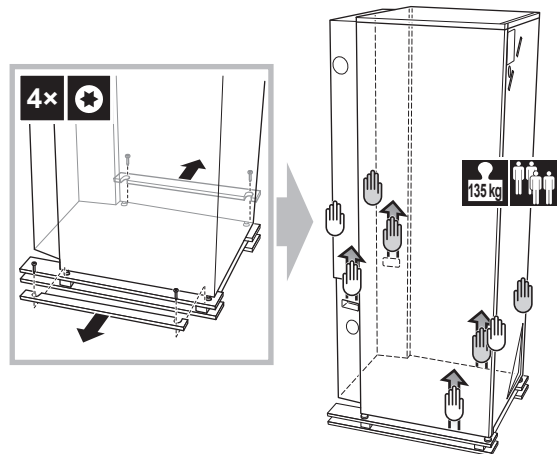

- 2 Slide the indoor unit into position.
- 3 Adjust the height of the leveling feet to compensate for floor irregularities. The maximum allowed deviation is 1°.

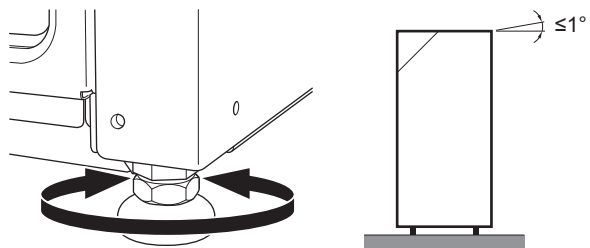

NOTICE

Do NOT tilt the unit backwards:

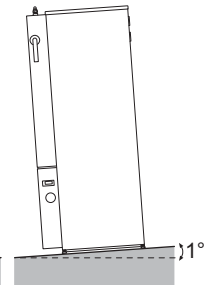
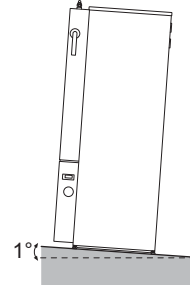
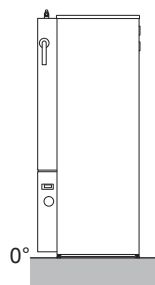

7.5 Connecting the refrigerant piping

7.5.1 About connecting the refrigerant piping

Before connecting the refrigerant piping

Make sure the outdoor and indoor unit are mounted.

Typical workflow

Connecting the refrigerant piping involves:

- Connecting the refrigerant piping to the outdoor unit
- Connecting the refrigerant piping to the indoor unit
- Installing oil traps
- Insulating the refrigerant piping

- Keeping in mind the guidelines for:
 - Pipe bending
 - Flaring pipe ends
 - Brazing
 - Using the stop valves

7.5.2 Precautions when connecting the refrigerant piping



INFORMATION

Also read the precautions and requirements in the following chapters:

- General safety precautions
- Preparation



DANGER: RISK OF BURNING



CAUTION

- Do NOT use mineral oil on flared part.
- Do NOT reuse piping from previous installations.
- NEVER install a drier to this R410A unit to guarantee its lifetime. The drying material may dissolve and damage the system.



NOTICE

Take the following precautions on refrigerant piping into account:

- Avoid anything but the designated refrigerant to get mixed into the refrigerant cycle (e.g. air).
- Only use R410A when adding refrigerant.
- Only use installation tools (e.g. manifold gauge set) that are exclusively used for R410A installations to withstand the pressure and to prevent foreign materials (e.g. mineral oils and moisture) from mixing into the system.
- Install the piping so that the flare is NOT subjected to mechanical stress
- Protect the piping as described in the following table to prevent dirt, liquid or dust from entering the piping.
- Use caution when passing copper tubes through walls (see figure below).

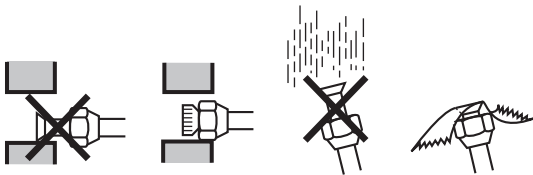

Unit	Installation period	Protection method
Outdoor unit	>1 month	Pinch the pipe
	<1 month	Pinch or tape the pipe
Indoor unit	Regardless of the period	



INFORMATION

Do NOT open the refrigerant stop valve before checking the refrigerant piping. When you need to charge additional refrigerant it is recommended to open the refrigerant stop valve after charging.

7.5.3 Guidelines when connecting the refrigerant piping

Take the following guidelines into account when connecting pipes:

- Coat the flare inner surface with ether oil or ester oil when connecting a flare nut. Tighten 3 or 4 turns by hand, before tightening firmly.

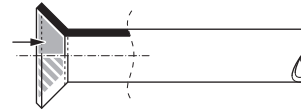

- Always use two wrenches together when loosening a flare nut.
- Always use a spanner and torque wrench together to tighten the flare nut when connecting the piping. This to prevent nut cracking and leaks.

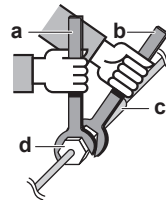

- a Torque wrench
- b Spanner
- c Piping union
- d Flare nut

Piping size (mm)	Tightening torque (N·m)	Flare dimensions (A) (mm)	Flare shape (mm)
Ø9.5	33~39	12.8~13.2	
Ø15.9	63~75	19.3~19.7	

7.5.4 Pipe bending guidelines

Use a pipe bender for bending. All pipe bends should be as gentle as possible (bending radius should be 30~40 mm or larger).

7.5.5 To flare the pipe end



CAUTION

- Incomplete flaring may cause refrigerant gas leakage.
- Do NOT re-use flares. Use new flares to prevent refrigerant gas leakage.
- Use flare nuts that are included with the unit. Using different flare nuts may cause refrigerant gas leakage.

- 1 Cut the pipe end with a pipe cutter.
- 2 Remove burrs with the cut surface facing downward so that the chips do not enter the pipe.

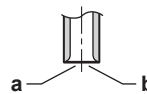

- a Cut exactly at right angles.
- b Remove burrs.

- 3 Remove the flare nut from the stop valve and put the flare nut on the pipe.
- 4 Flare the pipe. Set exactly at the position as shown in the following illustration.

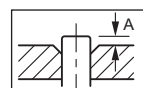

7 Installation

	Flare tool for R410A (clutch type)	Conventional flare tool	
		Clutch type (Ridgid-type)	Wing nut type (Imperial-type)
A	0~0.5 mm	1.0~1.5 mm	1.5~2.0 mm

5 Check that the flaring is properly made.

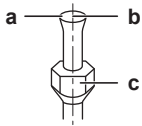

- a Flare's inner surface must be flawless.
- b The pipe end must be evenly flared in a perfect circle.
- c Make sure the flare nut is lifted.

7.5.6 To braze the pipe end

The indoor unit and outdoor unit have flare connections. Connect both ends without brazing. If brazing should be needed, take the following into account:

- When brazing, blow through with nitrogen to prevent creation of large quantities of oxidised film on the inside of the piping. This film adversely affects valves and compressors in the refrigerating system and prevents proper operation.
- Set the nitrogen pressure to 20 kPa (just enough so it can be felt on the skin) with a pressure-reducing valve.

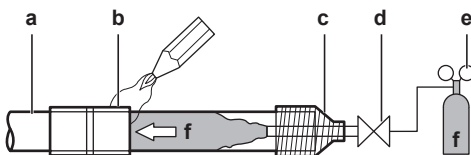

- a Refrigerant piping
- b Part to be brazed
- c Taping
- d Manual valve
- e Pressure-reducing valve
- f Nitrogen

- Do NOT use anti-oxidants when brazing pipe joints. Residue can clog pipes and break equipment.
- Do NOT use flux when brazing copper-to-copper refrigerant piping. Use phosphor copper brazing filler alloy (BCuP), which does not require flux. Flux has an extremely harmful influence on refrigerant piping systems. For instance, if chlorine based flux is used, it will cause pipe corrosion or, in particular, if the flux contains fluorine, it will deteriorate the refrigerant oil.

7.5.7 Using the stop valve and service port

To handle the stop valve

Take the following guidelines into account:

- The stop valves are factory closed.
- The following illustration shows each part required in handling the valve.

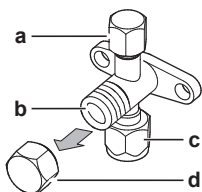

- a Service port and service port cap
- b Valve stem
- c Field piping connection
- d Stem cap

- Keep both stop valves open during operation.

- Do NOT apply excessive force to the valve stem. Doing so may break the valve body.
- Always make sure to secure the stop valve with a spanner, then loosen or tighten the flare nut with a torque wrench. Do NOT place the spanner on the stem cap, as this could cause a refrigerant leak.

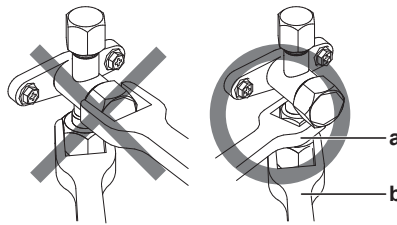

- a Spanner
- b Torque wrench

- When it is expected that the operating pressure will be low (e.g. when cooling will be performed while the outside air temperature is low), sufficiently seal the flare nut in the stop valve on the gas line with silicon sealant to prevent freezing.

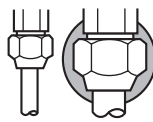

■ Silicon sealant, make sure there is no gap.

To open/close the stop valve

- 1 Remove the valve cover.
- 2 Insert a hexagon wrench (liquid side: 4 mm, gas side: 6 mm) into the valve stem and turn the valve stem:

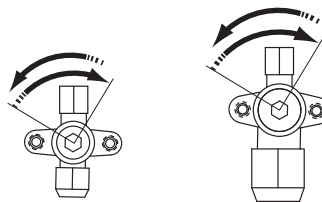

Counterclockwise to open.
Clockwise to close.

- 3 When the valve stem cannot be turned any further, stop turning. The valve is now opened/closed.

To handle the stem cap

Take the following guidelines into account:

- The stem cap is sealed where indicated with the arrow. Do NOT damage it.

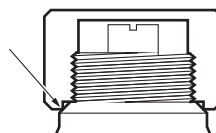

- After handling the stop valve, make sure to tighten the stem cap securely.
- For the tightening torque, refer to the following table.
- Check for refrigerant leaks after tightening the stem cap.

Item	Tightening torque (N·m)
Stem cap, liquid side	13.5~16.5
Stem cap, gas side	22.5~27.5
Service port cap	11.5~13.9

To handle the service cap

Take the following guidelines into account:

- Always use a charge hose equipped with a valve depressor pin, since the service port is a Schrader type valve.
- After handling the service port, tighten the service port cap securely. For the tightening torque, refer to the table in chapter "To handle the stem cap" on page 26.
- Check for refrigerant leaks after tightening the service port cap.

7.5.8 To connect the refrigerant piping to the outdoor unit

1 Do the following:

- Remove the service cover (a) with screw (b).
- Remove the piping intake plate (c) with screw (d).

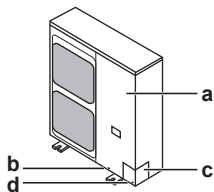

2 Choose a piping route (a, b, c or d).

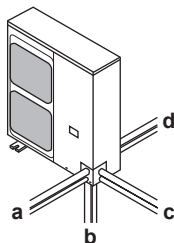

3 If you have chosen the downwards piping route:

- Drill (a, 4×) and remove the knockout hole (b).
- Cut out the slits (c) with a metal saw.

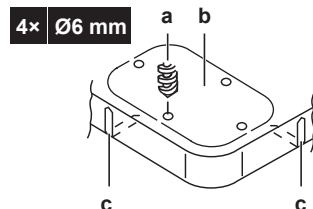

4 Do the following:

- Connect the liquid pipe (a) to the liquid stop valve.
- Connect the gas pipe (b) to the gas stop valve.

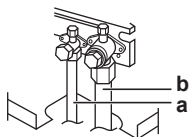

5 Do the following:

- Insulate the liquid piping (a) and the gas piping (b).
- Make sure the piping and piping insulation do NOT touch the compressor (c), the compressor terminal cover (d), and the compressor bolts (e). If the liquid pipe insulation might touch the compressor terminal cover, adjust the height of the insulation (f=no insulation around the compressor terminal cover (d)).
- Seal the insulation ends (sealant etc.) (g).

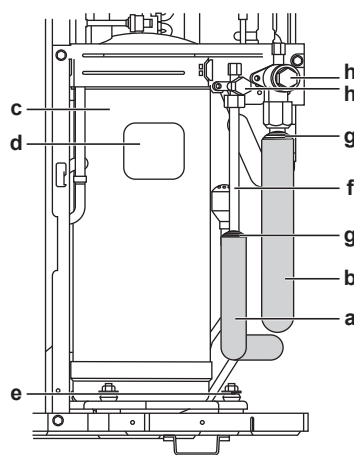

6 If the outdoor unit is installed above the indoor unit, cover the stop valves (h, see above) with sealing material to prevent condensed water on the stop valves from moving to the indoor unit.



NOTICE

Any exposed piping might cause condensation.

7 Reattach the service cover and the piping intake plate.

8 Seal all gaps (example: a) to prevent snow and small animals from entering the system.

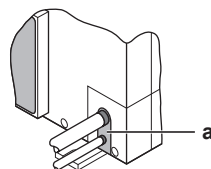

WARNING

Provide adequate measures to prevent that the unit can be used as a shelter by small animals. Small animals that make contact with electrical parts can cause malfunctions, smoke or fire.



NOTICE

Precautions when making knockout holes:

- Avoid damaging the casing.
- After making the knockout holes, we recommend you remove the burrs and paint the edges and areas around the edges using repair paint to prevent rusting.
- When passing electrical wiring through the knockout holes, wrap the wiring with protective tape to prevent damage.

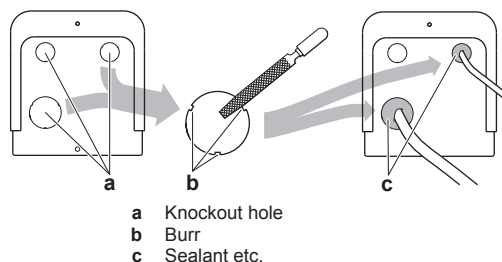

NOTICE

Make sure to open the stop valves after installing the refrigerant piping and performing vacuum drying. Running the system with the stop valves closed may break the compressor.

7 Installation

7.5.9 To connect the refrigerant piping to the indoor unit

- 1 Connect the liquid stop valve from the outdoor unit to the refrigerant liquid connection of the indoor unit.

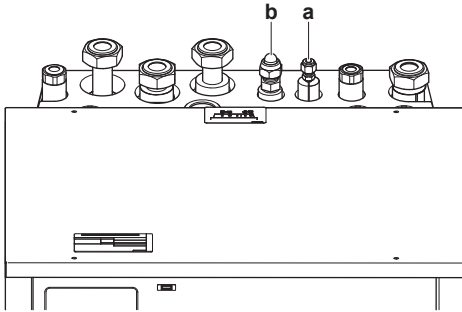

- a Refrigerant liquid connection
b Refrigerant gas connection

- 2 Connect the gas stop valve from the outdoor unit to the refrigerant gas connection of the indoor unit.

NOTICE

It is recommended that the refrigerant piping between indoor and outdoor unit is installed in a ducting or the refrigerant piping is wrapped with finishing tape.

7.5.10 To determine if oil traps are required

If oil flows back into the outdoor unit's compressor, this might cause liquid compression or deterioration of oil return. Oil traps in the rising gas piping can prevent this.

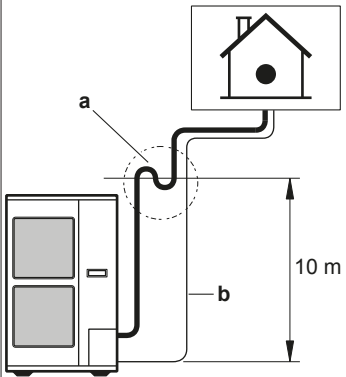
If	Then
The indoor unit is installed higher than the outdoor unit	Install an oil trap every 10 m (height difference). 
The outdoor unit is installed higher than the indoor unit	Oil traps are NOT required.

7.6 Checking the refrigerant piping

7.6.1 About checking the refrigerant piping

The outdoor unit's **internal** refrigerant piping has been factory tested for leaks. You only have to check the outdoor unit's **external** refrigerant piping.

Before checking the refrigerant piping

Make sure the refrigerant piping is connected between the outdoor unit and the indoor unit.

Typical workflow

Checking the refrigerant piping typically consists of the following stages:

- 1 Checking for leaks in the refrigerant piping.
- 2 Performing vacuum drying to remove all moisture, air or nitrogen from the refrigerant piping.

If there is a possibility of moisture being present in the refrigerant piping (for example, water may have entered the piping), first carry out the vacuum drying procedure below until all moisture has been removed.

7.6.2 Precautions when checking the refrigerant piping

INFORMATION

Also read the precautions and requirements in the following chapters:

- General safety precautions
- Preparation

NOTICE

Use a 2-stage vacuum pump with a non-return valve that can evacuate to a gauge pressure of -100.7 kPa (5 Torr absolute). Make sure the pump oil does not flow oppositely into the system while the pump is not working.

NOTICE

Use this vacuum pump for R410A exclusively. Using the same pump for other refrigerants may damage the pump and the unit.

NOTICE

- Connect the vacuum pump to **both** the service port of the gas stop valve and the service port of the liquid stop valve to increase efficiency.
- Make sure that the gas stop valve and liquid stop valve are firmly closed before performing the leak test or vacuum drying.

7.6.3 Checking refrigerant piping: Setup

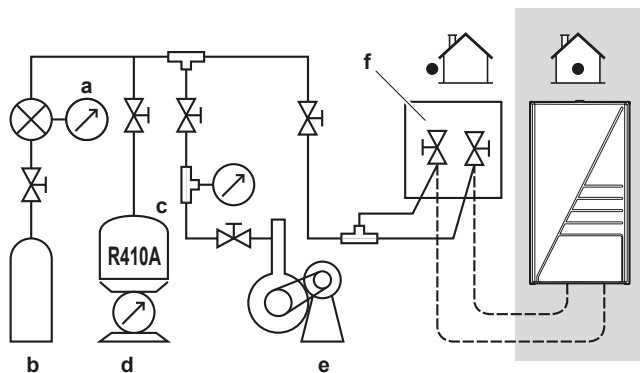

- a Pressure gauge
b Nitrogen
c Refrigerant
d Weighing machine
e Vacuum pump
f Stop valve

7.6.4 To check for leaks

NOTICE

Do NOT exceed the unit's maximum working pressure (see "PS High" on the unit name plate).

**NOTICE**

Make sure to use a recommended bubble test solution from your wholesaler. Do not use soap water, which may cause cracking of flare nuts (soap water may contain salt, which absorbs moisture that will freeze when the piping gets cold), and/or lead to corrosion of flared joints (soap water may contain ammonia which causes a corrosive effect between the brass flare nut and the copper flare).

- 1 Charge the system with nitrogen gas up to a gauge pressure of at least 200 kPa (2 bar). It is recommended to pressurize to 3000 kPa (30 bar) in order to detect small leaks.
- 2 Check for leaks by applying the bubble test solution to all connections.
- 3 Discharge all nitrogen gas.

**INFORMATION**

After opening the stop valve, it is possible that the pressure in the refrigerant piping does NOT increase. This might be caused by e.g. the closed state of the expansion valve in the outdoor unit circuit, but does NOT present any problem for correct operation of the unit.

7.6.5 To perform vacuum drying

- 1 Vacuum the system until the pressure on the manifold indicates -0.1 MPa (-1 bar).
- 2 Leave as is for 4-5 minutes and check the pressure:

If the pressure...	Then...
Does not change	There is no moisture in the system. This procedure is finished.
Increases	There is moisture in the system. Go to the next step.

- 3 Evacuate for at least 2 hours to a pressure on the manifold of -0.1 MPa (-1 bar).
- 4 After turning OFF the pump, check the pressure for at least 1 hour.
- 5 If you do NOT reach the target vacuum or cannot maintain the vacuum for 1 hour, do the following:
 - Check for leaks again.
 - Perform vacuum drying again.

**NOTICE**

Make sure to open the stop valves after installing the refrigerant piping and performing vacuum drying. Running the system with the stop valves closed may break the compressor.

7.7 Charging refrigerant**7.7.1 About charging refrigerant**

The outdoor unit is factory charged with refrigerant, but in some cases the following might be necessary:

What	When
Charging additional refrigerant	When the total liquid piping length is more than specified (see later).
Completely recharging refrigerant	Example: <ul style="list-style-type: none"> ▪ When relocating the system. ▪ After a leak.

Charging additional refrigerant

Before charging additional refrigerant, make sure the outdoor unit's **external** refrigerant piping is checked (leak test, vacuum drying).

**INFORMATION**

Depending on the units and/or the installation conditions, it might be necessary to connect electrical wiring before you can charge refrigerant.

Typical workflow – Charging additional refrigerant typically consists of the following stages:

- 1 Determining if and how much you have to charge additionally.
- 2 If necessary, charging additional refrigerant.
- 3 Filling in the fluorinated greenhouse gases label, and fixing it to the inside of the outdoor unit.

Completely recharging refrigerant

Before completely recharging refrigerant, make sure the following is done:

- 1 The system is pumped down.
- 2 The outdoor unit's **external** refrigerant piping is checked (leak test, vacuum drying).
- 3 Vacuum drying on the outdoor unit's **internal** refrigerant piping is performed.

**NOTICE**

Before completely recharging, perform vacuum drying on the outdoor unit's **internal** refrigerant piping as well. To do so, use the internal service port of the outdoor unit (between the heat exchanger and the 4-way valve). Do NOT use the service ports of the stop valves, because vacuum drying cannot be performed properly from these ports.

Typical workflow – Completely recharging refrigerant typically consists of the following stages:

- 1 Determining how much refrigerant to charge.
- 2 Charging refrigerant.
- 3 Filling in the fluorinated greenhouse gases label, and fixing it to the inside of the outdoor unit.

7.7.2 Precautions when charging refrigerant**INFORMATION**

Also read the precautions and requirements in the following chapters:

- General safety precautions
- Preparation

7.7.3 To determine the additional refrigerant amount

If the total liquid piping length is...	Then...
≤10 m	Do NOT add additional refrigerant.
>10 m	$R = (\text{total length (m) of liquid piping} - 10 \text{ m}) \times 0.054$ $R = \text{Additional charge (kg)} (\text{rounded in units of } 0.1 \text{ kg})$

**INFORMATION**

Piping length is the one way length of liquid piping.

7 Installation

7.7.4 To determine the complete recharge amount



INFORMATION

If a complete recharge is necessary, the total refrigerant charge is: the factory refrigerant charge (see unit name plate) + the determined additional amount.

7.7.5 To charge refrigerant



WARNING

- Only use R410A as refrigerant. Other substances may cause explosions and accidents.
- R410A contains fluorinated greenhouse gases. Its global warming potential value is 2087.5. Do NOT vent these gases into the atmosphere.
- When charging refrigerant, always use protective gloves and safety glasses.



CAUTION

To avoid compressor breakdown, do NOT charge more than the specified amount of refrigerant.

Prerequisite: Before charging refrigerant, make sure the refrigerant piping is connected and checked (leak test and vacuum drying).

- 1 Connect the refrigerant cylinder to both the service port of the gas stop valve and the service port of the liquid stop valve.
- 2 Charge the additional refrigerant amount.
- 3 Open the stop valves.

If pump down is needed in case of dismantling or relocating the system, see "13.3 To pump down" on page 70 for more details.

7.7.6 To fix the fluorinated greenhouse gases label



NOTICE

National implementation of EU regulation on certain fluorinated greenhouse gases may require to provide the appropriate official language on the unit. Therefore, an additional multilingual fluorinated greenhouse gases label is supplied with the unit.

- 1 Fill in the label as follows:

Contains fluorinated greenhouse gases

① = kg

② = kg

①+② = kg

- a From the multilingual fluorinated greenhouse gases label peel off the applicable language and stick it on top of a.
- b Factory refrigerant charge: see unit name plate
- c Additional refrigerant amount charged
- d Total refrigerant charge

- 2 Fix the label on the inside of the outdoor unit near the gas and liquid stop valves.

7.8 Connecting the water piping

7.8.1 About connecting the water piping

Before connecting the water piping

Make sure the outdoor and indoor unit are mounted.

Typical workflow

Connecting the water piping typically consists of the following stages:

- 1 Connecting the water piping of the indoor unit.
- 2 Connecting the pressure relief valve to the drain.
- 3 Filling the water circuit.
- 4 Filling the domestic hot water tank.
- 5 Insulating the water piping.
- 6 Connecting the recirculation piping.

7.8.2 Precautions when connecting the water piping



INFORMATION

Also read the precautions and requirements in the following chapters:

- General safety precautions
- Preparation

7.8.3 To connect the water piping



NOTICE

Do NOT use excessive force when connecting the piping. Deformation of the piping can cause malfunctioning of the unit.

To facilitate service and maintenance, 4 shut-off valves are provided. Mount the valves on the water inlets and on the water outlets. Mind their position. Orientation of the integrated drain and fill valves is important for servicing.



NOTICE

This unit is designed for operation on 2 temperature zones:

- underfloor heating in the **main zone** (water temperature 35°C), this is the zone with the **lowest water temperature**,
- radiators in the **additional zone** (water temperature 45°C), this is the zone with the **highest water temperature**.

- 1 Install the shut-off valves on the water pipes.

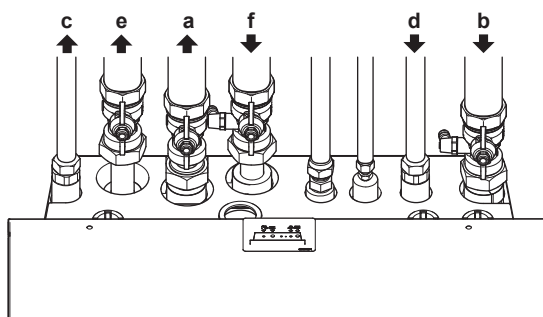

- a Space heating additional zone water out
- b Space heating additional zone water in
- c Domestic hot water out
- d Domestic cold water in (cold water supply)
- e Space heating main zone water out
- f Space heating main zone water in



NOTICE

It is recommended to install shut-off valves to domestic cold water in and domestic hot water out connections. Shut-off valves are field supplied.

! NOTICE

To avoid damage to the surroundings in case of water leakage, it is recommended to close the cold water inlet shut-off valves during periods of absence.

- 2 Screw the indoor unit nuts on the shut-off valves.
- 3 Connect the domestic hot water in and out pipes to the indoor unit.

! NOTICE

- A drain device and pressure relief device should be installed on the cold water inlet connection of the domestic hot water cylinder.
- To avoid back siphonage, it is recommended to install a non-return valve on the water inlet of the domestic hot water tank in accordance with the applicable legislation.
- It is recommended to install a pressure reducing valve on the cold water inlet in accordance with the applicable legislation.
- An expansion vessel should be installed on the cold water inlet in accordance with the applicable legislation.
- It is recommended to install the pressure relief valve on a higher position than the top of the domestic hot water tank. Heating of the domestic hot water tank causes water to expand and without pressure relief valve the water pressure inside the tank can rise above the tank design pressure. Also the field installation (piping, tapping points, etc.) connected to the tank is subjected to this high pressure. To prevent this, a pressure relieve valve needs to be installed. The overpressure prevention depends on the correct operation of the field installed pressure relief valve. If this is NOT working correctly, overpressure will deform the tank and water leakage may occur. To confirm good operation, regular maintenance is required.

7.8.4 To connect the recirculation piping

Prerequisite: Only required if you need recirculation in your system.

- 1 Loosen and remove the 4 screws that fix the top panel.
- 2 Remove the top panel from the unit.

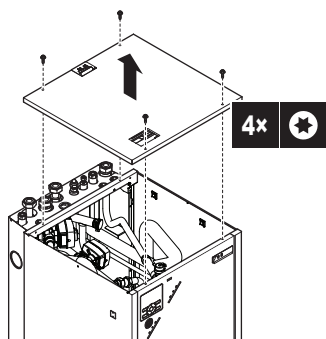

- 3 Connect the recirculation piping to the recirculation connection (b) and route the piping through the hole at the backside of the unit (a).

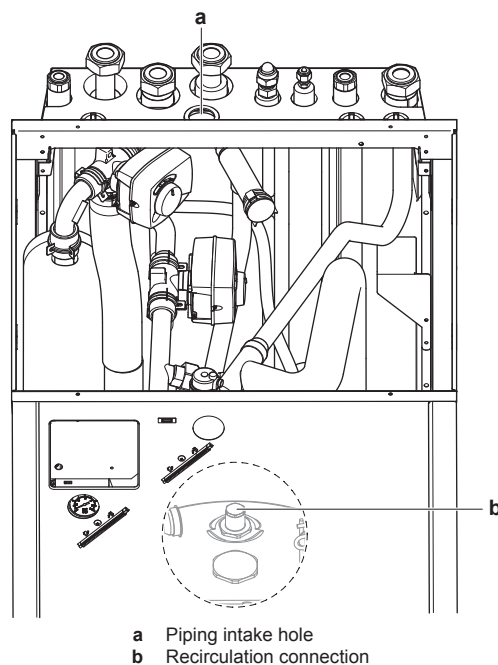

- 4 Re-attach the casing.

7.8.5 To connect the pressure relief valve to the drain

The blow out of the pressure relief valve is coming out of the backside of the unit.

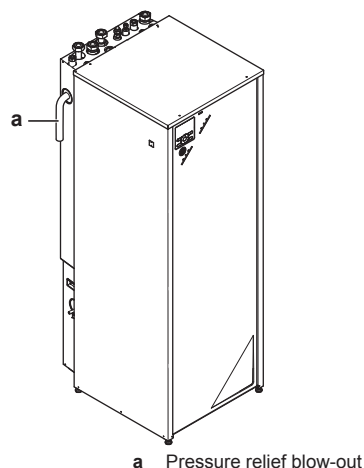

The blow out should be connected to an appropriate drain according to the applicable legislation. It is recommended to use a tundish.

7.8.6 To fill the water circuit

- 1 Connect the water supply hose to the fill valve.

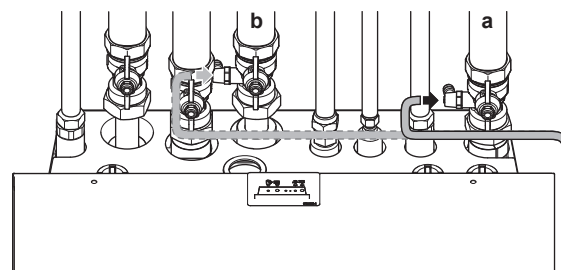
**i INFORMATION**

Please fill with water through connection a OR b. Both circuits (main and additional) will be filled.

7 Installation

- 2 Open the fill valve.
- 3 Make sure that the automatic air purge valve is open (at least 2 turns).



INFORMATION

For location of the air purge valve, see "Components: Indoor unit" in chapter "14 Technical data" on page 71.

- 4 Fill the circuit with water until the manometer indicates a pressure of ± 2.0 bar.
- 5 Purge as much air as possible from the water circuit.
- 6 Close the fill valve.
- 7 Disconnect the water supply hose from the fill valve.



NOTICE

The water pressure indicated on the manometer will vary depending on the water temperature (higher pressure at higher water temperature).

However, at all times water pressure shall remain above 1 bar to avoid air entering the circuit.

7.8.7 To fill the domestic hot water tank

- 1 Open every hot water tap in turn to purge air from the system pipe work.
- 2 Open the cold water supply valve.
- 3 Close all water taps after all air is purged.
- 4 Check for water leaks.
- 5 Manually operate the field-installed pressure relief valve to ensure a free water flow through the discharge pipe.

7.8.8 To insulate the water piping

The piping in the complete water circuit MUST be insulated to prevent condensation during defrost operation and reduction of the heating capacity.

If the temperature is higher than 30°C and the humidity is higher than RH 80%, the thickness of the insulation materials should be at least 20 mm to prevent condensation on the surface of the insulation.

7.9 Connecting the electrical wiring

7.9.1 About connecting the electrical wiring

Before connecting the electrical wiring

Make sure:

- The refrigerant piping is connected and checked
- The water piping is connected

Typical workflow

Connecting the electrical wiring typically consists of the following stages:

- 1 Making sure the power supply system complies with the electrical specifications of the heat pump.
- 2 Connecting the electrical wiring to the outdoor unit.
- 3 Repositioning the air thermistor on the outdoor unit.
- 4 Connecting the electrical wiring to the indoor unit.
- 5 Connecting the main power supply.
- 6 Connecting the backup heater power supply.
- 7 Connecting the user interface.
- 8 Connecting the shut-off valves.
- 9 Connecting the electrical meters.
- 10 Connecting the domestic hot water pump.
- 11 Connecting the alarm output.
- 12 Connecting the changeover to an external heat source.
- 13 Connecting the power consumption digital inputs.

7.9.2 About electrical compliance

ERHQ_V3

Equipment complying with EN/IEC 61000-3-12 (European/International Technical Standard setting the limits for harmonic currents produced by equipment connected to public low-voltage systems with input current > 16 A and ≤ 75 A per phase.).

ERLQ_V3

Equipment complying with:

- **EN/IEC 61000-3-11** provided that the system impedance Z_{sys} is less than or equal to Z_{max} at the interface point between the user's supply and the public system.
 - EN/IEC 61000-3-11 = European/International Technical Standard setting the limits for voltage changes, voltage fluctuations and flicker in public low-voltage supply systems for equipment with rated current ≤ 75 A.
 - It is the responsibility of the installer or user of the equipment to ensure, by consultation with the distribution network operator if necessary, that the equipment is connected only to a supply with a system impedance Z_{sys} less than or equal to Z_{max} .
- **EN/IEC 61000-3-12** provided that the short-circuit power S_{sc} is greater than or equal to the minimum S_{sc} value at the interface point between the user's supply and the public system.
 - EN/IEC 61000-3-12 = European/International Technical Standard setting the limits for harmonic currents produced by equipment connected to public low-voltage systems with input current > 16 A and ≤ 75 A per phase.
 - It is the responsibility of the installer or user of the equipment to ensure, by consultation with the distribution network operator if necessary, that the equipment is connected only to a supply with a short-circuit power S_{sc} greater than or equal to the minimum S_{sc} value.

Model	Z_{max}	Minimum S_{sc} value
ERLQ011CAV3	0.22 Ω	525 kVA
ERLQ014CAV3		
ERLQ016CAV3		

ERLQ_W1

Equipment complying with EN/IEC 61000-3-12 (European/International Technical Standard setting the limits for harmonic currents produced by equipment connected to public low-voltage systems with input current > 16 A and ≤ 75 A per phase.).

Only for indoor units

See "7.9.10 To connect the backup heater power supply" on page 36.

7.9.3 Precautions when connecting the electrical wiring

i INFORMATION

Also read the precautions and requirements in the following chapters:

- General safety precautions
- Preparation

⚡ DANGER: RISK OF ELECTROCUTION

i INFORMATION

More information about the legend and the location of the wiring diagram of the unit can be found in "14.6 Wiring diagram" on page 84.

⚠ WARNING

ALWAYS use multicore cable for power supply cables.

7.9.4 Guidelines when connecting the electrical wiring

Keep the following in mind:

- If stranded conductor wires are being used, install a round crimp-style terminal on the tip. Place the round crimp-style terminal on the wire up to the covered part and fasten the terminal with the appropriate tool.

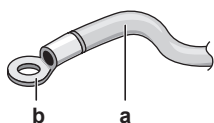

a Stranded conductor wire
b Round crimp-style terminal

- Use the following methods for installing wires:

Wire type	Installation method
Single core wire	<p>a Curled single core wire b Screw c Flat washer</p>
Stranded conductor wire with round crimp-style terminal	<p>a Terminal b Screw c Flat washer</p>

! NOTICE

Precautions when laying power wiring:

- Do not connect wiring of different thicknesses to the power terminal block (slack in the power wiring may cause abnormal heat).
- When connecting wiring which is the same thickness, do as shown in the figure below.



- For wiring, use the designated power wire and connect firmly, then secure to prevent outside pressure being exerted on the terminal board.
- Use an appropriate screwdriver for tightening the terminal screws. A screwdriver with a small head will damage the head and make proper tightening impossible.
- Over-tightening the terminal screws may break them.

Tightening torques

Item	Tightening torque (N·m)
M4 (X1M)	1.2~1.8
M5 (X1M)	2.0~3.0
M5 (earth)	3.0~4.0

7.9.5 Specifications of standard wiring components

Component	V3		W1		
	ERHQ	ERLQ	ERHQ	ERLQ	
Power supply cable	MCA ^(a)	31.9 A	34.2 A	13.5 A	16.3 A
	Voltage	230 V		400 V	
	Phase	1~		3N~	
	Frequency	50 Hz			
	Wire sizes	Must comply with applicable legislation			
Interconnection cable	Minimum cable section of 2.5 mm ² and applicable for 230 V				
Recommended field fuse	32 A	40 A	20 A		
Earth leakage circuit breaker	Must comply with applicable legislation				

(a) MCA=Minimum circuit ampacity. Stated values are maximum values (see electrical data of combination with indoor units for exact values).

7.9.6 To connect the electrical wiring on the outdoor unit

! NOTICE

- Follow the wiring diagram (delivered with the unit, located at the inside of the service cover).
- Make sure the electrical wiring does NOT obstruct proper reattachment of the service cover.

1 Remove the service cover. See "7.2.2 To open the outdoor unit" on page 22.

2 Strip insulation (20 mm) from the wires.



7 Installation

- a Strip wire end to this point
- b Excessive strip length may cause electrical shock or leakage.

3 Connect the interconnection cable and power supply as follows:

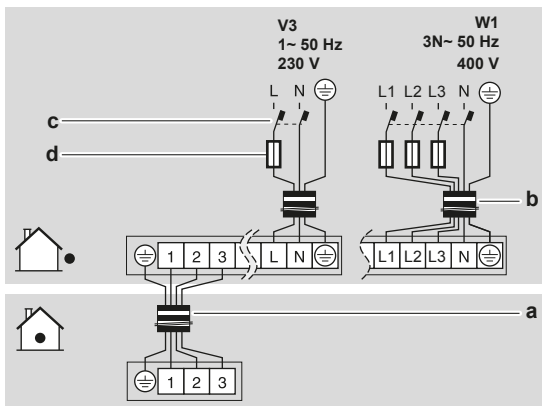

- a Interconnection cable
- b Power supply cable
- c Earth leakage circuit breaker
- d Fuse

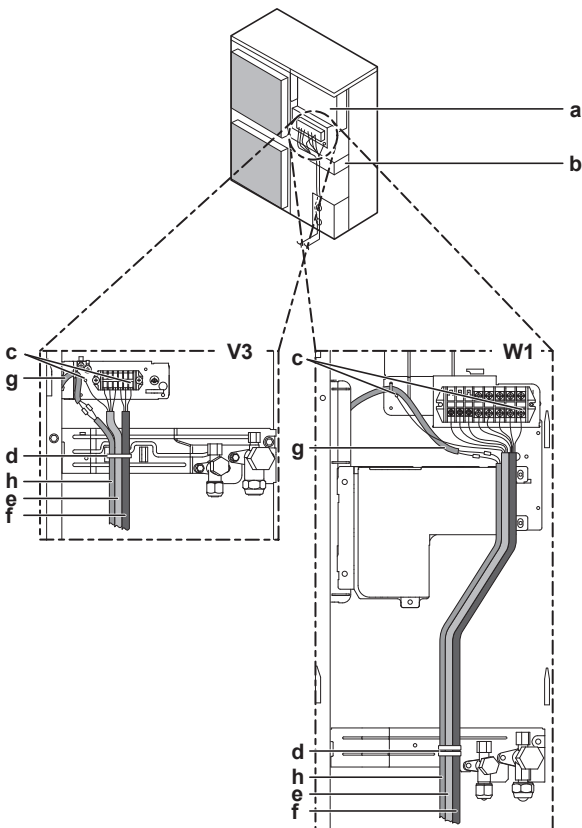

- a Switch box
- b Stop valve attachment plate
- c Earth
- d Cable tie
- e Interconnection cable
- f Power supply cable

Only if bottom plate heater is installed (option for ERHQ):

- g Bottom plate heater cable
- h Power supply cable of the bottom plate heater (from the indoor unit)



INFORMATION

ERLQ units control the bottom plate heater internally (field wiring NOT required).

- 4 Fix the cables (power supply, interconnection cable and power supply of the bottom plate heater (if applicable)) with a cable tie to the stop valve attachment plate.
- 5 Route the wiring through the frame and connect it to it.

Routing through the frame

Choose one of the 3 possibilities:

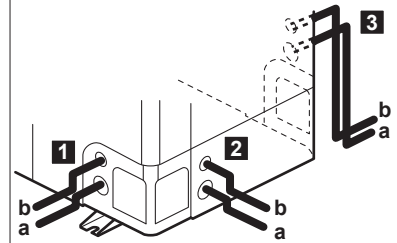

a Power supply, earth wiring, and bottom plate heater wire (if applicable)

b Interconnection cable

Connecting to the frame

When cables are routed from the unit, a protection sleeve for the conduits (PG insertions) can be inserted at the knockout hole.

When you do not use a wire conduit, protect the wires with vinyl tubes to prevent the edge of the knockout hole from cutting the wires.

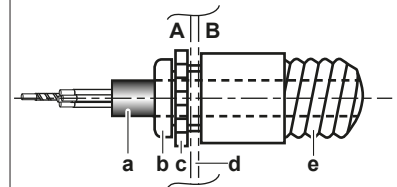

A Inside of the outdoor unit

B Outside of the outdoor unit

- a Wire
- b Bush
- c Nut
- d Frame
- e Hose

6 Reattach the service cover. See "7.10.2 To close the outdoor unit" on page 39.

7 Connect an earth leakage circuit breaker and fuse to the power supply line.

7.9.7 To reposition the air thermistor on the outdoor unit

This task is only required for ERLQ.

Required accessories:

	Thermistor fixture. Use the one from the accessory bag.
	Thermistor fixing plate. Reuse the one attached to the unit. If necessary, you can use the spare one from the accessory bag.

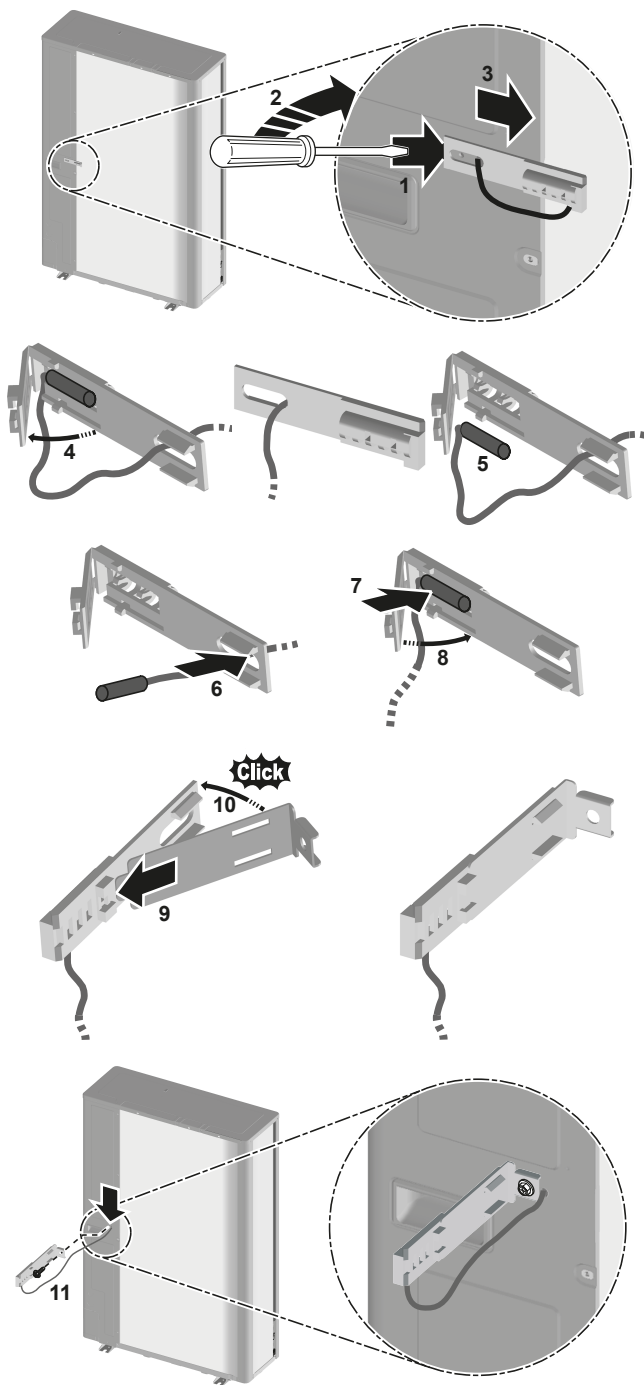

7.9.8 To connect the electrical wiring on the indoor unit

- 1 To open the indoor unit, see "7.2.3 To open the indoor unit" on page 22 and "7.2.4 To open the switch box cover of the indoor unit" on page 22.
- 2 Wiring should enter the unit from the top:

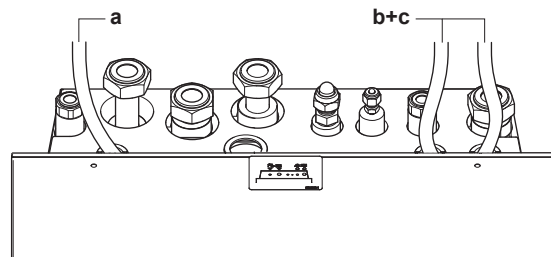

- 3 Routing of the wiring inside the unit should be as follows:

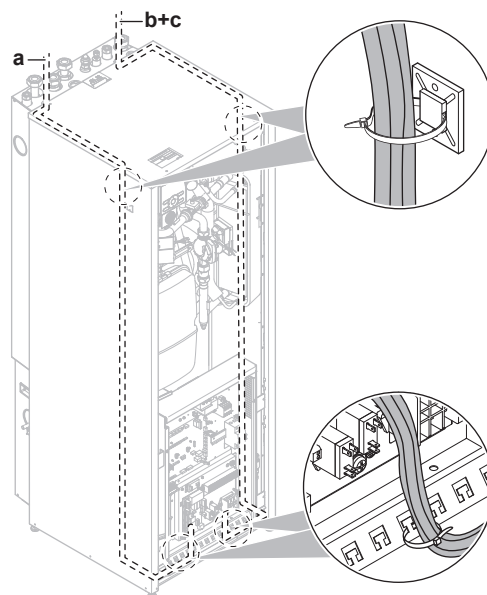

- 4 Fix the cable with cable ties to the cable tie mountings to ensure strain relief and to make sure that it does NOT come in contact with the piping and sharp edges.



INFORMATION

To access the domestic hot water temperature sensor, the switch box can be tilted. The switch box should NOT be removed from the unit.

Routing	Possible cables (depending on unit type and installed options)
a Low voltage	<ul style="list-style-type: none"> ▪ Preferential power supply contact ▪ User interface ▪ Power consumption digital inputs (field supply) ▪ Outdoor ambient temperature sensor (option) ▪ Indoor ambient temperature sensor (option) ▪ Electrical meters (field supply) ▪ Safety thermostat (field supply)
b High voltage power supply	<ul style="list-style-type: none"> ▪ Interconnection cable ▪ Normal kWh rate power supply ▪ Preferential kWh rate power supply ▪ Power supply for backup heater ▪ Power supply for bottom plate heater (option)

7 Installation

Routing	Possible cables (depending on unit type and installed options)
c	<ul style="list-style-type: none"> Heat pump convector (option)
High voltage control signal	<ul style="list-style-type: none"> Room thermostat (option) Shut-off valve (field supply) Domestic hot water pump (field supply) Alarm output Changeover to external heat source control Space heat operation control



CAUTION

Do NOT push or place redundant cable length in the unit.

7.9.9 To connect the main power supply

- 1 Connect the main power supply.

In case of normal kWh rate power supply

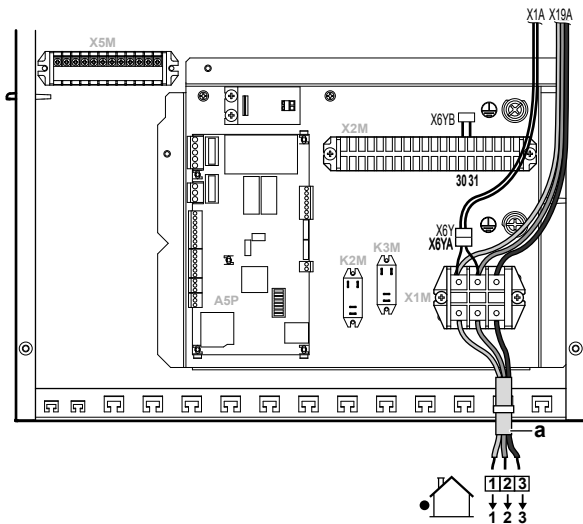

Legend: see illustration below.

In case of preferential kWh rate power supply

Connect X6Y to X6YB.

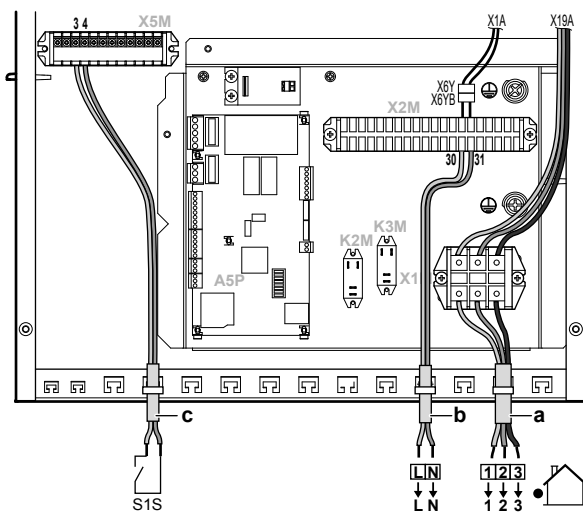

- Interconnection cable (=main power supply)
- Normal kWh rate power supply
- Preferential power supply contact

- 2 Fix the cable with cable ties to the cable tie mountings.



INFORMATION

In case of preferential kWh rate power supply, connect X6Y to X6YB. The necessity of separate normal kWh rate power supply to indoor unit (b) X2M30/31 depends on the type of preferential kWh rate power supply.

Separate connection to the indoor unit is required:

- if preferential kWh rate power supply is interrupted when active, OR
- if no power consumption of the indoor unit is allowed at the preferential kWh rate power supply when active.

7.9.10 To connect the backup heater power supply



CAUTION

To guarantee the unit is completely earthed, always connect the backup heater power supply and the earth cable.

Make sure that the power supply is in accordance with the backup heater capacity, as listed in the table below.

Backup heater type	Backup heater capacity	Power supply	Maximum running current	Z _{max} (Ω)
*3V	3 kW	1~ 230 V	13 A	—

- 1 Connect the backup heater power supply. A double-pole fuse is used for F1B.

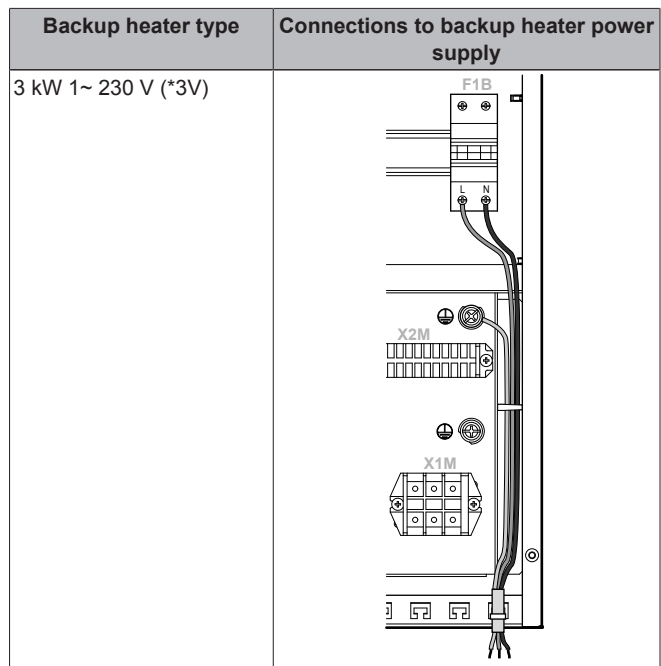

- 2 Fix the cable with cable ties to the cable tie mountings.

7.9.11 To connect the user interface

- If you use 1 user interface, you can install it at the indoor unit (for control close to the indoor unit), or in the room (when used as room thermostat).
- If you use 2 user interfaces, you can install 1 user interface at the indoor unit (for control close to the indoor unit) + 1 user interface in the room (used as room thermostat).

i INFORMATION

The user interface can only be used as room thermostat of the **main zone**.

The procedure differs slightly depending on where you install the user interface.

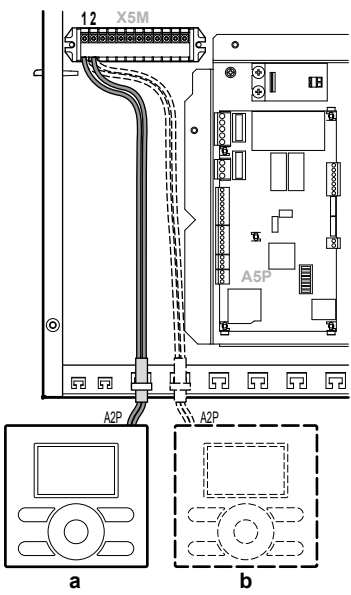
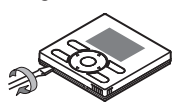
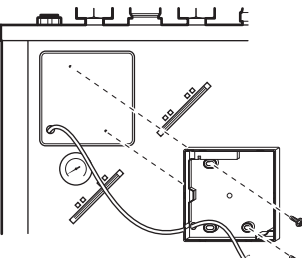
#	At the indoor unit	In the room
1	<p>Connect the user interface cable to the indoor unit. Fix the cable with cable ties to the cable tie mountings.</p>  <p>a Main user interface^(a) b Optional user interface</p>	
2	<p>Insert a screwdriver into the slots underneath the user interface and carefully separate the faceplate from the wallplate. The PCB is mounted in the faceplate of the user interface. Be careful NOT to damage it.</p> 	
3	<p>Fix the wallplate of the user interface to the sheet metal of the unit. Be careful NOT to distort the shape of the backside of the user interface by overtightening the mounting screws.</p> 	<p>Fix the wallplate of the user interface to the wall.</p>

#	At the indoor unit	In the room
4	Connect as shown in 4A.	Connect as shown in 4A, 4B, 4C or 4D.
5	Reinstall the faceplate onto the wallplate. Be careful NOT to pinch the wiring when attaching the frontplate to the unit.	

(a) The main user interface is required for operation, but has to be ordered separately (mandatory option).

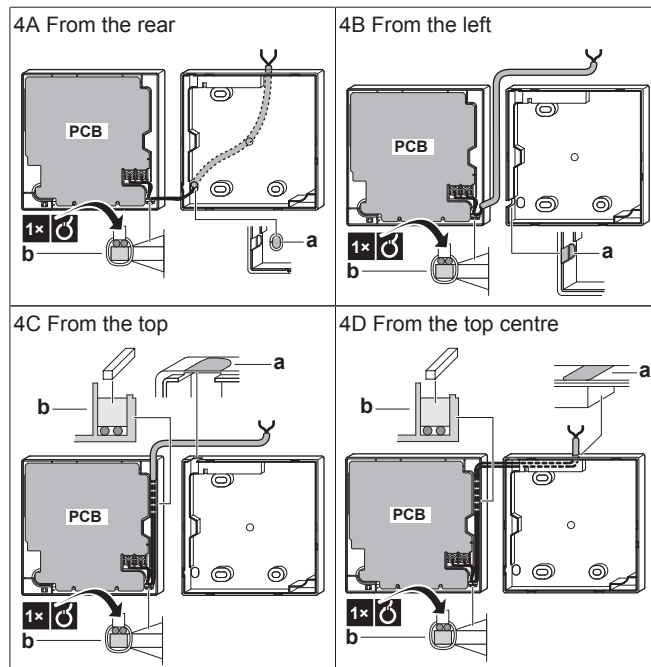

- a Notch this part for the wiring to pass through with nippers etc.
- b Secure the wiring to the front part of the casing using the wiring retainer and clamp.

7.9.12 To connect the shut-off valve

- 1 Connect the valve control cable to the appropriate terminals as shown in the illustration below.

! NOTICE

Wiring is different for a NC (normal closed) valve and a NO (normal open) valve.

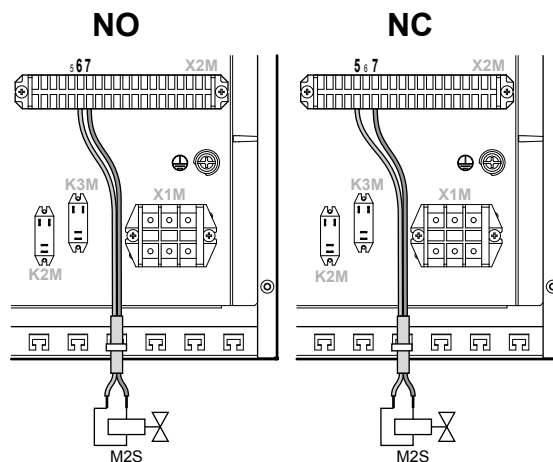

- 2 Fix the cable with cable ties to the cable tie mountings.

7 Installation

7.9.13 To connect the electrical meters



INFORMATION

In case of an electrical meter with transistor output, check the polarity. The positive polarity **MUST** be connected to X5M/7 and X5M/9; the negative polarity to X5M/8 and X5M/10.

- 1 Connect the electrical meters cable to the appropriate terminals as shown in the illustration below.

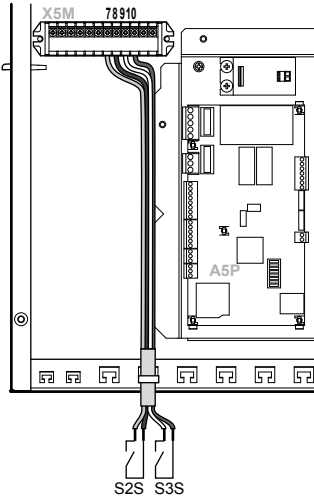

- 2 Fix the cable with cable ties to the cable tie mountings.

7.9.14 To connect the domestic hot water pump

- 1 Connect the domestic hot water pump cable to the appropriate terminals as shown in the illustration below.

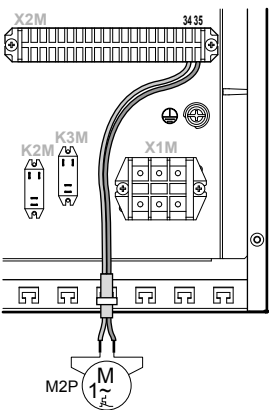

- 2 Fix the cable with cable ties to the cable tie mountings.

7.9.15 To connect the alarm output

- 1 Connect the alarm output cable to the appropriate terminals as shown in the illustration below.

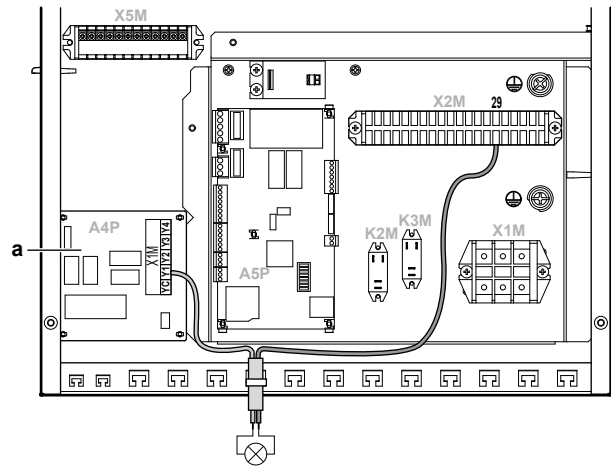

a Installation of EKRP1HB is required.

- 2 Fix the cable with cable ties to the cable tie mountings.

7.9.16 To connect the power consumption digital inputs

- 1 Connect the power consumption digital inputs cable to the appropriate terminals as shown in the illustration below.

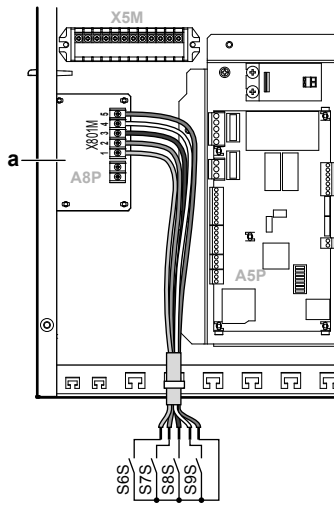

a Installation of EKRP1AHTA is required.

- 2 Fix the cable with cable ties to the cable tie mountings.

7.9.17 To connect the safety thermostat (normal closed contact)

- 1 Connect the safety thermostat (normal closed) cable to the appropriate terminals as shown in the illustration below.

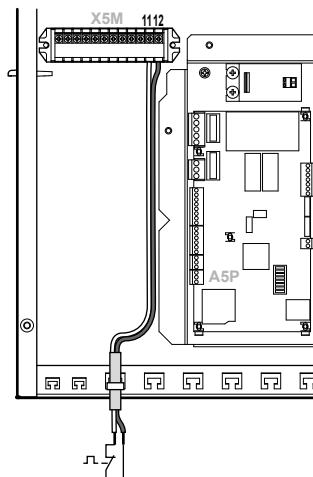

2 Fix the cable with cable ties to the cable tie mountings.



INFORMATION

Installation of a safety thermostat (field supply) is required, otherwise the unit will NOT operate.



NOTICE

A safety thermostat **MUST** be installed on the main zone to avoid too high water temperatures in this zone. The safety thermostat is typically a thermostatically controlled valve with a normal closed contact. When the water temperature in the main zone is too high, the contact will open and the user interface will show a 8H-02 error. **ONLY** the main pump will stop.

7.10 Finishing the outdoor unit installation

7.10.1 To finish the outdoor unit installation

1 Insulate and fix the refrigerant piping and interconnection cable as follows:

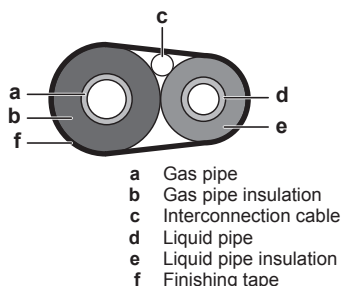

2 Install the service cover.

7.10.2 To close the outdoor unit



NOTICE

When closing the outdoor unit cover, make sure that the tightening torque does NOT exceed 4.1 N•m.

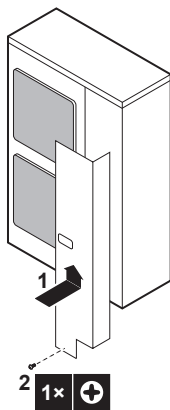

7.11 Finishing the indoor unit installation

7.11.1 To fix the user interface cover to the indoor unit

- 1 Make sure that the front panel is removed from the indoor unit. See "7.2.3 To open the indoor unit" on page 22.
- 2 Plug the user interface cover into the hinges.

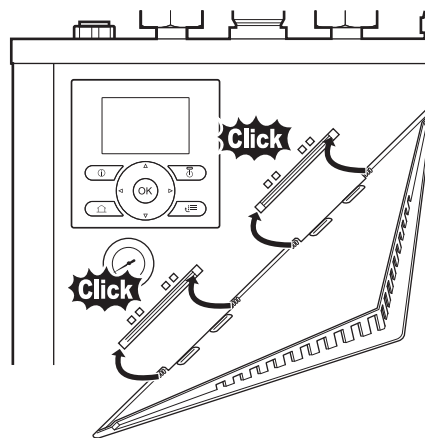

3 Mount the front panel to the indoor unit.

7.11.2 To close the indoor unit

- 1 Close the switch box cover.
- 2 Reinstall the top plate.
- 3 Reinstall the front panel.



NOTICE

When closing the indoor unit cover, make sure that the tightening torque does NOT exceed 4.1 N•m.

8 Configuration

8.1 Overview: Configuration

This chapter describes what you have to do and know to configure the system after it is installed.

Why

If you do NOT configure the system correctly, it might NOT work as expected. The configuration influences the following:

- The calculations of the software
- What you can see on and do with the user interface

How

You can configure the system using two different methods.

Method	Description
Configuring via the user interface	First time – Quick wizard. When you turn ON the user interface for the first time (via the indoor unit), a quick wizard starts to help you configure the system. Afterwards. If necessary, you can make changes to the configuration afterwards.
Configuring via the PC configurator	You can prepare the configuration off-site on PC and afterwards upload the configuration to the system with the PC configurator. See also: "8.1.1 To connect the PC cable to the switch box" on page 40.



INFORMATION

When the installer settings are changed, the user interface will request to confirm. When confirmed, the screen will shortly turn OFF and "busy" will be displayed for several seconds.

8 Configuration

Accessing settings – Legend for tables

You can access the installer settings using two different methods. However, NOT all settings are accessible via both methods. If so, the corresponding table columns in this chapter are set to N/A (not applicable).

Method	Column in tables
Accessing settings via the breadcrumb in the menu structure.	#
Accessing settings via the code in the overview settings.	Code

See also:

- "To access the installer settings" on page 40
- "8.5 Menu structure: Overview installer settings" on page 59

8.1.1 To connect the PC cable to the switch box

Prerequisite: The EKPCCAB kit is required.

- 1 Connect the cable with USB connection to your PC.
- 2 Connect the plug of the cable to X10A on A1P of the switch box of the indoor unit.

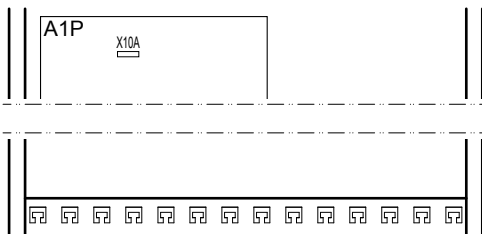

- 3 Pay special attention to the position of the plug!

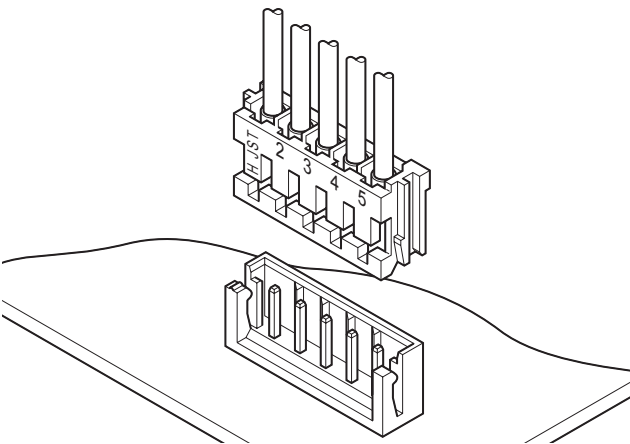

NOTICE

Another cable is already connected to X10A. To connect the PC cable to X10A, therefore temporarily disconnect this other cable. Do NOT forget to reconnect it afterwards.

8.1.2 To access the most used commands

To access the installer settings

- 1 Set the user permission level to Installer.
- 2 Go to [A]: > Installer settings.

To access the overview settings

- 1 Set the user permission level to Installer.
- 2 Go to [A.8]: > Installer settings > Overview settings.

To set the user permission level to Installer

- 1 Set the user permission level to Adv. end user.

- 2 Go to [6.4]: > Information > User permission level.
- 3 Press for more than 4 seconds.
Result: is displayed on the home pages.
- 4 If you do NOT press any button for more than 1 hour or press again for more than 4 seconds, the installer permission level switches back to End user.

To set the user permission level to Advanced end user

- 1 Go to the main menu or any of its submenus: .
- 2 Press for more than 4 seconds.

Result: The user permission level switches to Adv. end user. Additional information is displayed and "+" is added to the menu title. The user permission level will stay in Adv. end user until set otherwise.

To set the user permission level to End user

- 1 Press for more than 4 seconds.

Result: The user permission level switches to End user. The user interface will return to the default home screen.

To modify an overview setting

Example: Modify [1-01] from 15 to 20.

- 1 Go to [A.8]: > Installer settings > Overview settings.
- 2 Go to the corresponding screen of the first part of the setting by using the and button.



INFORMATION

An additional 0-digit is added to the first part of the setting when you access the codes in the overview settings.

Example: [1-01]: "1" will result in "01".

Overview settings				
01				
00	01	15	02	03
04	05	06	07	
08	09	0a	0b	
0c	0d	0e	0f	
OK Confirm		Adjust	Scroll	

- 3 Go to the corresponding second part of the setting by using the and button.

Overview settings				
01				
01				
00	01	15	02	03
04	05	06	07	
08	09	0a	0b	
0c	0d	0e	0f	
OK Confirm		Adjust	Scroll	

Result: The value to be modified is now highlighted.

- 4 Modify the value by using the and button.

Overview settings				
01				
01				
00	01	20	02	03
04	05	06	07	
08	09	0a	0b	
0c	0d	0e	0f	
OK Confirm		Adjust	Scroll	

- 5 Repeat previous steps if you have to modify other settings.
- 6 Push to confirm the modification of the parameter.
- 7 At installer settings menu, press to confirm the settings.

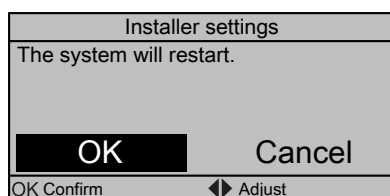

Result: The system will restart.

8.1.3 To copy the system settings from the first to the second user interface

If a second user interface is connected, the installer must first proceed below instructions for the proper configuration of the 2 user interfaces.

This procedure offers you also the possibility to copy the language set from one user interface to the other one: e.g. from EKRUCBL2 to EKRUCBL1.

- 1 When power is turned on for the first time, both user interfaces display:

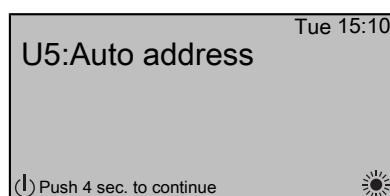

- 2 Push  for 4 seconds on the user interface on which you want to proceed to the quick wizard. This user interface is now the main user interface.

INFORMATION

During the quick wizard, the second user interface displays Busy and will NOT be possible to operate.

- 3 The quick wizard will guide you.
- 4 For proper operation of the system, the local data on the two user interfaces must be the same. If this is NOT the case, both user interfaces will display:

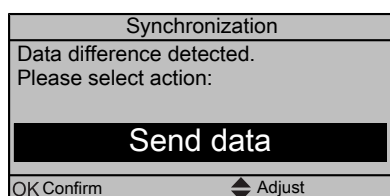

- 5 Select the required action:
 - Send data: the user interface you are operating contains the correct data and the data on the other user interface will be overwritten.
 - Receive data: the user interface you are operating does NOT contain the correct data and the data on the other user interface will be used to overwrite.
- 6 The user interface requests confirmation if you are sure to proceed.

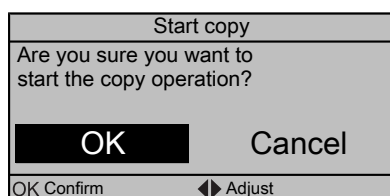

- 7 Confirm the selection on the screen by pushing  and all data (languages, schedules etc.) will be synchronised from the selected source user interface to the other one.

INFORMATION

- During the copying, both controllers will NOT allow operation.
- The copy operation can take up until 90 minutes.
- It is recommended to change installer settings, or the configuration of the unit, on the main user interface. If not, it can take up to 5 minutes before these changes are visible in the menu structure.

- 8 Your system is now set to be operated by the 2 user interfaces.

8.1.4 To copy the language set from the first to the second user interface

See "8.1.3 To copy the system settings from the first to the second user interface" on page 41.

8.1.5 Quick wizard: Set the system layout after first power ON

After first power ON of the system, you are guided on the user interface to do initial settings:

- language,
- date,
- time,
- system layout.

By confirming the system layout, you can proceed with the installation and commissioning of the system.

- 1 At power ON, the quick wizard starts as long as the system layout was NOT confirmed yet, by setting the language.

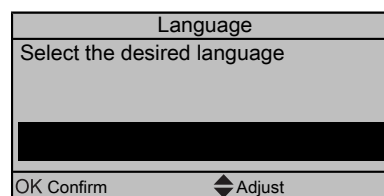

- 2 Set the current date and time.

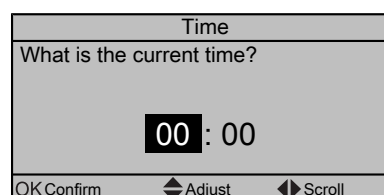
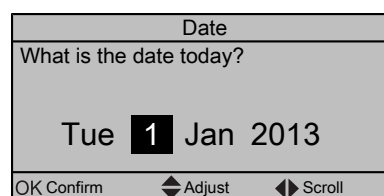

- 3 Set the system layout settings: Standard, Options, Capacities. For more details, see "8.2 Basic configuration" on page 42.

8 Configuration

A.2	System layout	1
Standard		
Options		
Capacities		
Confirm layout		
OK Select		Scroll

4 After configuration, select Confirm layout and press **OK**.

Confirm layout	
Please confirm the system layout. The system will restart and will be ready for first startup.	
OK	Cancel
OK Confirm	Adjust

5 The user interface re-initialises and you can proceed the installation by setting the other applicable settings and commissioning of the system.

When the installer settings are changed, the system will request to confirm. When confirmation is complete, the screen will shortly turn OFF and "busy" will be displayed for several seconds.

8.2 Basic configuration

8.2.1 Quick wizard: Language / time and date

#	Code	Description
[A.1]	N/A	Language
[1]	N/A	Time and date

8.2.2 Quick wizard: Standard

Space heating settings

The system can heat up a space. Depending on the type of application, the space heating settings must be made accordingly.

#	Code	Description
[A.2.1.7]	[C-07]	Unit control method: <ul style="list-style-type: none"> 0 (LWT control): Unit operation is decided based on the leaving water temperature regardless the actual room temperature and/or heating demand of the room. This is applicable for both temperature zones. 1 (Ext RT control): Unit operation is decided by the external thermostat or equivalent (e.g. heat pump convector). This is applicable for both temperature zones. 2 (RT control): Unit operation for the main temperature zone is decided based on the ambient temperature of the user interface. The additional temperature zone is controlled by the external thermostat.

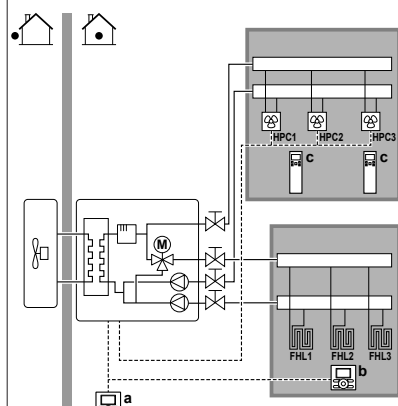
#	Code	Description
[A.2.1.B]	N/A	<p>Only if there are 2 user interfaces (1 installed in the room, 1 installed at the indoor unit):</p>  <ul style="list-style-type: none"> a: At unit b: In room as room thermostat c: Remote controller of the heat pump convectors <p>User interface location:</p> <ul style="list-style-type: none"> At unit: the other user interface is automatically set to In room and if RT control is selected act as room thermostat. In room (default): the other user interface is automatically set to At unit and if RT control is selected to act as room thermostat. Controlling the main zone.

#	Code	Description
[A.2.1.8]	[7-02]	<p>The system can supply leaving water to up to 2 water temperature zones. During configuration, the number of water zones must be set.</p> <p>Number of LWT zones: This unit is designed for 2 leaving water temperature zones. Do NOT change this setting.</p> <ul style="list-style-type: none"> 0 (1 LWT zone): N/A. 1 (2 LWT zones)(default): 2 leaving water temperature zones. The zone with the lowest leaving water temperature is called the main leaving water temperature zone. The zone with the highest leaving water temperature is called the additional leaving water temperature zone. In practice, the main leaving water temperature zone consists of underfloor heating and the additional water temperature zone consists of radiators or heat pump convectors. <ul style="list-style-type: none"> a: Add LWT zone b: Main LWT zone

#	Code	Description
[A.2.1.9]	[F-0D]	<p>When the space heating control is OFF by the user interface, the pump is always OFF. When the space heating control is On, you can select the desired pump operation mode (only applicable during space heating). This is applicable for both temperature zones.</p> <p>Pump operation mode:</p> <ul style="list-style-type: none"> 0 (Continuous): Continuous pump operation, regardless of thermo ON or OFF condition. Remark: continuous pump operation requires more energy than sample or request pump operation. <ul style="list-style-type: none"> a: Space heating control (user interface) b: OFF c: On d: Pump operation <p style="text-align: right;">continued >></p>

#	Code	Description
[A.2.1.9]	[F-0D]	<p><< continuation</p> <ul style="list-style-type: none"> 1 (Sample): The pump is ON when there is heating demand and the leaving water temperature has NOT reached the desired temperature yet. When thermo OFF condition occurs, the pump runs every 5 minutes to check the water temperature and demand heating if necessary. Remark: Sample is NOT available in external room thermostat control or room thermostat control. <ul style="list-style-type: none"> a: Space heating control (user interface) b: OFF c: On d: LWT temperature e: Actual f: Desired g: Pump operation <p style="text-align: right;">continued >></p>

#	Code	Description
[A.2.1.9]	[F-0D]	<p><< continuation</p> <ul style="list-style-type: none"> 2 (Request)(default): Pump operation based on request. Example: Using a room thermostat creates thermo ON/OFF condition. When there is no such demand, the pump is OFF. Remark: Request is NOT available in leaving water temperature control. <ul style="list-style-type: none"> a: Space heating control (user interface) b: OFF c: On d: Heating demand (by ext RT or RT) e: Pump operation

8.2.3 Quick wizard: Options

Domestic hot water settings

Following settings must be made accordingly.

8 Configuration

#	Code	Description
[A.2.2.1]	[E-05]	<p>DHW operation:</p> <p>Can the system prepare domestic hot water?</p> <ul style="list-style-type: none"> 0 (No): NOT installed. 1 (Yes)(default): Installed. Remark: The domestic hot water tank is by default installed. Do NOT change this setting.
[A.2.2.A]	[D-02]	<p>The indoor unit offers the possibility to connect a field supplied domestic hot water pump (On/OFF type). Depending on the installation and configuration on the user interface, we distinguish its functionality.</p> <p>DHW pump:</p> <ul style="list-style-type: none"> 0 (No)(default): NOT installed. 1 (Secondary rtrn): Installed for instant hot water when water is tapped. The end-user sets the operation timing (weekly schedule time) of the domestic hot water pump when it should run. Control of this pump is possible through the indoor unit. 2 (Disinf. shunt): Installed for disinfection. It runs when the disinfection function of the domestic hot water tank is running. No further settings are needed. <p>See also illustrations below.</p>

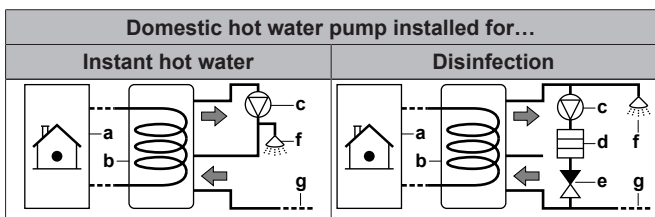

- a Indoor unit
- b Tank
- c Domestic hot water pump (field supply)
- d Heater element (field supply)
- e Non-return valve (field supply)
- f Shower (field supply)
- g Cold water

Thermostats and external sensors

Following combinations are possible to control the unit (not applicable when [C-07]=0):

When [C-07]=2 (RT control)

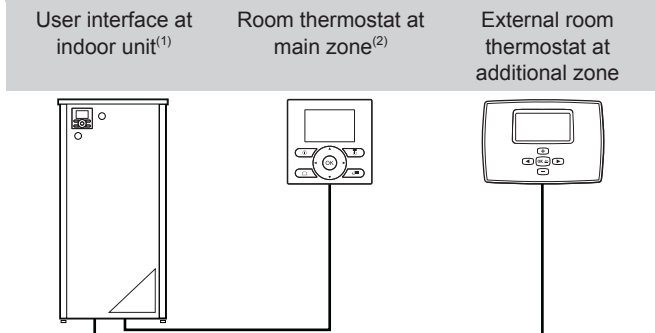

When [C-07]=1 (Ext RT control)

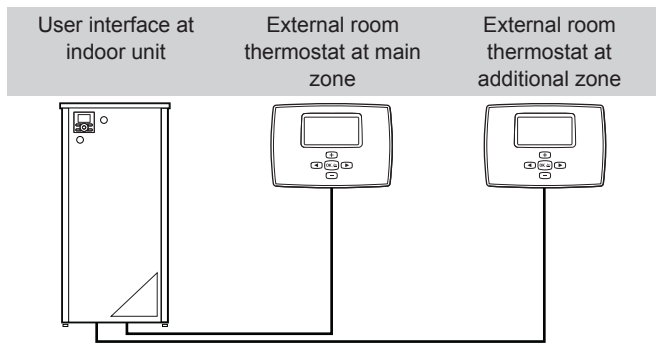

NOTICE

If an external room thermostat is used, the external room thermostat will control the room frost protection. However, the room frost protection is only possible if the leaving water temperature control on the unit's user interface is turned ON.

See "5 Application guidelines" on page 10.

#	Code	Description
[A.2.2.4]	[C-05]	<p>Contact type main</p> <p>In external room thermostat control, the contact type of the optional room thermostat or heat pump convactor for the main leaving water temperature zone must be set. See "5 Application guidelines" on page 10.</p> <ul style="list-style-type: none"> 1 (Thermo ON/OFF): The connected external room thermostat or heat pump convactor sends the heating demand by the same signal as it is connected to only 1 digital input (preserved for the main leaving water temperature zone) on the indoor unit (X2M/1). Select this value in case of a connection to the heat pump convactor (FWXV). 2 (H/C request)(default): The connected external room thermostat sends a heating demand and is connected to the digital input (preserved for the main leaving water temperature zone) on the indoor unit (X2M/1). Select this value in case of connection with the wired (EKRTWA) or wireless (EKRTR1) room thermostat.
[A.2.2.5]	[C-06]	<p>Contact type add.</p> <p>In external room thermostat control with 2 leaving water temperature zones, the type of the optional room thermostat for the additional leaving water temperature zone must be set. See "5 Application guidelines" on page 10.</p> <ul style="list-style-type: none"> 1 (Thermo ON/OFF): See Contact type main. Connected on the indoor unit (X2M/1a). 2 (H/C request)(default): See Contact type main. Connected on the indoor unit (X2M/1a).

(1) Not mandatory.

(2) When there is no user interface installed at the indoor unit, the user interface in the main zone will function as room thermostat AND user interface.

#	Code	Description
[A.2.2.B]	[C-08]	<p>External sensor</p> <p>When an optional external ambient sensor is connected, the type of the sensor must be set. See "5 Application guidelines" on page 10.</p> <ul style="list-style-type: none"> 0 (No)(default): NOT installed. The thermistor in the user interface and in the outdoor unit are used for measurement. 1 (Outdoor sensor): Installed. The external outdoor sensor will be used to measure the outdoor ambient temperature. Remark: For some functionality, the temperature sensor in the outdoor unit is still used. 2 (Room sensor): Installed. The temperature sensor in the user interface is NOT used anymore. Remark: This value has only meaning in room thermostat control.

Digital I/O PCB

Modification of these settings is only needed when the optional digital I/O PCB is installed. The digital I/O PCB has multiple functionality which need to be configured. See ["5 Application guidelines" on page 10](#).

#	Code	Description
[A.2.2.6.1]	[C-02]	Not applicable.
[A.2.2.6.2]	[D-07]	Not applicable (read only).
[A.2.2.6.3]	[C-09]	<p>Alarm output</p> <p>Indicates the logic of the alarm output on the digital I/O PCB during malfunctioning.</p> <ul style="list-style-type: none"> 0 (Normally open)(default): The alarm output will be powered when an alarm occurs. By setting this value, a distinction is made between malfunctioning and detection of a power failure of the unit. 1 (Normally closed): The alarm output will NOT be powered when an alarm occurs.
[A.2.2.6.4]	[F-04]	<p>Bottom plate heater</p> <p>Only applicable for EHVZ16. Indicates if an optional bottom plate heater is installed on the outdoor unit. The power of the bottom plate heater is in this case supplied by the indoor unit.</p> <ul style="list-style-type: none"> 0 (No)(default): NOT installed. 1 (Yes): Installed. Remark: If this value is set, the output on the digital I/O PCB cannot be used for space heating output. See "5 Application guidelines" on page 10.

Alarm output logic

[C-09]	Alarm	No alarm	No power supply to unit
0 (default)	Closed output	Open output	Open output
1	Open output	Closed output	

Demand PCB

The demand PCB is used to enable the power consumption control by digital inputs. See ["5 Application guidelines" on page 10](#).

#	Code	Description
[A.2.2.7]	[D-04]	<p>Demand PCB</p> <p>Only applicable for EHVZ04+08. Indicates if the optional demand PCB is installed.</p> <ul style="list-style-type: none"> 0 (No)(default) 1 (Pwr consmp ctrl)

Energy metering

When energy metering is performed by the use of external power meters, configure the settings as described below. Select the pulse frequency output of each power meter in accordance with the power meter specifications. It is possible to connect (up to 2) power meters with different pulse frequencies. When only 1 or no power meter is used, select No to indicate the corresponding pulse input is NOT used.

#	Code	Description
[A.2.2.8]	[D-08]	<p>Optional external kWh meter 1:</p> <ul style="list-style-type: none"> 0 (No): NOT installed 1: Installed (0.1 pulse/kWh) 2: Installed (1 pulse/kWh) 3: Installed (10 pulse/kWh) 4: Installed (100 pulse/kWh) 5: Installed (1000 pulse/kWh)
[A.2.2.9]	[D-09]	<p>Optional external kWh meter 2:</p> <ul style="list-style-type: none"> 0 (No): NOT installed 1: Installed (0.1 pulse/kWh) 2: Installed (1 pulse/kWh) 3: Installed (10 pulse/kWh) 4: Installed (100 pulse/kWh) 5: Installed (1000 pulse/kWh)

8.2.4 Quick wizard: Capacities (energy metering)

The capacities of all electrical heaters must be set for the energy metering and/or power consumption control feature to work properly. When measuring the resistance value of each heater, you can set the exact heater capacity and this will lead to more accurate energy data.

#	Code	Description
[A.2.3.2]	[6-03]	<p>BUH: step 1: The capacity of the first step of the backup heater at nominal voltage. Nominal value 3 kW. Default: 3 kW.</p> <p>Range: 0~10 kW (in steps of 0.2 kW)</p>
[A.2.3.6]	[6-07]	<p>Bottom plate heater: Only applies to an optional bottom plate heater (EKBPPTH16A). The capacity of the optional bottom plate heater at nominal voltage. Default: 0 W.</p> <p>Range: 0~200 W (in steps of 10 W)</p>

8 Configuration

8.2.5 Space heating control

The basic required settings in order to configure the space heating of your system are described in this chapter. The weather-dependent installer settings define the parameters for the weather-dependent operation of the unit. When weather-dependent operation is active, the water temperature is determined automatically depending on the outdoor temperature. Low outdoor temperatures will result in warmer water and vice versa. During weather-dependent operation, the user has the possibility to shift up or down the target water temperature by a maximum of 5°C.

See the user reference guide and/or operation manual for more details about this function.

Leaving water temperature: Main zone

#	Code	Description
[A.3.1.1.1]	N/A	<p>LWT setpoint mode:</p> <ul style="list-style-type: none"> Fixed (default) The desired leaving water temperature is: <ul style="list-style-type: none"> NOT weather-dependent (i.e. does NOT depend on the outdoor ambient temperature) fixed in time (i.e., NOT scheduled) Weather dep.: The desired leaving water temperature is: <ul style="list-style-type: none"> weather-dependent (i.e. depends on the outdoor ambient temperature) fixed in time (i.e., NOT scheduled) <p style="text-align: right;">continued >></p>

#	Code	Description
[A.3.1.1.1]	N/A	<p><< continuation</p> <ul style="list-style-type: none"> Fixed/scheduled: The desired leaving water temperature is: <ul style="list-style-type: none"> NOT weather-dependent (i.e., does NOT depend on the outdoor ambient temperature) according a schedule. The scheduled actions consists of desired shift actions, either preset or custom. <p>Remark: This value can only be set in leaving water temperature control.</p> WD/scheduled: The desired leaving water temperature is: <ul style="list-style-type: none"> weather-dependent (i.e., does depend on the outdoor ambient temperature) according a schedule. The scheduled actions consists of desired leaving water temperatures either preset or custom. <p>Remark: This value can only be set in leaving water temperature control.</p>

#	Code	Description
[7.7.1.1]	[1-00] [1-01] [1-02] [1-03]	<p>Set weather-dependent heating:</p> <p> <ul style="list-style-type: none"> T_t: Target leaving water temperature (main) T_a: Outdoor temperature </p> <p style="text-align: right;">continued >></p>

#	Code	Description
[7.7.1.1]	[1-00] [1-01] [1-02] [1-03]	<p><< continuation</p> <ul style="list-style-type: none"> [1-00]: Low outdoor ambient temperature. -40°C~+5°C (default: -10°C) [1-01]: High outdoor ambient temperature. 10°C~25°C (default: 15°C) [1-02]: Desired leaving water temperature when the outdoor temperature equals or drops below the low ambient temperature. [9-01]~[9-00] (default: 35°C). Note: This value should be higher than [1-03] as for low outdoor temperatures warmer water is required. [1-03]: Desired leaving water temperature when the outdoor temperature equals or rises above the high ambient temperature. [9-01]~min(45, [9-00])°C (default: 25°C). Note: This value should be lower than [1-02] as for high outdoor temperatures less warm water is required.

Leaving water temperature: Additional zone

Only applicable if 2 leaving water temperature zones are present.

#	Code	Description
[A.3.1.2.1]	N/A	<p>LWT setpoint mode:</p> <ul style="list-style-type: none"> Fixed (default): The desired leaving water temperature is: <ul style="list-style-type: none"> NOT weather-dependent (i.e. does NOT depend on the outdoor ambient temperature) fixed in time (i.e., NOT scheduled) Weather dep.: The desired leaving water temperature is: <ul style="list-style-type: none"> weather-dependent (i.e. depends on the outdoor ambient temperature) fixed in time (i.e., NOT scheduled) Fixed/scheduled: The desired leaving water temperature is: <ul style="list-style-type: none"> NOT weather-dependent (i.e., does NOT depend on the outdoor ambient temperature) according a schedule. The scheduled actions are On or OFF. <p>Remark: This value can only be set in leaving water temperature control.</p> WD/scheduled: The desired leaving water temperature is: <ul style="list-style-type: none"> weather-dependent (i.e., does depend on the outdoor ambient temperature) according a schedule. The scheduled actions are On or OFF. <p>Remark: This value can only be set in leaving water temperature control.</p>

#	Code	Description
[7.7.2.1]	[0-00] [0-01] [0-02] [0-03]	<p>Set weather-dependent heating:</p> <p>The graph plots Target leaving water temperature (T_t) on the vertical axis against Outdoor temperature (T_a) on the horizontal axis. The curve starts at a constant level corresponding to code [0-01] until it reaches the outdoor temperature [0-03]. From [0-03], the temperature decreases linearly until it reaches the outdoor temperature [0-02], where it levels off at the value corresponding to code [0-00].</p> <ul style="list-style-type: none"> T_t: Target leaving water temperature (additional) T_a: Outdoor temperature <p style="text-align: right;">continued >></p>

#	Code	Description
[7.7.2.1]	[0-00] [0-01] [0-02] [0-03]	<p><< continuation</p> <ul style="list-style-type: none"> [0-03]: Low outdoor ambient temperature. $-40^{\circ}\text{C}\sim+5^{\circ}\text{C}$ (default: -10°C) [0-02]: High outdoor ambient temperature. $10^{\circ}\text{C}\sim25^{\circ}\text{C}$ (default: 15°C) [0-01]: Desired leaving water temperature when the outdoor temperature equals or drops below the low ambient temperature. [9-05]~[9-06] (default: 45°C). Note: This value should be higher than [0-00] as for low outdoor temperatures warmer water is required. [0-00]: Desired leaving water temperature when the outdoor temperature equals or rises above the high ambient temperature. [9-05]~min(45, [9-06])$^{\circ}\text{C}$ (default: 35°C). Note: This value should be lower than [0-01] as for high outdoor temperatures less warm water is required.

Leaving water temperature: Delta T source

When both temperature zones have heating demand, both pumps will operate at full speed. When only 1 temperature zone has heating demand, only 1 pump will operate and the flow will be controlled to realize a temperature difference between the entering and the leaving water of [9-09] on that zone. Only 1 temperature difference [9-09] can be selected, this is then applicable for both temperature zones.

#	Code	Description
[A.3.1.3.1]	[9-09]	Heating: Required temperature difference between entering and leaving water. Range: $3^{\circ}\text{C}\sim10^{\circ}\text{C}$ (in steps of 1°C ; default value: 5°C).

Leaving water temperature: Modulation

Only applicable in case of room thermostat control. When using the room thermostat functionality, the customer needs to set the desired room temperature. The unit will supply hot water to the heat emitters and the room will be heated. Additionally, also the desired leaving water temperature must be configured: when turning on the modulation, the desired leaving water temperature will be calculated automatically by the unit (based on the preset temperatures, if weather-dependent is selected, modulation will be done based on the desired weather-dependent temperatures); when turning off the modulation, you can set the desired leaving water temperature on the user interface. Moreover, with the modulation turned on, the desired leaving water temperature is lowered or raised in function of the desired room temperature and the difference between the actual and the desired room temperature. This results in:

- stable room temperatures exactly matching the desired temperature (higher comfort level)
- less On/OFF cycles (lower noise level, higher comfort and higher efficiency)
- water temperatures as low as possible to match the desired temperature (higher efficiency)

8 Configuration

#	Code	Description
[A.3.1.1.5]	[8-05]	Modulated LWT: <ul style="list-style-type: none"> No (default): disabled. <p>Note: The desired leaving water temperature needs to be set on the user interface.</p> Yes: enabled. <p>Note: The desired leaving water temperature can only be read out on the user interface</p>



INFORMATION

Only applicable for the main zone.



INFORMATION

When leaving water temperature modulation is enabled, the weather-dependent curve needs to be set to a higher position than [8-06] plus the minimum leaving water temperature setpoint required to reach a stable condition on the comfort setpoint for the room. To increase efficiency, modulation can lower the leaving water setpoint. By setting the weather-dependent curve to a higher position, it cannot drop below the minimum setpoint. Refer to the illustration below.

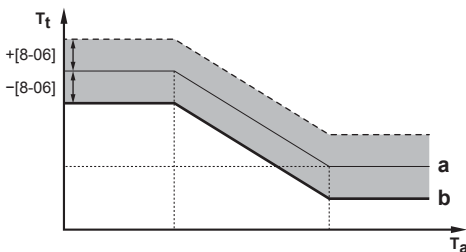

- a Weather-dependent curve
- b Minimum leaving water temperature setpoint required to reach a stable condition on the comfort setpoint for the room.

Leaving water temperature: Emitter type

This setting only applies to the main zone. Only applicable in case of room thermostat control. Depending on the system water volume and the heat emitters type, the heat up of a space can take longer. This setting can compensate for a slow or a quick heating system during the heat up cycle.

Note: The setting of the emitter type will influence the maximum modulation of the desired leaving water temperature.

Therefore it is important to set this correctly.

#	Code	Description
[A.3.1.1.7]	[9-0B]	Emitter type: Set for the main temperature zone. Reaction time of the system: <ul style="list-style-type: none"> Quick Example: Small water volume and fan coils. Slow Example: Large water volume, floor heating loops.

8.2.6 Domestic hot water control

Configuring the desired tank temperature

The domestic hot water can be prepared in 3 different ways. They differ from each other by the way the desired tank temperature is set and how the unit acts upon it.

#	Code	Description
[A.4.1]	[6-0D]	Domestic hot water Type: <ul style="list-style-type: none"> 0 (Reheat only): Only reheat operation is allowed. 1 (Reheat + sched.): The domestic hot water tank is heated according to a schedule and between the scheduled heatup cycles, reheat operation is allowed. 2 (Scheduled only): The domestic hot water tank can ONLY be heated according to a schedule.

See "8.3.2 Domestic hot water control: advanced" on page 51 for more details.



INFORMATION

There is a risk of space heating capacity shortage/comfort problem (in case of frequent domestic hot water operation, frequent and long space heating interruption will happen) when selecting [6-0D]=0 ([A.4.1] Domestic hot water Type=Reheat only).

Maximum DHW temperature setpoint

The maximum temperature that users can select for the domestic hot water. You can use this setting to limit the temperatures at the hot water taps.



INFORMATION

During disinfection of the domestic hot water tank, the DHW temperature can exceed this maximum temperature.



INFORMATION

Limit the maximum hot water temperature according to the applicable legislation.

#	Code	Description
[A.4.5]	[6-0E]	Maximum setpoint The maximum temperature that users can select for the domestic hot water. You can use this setting to limit the temperature at the hot water taps. Range: 40°C~60°C (default: 60°C). The maximum temperature is NOT applicable during disinfection function. See disinfection function.

8.2.7 Contact/helpdesk number

#	Code	Description
[6.3.2]	N/A	Number that users can call in case of problems.

8.3 Advanced configuration/ optimization

8.3.1 Space heating operation: advanced

Preset leaving water temperature

You can define preset leaving water temperatures:

- economic (denotes the desired leaving water temperature which results in the lowest energy consumption)
- comfort (denotes the desired leaving water temperature which results in the highest energy consumption).

Preset values make it easy to use the same value in the schedule or to adjust the desired leaving water temperature according to the room temperature (see modulation). If you later want to change the value, you ONLY have to do it in one place. Depending on whether the desired leaving water temperature is weather dependent or NOT, the desired shift values or the absolute desired leaving water temperature should be specified.

NOTICE

The preset leaving water temperatures are ONLY applicable for the main zone, as the schedule for the additional zone consists of On/OFF actions.

NOTICE

Select preset leaving water temperatures in accordance with the design and selected heat emitters to ensure the balance between desired room and leaving water temperatures.

#	Code	Description
Preset leaving water temperature for the main leaving water temperature zone in case of NOT weather dependent		
[7.4.2.1]	[8-09]	Comfort (heating) [9-01]~[9-00] (default: 35°C)
[7.4.2.2]	[8-0A]	Eco (heating) [9-01]~[9-00] (default: 33°C)
Preset leaving water temperature (shift value) for the main leaving water temperature zone in case of weather dependent		
[7.4.2.5]	N/A	Comfort (heating) -10°C~+10°C (default: 0°C)
[7.4.2.6]	N/A	Eco (heating) -10°C~+10°C (default: -2°C)

Temperature ranges (leaving water temperatures)

The purpose of this setting is to prevent selecting a wrong (i.e. too hot or too cold) leaving water temperature. Therefore the available desired heating temperature range can be configured.

NOTICE

In case of a floor heating application it is important to limit the maximum leaving water temperature at heating operation according to the specifications of the floor heating installation.

NOTICE

- When adjusting the leaving water temperature ranges, all desired leaving water temperatures are also adjusted to guarantee they are between the limits.
- Always balance between the desired leaving water temperature with the desired room temperature and/or the capacity (according to the design and selection of the heat emitters). The desired leaving water temperature is the result of several settings (preset values, shift values, weather dependent curves, modulation). As a result, too high or too low leaving water temperatures could occur which lead to overtemperatures or capacity shortage. By limiting the leaving water temperature range to adequate values (depending on the heat emitter), such situations can be avoided.

Example: Set the minimum leaving water temperature to 28°C to avoid NOT to be able to heat up the room: leaving water temperatures MUST be sufficiently higher than the room temperatures (in heating).

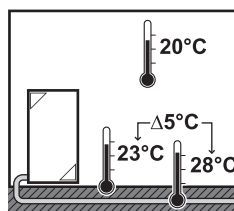

#	Code	Description
Leaving water temperature range for the main leaving water temperature zone (= the leaving water temperature zone with the lowest leaving water temperature)		
[A.3.1.1.2.2]	[9-00]	Maximum temp (heating) 37°C~55°C (default: 55°C)
[A.3.1.1.2.1]	[9-01]	Minimum temp (heating) 15°C~37°C (default: 25°C)
Leaving water temperature range for the additional leaving water temperature zone (= the leaving water temperature zone with the highest leaving water temperature)		
[A.3.1.2.2.2]	[9-06]	Maximum temp (heating) 37°C~55°C (default: 55°C)
[A.3.1.2.2.1]	[9-05]	Minimum temp (heating) 15°C~37°C (default: 25°C)

Leaving water temperature overshoot temperature

This function defines how much the water temperature may rise above the desired leaving water temperature before the compressor stops. The compressor will startup again when the leaving water temperature drops below the desired leaving water temperature.

#	Code	Description
N/A	[9-04]	1°C~4°C (default: 1°C)

Leaving water temperature compensation around 0°C

In heating operation, the desired leaving water temperature is locally increased around an outdoor temperature of 0°C. This compensation can be selected when using an absolute or a weather dependent desired temperature (see illustration below). Use this setting to compensate for possible heat losses of the building due to the evaporation of melted ice or snow (e.g. in cold region countries).

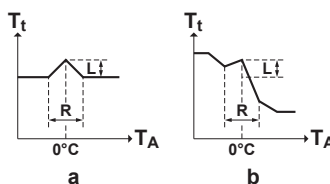

- a Absolute desired LWT
- b Weather dependent desired LWT
- TA Ambient temperature (°C)
- Tt Desired leaving water temperature

#	Code	Description
N/A	[D-03]	<ul style="list-style-type: none"> 0 (disabled) (default) 1 (enabled) L=2°C, R=4°C (-2°C<TA<2°C) 2 (enabled) L=4°C, R=4°C (-2°C<TA<2°C) 3 (enabled) L=2°C, R=8°C (-4°C<TA<4°C) 4 (enabled) L=4°C, R=8°C (-4°C<TA<4°C)

8 Configuration

Leaving water temperature maximum modulation

ONLY applicable in room thermostat control and when modulation is enabled. The maximum modulation (=variance) on the desired leaving water temperature decided on the difference between the actual and desired room temperature, e.g. 3°C modulation means the desired leaving water temperature can be increased or lowered by 3°C. Increasing the modulation results in better performance (less On/OFF, faster heat up), but note that depending on the heat emitter, there MUST ALWAYS be a balance (refer to the design and selection of the heat emitters) between the desired leaving water temperature and the desired room temperature.

#	Code	Description
N/A	[8-06]	0°C~10°C (default: 3°C)

Temperature ranges (room temperature)

ONLY applicable in room thermostat control. In order to save energy by preventing overheating the room, you can limit the range of the room temperature.

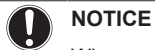

NOTICE

When adjusting the room temperature ranges, all desired room temperatures are also adjusted to guarantee they are between the limits.

#	Code	Description
Room temp. range		
[A.3.2.1.2]	[3-06]	Maximum temp (heating) 18°C~30°C (default: 30°C)
[A.3.2.1.1]	[3-07]	Minimum temp (heating) 12°C~18°C (default: 12°C)

Room temperature step

ONLY applicable in room thermostat control and when the temperature is displayed in °C.

#	Code	Description
[A.3.2.4]	N/A	Room temp. step <ul style="list-style-type: none"> 1°C (default). The desired room temperature on the user interface is settable per 1°C. 0.5°C. The desired room temperature on the user interface is settable per 0.5°C. The actual room temperature is displayed with an accuracy of 0.1°C.

Room temperature hysteresis

ONLY applicable in case of room thermostat control. The hysteresis band around the desired room temperature is settable. It is recommended NOT to change the room temperature hysteresis as it is set for an optimal use of the system.

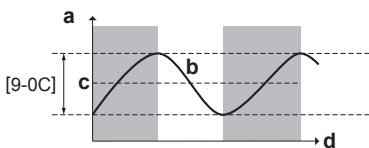

- a Room temperature
- b Actual room temperature
- c Desired room temperature
- d Time

#	Code	Description
N/A	[9-0C]	1°C~6°C (default: 1°C)

Room temperature offset

ONLY applicable in case of room thermostat control. You can calibrate the (external) room temperature sensor. It is possible to give an offset to the room thermistor value measured by the user

interface or by the external room sensor. The settings can be used to compensate for situations where the user interface or external room sensor CANNOT be installed on the ideal installation location (see installation manual and/or installer reference guide).

#	Code	Description
Room temp. offset: Offset on the actual room temperature measured on the user interface sensor.		
[A.3.2.2]	[2-0A]	-5°C~+5°C, step 0.5°C (default: 0°C)
Ext. room sensor offset: ONLY applicable if the external room sensor option is installed and configured (see [C-08])		
[A.3.2.3]	[2-09]	-5°C~+5°C, step 0.5°C (default: 0°C)

Room frost protection

Room frost protection prevents the room from getting too cold. This setting behaves differently depending on the set unit control method ([C-07]). Perform actions according to the table below:

Unit control method ([C-07])	Room frost protection
Room thermostat control ([C-07]=2)	Allow for the room thermostat to take care of room frost protection: <ul style="list-style-type: none"> Set [2-06] to "1" Set the room antifrost temperature ([2-05]).
External room thermostat control ([C-07]=1)	Allow for the external room thermostat to take care of room frost protection: <ul style="list-style-type: none"> Turn ON the leaving water temperature home page. Set auto emergency ([A.5.1.2]) to "1".
Leaving water temperature control ([C-07]=0)	Room frost protection is NOT guaranteed.



NOTICE

If the system does NOT contain a backup heater, do NOT change the default room antifrost temperature.



INFORMATION

If an U4 error occurs, room frost protection is NOT guaranteed.

Refer to the sections below for detailed information on room frost protection in relation to the applicable unit control method.

[C-07]=2: room thermostat control

Under room thermostat control, room frost protection is guaranteed, even if the room temperature home page is OFF on the user interface. When room frost protection ([2-06]) is enabled and the room temperature drops below the room antifrost temperature ([2-05]), the unit will supply leaving water to the heat emitters to heat up the room again.

#	Code	Description
N/A	[2-06]	Room frost protection <ul style="list-style-type: none"> 0: disabled 1: enabled (default)
N/A	[2-05]	Room antifrost temperature 4°C~16°C (default: 12°C)

**INFORMATION**

If an U5 error occurs:

- when 1 user interface is connected, room frost protection is NOT guaranteed,
- when 2 user interfaces are connected and the second user interface used for room temperature control is disconnected (due to miswiring, damage of the cable), then room frost protection is NOT guaranteed.

**NOTICE**

If Emergency is set to Manual ([A.5.1.2]=0), and the unit is triggered to start emergency operation, the user interface will ask confirmation before starting. Room frost protection is active even if the user does NOT confirm emergency operation.

[C-07]=1: external room thermostat control

Under external room thermostat control, room frost protection is guaranteed by the external room thermostat, provided that the leaving water temperature home page is ON on the user interface, and the auto emergency setting ([A.5.1.2]) is set to "1".

Additionally, limited frost protection by the unit is possible:

In case of...	...then the following applies:
Two leaving water temperature zones	<ul style="list-style-type: none"> ▪ When the leaving water temperature home page is OFF, and the outdoor ambient temperature drops below 4°C, then the unit will supply leaving water to the heat emitters to heat up the room again, and the leaving water temperature setpoint will be lowered by 5°C. ▪ When the leaving water temperature home page is ON, the outdoor ambient temperature drops below 4°C, then the unit will supply leaving water to the heat emitters to heat up the room again, and the leaving water temperature setpoint will be lowered by 5°C.

**NOTICE**

For the (limited) frost protection to be possible, auto emergency MUST be set to Automatic ([A.5.1.2]=1).

[C-07]=0: leaving water temperature control

Under leaving water temperature control, room frost protection is NOT guaranteed. However, if [2-06] is set to "1", limited frost protection by the unit is possible:

- When the leaving water temperature home page is OFF and the outdoor ambient temperature drops below 4°C, then the unit will supply leaving water to the heat emitters to heat up the room again, and the leaving water temperature setpoint will be lowered by 5°C.
- When the leaving water temperature home page is ON, then the unit will supply leaving water to the heat emitters to heat up the room according to normal logic.

**NOTICE**

For the (limited) frost protection to be possible, auto emergency MUST be set to Automatic ([A.5.1.2]=1).

Shut-off valve

The following is only applicable in case of 2 leaving water temperature zones. In case of 1 leaving water temperature zone, connect the shut-off valve to the heating output.

The shut-off valve, which is in the main leaving water temperature zone, output is configurable.

**INFORMATION**

During defrost operation, the shut-off valve is ALWAYS opened.

Thermo On/OFF: the valve closes, depending on [F-0B] when there is no heating demand from the main zone.

#	Code	Description
[A.3.1.1.6.1]	[F-0B]	The shut-off valve: <ul style="list-style-type: none"> ▪ 0 (No)(default): is NOT influenced by heating demand. ▪ 1 (Yes): closes when there is NO heating demand.

**INFORMATION**

The setting [F-0B] is only valid when there is a thermostat or external room thermostat request setting (NOT in case of leaving water temperature setting).

Operation range

Depending on the average outdoor temperature, the operation of the unit in space heating is prohibited.

Space heating OFF temp: When the averaged outdoor temperature raises above this value, space heating is turned OFF to avoid overheating.

#	Code	Description
[A.3.3.1]	[4-02]	<ul style="list-style-type: none"> ▪ EHVZ04+08: 14°C~35°C (default: 25°C) ▪ EHVZ16: 14°C~35°C (default: 35°C)

8.3.2 Domestic hot water control: advanced**Preset tank temperatures**

Only applicable when domestic hot water preparation is scheduled or scheduled + reheat.

You can define preset tank temperatures:

- storage economic
- storage comfort
- reheat

Preset values make it easy to use the same value in the schedule. If you later want to change the value, you only have to do it in 1 place (see also operation manual and/or user reference guide).

Storage comfort

When programming the schedule, you can make use of the tank temperatures set as preset values. The tank will then heat up until these setpoint temperatures have been reached. Additionally, a storage stop can be programmed. This feature puts a stop to tank heating even if the setpoint has NOT been reached. Only program a storage stop when tank heating is absolutely undesirable.

#	Code	Description
[7.4.3.1]	[6-0A]	30°C~[6-0E]°C (default: 60°C)

Storage eco

The storage economic temperature denotes the lower desired tank temperature. It is the desired temperature when a storage economic action is scheduled (preferably during day).

8 Configuration

#	Code	Description
[7.4.3.2]	[6-0B]	30°C~min(50, [6-0E])°C (default: 45°C)

Reheat

The desired reheat tank temperature is used:

- in reheat mode or scheduled + reheat mode: The guaranteed minimum tank temperature is set by $T_{HP\ OFF}$ [6-08], which is either [6-0C] or the weather dependent setpoint, minus the reheat hysteresis. If the tank temperature drops below this value, the tank is heated up.
- during storage comfort, to prioritize the domestic hot water preparation. When the tank temperature raises above this value, domestic hot water preparation and space heating is executed sequentially.

#	Code	Description
[7.4.3.3]	[6-0C]	30°C~min(50, [6-0E])°C (default: 45°C)

Weather dependent

The weather dependent installer settings define the parameters for the weather dependent operation of the unit. When weather dependent operation is active the desired tank temperature is determined automatically depending on the averaged outdoor temperature: low outdoor temperatures will result in higher desired tank temperatures as the cold water tap is colder and vice versa. In case of scheduled or scheduled+reheat domestic hot water preparation, the storage comfort temperature is weather dependent (according to the weather dependent curve), the storage economic and reheat temperature are NOT weather dependent. In case of reheat only domestic hot water preparation, the desired tank temperature is weather dependent (according to the weather dependent curve). During weather dependent operation, the end-user cannot adjust the desired tank temperature on the user interface.

#	Code	Description
[A.4.6]	N/A	Weather dependent desired tank temperature is: <ul style="list-style-type: none"> Fixed (default): disabled. All desired tank temperature are NOT weather dependent. Weather dep.: enabled. In scheduled or scheduled+reheat mode, the storage comfort temperature is weather dependent. Storage economic and reheat temperatures are NOT weather dependent. In reheat mode, the desired tank temperature is weather dependent. <p>Note: When the displayed tank temperature is weather dependent, it cannot be adjusted on the user interface.</p>

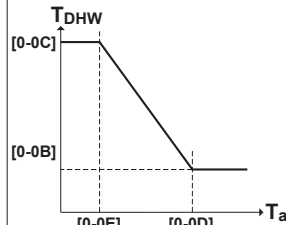
#	Code	Description
[A.4.7]	[0-0E] [0-0D] [0-0C] [0-0B]	Weather-dependent curve  <ul style="list-style-type: none"> T_{DHW}: The desired tank temperature. T_a: The (averaged) outdoor ambient temperature [0-0E]: low outdoor ambient temperature: -40°C~5°C (default: -10°C) [0-0D]: high outdoor ambient temperature: 10°C~25°C (default: 15°C) [0-0C]: desired tank temperature when the outdoor temperature equals or drops below the low ambient temperature: 45°C~[6-0E]°C (default: 60°C) [0-0B]: desired tank temperature when the outdoor temperature equals or rises above the high ambient temperature: 35°C~[6-0E]°C (default: 55°C)

Limits on heat pump operation

In domestic hot water operation, following hysteresis values can be set for the heat pump operation:

#	Code	Description
N/A	[6-00]	The temperature difference determining the heat pump ON temperature. Range: 2°C~20°C (default: 2°C)
N/A	[6-01]	The temperature difference determining the heat pump OFF temperature. Range: 0°C~10°C (default: 2°C)

Example:

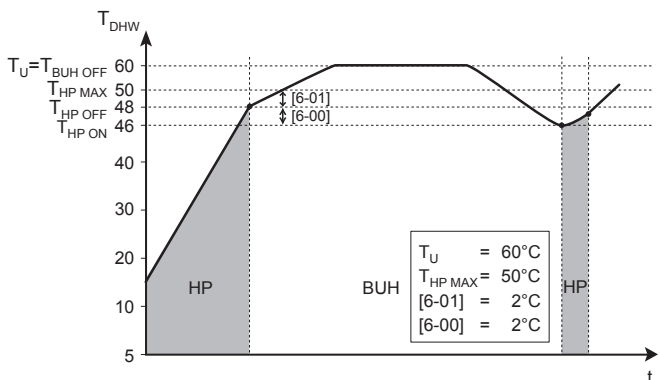

- BUH** Backup heater
HP Heat pump. If heating up time by the heat pump takes too long, auxiliary heating by the backup heater can take place
 $T_{BUH\ OFF}$ Backup heater OFF temperature (T_U)
 $T_{HP\ MAX}$ Maximum heat pump temperature at sensor in domestic hot water tank
 $T_{HP\ OFF}$ Heat pump OFF temperature ($T_{HP\ MAX}$ - [6-01])
 $T_{HP\ ON}$ Heat pump ON temperature ($T_{HP\ OFF}$ - [6-00])
 T_{DHW} Domestic hot water temperature

T_u User set point temperature (as set on the user interface)
 t Time

Timers for simultaneous request space and domestic hot water operation

#	Code	Description
N/A	[8-00]	Do not change. (default: 1)
N/A	[8-01]	Maximum running time for domestic hot water operation. Domestic hot water heating stops even when the target domestic hot water temperature is NOT reached. The actual maximum running time also depends on setting [8-04]. <ul style="list-style-type: none"> When system layout = Room thermostat control: This preset value is only taken into account if there is a request for space heating. If there is NO request for space heating, the tank is heated until the setpoint has been reached. When system layout \neq Room thermostat control: This preset value is always taken into account. Range: 5~95 minutes (default: 30)
N/A	[8-02]	Anti-recycling time. Minimum time between two cycles for domestic hot water. The actual anti-recycling time also depends on setting [8-04]. Range: 0~10 hours (default: 0.5) (step: 0.5 hour). Remark: The minimum time is 1/2 hour even when the selected value is 0.
N/A	[8-04]	Additional running time for the maximum running time depending on the outdoor temperature [4-02]. Range: 0~95 minutes (default: 95).

[8-02]: Anti-recycling time

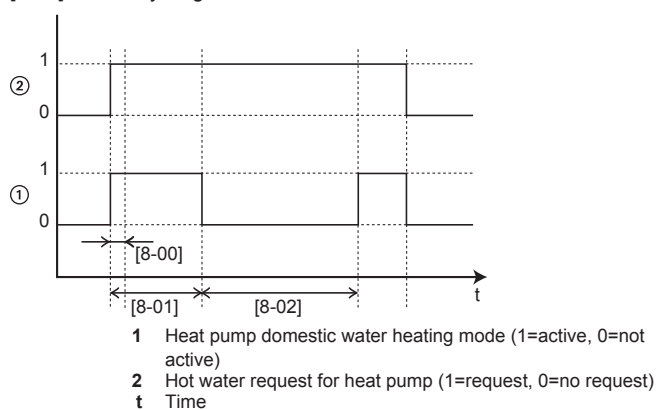

[8-04]: Additional running time at [4-02]/[F-01]

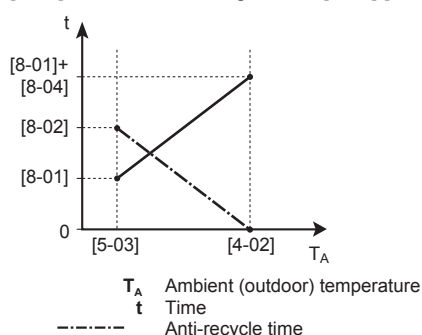

— Maximum running current

Disinfection

The disinfection function disinfects the domestic hot water tank by periodically heating the domestic hot water to a specific temperature.



CAUTION

The disinfection function settings **MUST** be configured by the installer according to the applicable legislation.

#	Code	Description
[A.4.4.2]	[2-00]	Operation day: <ul style="list-style-type: none"> 0: Each day 1: Monday 2: Tuesday 3: Wednesday 4: Thursday 5: Friday 6: Saturday 7: Sunday
[A.4.4.1]	[2-01]	Disinfection <ul style="list-style-type: none"> 0: No 1: Yes
[A.4.4.3]	[2-02]	Start time: 00~23:00, step: 1:00.
[A.4.4.4]	[2-03]	Temperature target: 60°C (fixed).
[A.4.4.5]	[2-04]	Duration: 40~60 minutes, default: 40 minutes.

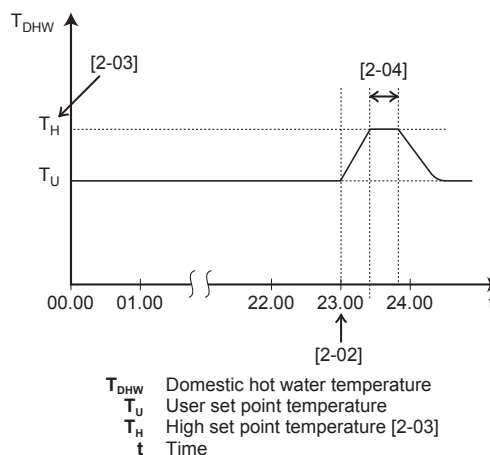

WARNING

Be aware that the domestic hot water temperature at the hot water tap will be equal to the value selected in field setting [2-03] after a disinfection operation.

When the high domestic hot water temperature can be a potential risk for human injuries, a mixing valve (field supply) shall be installed at the hot water outlet connection of the domestic hot water tank. This mixing valve shall secure that the hot water temperature at the hot water tap never rise above a set maximum value. This maximum allowable hot water temperature shall be selected according to the applicable legislation.



CAUTION

Be sure that the disinfection function start time [A.4.4.3] with defined duration [A.4.4.5] is NOT interrupted by possible domestic hot water demand.

8 Configuration

i INFORMATION

In case of error code AH and no interruption of the disinfection function occurred due to domestic hot water tapping, following actions are recommended:

- When the Domestic hot water > Type > Reheat or Reheat + sched. is selected, it is recommended to program the start-up of the disinfection function at least 4 hours later than the last expected large hot water tapping. This start-up can be set by installer settings (disinfection function).
- When the Domestic hot water > Type > Scheduled only is selected, it is recommended to program a Storage eco 3 hours before the scheduled start-up of the disinfection function to preheat the tank.

i INFORMATION

Disinfection function is restarted in case the domestic hot water temperature drops 5°C below the disinfection target temperature within the duration time.

i INFORMATION

An AH error occurs if you do the following during disinfection:

- Set the user permission level to Installer.
- Go to the DHW tank temperature home page (Tank).
- Press \downarrow to interrupt the disinfection.

8.3.3 Heat source settings

Backup heater

Backup heater operation mode: defines when backup heater operation is disabled or only allowed during domestic hot water operation. This setting is only overruled when backup heating is required during defrost operation or malfunctioning of the outdoor unit (when [A.5.1.2] is enabled).

#	Code	Description
[A.5.1.1]	[4-00]	Backup heater operation: <ul style="list-style-type: none"> 0: Disabled 1 (default): Enabled
N/A	[5-00]	Is backup heater operation allowed above equilibrium temperature during space heating operation? <ul style="list-style-type: none"> 1: NOT allowed (default) 0: Allowed
[A.5.1.4]	[5-01]	Equilibrium temperature. Outdoor temperature below which operation of the backup heater is allowed. Range: -15°C~35°C (default: 0°C) (step: 1°C)

i INFORMATION

If backup heater operation during space heating needs to be limited but can be allowed for domestic hot water operation, then put [4-00] on 1, [5-00] on 1, and [5-01] on -15°C.

Auto emergency

When the heat pump fails to operate the backup heater can serve as an emergency heater and either automatically or non-automatically take over the heat load. When auto emergency is set to Automatic and a heat pump failure occurs, the backup heater will automatically take over the heat load. When a heat pump failure occurs and auto emergency is set to Manual the domestic hot water and space

heating operations will stop and need to be recovered manually. The user interface will then ask you to confirm whether the backup heater can take over the heat load or not. When the heat pump fails, $\text{\textcircled{i}}$ will appear on the user interface. If the house is unattended for longer periods, we recommend that setting [A.5.1.2] Emergency shall be set to Automatic.

#	Code	Description
[A.5.1.2]	N/A	Defines whether in an emergency situation the backup heater is allowed to automatically take over the entire heat load or whether manual confirmation is required. <ul style="list-style-type: none"> 0: Manual (default) 1: Automatic

i INFORMATION

The auto emergency setting can be set in the menu structure of the user interface only.

i INFORMATION

If a heat pump failure occurs and [A.5.1.2] is set to Manual, the room frost protection function, the underfloor heating screed dryout function, and the water pipe antifreeze function will remain active even if the user does NOT confirm emergency operation.

Bottom plate heater

Applies only to installation with an outdoor unit ERHQ and the option bottom plate heater kit is installed.

- [F-02] Bottom plate heater ON temperature: defines the outdoor temperature below which the bottom plate heater will be activated by indoor unit in order to prevent ice build-up in the bottom plate of the outdoor unit at lower outdoor temperatures.
- [F-03] Bottom plate heater hysteresis: defines the temperature difference between bottom plate heater ON temperature and the bottom plate heater OFF temperature.

Bottom plate heater

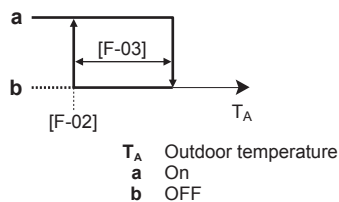

! CAUTION

The bottom plate heater is controlled via EKRP1HB.

#	Code	Description
N/A	[F-02]	Bottom plate heater ON temperature: 3°C~10°C (default: 3°C)
N/A	[F-03]	Hysteresis: 2°C~5°C (default: 5°C)

i INFORMATION

Dependent from setting [F-04] contact Y2 located on digital I/O PCB (EKRP1HB) controls the option bottom plate heater. See illustration below for the schematic location of this contact. For complete upwiring, see "14.6 Wiring diagram" on page 84.

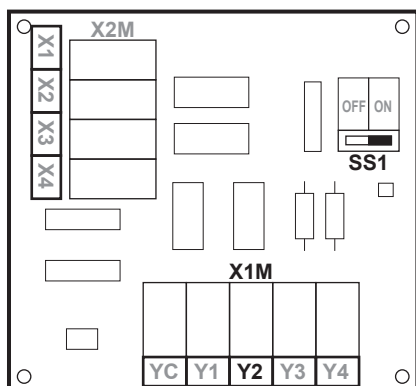

8.3.4 System settings

Priorities

#	Code	Description
N/A	[5-02]	Space heating priority. Defines whether backup heater will assist the heat pump during domestic hot water operation. Consequence: Shorter tank heating operation time and shorter interruption of the space heating cycle. This setting MUST always be 1. [5-01] Equilibrium temperature and [5-03] Space heating priority temperature are related to backup heater. So, you must set [5-03] equal or a few degrees higher than [5-01]. If the backup heater operation is limited ([4-00]=0) and the outdoor temperature is lower than setting [5-03], the domestic hot water will not be heated with the backup heater.
N/A	[5-03]	Space heating priority temperature. Defines the outdoor temperature which below the backup heater will assist during domestic hot water heating.

Auto-restart

When power returns after a power supply failure, the auto restart function reapplies the remote controller settings at the time of the power failure. Therefore, it is recommended to always enable the function.

If the preferential kWh rate power supply is of the type that power supply is interrupted, always enable the auto restart function. Continuous indoor unit control can be guaranteed independent of the preferential kWh rate power supply status, by connecting the indoor unit to a normal kWh rate power supply.

#	Code	Description
[A.6.1]	[3-00]	Is the auto restart function of the unit allowed? <ul style="list-style-type: none"> ▪ 0: No ▪ 1 (default): Yes

Preferential kWh rate power supply

#	Code	Description
[A.2.1.6]	[D-01]	Connection to a preferential kWh rate power supply: <ul style="list-style-type: none"> ▪ 0 (default): The outdoor unit is connected to a normal power supply. ▪ 1: The outdoor unit is connected to a preferential kWh rate power supply. When the preferential kWh rate signal is sent by the electricity company, the contact will open and the unit will go in forced off mode. When the signal is released again, the voltage-free contact will close and the unit will restart operation. Therefore, always enable the auto restart function. ▪ 2: The outdoor unit is connected to a preferential kWh rate power supply. When the preferential kWh rate signal is sent by the electricity company, the contact will close and the unit will go in forced off mode. When the signal is released again, the voltage-free contact will open and the unit will restart operation. Therefore, always enable the auto restart function.
[A.6.2.1]	[D-00]	Which heaters are allowed to operate during preferential kWh rate power supply? <ul style="list-style-type: none"> ▪ 0 (default): None ▪ 1: N/A ▪ 2: Backup heater only ▪ 3: N/A <p>See table below.</p> <p>Setting 2 is only meaningful if the preferential kWh rate power supply is of type 1 or indoor unit is connected to a normal kWh rate power supply (via X2M/30-31) and the backup heater is NOT connected to the preferential kWh rate power supply.</p>

Do NOT use 1 or 3.

[D-00]	Backup heater	Compressor
0 (default)	Forced OFF	Forced OFF
2	Allowed	

Power saving function



INFORMATION

Only applicable for ERLQ004~008CAV3.

Defines whether the outdoor unit power supply can be interrupted (internally by indoor unit control) during stand-still conditions (no space heating nor domestic hot water demand). The final decision to allow power interruption of the outdoor unit during standstill depends on the ambient temperature, compressor conditions and minimum internal timers.

To enable the power saving function setting, [E-08] needs to be enabled on the user interface in combination with the removal of the power saving connector at the outdoor unit.

8 Configuration



NOTICE

The power saving connector at the outdoor unit shall only be removed when the main power supply to the application is switched OFF.

In case of ERLQ004~008CAV3

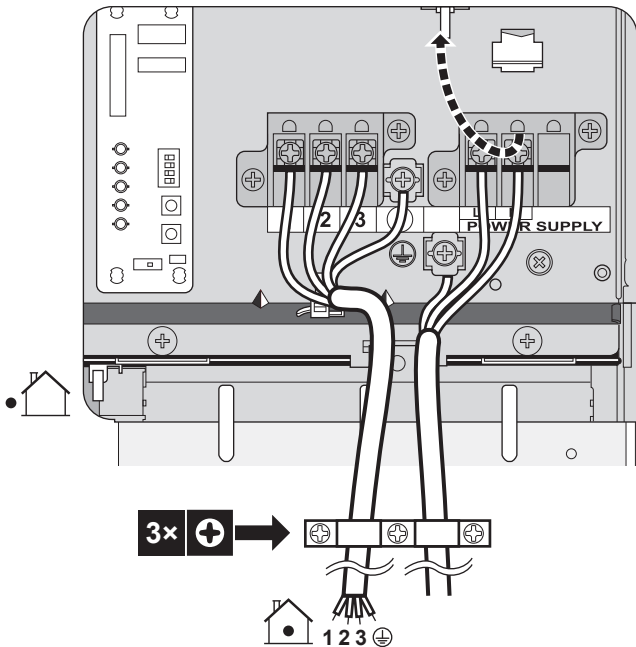

#	Code	Description
N/A	[E-08]	Power saving function for outdoor unit: <ul style="list-style-type: none"> 0: Disabled 1 (default): Enabled

In case of ERHQ011~016BAV3, ERHQ011~016BAW1, ERLQ011~016CAV3, and ERLQ011~016CAW1

Do NOT change the default setting.

#	Code	Description
N/A	[E-08]	Power saving function for outdoor unit: <ul style="list-style-type: none"> 0 (default): Disabled 1: Enabled

Power consumption control

Only applicable for EHVZ04+08. See "[5 Application guidelines](#)" on [page 10](#) for detailed information about this functionality.

Pwr consumpt. control

#	Code	Description
[A.6.3.1]	[4-08]	Mode: <ul style="list-style-type: none"> 0 (No limitation)(default): Disabled. 1 (Continuous): Enabled: You can set one power limitation value (in A or kW) to which the system power consumption will be limited for all the time. 2 (Digital inputs): Enabled: You can set up to four different power limitation values (in A or kW) to which the system power consumption will be limited when the corresponding digital input asks.

#	Code	Description
[A.6.3.2]	[4-09]	Type: <ul style="list-style-type: none"> 0 (Current): The limitation values are set in A. 1 (Power)(default): The limitation values are set in kW.
[A.6.3.3]	[5-05]	Value: Only applicable in case of full time power limitation mode. 0 A~50 A, step: 1 A (default: 50 A)
[A.6.3.4]	[5-09]	Value: Only applicable in case of full time power limitation mode. 0 kW~20 kW, step: 0.5 kW (default: 20 kW)
Amp. limits for DI: Only applicable in case of power limitation mode based on digital inputs and based on current values.		
[A.6.3.5.1]	[5-05]	Limit DI1 0 A~50 A, step: 1 A (default: 50 A)
[A.6.3.5.2]	[5-06]	Limit DI2 0 A~50 A, step: 1 A (default: 50 A)
[A.6.3.5.3]	[5-07]	Limit DI3 0 A~50 A, step: 1 A (default: 50 A)
[A.6.3.5.4]	[5-08]	Limit DI4 0 A~50 A, step: 1 A (default: 50 A)
kW limits for DI: Only applicable in case of power limitation mode based on digital inputs and based on power values.		
[A.6.3.6.1]	[5-09]	Limit DI1 0 kW~20 kW, step: 0.5 kW (default: 20 kW)
[A.6.3.6.2]	[5-0A]	Limit DI2 0 kW~20 kW, step: 0.5 kW (default: 20 kW)
[A.6.3.6.3]	[5-0B]	Limit DI3 0 kW~20 kW, step: 0.5 kW (default: 20 kW)
[A.6.3.6.4]	[5-0C]	Limit DI4 0 kW~20 kW, step: 0.5 kW (default: 20 kW)
[A.6.3.7]	[4-01]	Priority: Not applicable.

Average timer

The average timer corrects the influence of ambient temperature variations. The weather-dependent set point calculation is done on the average outdoor temperature.

The outdoor temperature is averaged over the selected time period.

#	Code	Description
[A.6.4]	[1-0A]	Outdoor average timer: <ul style="list-style-type: none"> 0: No averaging (default) 1: 12 hours 2: 24 hours 3: 48 hours 4: 72 hours



INFORMATION

If the power saving function is activated (see [E-08]), the average outdoor temperature calculation is only possible in case the external outdoor temperature sensor is used. See "[5.6 Setting up an external temperature sensor](#)" on [page 15](#).

Offset temperature external outdoor ambient sensor



Only applicable in case of an external outdoor ambient sensor is installed and configured.

You can calibrate the external outdoor ambient temperature sensor. It is possible to give an offset to the thermistor value. The setting can be used to compensate for situations where the external outdoor ambient sensor cannot be installed on the ideal installation location (see installation).

#	Code	Description
[A.6.5]	[2-0B]	-5°C~5°C, step: 0.5°C (default: 0°C)

Forced defrost

You can manually start a defrost operation.

The decision to execute the manual defrost operation is made by the outdoor unit and depends on ambient and heat exchanger conditions. When the outdoor unit accepted the forced defrost operation,  will be displayed on the user interface. If  is NOT displayed within 6 minutes after forced defrost operation was enabled, the outdoor unit ignored the forced defrost request.

#	Code	Description
[A.6.6]	N/A	Do you want to start a defrost operation?

Pump operation

When the pump operation function is disabled the pump will stop if the outdoor temperature is higher than the value set by [4-02]. When the pump operation is enabled, the pump operation is possible at all outdoor temperatures.

#	Code	Description
N/A	[F-00]	Pump operation: <ul style="list-style-type: none"> 0 (default): Disabled if outdoor temperature is higher than [4-02]. 1: Possible at all outdoor temperatures.

Pump operation during flow abnormality [F-09] defines whether the pump stops at flow abnormality or allow to continue operation when flow abnormality occurs. This functionality is only valid in specific conditions where it is preferable to keep the pump active when $T_a < 4^\circ\text{C}$ (pump will be activated for 10 minutes and deactivated after 10 minutes). Daikin shall NOT be held liable for any damage resulting this functionality.

#	Code	Description
N/A	[F-09]	Pump continue operation when flow abnormality: <ul style="list-style-type: none"> 0 (default): Pump will be deactivated. 1: Pump will be activated when $T_a < 4^\circ\text{C}$ (10 minutes ON – 10 minutes OFF)

Pump speed limitation

Pump speed limitation main zone [9-0E] and pump speed limitation additional zone [9-0D] define the maximum pump speed. In normal conditions, the default setting should NOT be modified. The pump speed limitation will be overruled when the flow rate is in the range of the minimum flow (error 7H).

#	Code	Description
N/A	[9-0E]	Pump speed limitation main zone <ul style="list-style-type: none"> 0: No limitation. 1~4: General limitation. There is limitation in all conditions. The required delta T control and comfort are NOT guaranteed. 5~8 (default: 6): Limitation when no actuators. When there is no heating output, the pump speed limitation is applicable. When there is heating output, the pump speed is only determined by delta T in relation to the required capacity. With this limitation range, delta T is possible and the comfort is guaranteed.
N/A	[9-0D]	Pump speed limitation additional zone <ul style="list-style-type: none"> 0: No limitation. 1~4: General limitation. There is limitation in all conditions. The required delta T control and comfort are NOT guaranteed. 5~8 (default: 6): Limitation when no actuators. When there is no heating output, the pump speed limitation is applicable. When there is heating output, the pump speed is only determined by delta T in relation to the required capacity. With this limitation range, delta T is possible and the comfort is guaranteed.

8 Configuration

8.4 Menu structure: Overview user settings

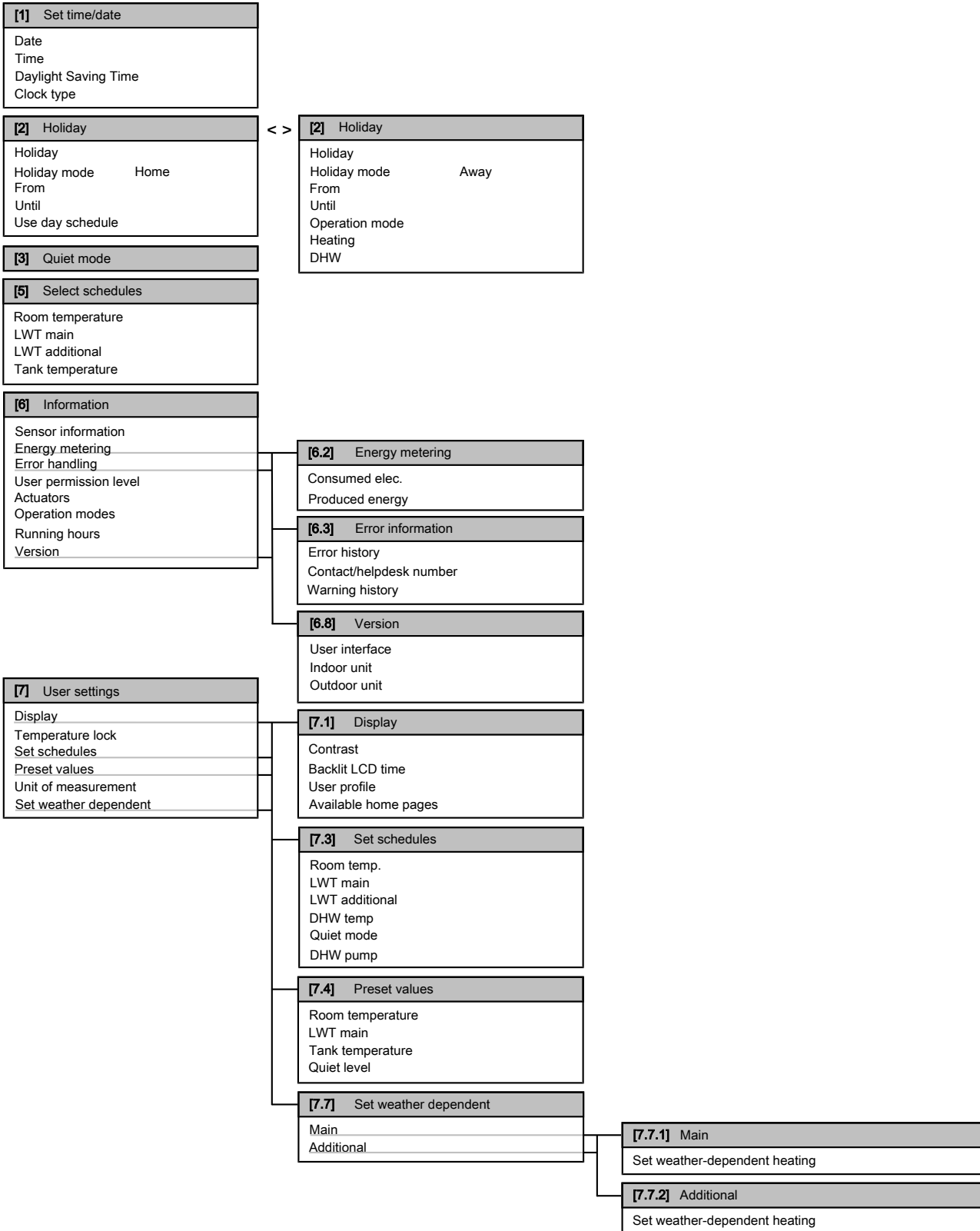



INFORMATION

Depending on the selected installer settings, settings will be visible/invisible.

8.5 Menu structure: Overview installer settings

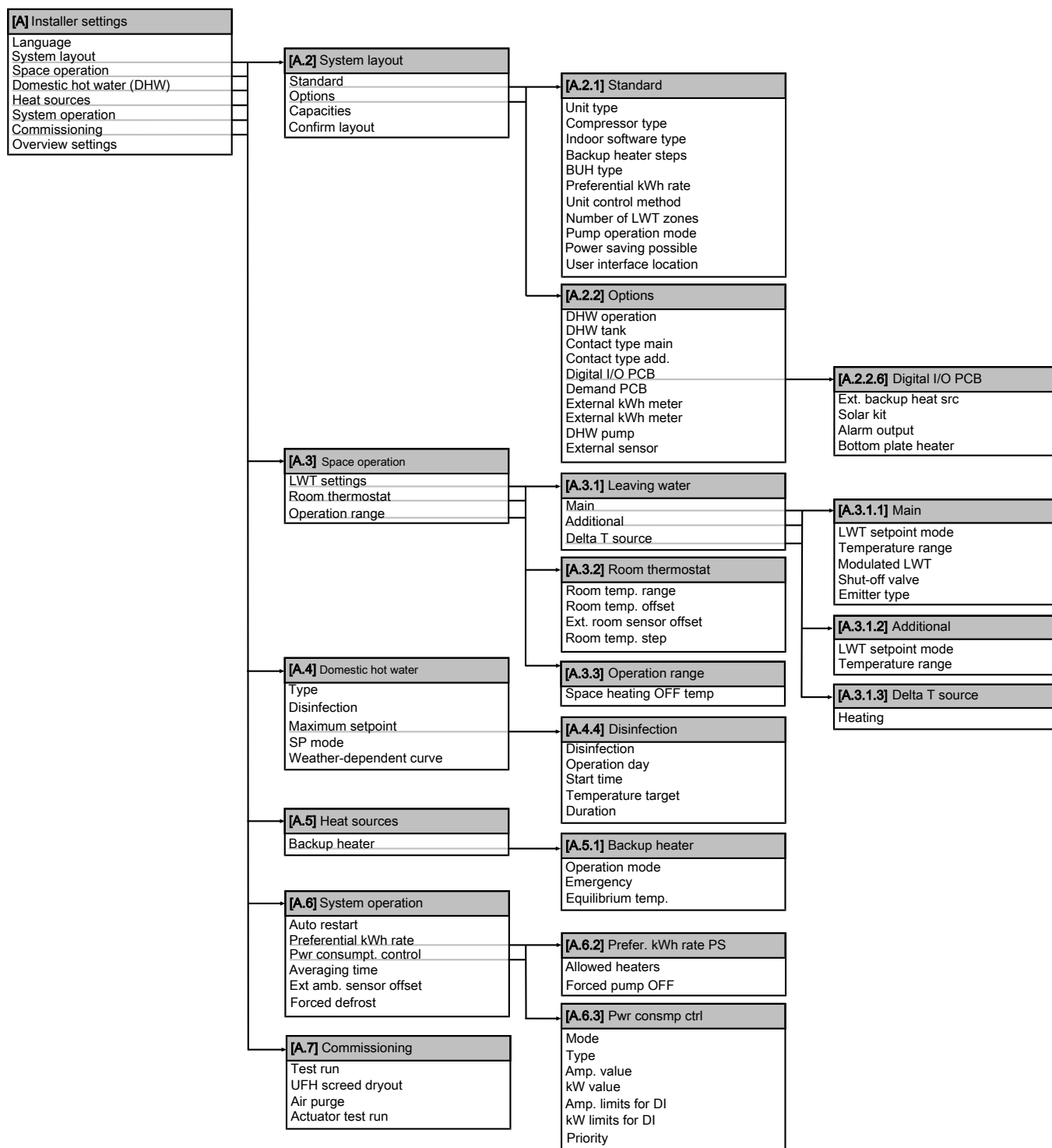

INFORMATION

Depending on the selected installer settings, settings will be visible/invisible.

9 Commissioning

9 Commissioning

9.1 Overview: Commissioning

This chapter describes what you have to do and know to commission the system after it is configured.

Typical workflow

Commissioning typically consists of the following stages:

- 1 Checking the "Checklist before commissioning".
- 2 Performing an air purge.
- 3 Performing a test run for the system.
- 4 If necessary, performing a test run for one or more actuators.
- 5 If necessary, performing an underfloor heating screed dryout.

9.2 Precautions when commissioning



INFORMATION

During the first running period of the unit, the required power may be higher than stated on the nameplate of the unit. This phenomenon is caused by the compressor, that needs a continuous run time of 50 hours before reaching smooth operation and stable power consumption.



NOTICE

Before starting up the system, the unit **MUST** be energised for at least 6 hours. The crankcase heater needs to heat up the compressor oil to avoid oil shortage and compressor breakdown during startup.



NOTICE

NEVER operate the unit without thermistors and/or pressure sensors/switches. Burning of the compressor might result.



NOTICE

Do **NOT** operate the unit until the refrigerant piping is complete (when operated this way, the compressor will break).

9.3 Checklist before commissioning

Do **NOT** operate the system before the following checks are OK:

<input type="checkbox"/>	You read the complete installation instructions, as described in the installer reference guide .
<input type="checkbox"/>	The indoor unit is properly mounted.
<input type="checkbox"/>	The outdoor unit is properly mounted.
<input type="checkbox"/>	The following field wiring has been carried out according to this document and the applicable legislation: <ul style="list-style-type: none"> ▪ Between the local supply panel and the outdoor unit ▪ Between indoor unit and outdoor unit ▪ Between the local supply panel and the indoor unit ▪ Between the indoor unit and the valves (if applicable) ▪ Between the indoor unit and the room thermostat (if applicable)
<input type="checkbox"/>	There are NO missing phases or reversed phases .
<input type="checkbox"/>	The system is properly earthed and the earth terminals are tightened.

<input type="checkbox"/>	The fuses or locally installed protection devices are installed according to this document, and have not been bypassed.
<input type="checkbox"/>	The power supply voltage matches the voltage on the identification label of the unit.
<input type="checkbox"/>	There are NO loose connections or damaged electrical components in the switch box.
<input type="checkbox"/>	There are NO damaged components or squeezed pipes on the inside of the indoor and outdoor units.
<input type="checkbox"/>	Backup heater circuit breaker F1B on the switch box is turned ON.
<input type="checkbox"/>	There are NO refrigerant leaks .
<input type="checkbox"/>	The refrigerant pipes (gas and liquid) are thermally insulated.
<input type="checkbox"/>	The correct pipe size is installed and the pipes are properly insulated.
<input type="checkbox"/>	There is NO water leak inside the indoor unit.
<input type="checkbox"/>	The shut-off valves are properly installed and fully open.
<input type="checkbox"/>	The stop valves (gas and liquid) on the outdoor unit are fully open.
<input type="checkbox"/>	The air purge valve is open (at least 2 turns).
<input type="checkbox"/>	The pressure relief valve purges water when opened.
<input type="checkbox"/>	The minimum water volume is guaranteed in all conditions. See "To check the water volume" in "6.4 Preparing water piping" on page 17 .
<input type="checkbox"/>	The safety thermostat is connected.



INFORMATION

The software is equipped with an "installer-on-site" mode ([4-0E]), that disables automatic operation by the unit. At first installation, setting [4-0E] is by default set to "1", meaning automatic operation is disabled. All protective functions are then disabled too. To enable automatic operation and the protective functions, set [4-0E] to "0".

12 hours after the first power-on, the unit will automatically set [4-0E] to "0", ending "installer-on-site" mode and enabling the protective functions. If – after first installation – the installer returns to the site, the installer has to set [4-0E] to "1" manually.

9.4 Checklist during commissioning

<input type="checkbox"/>	The minimum flow rate during backup heater/defrost operation is guaranteed in all conditions. See "To check the water volume and flow rate" in "6.4 Preparing water piping" on page 17 .
<input type="checkbox"/>	To perform an air purge .
<input type="checkbox"/>	To perform a test run .
<input type="checkbox"/>	To perform an actuator test run .
<input type="checkbox"/>	Underfloor screed dryout function The underfloor screed dryout function is started (if necessary).

9.4.1 To check the minimum flow rate

Recommended procedure for the additional zone

- 1 Confirm according to the hydraulic configuration which space heating loops can be closed due to mechanical, electronic, or other valves.
- 2 Close all space heating loops that can be closed (see previous step).
- 3 Start the pump test run operation (see "9.4.4 To perform an actuator test run" on page 62).
- 4 Go to [6.1.8]: > Information > Sensor information > Flow rate to check the flow rate. During pump test run operation, the unit can operate below this minimum required flow rate that is needed during defrost/backup heater operation.

Bypass valve foreseen?	
Yes	No
Modify the bypass valve setting to reach the minimum required flow rate + 2 l/min	In case the actual flow rate is below the minimum flow rate (required during defrost/backup heater operation), modifications at hydraulic configuration are required. Increase the space heating loops that can NOT be closed or install a pressure controlled bypass valve.

Recommended procedure for the main zone

- 5 Confirm according to the hydraulic configuration which space heating loops can be closed due to mechanical, electronic, or other valves.
- 6 Close all space heating loops that can be closed (see previous step).
- 7 Create a thermo request on the main zone only.
- 8 Wait 1 minute until the unit is stabilized.
- 9 If the additional pump is still assisting (the green LED on the right hand sided pump is ON), increase the flow until the additional pump is NOT assisting anymore (LED is OFF).
- 10 Go to [6.1.8]: > Information > Sensor information > Flow rate to check the flow rate.

Bypass valve foreseen?	
Yes	No
Modify the bypass valve setting to reach the minimum required flow rate + 2 l/min	In case the actual flow rate is below the minimum flow rate (required during defrost/backup heater operation), modifications at hydraulic configuration are required. Increase the space heating loops that can NOT be closed or install a pressure controlled bypass valve.

Minimum required flow rate during defrost/backup heater operation	
04+08 models	12 l/min
16 model	15 l/min

9.4.2 Air purge function

When commissioning and installing the unit, it is very important to remove all air in the water circuit. When the air purge function is running, the pumps operate without actual operation of the unit and the removal of air in the water circuit will start.



NOTICE

Before starting the air purge, open the safety valve and check if the circuit is sufficiently filled with water. Only if water escapes the valve after opening it, you can start the air purge procedure.

There are 2 modes for purging air:

- Manually: the unit will operate with a custom pump speed and in a custom position of the 3-way valve (space heating/domestic hot water). The custom position of the 3-way valve is a helpful feature to remove all air from the water circuit in the space heating or the domestic hot water heating mode. The operation speed of the pump (slow or quick) can also be set.
- Automatic: the unit automatically changes the pump speed and the position of the 3-way valve (space heating/domestic hot water) between the space heating or the domestic hot water heating mode.



INFORMATION

For both manual and automatic air purge, 1 temperature zone is purged with each air purge start. To purge the other temperature zone, you have to restart the air purge function. When performing an air purge for the first time, the main temperature zone will be purged.

Typical workflow

Purging the air from the system should consist of:

- 1 Performing a manual air purge for both zones
- 2 Performing an automatic air purge for both zones



INFORMATION

Start by performing a manual air purge on both zones. When almost all the air is removed, perform an automatic air purge on both zones. If necessary, repeat performing the automatic air purge until you are sure that all air is removed from the system. During air purge function, pump speed limitation [9-0D] is NOT applicable.

Make sure the user interface shows the home screens and that the space heating and domestic hot water demands are turned off.

To perform a manual air purge



INFORMATION

When purging the main zone, make sure the setpoint for the main zone is at least 5°C higher than the actual water temperature inside the unit.

Prerequisite: Make sure the user interface shows the home screens and that the space heating and domestic hot water demands are turned off.

- 1 Set the user permission level to Installer. See "To set the user permission level to Installer" on page 40.
- 2 Set the air purge mode: go to [A.7.3.1] > Installer settings > Commissioning > Air purge > Type.
- 3 Select Manual and press .
- 4 Go to [A.7.3.4] > Installer settings > Commissioning > Air purge > Start air purge and press to start the air purge function.

Result: The manual air purge starts and the following screen appears.

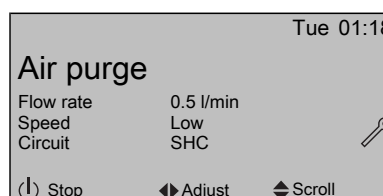

9 Commissioning



- 5 Use the ◀ and ▶ buttons to scroll to Speed.
- 6 Use the ▲ and ▼ buttons to set the desired pump speed.
Result: Low
Result: High
- 7 If applicable, set the desired position of the 3-way valve (space heating/domestic hot water). Use the ◀ and ▶ buttons to scroll to Circuit.
- 8 Use the ▲ and ▼ buttons to set the desired position of the 3-way valve (space heating/domestic hot water).
Result: SHC
Result: Tank

To perform an automatic air purge

INFORMATION

When purging the main zone, make sure the setpoint for the main zone is at least 5°C higher than the actual water temperature inside the unit.

Prerequisite: Make sure the user interface shows the home screens and that the space heating and domestic hot water demands are turned off.

- 1 Set the user permission level to Installer. See ["To set the user permission level to Installer" on page 40](#).
- 2 Set the air purge mode: go to [A.7.3.1]  > Installer settings > Commissioning > Air purge > Type.
- 3 Select Automatic and press **OK**.
- 4 Go to [A.7.3.4]  > Installer settings > Commissioning > Air purge > Start air purge and press **OK** to start the air purge function.
Result: Air purging will start and the following screen will be shown.

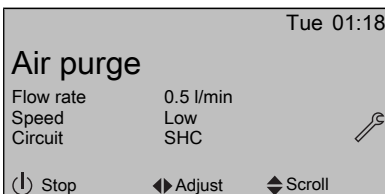

The automatic air purge function stops automatically after 30 minutes, then the installer has to restart the automatic air purge function for the second temperature zone. This function will also stop automatically after 30 minutes

To interrupt air purge

- 1 Press  and press **OK** to confirm the interruption of the air purge function. When you restart the air purge function, the other zone will be air purged.

9.4.3 To perform a test run

INFORMATION

The test run only applies to the additional temperature zone.

Prerequisite: Make sure the user interface shows the home screens and that the space heating and domestic hot water demands are turned off.

- 1 Set the user permission level to Installer. See ["To set the user permission level to Installer" on page 40](#).
- 2 Go to [A.7.1]:  > Installer settings > Commissioning > Test run.
- 3 Select a test and press **OK**. **Example:** Heating.
- 4 Select OK and press **OK**.

Result: The test run starts. It stops automatically when done (±30 min). To stop it manually, press , select OK and press **OK**.

INFORMATION

If 2 user interfaces are present, you can start a test run from both user interfaces.

- The user interface used to start the test run displays a status screen.
- The other user interface displays a "busy" screen. You cannot use the user interface as long as the "busy" screen is shown.

If the installation of the unit has been done correctly, the unit will start up during test operation. During the test mode, the correct operation of the unit can be checked by monitoring leaving water temperature (heating mode) and tank temperature (domestic hot water mode).

To monitor the temperature, go to [A.6] and select the information you want to check.

9.4.4 To perform an actuator test run

Purpose of the actuator test run is to confirm the operation of the different actuators (e.g., when you select pump operation, a test run of the pump will start).

Prerequisite: Make sure the user interface shows the home screens and that the space heating and domestic hot water demands are turned off.

- 1 Set the user permission level to Installer. See ["To set the user permission level to Installer" on page 40](#).
- 2 Make sure the room temperature control, the leaving water temperature control and the domestic hot water control are turned OFF via the user interface.
- 3 Go to [A.7.4]:  > Installer settings > Commissioning > Actuator test run.
- 4 Select an actuator and press **OK**. **Example:** Pump.
- 5 Select OK and press **OK**.

Result: The actuator test run starts. It automatically stops when finished. To stop it manually, press , select OK and press **OK**.

Possible actuator test runs

- Backup heater (step 1) test
- Pump test (only the pump of the additional temperature zone)

INFORMATION

Make sure that all air is purged before executing the test run. Also avoid disturbances in the water circuit during the test run.

- 2-way valve test
- 3-way valve test (3-way valve for switching between space heating and tank heating)
- Bottom plate heater test
- Bivalent signal test
- Alarm output test
- Heating signal test
- Quick heat-up test
- Circulation pump test

9.4.5 Underfloor heating screed dryout

This function is used for drying out the screed of an underfloor heating system very slowly during the construction of a house. It allows the installer to program and execute this program.

Make sure the user interface shows the home screens and that the space heating and domestic hot water demands are turned off.

This function can be executed without finishing the outdoor installation. In this case, the backup heater will perform the screed dryout and supply the leaving water without heat pump operation.

When no outdoor unit is installed yet, then connect the main power supply cable to the indoor unit via X2M/30 and X2M/31. See "7.9.9 To connect the main power supply" on page 36.

i INFORMATION

- If Emergency is set to Manual ([A.5.1.2]=0), and the unit is triggered to start emergency operation, the user interface will ask confirmation before starting. The underfloor heating screed dryout function is active even if the user does NOT confirm emergency operation.
- During underfloor heating screed dryout, pump speed limitation [9-0D] is NOT applicable.

! NOTICE

The installer is responsible for:

- contacting the screed manufacturer for the initial heating instructions to avoid cracking the screed,
- programming the underfloor heating screed dryout schedule according to the above instruction of the screed manufacturer,
- checking the proper functioning of the setup on a regular basis,
- selecting the correct program complying with the type of the used screed of the floor.

! NOTICE

To perform an underfloor heating screed dryout, room frost protection needs to be disabled ([2-06]=0). By default, it is enabled ([2-06]=1). However, due to the "installer-on-site" mode (see "Checklist before commissioning"), room frost protection will be automatically disabled for 12 hours after the first power-on.

If the screed dryout still needs to be performed after the first 12 hours of power-on, manually disable room frost protection by setting [2-06] to "0", and KEEP it disabled until the screed dryout has finished. Ignoring this notice will result in cracking of the screed.

! NOTICE

For the underfloor heating screed dryout to be able to start, make sure the following settings are met:

- [4-00] = 1
- [C-02] = 0
- [D-01] = 0
- [4-08] = 0
- [4-01] ≠ 1

The installer can program up to 20 steps. For each step he needs to enter:

- 1 the duration in hours, up to 72 hours,
- 2 the desired leaving water temperature.

Example:

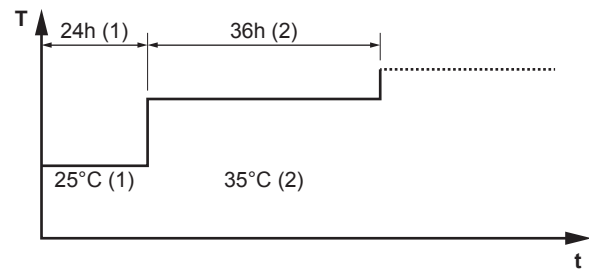

- T Desired leaving water temperature (15~55°C)
- t Duration (1~72 h)
- (1) Action step 1
- (2) Action step 2

To program an underfloor heating screed dryout schedule

- 1 Set the user permission level to Installer. See "To set the user permission level to Installer" on page 40.
- 2 Go to [A.7.2]: > Installer settings > Commissioning > UFH screed dryout > Set dryout schedule.
- 3 Use the , , , and to program the schedule.
 - Use and to scroll through the schedule.
 - Use and to adjust the selection.
 - If a time is selected, you can set the duration between 1 and 72 hours.
 - If a temperature is selected, you can set the desired leaving water temperature between 15°C and 55°C.
- 4 To add a new step, select "-h" or "-°" on an empty line and press .
- 5 To delete a step, set the duration to "-" by pressing .
- 6 Press to save the schedule.



It is important that there is no empty step in the program. The schedule will stop when a blank step is programmed OR when 20 consecutive steps have been executed.

To perform an underfloor heating screed dryout



INFORMATION

Preferential kWh rate power supply cannot be used in combination with underfloor heating screed dryout.

Prerequisite: Make sure there is ONLY 1 user interface connected to your system to perform an underfloor heating screed dryout.

Prerequisite: Make sure the user interface shows the home screens and that the space heating and domestic hot water demands are turned off.

- 1 Go to [A.7.2]: > Installer settings > Commissioning > UFH screed dryout.
- 2 Set a dryout program.
- 3 Select Start dryout and press .
- 4 Select OK and press .

Result: The underfloor heating screed dryout starts and following screen will be shown. It stops automatically when done. To stop it manually, press , select OK and press .

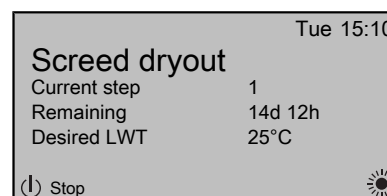

10 Hand-over to the user

To readout the status of an underfloor heating screed dryout

- 1 Press .
- 2 The current step of the program, the total remaining time, and the current desired leaving water temperature will be displayed.





INFORMATION

There is limited access to the menu structure. Only the following menus can be accessed:

- Information.
- Installer settings > Commissioning > UFH screed dryout.

To interrupt an underfloor heating screed dryout

When the program is stopped by an error, an operation switch off, or a power failure, the U3 error will be displayed on the user interface. To resolve the error codes, see "[12.4 Solving problems based on error codes](#)" on page 68. To reset the U3 error, your User permission level needs to be Installer.

- 1 Go to the underfloor heating screed dryout screen.
- 2 Press .
- 3 Press  to interrupt the program.
- 4 Select OK and press .

Result: The underfloor heating screed dryout program is stopped.

When the program is stopped due to an error, an operation switch-off, or a power failure, you can read out the underfloor heating screed dryout status.

- 5 Go to [A.7.2]:  > Installer settings > Commissioning > UFH screed dryout > Dryout status > Stopped at and followed by the last executed step.
- 6 Modify and restart the execution of the program.

10 Hand-over to the user

Once the test run is finished and the unit operates properly, please make sure the following is clear for the user:

- Fill in the installer setting table (in the operation manual) with the actual settings.
- Make sure that the user has the printed documentation and ask him/her to keep it for future reference. Inform the user that he can find the complete documentation on the url as earlier described in this manual.
- Explain the user how to properly operate the system and what to do in case of problems.
- Show the user what to do in relation to maintaining the unit.
- Explain the user about energy saving tips as described in the operation manual.

11 Maintenance and service



NOTICE

Maintenance should preferably be carried out yearly by an installer or service agent.

11.1 Overview: Maintenance and service

This chapter contains information about:

- The yearly maintenance of the outdoor unit
- The yearly maintenance of the indoor unit

11.2 Maintenance safety precautions



DANGER: RISK OF ELECTROCUTION



DANGER: RISK OF BURNING



NOTICE: Risk of electrostatic discharge

Before performing any maintenance or service work, touch a metal part of the unit in order to eliminate static electricity and to protect the PCB.

11.2.1 Opening the indoor unit



CAUTION

The front panel is heavy. Be careful NOT to jam your fingers when opening or closing the unit.

You just need to remove the front panel of the unit to gain access to most parts which need maintenance. In rare cases, you may also need to remove the switch box.

11.3 Checklist for yearly maintenance of the outdoor unit

Check the following at least once a year:

- Outdoor unit heat exchanger.

The heat exchanger of the outdoor unit can get blocked up due to dust, dirt, leaves, etc. It is recommended to clean the heat exchanger yearly. A blocked heat exchanger can lead to too low pressure or too high pressure leading to worse performance.

11.4 Checklist for yearly maintenance of the indoor unit

Check the following at least once a year:

- Water pressure
- Water filters
- Water pressure relief valve
- Relief valve hose
- Pressure relief valve of the domestic hot water tank
- Switch box
- Descaling
- Chemical disinfection
- Anode

Water pressure

Check whether the water pressure is above 1 bar. If it is lower, add water.

Water filters

Clean the water filters.



NOTICE

Handle the water filters with care. Do NOT use excessive force when you reinsert the water filters so as NOT to damage the water filters mesh.

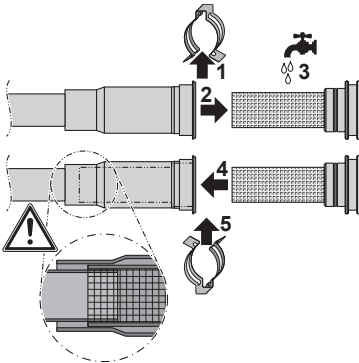

Water pressure relief valve

Open the valve and check if it operates correctly. **The water may be very hot!**

Checkpoints are:

- The water flow coming from the relief valve is high enough, no blockage of the valve or in between piping is suspected.
- Dirty water coming out of the relief valve:
 - open the valve until the discharged water does NOT contain dirt anymore
 - flush the system and install an additional water filter (a magnetic cyclone filter is preferable).

To make sure this water originates from the tank, check after a tank heat up cycle.

It is recommended to do this maintenance more frequently.

Pressure relief valve hose

Check whether the pressure relief valve hose is positioned appropriately to drain the water. See "7.8.5 To connect the pressure relief valve to the drain" on page 31.

Relief valve of the domestic hot water tank (field supply)

Open the valve and check the correct operation. **Water may be very hot!**

Checkpoints are:

- The water flow coming from the relief valve is high enough, no blockage of the valve or in between piping is suspected.
- Dirty water coming out of the relief valve:
 - open the valve until the discharged water does not contain dirt anymore
 - flush and clean the complete tank, including the piping between the relief valve and cold water inlet.

To make sure this water originates from the tank, check after a tank heat up cycle.

It is recommended to do this maintenance more frequently.

Switch box

- Carry out a thorough visual inspection of the switch box and look for obvious defects such as loose connections or defective wiring.
- Using an ohmmeter, check if contactors K1M, K2M and K3M operate correctly. All contacts of these contactors must be in open position when the power is turned OFF.



WARNING

If the internal wiring is damaged, it has to be replaced by the manufacturer, its service agent or similarly qualified persons.

Descaling

Depending on water quality and set temperature, scale can deposit on the heat exchanger inside the domestic hot water tank and can restrict heat transfer. For this reason, descaling of the heat exchanger may be required at certain intervals.

Chemical disinfection

If the applicable legislation requires a chemical disinfection in specific situations, involving the domestic hot water tank, please be aware that the domestic hot water tank is a stainless steel cylinder containing an aluminium anode. We recommend to use a non-chloride based disinfectant approved for use with water intended for human consumption.



NOTICE

When using means for descaling or chemical disinfection, it must be ensured that the water quality remains compliant with EU directive 98/83 EC.

Anode

No maintenance or replacement required.

11.4.1 To drain the domestic hot water tank

Prerequisite: Switch OFF the power supply.

Prerequisite: Turn OFF the cold water supply.

- 1 Open the front panel.
- 2 Remove the 2 screws, unhook and put the switch box aside.

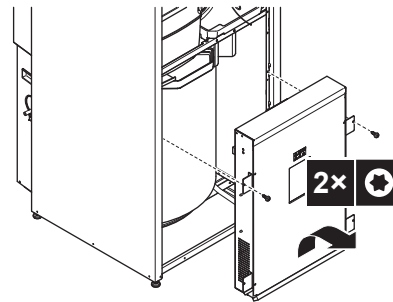

- 3 The drain hose is located at the right side of the unit. Cut the tie wraps or tape and bring the flexible drain hose forward.

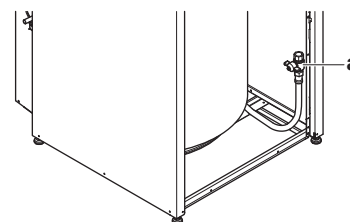

a Drain hose



INFORMATION

To drain the tank, all the hot water tapping points need to be opened to allow air to enter the system.

- 4 Open the drain valve.

12 Troubleshooting

12.1 Overview: Troubleshooting

This chapter describes what you have to do in case of problems.

It contains information about:

- Solving problems based on symptoms
- Solving problems based on error codes

12 Troubleshooting

Before troubleshooting

Carry out a thorough visual inspection of the unit and look for obvious defects such as loose connections or defective wiring.

12.2 Precautions when troubleshooting



WARNING

- When carrying out an inspection on the switch box of the unit, always make sure that the unit is disconnected from the mains. Turn off the respective circuit breaker.
- When a safety device was activated, stop the unit and find out why the safety device was activated before resetting it. NEVER bridge safety devices or change their values to a value other than the factory default setting. If you are unable to find the cause of the problem, call your dealer.



DANGER: RISK OF ELECTROCUTION



WARNING

Prevent hazard due to the inadvertent resetting of the thermal cut-out: this appliance must NOT be supplied through an external switching device, such as a timer, or connected to a circuit that is regularly turned ON and OFF by the utility.



DANGER: RISK OF BURNING

12.3 Solving problems based on symptoms

12.3.1 Symptom: The unit is NOT heating as expected

Possible causes	Corrective action
The temperature setting is NOT correct	Check the temperature setting on the remote controller. Refer to the operation manual.
The water flow is too low	<p>Check and make sure that:</p> <ul style="list-style-type: none"> All shut-off valves of the water circuit are completely open. The water filters are clean. Clean if necessary. There is no air in the system. Purge air if necessary. You can purge air manually (see "To perform a manual air purge" on page 61) or use the automatic air purge function (see "To perform an automatic air purge" on page 62). The water pressure is >1 bar. The expansion vessel is NOT broken. The resistance in the water circuit is NOT too high for the pump (see "14.9 ESP curve" on page 116). <p>If the problem persists after you have conducted all of the above checks, contact your dealer. In some cases, it is normal that the unit decides to use a low water flow.</p>

Possible causes	Corrective action
The water volume in the installation is too low	Make sure that the water volume in the installation is above the minimum required value (see "6.4.3 To check the water volume and flow rate" on page 18).

12.3.2 Symptom: The compressor does NOT start (space heating or domestic water heating)

Possible causes	Corrective action
The unit must start up out of its operation range (the water temperature is too low)	<p>If the water temperature is too low, the unit uses the backup heater to reach the minimum water temperature first (15°C).</p> <p>Check and make sure that:</p> <ul style="list-style-type: none"> The power supply to the backup heater is correctly wired. The backup heater thermal protector is NOT activated. The backup heater contactor is NOT broken. <p>If the problem persists after you have conducted all of the above checks, contact your dealer.</p>
The preferential kWh rate power supply settings and electrical connections do NOT match	This should match with the connections as explained in "6.5 Preparing electrical wiring" on page 20 and "7.9.9 To connect the main power supply" on page 36.
The preferential kWh rate signal was sent by the electricity company	Wait for the power to return (2 hours max.).

12.3.3 Symptom: The pump is making noise (cavitation)

Possible causes	Corrective action
There is air in the system	Purge air manually on both zones (see "To perform a manual air purge" on page 61) or use the automatic air purge function on both zones (see "To perform an automatic air purge" on page 62).
The water pressure at the pump inlet is too low	<p>Check and make sure that:</p> <ul style="list-style-type: none"> The water pressure is >1 bar. The manometer is not broken. The expansion vessel is NOT broken. The pre-pressure setting of the expansion vessel is correct (see "6.4.4 Changing the pre-pressure of the expansion vessel" on page 19).

12.3.4 Symptom: The pressure relief valve opens

Possible causes	Corrective action
The expansion vessel is broken	Replace the expansion vessel.

Possible causes	Corrective action
The water volume in the installation is too high	Make sure that the water volume in the installation is below the maximum allowed value (see "6.4.3 To check the water volume and flow rate" on page 18 and "6.4.4 Changing the pre-pressure of the expansion vessel" on page 19).
The water circuit head is too high	The water circuit head is the difference in height between the indoor unit and the highest point of the water circuit. If the indoor unit is located at the highest point of the installation, the installation height is considered 0 m. The maximum water circuit head is 10 m. Check the installation requirements.

12.3.5 Symptom: The water pressure relief valve leaks

Possible causes	Corrective action
Dirt is blocking the water pressure relief valve outlet	Check whether the pressure relief valve works correctly by turning the red knob on the valve counterclockwise: <ul style="list-style-type: none"> ▪ If you do NOT hear a clacking sound, contact your dealer. ▪ If the water keeps running out of the unit, close both the water inlet and outlet shut-off valves first and then contact your dealer.

12.3.6 Symptom: The space is NOT sufficiently heated at low outdoor temperatures

Possible causes	Corrective action
The backup heater operation is not activated	Check and make sure that: <ul style="list-style-type: none"> ▪ The backup heater operation mode is enabled. Go to: <ul style="list-style-type: none"> ▪ [A.5.1.1] > Installer settings > Heat sources > Backup heater > Operation mode [4-00] ▪ The thermal protector of the backup heater has not been activated. If it has, check: <ul style="list-style-type: none"> ▪ The water pressure ▪ Whether there is air in the system ▪ The air purge operation <p>Press the reset button in the switch box. See "14.4 Components" on page 79 for the location of the reset button.</p>

Possible causes	Corrective action
The backup heater equilibrium temperature has not been configured correctly	Increase the "equilibrium temperature" to activate the backup heater operation at a higher outdoor temperature. Go to: <ul style="list-style-type: none"> ▪ [A.5.1.4] > Installer settings > Heat sources > Backup heater > Equilibrium temp. OR ▪ [A.8] > Installer settings > Overview settings [5-01]
Too much heat pump capacity is used for heating domestic hot water	Check and make sure that the "space heating priority" settings have been configured appropriately: <ul style="list-style-type: none"> ▪ Make sure that the "space heating priority status" has been enabled. Go to [A.8] > Installer settings > Overview settings [5-02] ▪ Increase the "space heating priority temperature" to activate backup heater operation at a higher outdoor temperature. Go to [A.8] > Installer settings > Overview settings [5-03]

12.3.7 Symptom: The pressure at the tapping point is temporarily unusual high

Possible causes	Corrective action
Failing or blocked pressure relief valve.	<ul style="list-style-type: none"> ▪ Flush and clean the complete tank including the piping between pressure relief valve and the cold water inlet. ▪ Replace the pressure relief valve.



12.3.8 Symptom: Decoration panels are pushed away due to a swollen tank

Possible causes	Corrective action
Failing or blocked pressure relief valve.	Contact your local dealer.

12.3.9 Symptom: Tank disinfection function is NOT completed correctly (AH-error)

Possible causes	Corrective action
The disinfection function was interrupted by domestic hot water tapping	Program the start-up of the disinfection function when the coming 4 hours NO domestic hot water tapping is expected.

12 Troubleshooting

Possible causes	Corrective action
Large domestic hot water tapping happened recently before the programmed start-up of the disinfection function	When the Domestic hot water > Type > Reheat or Reheat + sched. is selected, it is recommended to program the start-up the disinfection function at least 4 hours later than the last expected large hot water tapping. This start-up can be set by installer settings (disinfection function). When the Domestic hot water > Type > Scheduled only is selected, it is recommended to program a Storage eco 3 hours before the scheduled start-up of the disinfection function to preheat the tank.
The disinfection operation was stopped manually: with the user interface displaying the DHW home page and its user permission level set to Installer, the  button was pressed during disinfection operation.	Do NOT press the  button while the disinfection function is active.

12.4 Solving problems based on error codes

When a problem happens, an error code appears on the user interface. It is important to understand the problem and to take countermeasure before resetting the error code. This should be done by a licensed installer or by your local dealer.

This chapter gives you an overview of all error codes and the content of the error code as it appears on the user interface.

For a more detailed troubleshooting guideline for each error, please see the service manual.

12.4.1 Error codes: Overview

Error codes of the indoor unit

Error code	Detailed error code	Description
A1	00	Zero cross detection problem. Power reset required. Please contact your dealer.
AA	01	Backup heater overheated. Power reset required. Please contact your dealer.
UA	00	Indoor unit, outdoor unit matching problem. Power reset required.
7H	01	Water flow problem. Auto restart.

Error code	Detailed error code	Description
7H	04	Water flow problem during domestic hot water production. Manual reset. Check the domestic hot water circuit.
7H	05	Water flow problem during heating/sampling. Manual reset. Check the space heating circuit.
7H	06	Water flow problem during defrost. Manual reset. Check the plate heat exchanger.
81	01	Mixed water thermistor abnormality. Auto reset. ¹
89	01	Heat exchanger frozen.
8H	00	Abnormal increase outlet water temperature.
8H	01	Overheating mixed water circuit. Auto reset. ¹
8H	02	Overheating mixed water circuit (thermostat). Auto reset. ¹
8F	00	Abnormal increase outlet water temperature (DHW).
C0	00	Flow sensor malfunction. Manual reset.
U3	00	Under floor heating screed dryout function not completed correctly.
81	00	Leaving water temperature sensor problem. Please contact your dealer.
C4	00	Heat exchanger temperature sensor problem. Please contact your dealer.
80	00	Returning water temperature sensor problem. Please contact your dealer.
U5	00	User interface communication problem.

¹ On the home screen of your user inter interface, the following information will be displayed:

Bi-zone kit abnormality
detection
Refer to bi-zone kit manual

Error code	Detailed error code	Description
U4	00	Indoor/outdoor unit communication problem.
EC	00	Abnormal increase tank temperature.
HC	00	Tank temperature sensor problem. Please contact your dealer.
CJ	02	Room temperature sensor problem. Please contact your dealer.
H1	00	External temperature sensor problem. Please contact your dealer.
89	02	Heat exchanger frozen.
A1	01	EEPROM reading error.
AH	00	Tank disinfection function not completed correctly.
89	03	Heat exchanger frozen.
AJ	03	Too long DHW heat-up time required.
UA	16	Extension/hydro communication problem.
UA	17	Tank type problem
UA	21	Extension/hydro mismatch problem.

INFORMATION

In case of error code AH and no interruption of the disinfection function occurred due to domestic hot water tapping, following actions are recommended:

- When the Domestic hot water > Type > Reheat or Reheat + sched. is selected, it is recommended to program the start-up of the disinfection function at least 4 hours later than the last expected large hot water tapping. This start-up can be set by installer settings (disinfection function).
- When the Domestic hot water > Type > Scheduled only is selected, it is recommended to program a Storage eco 3 hours before the scheduled start-up of the disinfection function to preheat the tank.



NOTICE

When the minimum water flow is lower than described in the table below, the unit will temporarily stop operation and the user interface will display error 7H-01. After some time, this error will reset automatically and the unit will resume operation.

Minimum required flow during heat pump operation	
04 models	6 l/min
08 models	6 l/min
16 models	10 l/min

Minimum required flow during defrost operation	
04+08 models	12 l/min
16 models	15 l/min

Minimum required flow during backup heater operation	
All models	12 l/min

If the 7H error persists, the unit will stop operation and the user interface will display an error code that needs to be reset manually. Depending on the problem, this error code is different:

Error code	Detailed error code	Description
7H	04	The water flow problems mainly occurred during domestic hot water operation. Check the domestic hot water circuit.
7H	05	The water flow problems mainly occurred during space heating operation. Check the space heating circuit.
7H	06	The water flow problems mainly occurred during defrost operation. Check the space heating circuit. Additionally, this error code might be an indication of frost damage to the plate heat exchanger. In that case, contact your local dealer.



INFORMATION

Error AJ-03 is reset automatically from the moment there is a normal tank heat-up.



INFORMATION

If the unit detects flow when the pump is not running, an external device might be causing flow, or there might be something wrong with the flow measuring devices (flow sensor).

- If the flow sensor detects flow when the pump is not running, the unit will stop operation and the user interface will display error C0-00. For the unit to resume operation, this error needs to be reset manually.

13 Disposal

13.1 Overview: Disposal

Typical workflow

Disposing of the system typically consists of the following stages:

- 1 Pumping down the system.
- 2 Dismantling the system according to the applicable legislation.
- 3 Treating the refrigerant, oil and other parts according to the applicable legislation.



INFORMATION

For more details, see the service manual.

13.2 About pump down

The unit is equipped with an automatic pump down function, with which you can collect all refrigerant from the system into the outdoor unit.

Example: To protect the environment, pump down when relocating the unit or when disposing of the unit.



NOTICE

The outdoor unit is equipped with a low pressure switch or a low pressure sensor to protect the compressor by turning it OFF. NEVER short-circuit the low pressure switch during pump down operation.

Before pumping down



NOTICE

Before you pump down, make sure the water temperature (example: by performing a heating operation) and water volume (example: by opening all heat emitters) are sufficiently high. Pump down is done in cooling mode.

13.3 To pump down

- 1 Turn ON the main power supply switch.
- 2 Make sure the liquid stop valve and the gas stop valve are open.
- 3 Press the pump down button (BS4) for at least 8 seconds. BS4 is located on the PCB in the outdoor unit (see wiring diagram).

Result: The compressor and outdoor unit fan start automatically.

- 4 Once operation stops (after 3~5 minutes), close the liquid stop valve and the gas stop valve.

Result: The pump down operation is finished. The user interface may display "L4" and the indoor pump may continue operating. This is NOT a malfunction. Even if you press the ON button on the user interface, the unit will NOT start. To restart the unit, turn OFF the main power supply switch and turn it ON again.

- 5 Turn OFF the main power supply switch.



NOTICE

Make sure to reopen both stop valves before restarting the unit.

14 Technical data

14.1 Overview: Technical data

This chapter contains information about:

- Dimensions and service space
- Centre of gravity
- Components
- Piping diagram
- Wiring diagram
- Technical specifications
- Operation range
- ESP curve

14.2 Dimensions and service space

14.2.1 Dimensions: Outdoor unit

ERHQ_V3 (dimensions in mm)

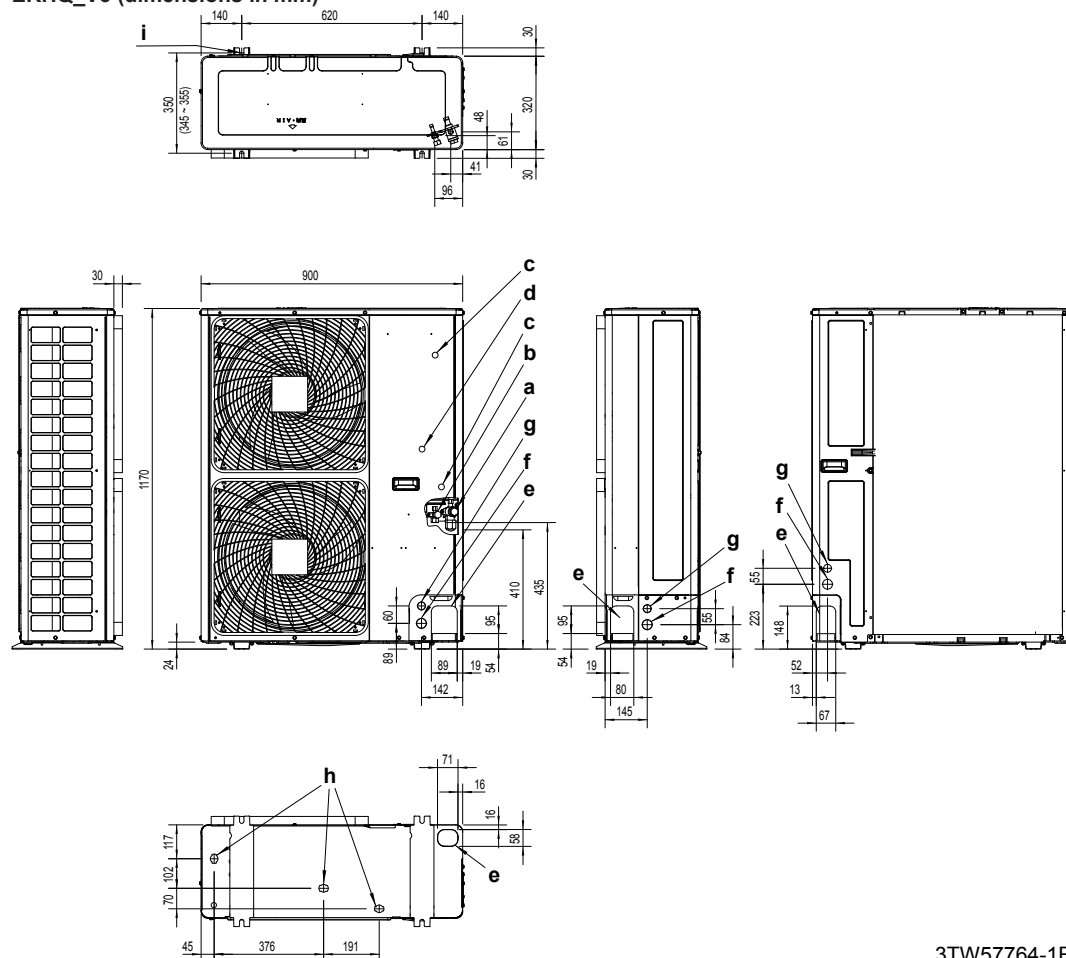

3TW57764-1B

- a Gas pipe connection (Ø15.9 flare connection)
- b Liquid pipe connection (Ø9.5 flare connection)
- c Internal service port 5/16"
- d Electronic connection and earthing terminal M5 (in the switch box)
- e Refrigerant piping intake
- f Power supply wiring intake (knockout hole Ø34)
- g Control wiring intake (knockout hole Ø27)
- h Drain hole
- i Anchor point (bolt 4× M12)

14 Technical data

ERHQ_W1 (dimensions in mm)

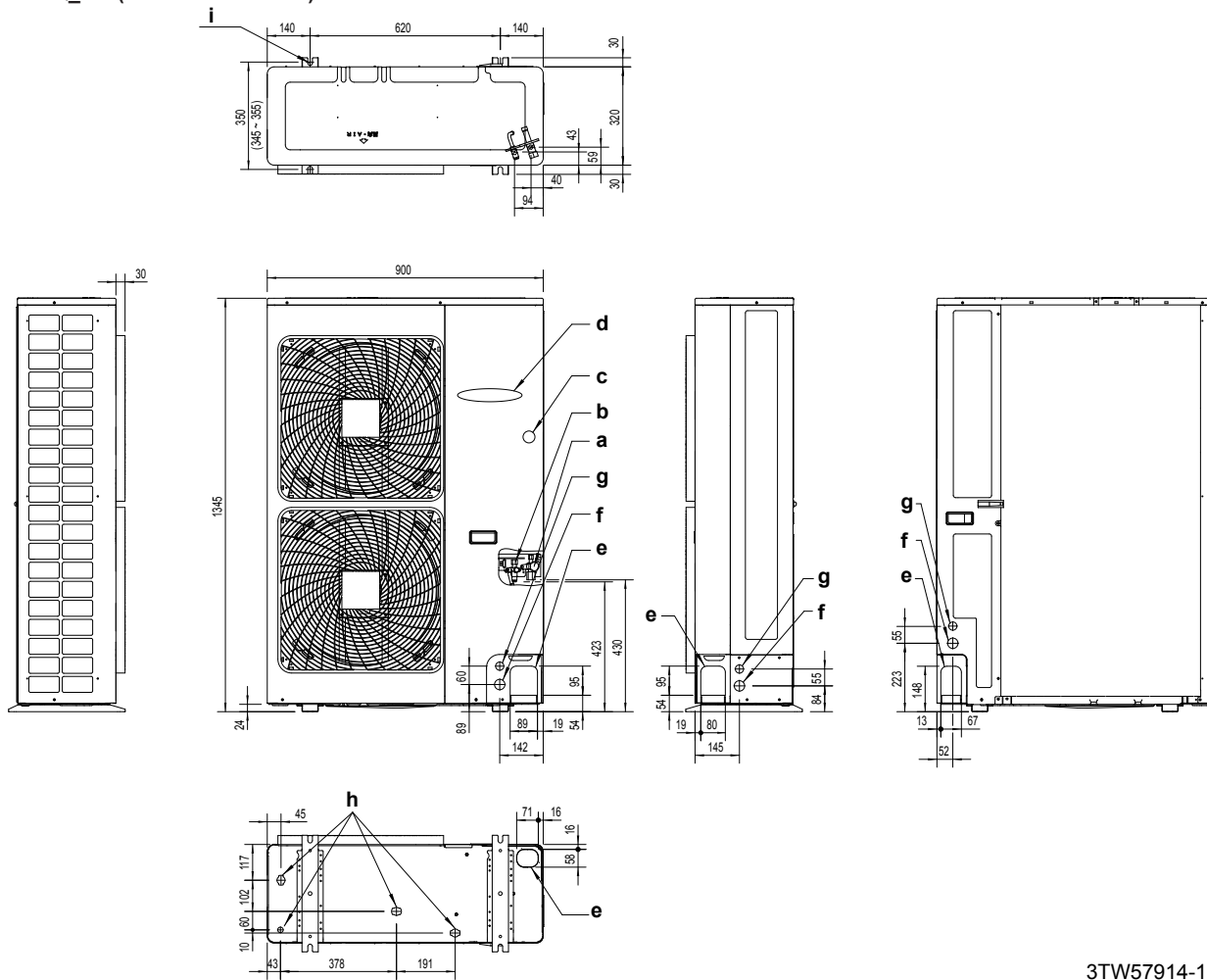

3TW57914-1

- a Gas pipe connection (Ø15.9 flare connection)
- b Liquid pipe connection (Ø9.5 flare connection)
- c Internal service port 5/16"
- d Electronic connection and earthing terminal M5 (in the switch box)
- e Refrigerant piping intake
- f Power supply wiring intake (knockout hole Ø34)
- g Control wiring intake (knockout hole Ø27)
- h Drain hole
- i Anchor point (bolt 4× M12)

ERLQ_V3 (dimensions in mm)

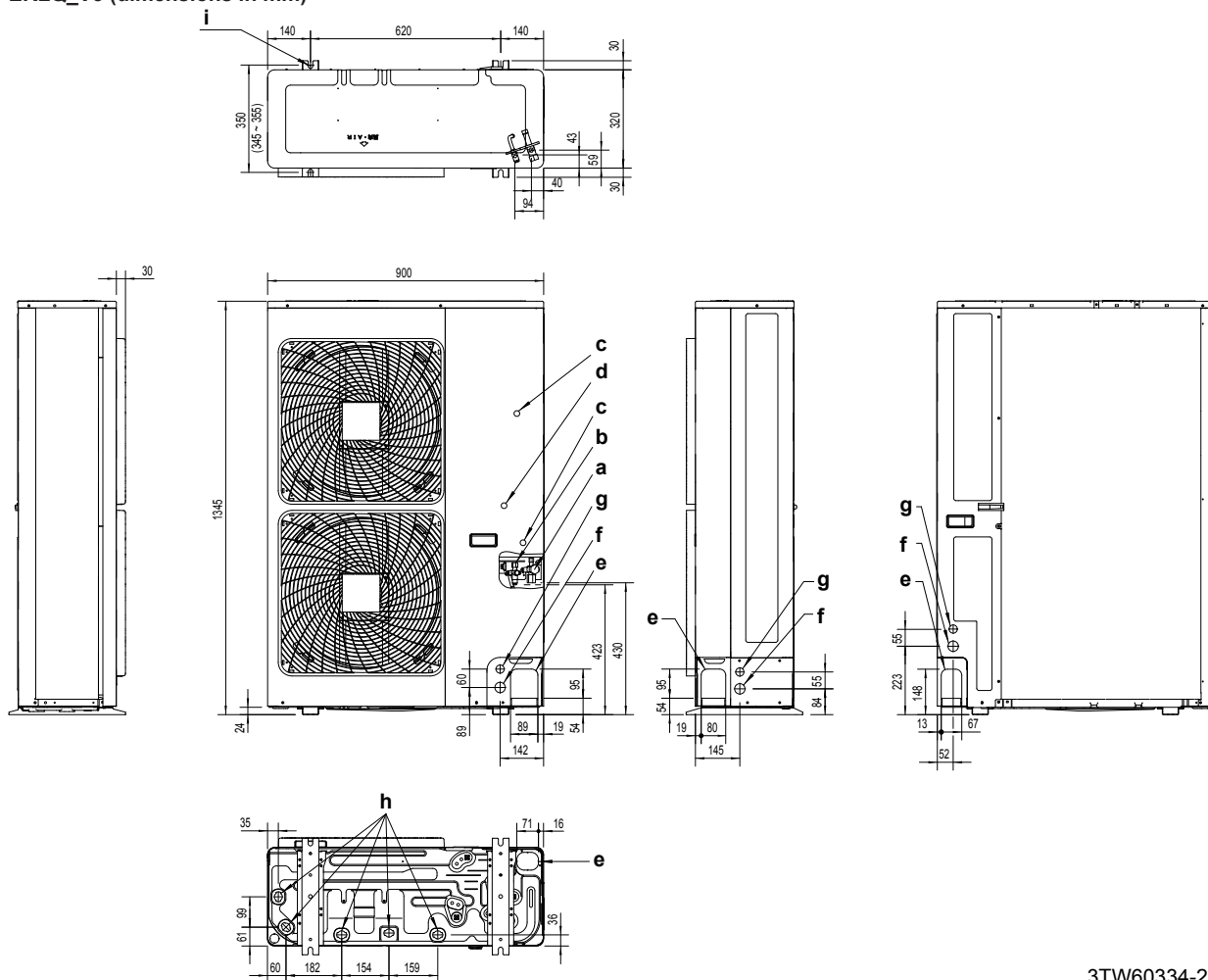

3TW60334-2

- a Gas pipe connection (Ø15.9 flare connection)
- b Liquid pipe connection (Ø9.5 flare connection)
- c Internal service port 5/16"
- d Electronic connection and earthing terminal M5 (in the switch box)
- e Refrigerant piping intake
- f Power supply wiring intake (knockout hole Ø34)
- g Control wiring intake (knockout hole Ø27)
- h Drain hole
- i Anchor point (bolt 4× M12)

14 Technical data

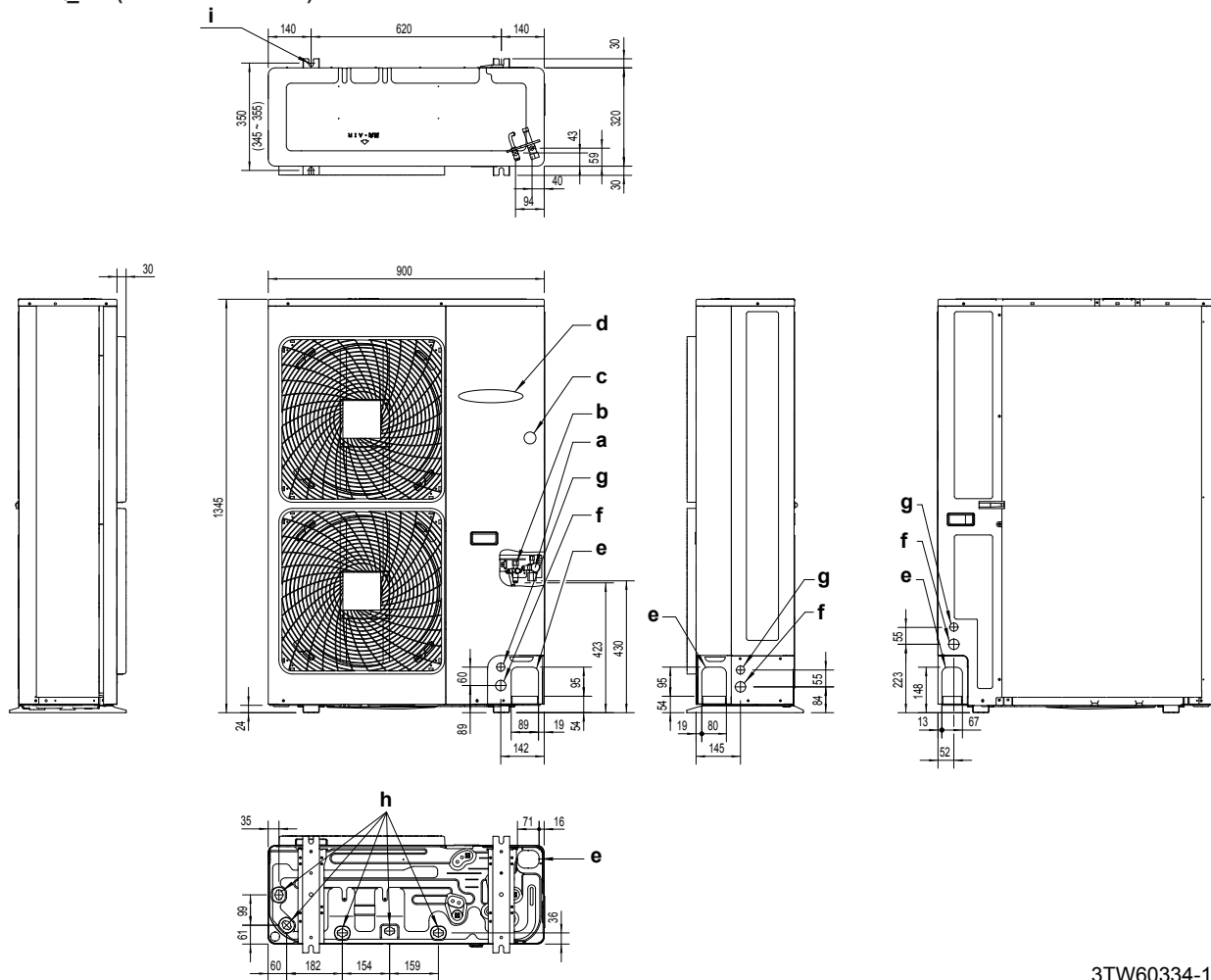

ERLQ_W1 (dimensions in mm)



3TW60334-1

- a Gas pipe connection (Ø15.9 flare connection)
- b Liquid pipe connection (Ø9.5 flare connection)
- c Internal service port 5/16"
- d Electronic connection and earthing terminal M5 (in the switch box)
- e Refrigerant piping intake
- f Power supply wiring intake (knockout hole Ø34)
- g Control wiring intake (knockout hole Ø27)
- h Drain hole
- i Anchor point (bolt 4× M12)

14.2.2 Service space: Outdoor unit

Single unit () | Single row of units ()

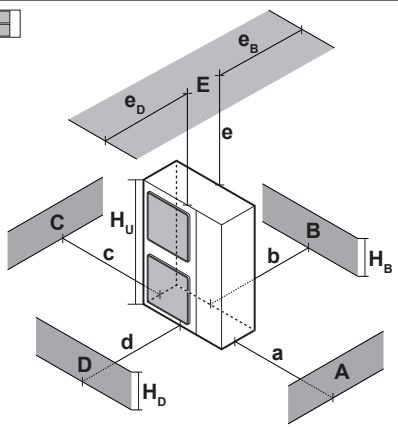
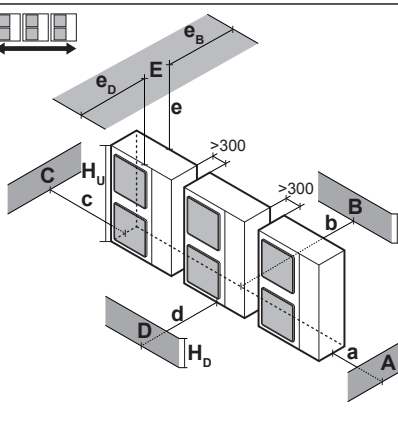
ERHQ	A~E	H _B H _D H _U	(mm)						e _B	e _D
			a	b	c	d	e			
	B	—		≥100						
	A, B, C	—		≥100	≥100	≥100				
	B, E	—			≥100			≥1000	≤500	
	A, B, C, E	—		≥150	≥150	≥150		≥1000	≤500	
	D	—					≥500			
	D, E	—					≥500	≥1000	≤500	
	B, D	—			≥100		≥500			
	B, D, E	H _B < H _D	H _B ≤ ½H _U		≥250		≥750	≥1000	≤500	1
			½H _U < H _B ≤ H _U		≥250		≥1000	≥1000	≤500	
			H _B > H _U	⊘						
H _B > H _D		H _B ≤ ½H _U		≥100		≥1000	≥1000	≤500		
	½H _U < H _B ≤ H _U		≥200		≥1000	≥1000	≤500			
		H _D > H _U	⊘							
	A, B, C	—	≥200	≥300	≥1000					
	A, B, C, E	—	≥200	≥300	≥1000		≥1000	≤500		
	D	—					≥1000			
	D, E	—					≥1000	≥1000	≤500	
	B, D	H _B < H _D	—		≥300		≥1000			
			H _D ≤ ½H _U		≥250		≥1500			
			½H _U < H _D ≤ H _U		≥300		≥1500			
	B, D, E	H _B < H _D	H _B ≤ ½H _U		≥300		≥1000	≥1000	≤500	1
			½H _U < H _B ≤ H _U		≥300		≥1250	≥1000	≤500	
			H _B > H _U	⊘						
H _B > H _D		H _B ≤ ½H _U		≥250		≥1500	≥1000	≤500		
	½H _U < H _B ≤ H _U		≥300		≥1500	≥1000	≤500			
		H _D > H _U	⊘							
									1+2	

- A, B, C, D** Obstacles (walls/baffle plates)
- E** Obstacle (roof)
- a, b, c, d, e** Minimum service space between the unit and obstacles A, B, C, D and E
- e_B** Maximum distance between the unit and the edge of obstacle E, in the direction of obstacle B
- e_D** Maximum distance between the unit and the edge of obstacle E, in the direction of obstacle D
- H_U** Height of the unit
- H_B, H_D** Height of obstacles B and D
- 1** Seal the bottom of the installation frame to prevent discharged air from flowing back to the suction side through the bottom of the unit.
- 2** Maximum two units can be installed.
- ⊘** Not allowed

14 Technical data

ERLQ

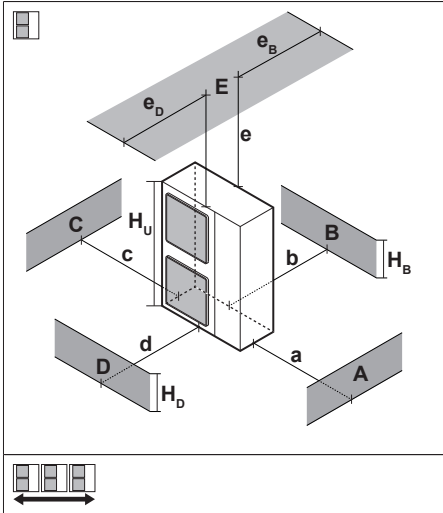

A~E	H _B H _D H _U	(mm)						
		a	b	c	d	e	e _B	e _D
B	—		≥200					
A, B, C	—	≥200	≥200	≥200				
B, E	—		≥200			≥1000		≤500
A, B, C, E	—	≥300	≥300	≥300		≥1000		≤500
D	—				≥500			
D, E	—				≥500	≥1000		≤500
B, D	—		≥200		≥500			
B, D, E	H _B < H _D	H _B ≤ ½H _U	≥350		≥750	≥1000		≤500
		½H _U < H _B ≤ H _U	≥350		≥1000	≥1000		≤500
	H _B > H _U	⊘						
	H _B > H _D	H _D ≤ ½H _U		≥200		≥1000	≥1000	
½H _U < H _D ≤ H _U			≥300		≥1000	≥1000		≤500
H _D > H _U		⊘						
		⊘						

- A, B, C, D Obstacles (walls/baffle plates)
- E Obstacle (roof)
- a, b, c, d, e Minimum service space between the unit and obstacles A, B, C, D and E
- e_B Maximum distance between the unit and the edge of obstacle E, in the direction of obstacle B
- e_D Maximum distance between the unit and the edge of obstacle E, in the direction of obstacle D
- H_U Height of the unit
- H_B, H_D Height of obstacles B and D
- 1 Recommended to prevent exposure to wind and snow.
- ⊘ Not allowed

Multiple rows of units

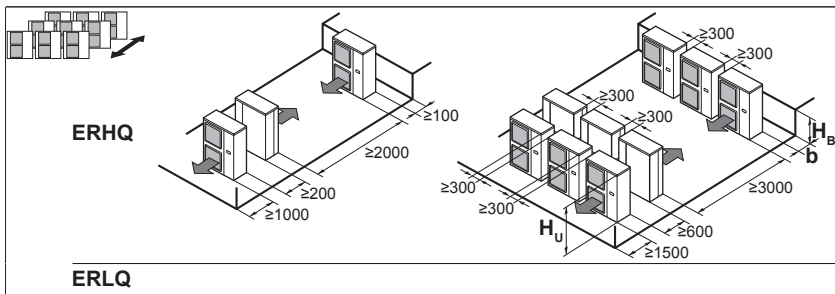

H _B H _U	b (mm)
H _B ≤ ½H _U	b ≥ 250
½H _U < H _B ≤ H _U	b ≥ 300
H _B > H _U	⊘
⊘	

14.2.3 Dimensions and service space: Indoor unit

Dimensions: Indoor unit

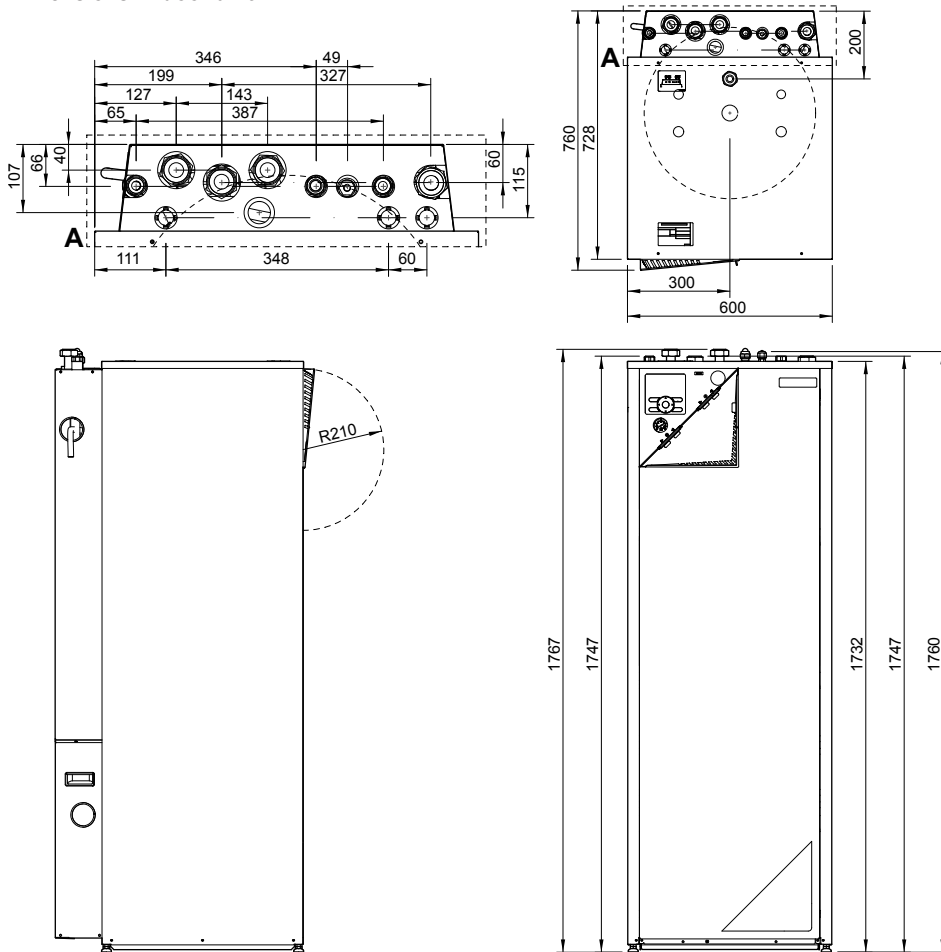

3D094406-1A

Service space: Indoor unit

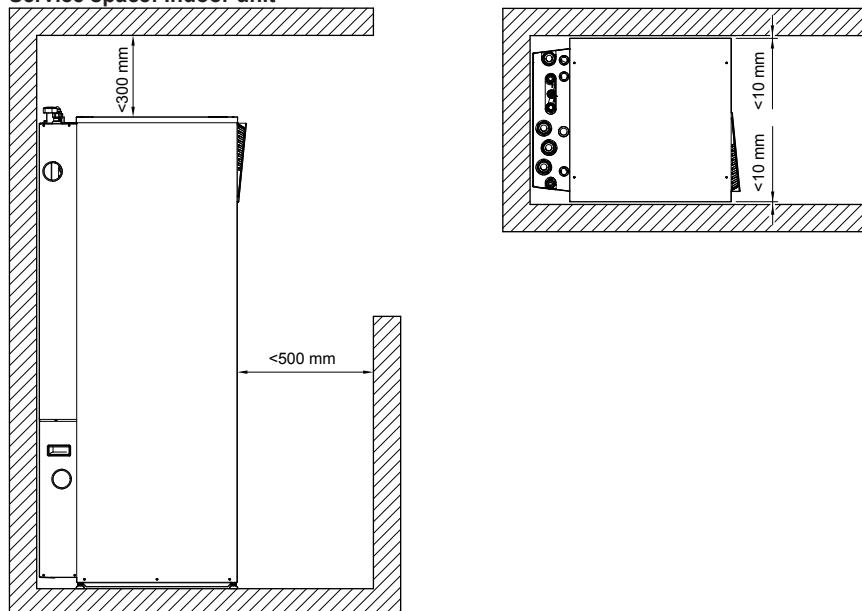

3D091992-1

14 Technical data

14.3 Center of gravity

14.3.1 Center of gravity: Outdoor unit

ERHQ_V3

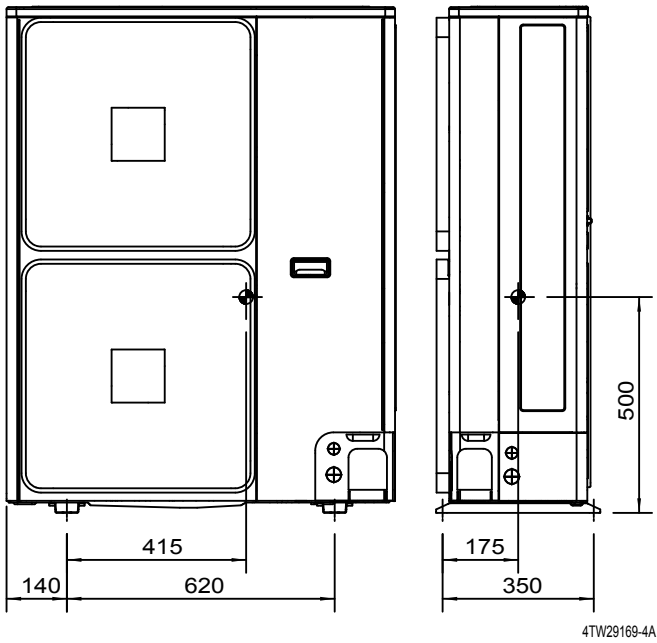

ERHQ_W1 + ERLQ_W1

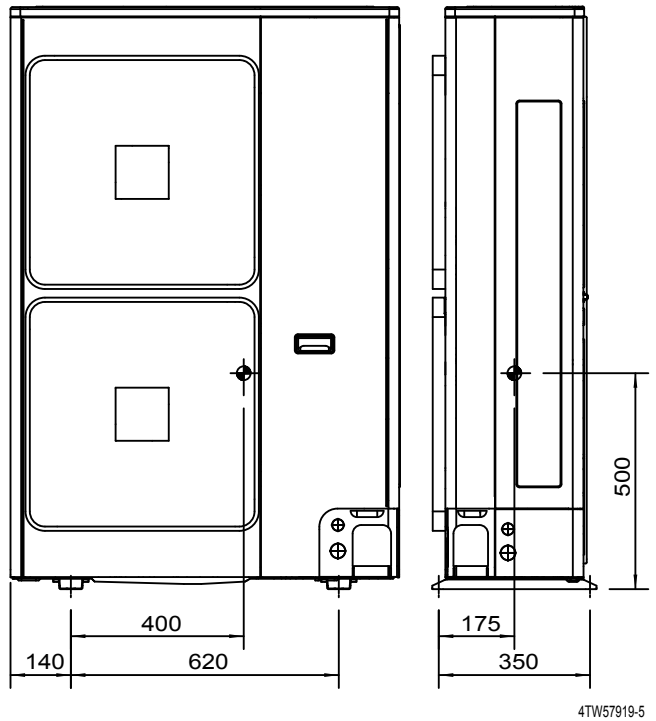

ERLQ_V3

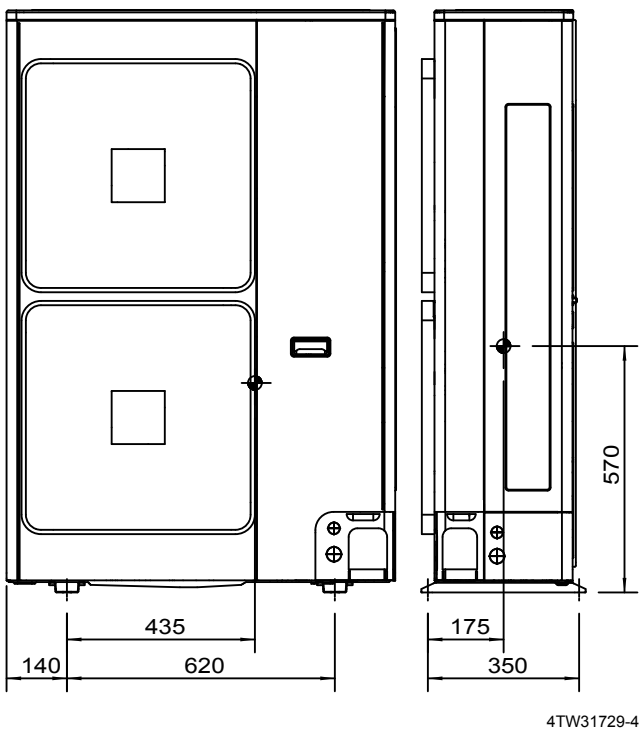

14.4 Components

14.4.1 Components: Outdoor unit

ERHQ_V3

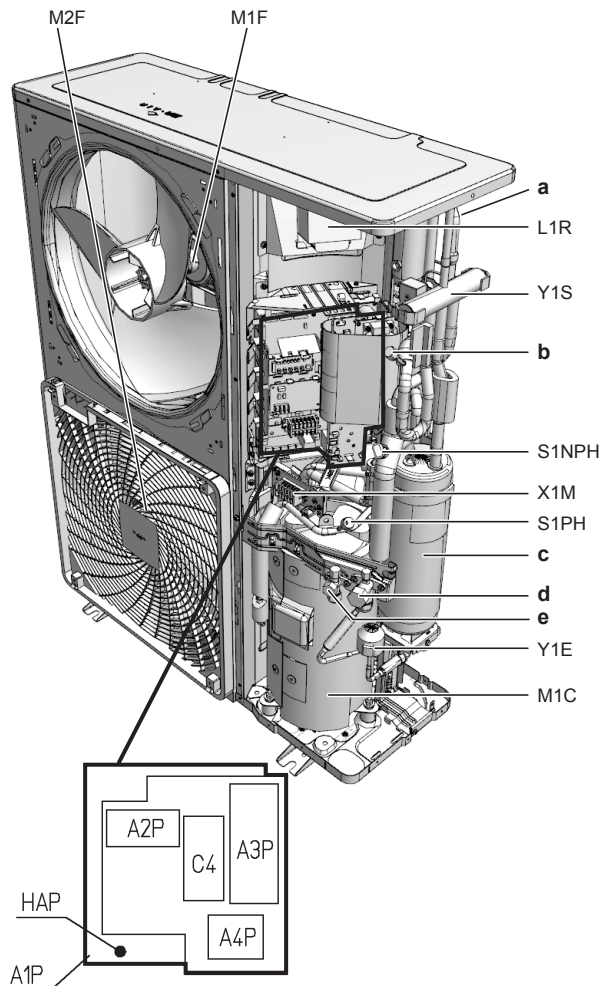

- a Heat exchanger (at the back)
- b Internal service port
- c Accumulator
- d Stop valve with service port (gas)
- e Stop valve with service port (liquid)
- A1P~A4P PCBs
- C4 Capacitor
- HAP Light emitting diode (service monitor green)
- L1R Reactor coil
- M1C Motor (compressor)
- M1F Motor (upper fan)
- M2F Motor (lower fan)
- S1NPH Pressure sensor
- S1PH High pressure switch
- X1M Terminal (communication and power supply)
- Y1E Electronic expansion valve
- Y1S Solenoid valve (4-way valve)

ERHQ_W1

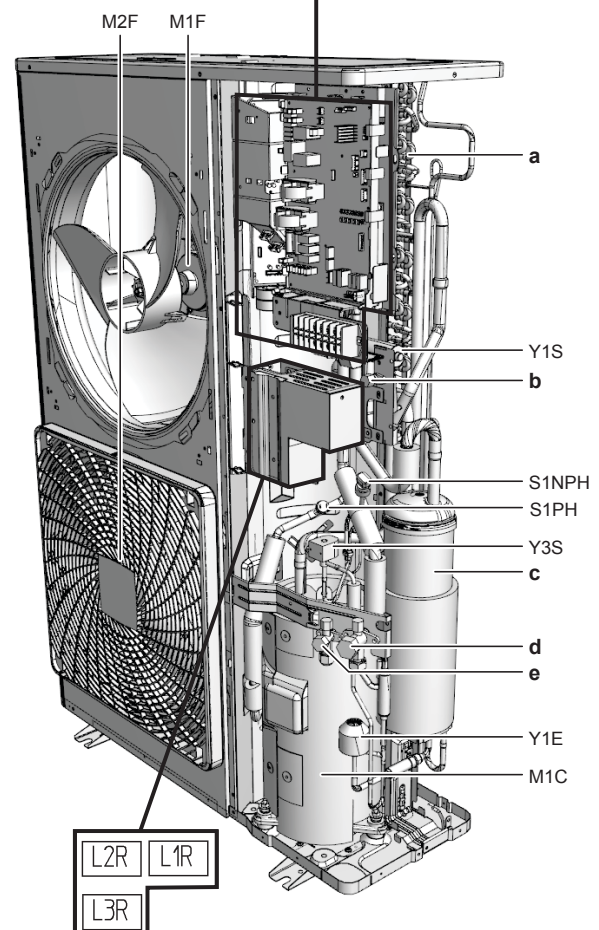
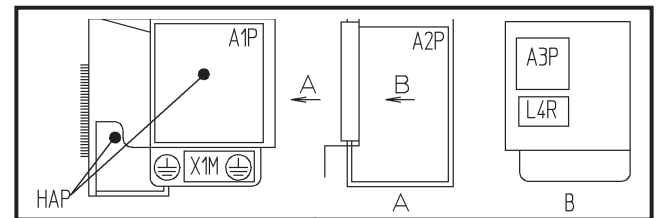

- a Heat exchanger (at the back)
- b Internal service port
- c Accumulator
- d Stop valve with service port (gas)
- e Stop valve with service port (liquid)
- A1P~A3P PCBs
- HAP Light emitting diode (service monitor green)
- L1R~L4R Reactor coils
- M1C Motor (compressor)
- M1F Motor (upper fan)
- M2F Motor (lower fan)
- S1NPH Pressure sensor
- S1PH High pressure switch
- X1M Terminal (communication and power supply)
- Y1E Electronic expansion valve
- Y1S Solenoid valve (4-way valve)
- Y3S Solenoid valve (injection)

14 Technical data

ERLQ_V3

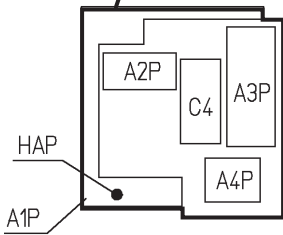
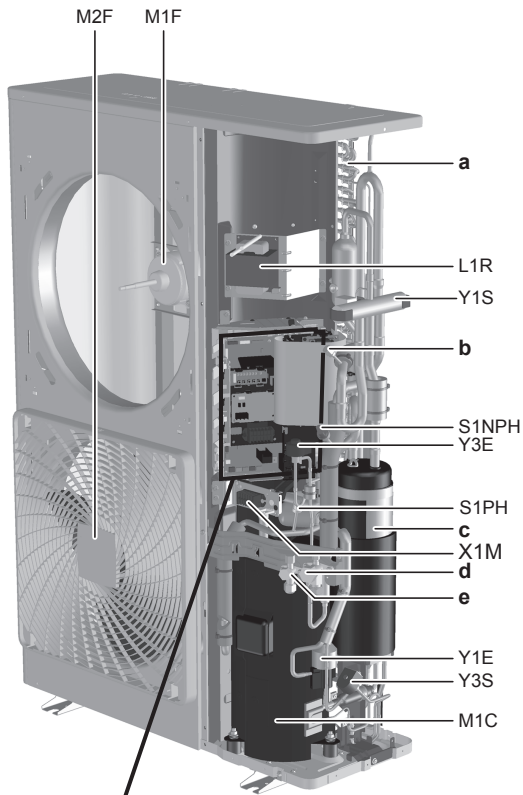

- a Heat exchanger (at the back)
- b Internal service port
- c Accumulator
- d Stop valve with service port (gas)
- e Stop valve with service port (liquid)
- A1P~A4P** PCBs
- C4** Capacitor
- HAP** Light emitting diode (service monitor green)
- L1R** Reactor coil
- M1C** Motor (compressor)
- M1F** Motor (upper fan)
- M2F** Motor (lower fan)
- S1NPH** Pressure sensor
- S1PH** High pressure switch
- X1M** Terminal (communication and power supply)
- Y1E** Electronic expansion valve (main)
- Y3E** Electronic expansion valve (injection)
- Y1S** Solenoid valve (4-way valve)
- Y3S** Solenoid valve (hot gas pass)

ERLQ_W1

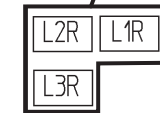
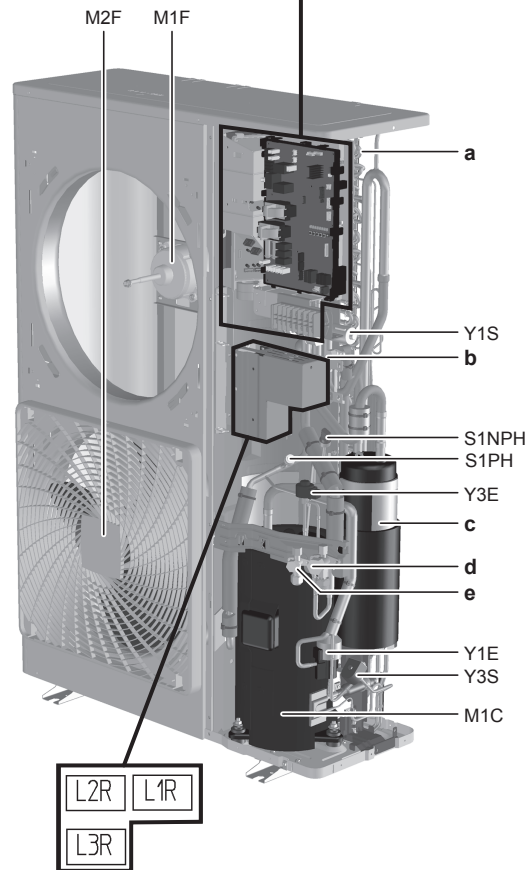
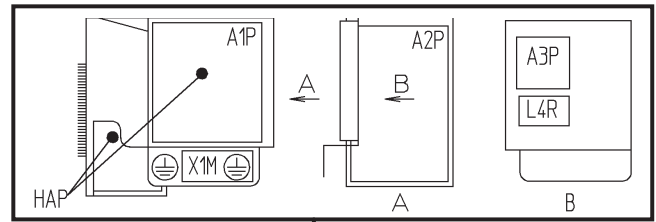

- a Heat exchanger (at the back)
- b Internal service port
- c Accumulator
- d Stop valve with service port (gas)
- e Stop valve with service port (liquid)
- A1P~A3P** PCBs
- HAP** Light emitting diode (service monitor green)
- L1R~L4R** Reactor coils
- M1C** Motor (compressor)
- M1F** Motor (upper fan)
- M2F** Motor (lower fan)
- S1NPH** Pressure sensor
- S1PH** High pressure switch
- X1M** Terminal (communication and power supply)
- Y1E** Electronic expansion valve (main)
- Y3E** Electronic expansion valve (injection)
- Y1S** Solenoid valve (4-way valve)
- Y3S** Solenoid valve (hot gas pass)

14.4.2 Components: Indoor unit

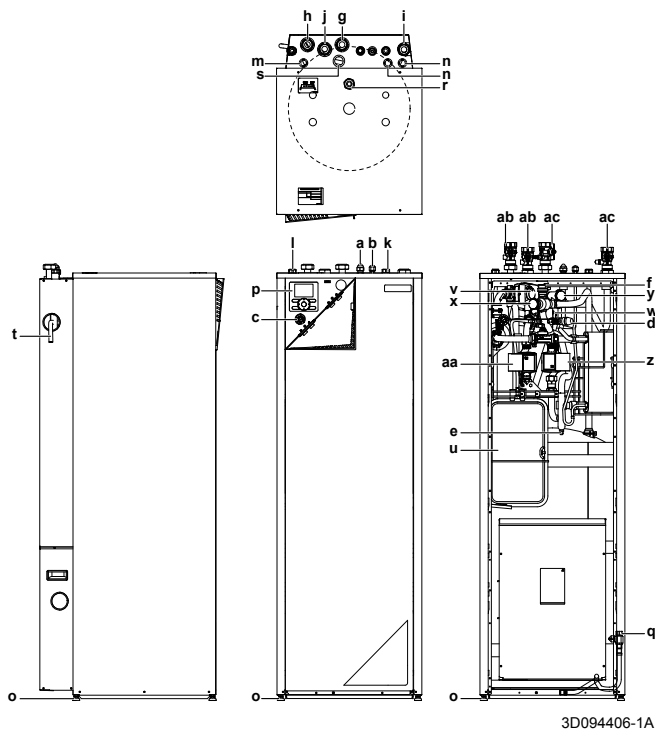

- a Gas pipe connection Ø15.9 mm flare
- b Liquid pipe connection Ø6.35 mm flare
- c Pressure gauge
- d Safety valve
- e Drain valve water circuit
- f Air purge
- g Water IN connection (main/mixed zone) 1-1/4" BSP (female)
- h Water OUT connection (main/mixed zone) 1-1/4" BSP (female)
- i Water IN connection (additional/direct zone) 1-1/4" BSP (female)
- j Water OUT connection (additional/direct zone) 1-1/4" BSP (female)
- k Domestic hot water: cold water IN 3/4" F BSP
- l Domestic hot water: cold water OUT 3/4" F BSP
- m Control wiring intake Ø24 mm
- n Power supply wiring intake Ø24 mm
- o Levelling feet
- p User interface (optional)
- q Drain valve domestic hot water tank circuit
- r Recirculation connection G 1/2" (female)
- s Hole for the recirculation piping or options wiring Ø35 mm
- t Drain outlet (unit+safety valve)
- u Expansion vessel
- v 3-way valve (space heating/domestic hot water)
- w 3-way valve (mixing valve for the main zone)
- x Water filter (additional/direct zone)
- y Water filter (main/mixed zone)
- z Pump (additional/direct zone)
- aa Pump (main/mixed zone)
- ab Shut-off valve
- ac Shut-off valve with fill valve (included accessory)

The additional zone is the temperature zone with the highest temperature. The main zone is the temperature with the lowest temperature.

14.4.3 Components: Switch box (indoor unit)

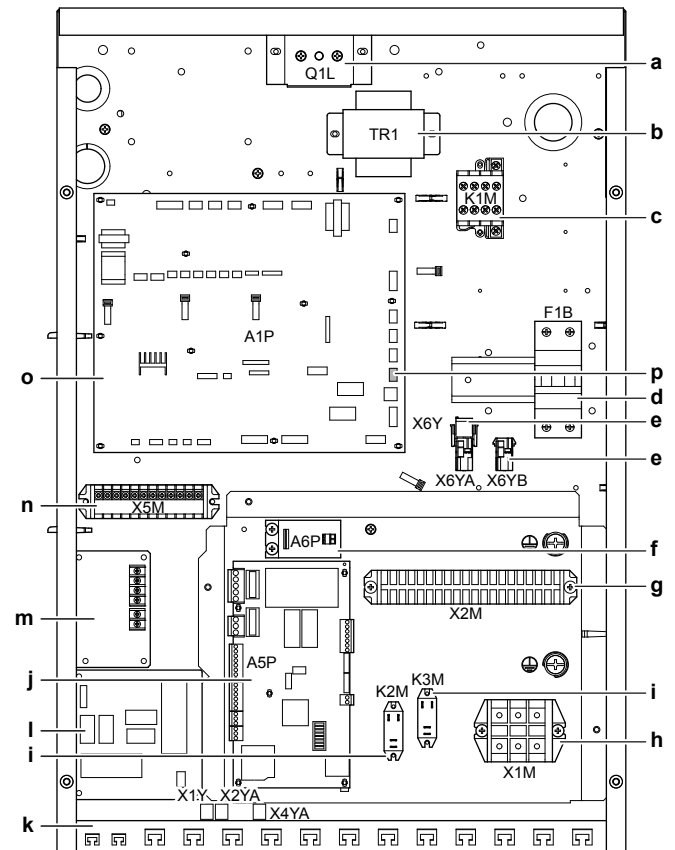

- a Backup heater thermal protector Q1L
- b Transformer TR1
- c Backup heater contactors K1M
- d Backup heater circuit breaker F1B
- e Connectors X6YA/X6YB/X6Y
- f Current loop PCB A6P
- g Terminal block X2M (high voltage)
- h Terminal block X1M (to outdoor unit)
- i 3-way valve relay K2M and K3M
- j Extension PCB A5P
- k Cable tie mountings
- l Digital I/O PCB A4P (only for installations with solar kit or digital I/O PCB kit)
- m Demand PCB for power limitation
- n Terminal block X5M (low voltage)
- o Main PCB A1P
- p PCB fuse FU1

14 Technical data

14.5 Piping diagram

14.5.1 Piping diagram: Outdoor unit

ERHQ_V3

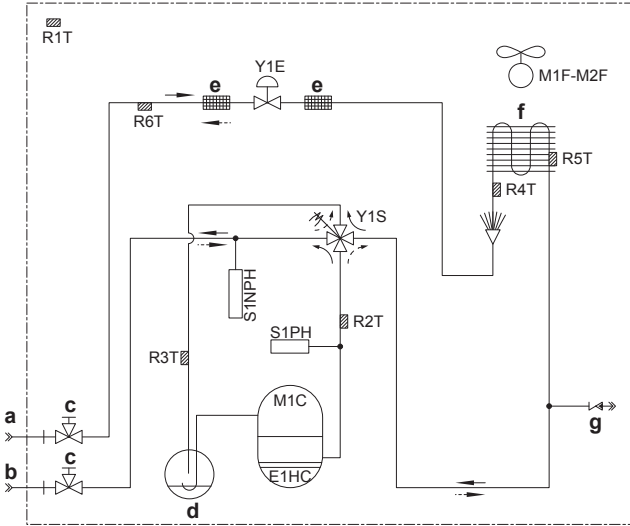

- b Field piping (gas: Ø15.9 flare connection)
- c Stop valve (with service port 5/16")
- d Accumulator
- e Filter
- f Heat exchanger
- g Internal service port 5/16"
- h Capillary tube
- E1HC Crankcase heater
- M1C Motor (compressor)
- M1F-M2F Motor (upper and lower fan)
- R1T Thermistor (air)
- R2T Thermistor (discharge)
- R3T Thermistor (suction)
- R4T Thermistor (heat exchanger)
- R5T Thermistor (heat exchanger middle)
- R6T Thermistor (liquid)
- S1NPH Pressure sensor
- S1PH High pressure switch
- Y1E Electronic expansion valve
- Y1S Solenoid valve (4-way valve)
- Y3S Solenoid valve (injection)
- Heating
- Cooling

ERLQ

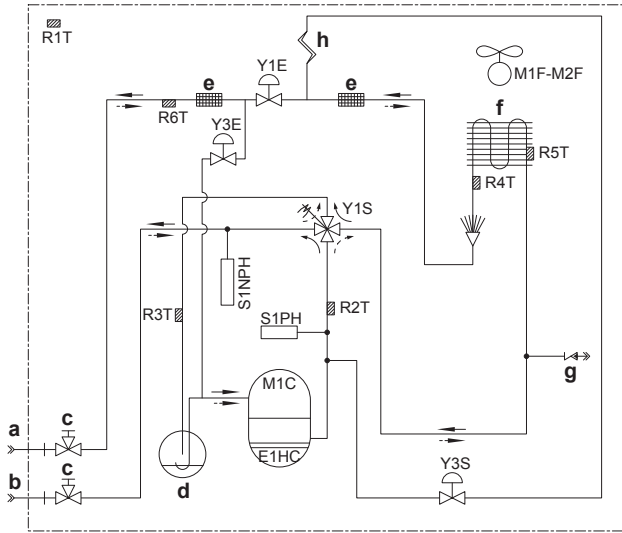

- a Field piping (liquid: Ø9.5 flare connection)
- b Field piping (gas: Ø15.9 flare connection)
- c Stop valve (with service port 5/16")
- d Accumulator
- e Filter
- f Heat exchanger
- g Internal service port 5/16"
- h Capillary tube
- E1HC Crankcase heater
- M1C Motor (compressor)
- M1F-M2F Motor (upper and lower fan)
- R1T Thermistor (air)
- R2T Thermistor (discharge)
- R3T Thermistor (suction)
- R4T Thermistor (heat exchanger)
- R5T Thermistor (heat exchanger middle)
- R6T Thermistor (liquid)
- S1NPH Pressure sensor
- S1PH High pressure switch
- Y1E Electronic expansion valve (main)
- Y3E Electronic expansion valve (injection)
- Y1S Solenoid valve (4-way valve)
- Y3S Solenoid valve (hot gas pass)
- Heating
- Cooling

ERHQ_W1

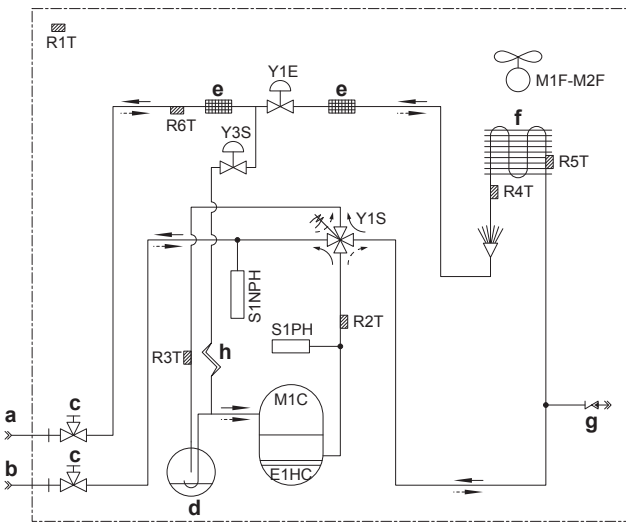



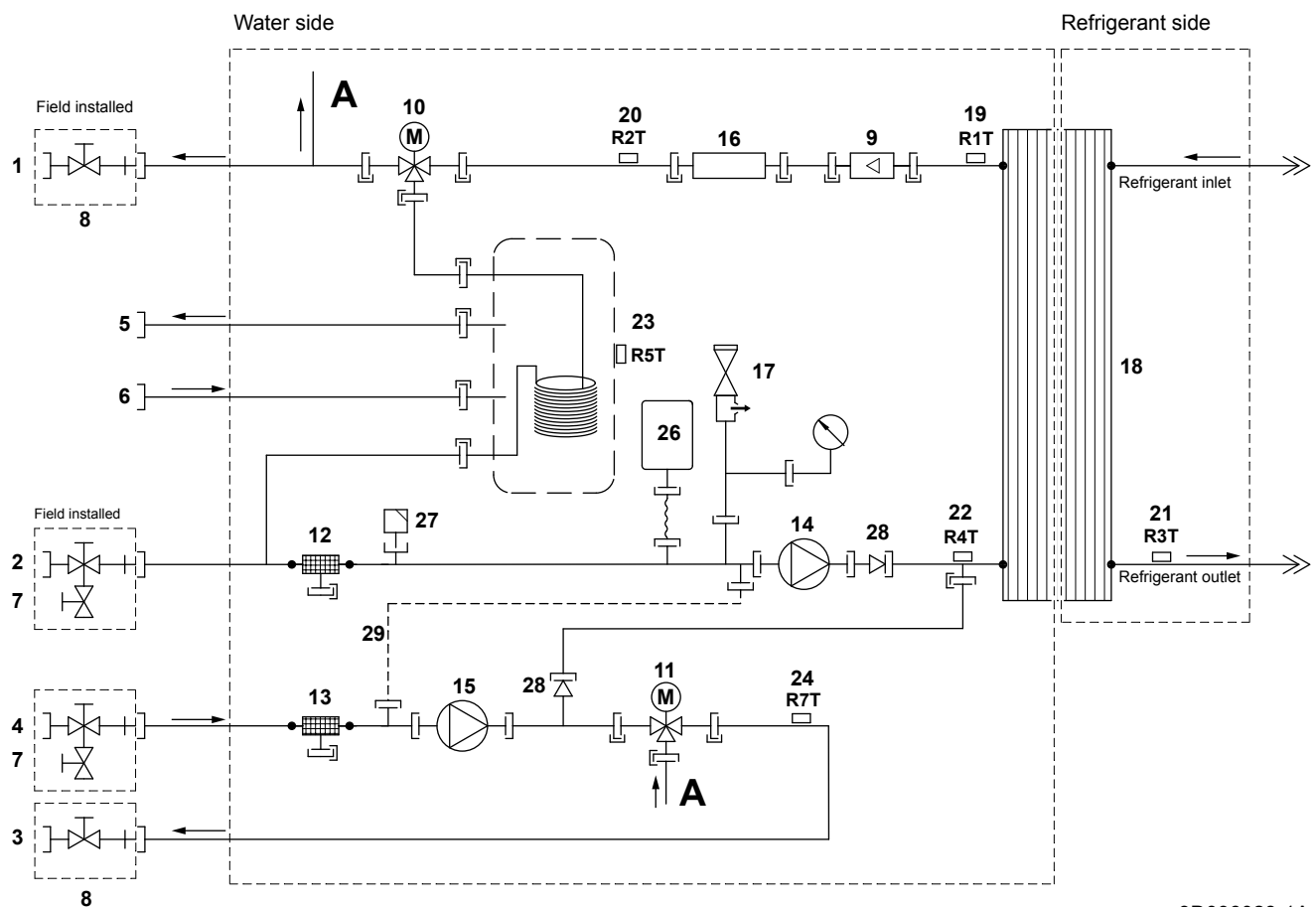

a Field piping (liquid: Ø9.5 flare connection)

14.5.2 Piping diagram: Indoor unit



3D096028-1A

- 1 Space heating – water OUT (additional/direct zone)
 - 2 Space heating – water IN (additional/direct zone)
 - 3 Space heating – water OUT (main/mixed zone)
 - 4 Space heating – water IN (main/mixed zone)
 - 5 Domestic hot water: hot water out
 - 6 Domestic hot water: cold water in
 - 7 Shut-off valve with drain/fill valve
 - 8 Shut-off valve
 - 9 Flow sensor
 - 10 3-way valve (space heating/domestic hot water)
 - 11 3-way valve (mixing valve for the main/mixed zone)
 - 12 Water filter (additional/direct zone)
 - 13 Water filter (main/mixed zone)
 - 14 Pump (additional/direct zone)
 - 15 Pump (main/mixed zone)
 - 16 Backup heater
 - 17 Safety valve
 - 18 Plate heat exchanger
 - 19 R1T – Outlet water heat exchanger thermistor
 - 20 R2T – Outlet water backup heater thermistor
 - 21 R3T – Thermistor (heat exchanger, liquid pipe)
 - 22 R4T – Inlet water thermistor
 - 23 R5T – Tank thermistor
 - 24 R7T – Water outlet thermistor (main/mixed zone)
 - 26 Expansion vessel
 - 27 Air purge
 - 28 Check valve
 - 29 Capillary tube
-  Screw connection
 Flare connection
 Quick coupling
 Brazed connection

14 Technical data

14.6 Wiring diagram

14.6.1 Wiring diagram: Outdoor unit

ERHQ_V3

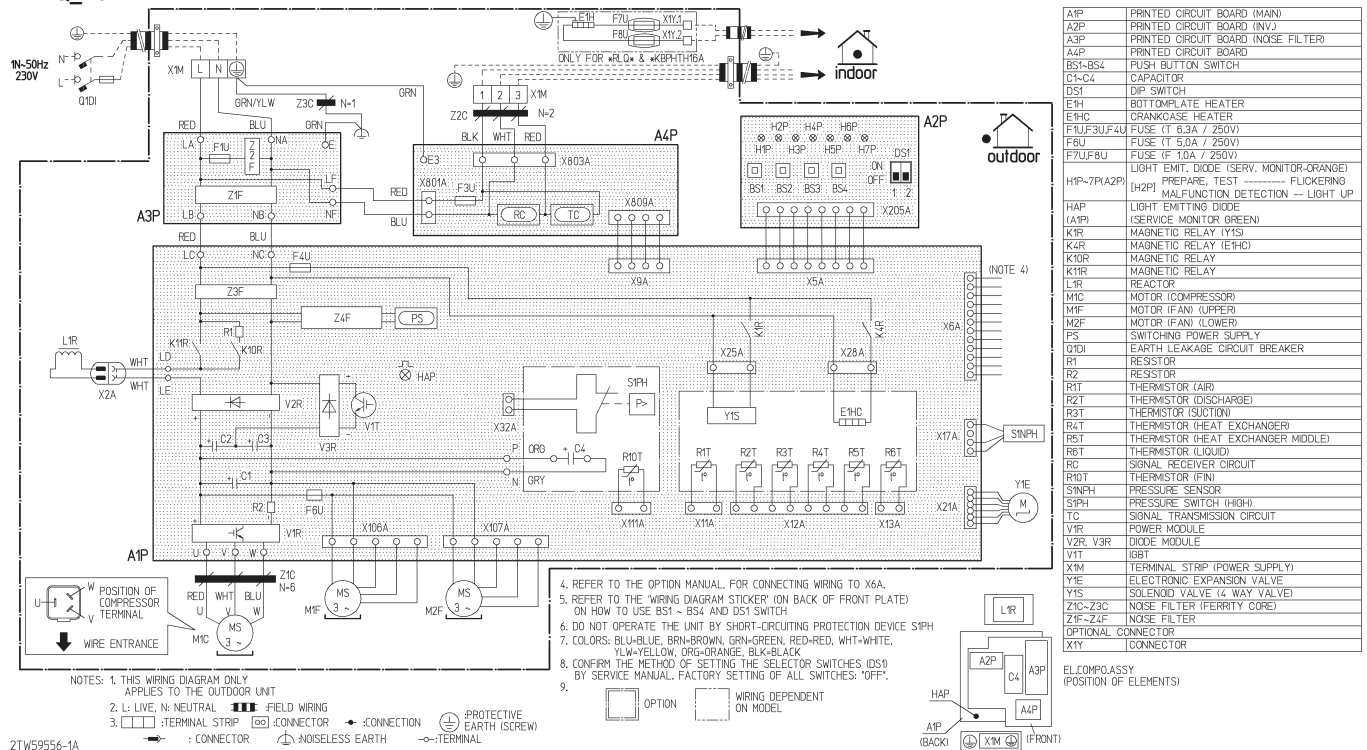

Notes:

- 1 This wiring diagram applies only to the outdoor unit.
- 2 Symbols (see below).
- 3 Symbols (see below).
- 4 Refer to the option manual for connecting wiring to X6A.
- 5 Refer to the wiring diagram sticker (on the back of the service cover) for how to use the BS1~BS4 and DS1 switches.
- 6 When operating, do not short-circuit protective device S1PH.
- 7 Colours (see below).
- 8 Refer to the service manual for instructions on how to set the selector switches (DS1). The factory setting of all switches is OFF.
- 9 Symbols (see below).

Symbols:

- L Live
- N Neutral
- [Symbol] Field wiring
- [Symbol] Terminal strip
- [Symbol] Connector
- [Symbol] Connector
- [Symbol] Connection
- [Symbol] Protective earth (screw)
- [Symbol] Noiseless earth
- [Symbol] Terminal
- [Symbol] Option
- [Symbol] Wiring dependent on model

Colours:

- BLK Black
- BLU Blue
- BRN Brown
- GRN Green
- ORG Orange
- RED Red
- WHT White
- YLW Yellow

Legend:

- A1P Printed circuit board (main)
- A2P Printed circuit board (inverter)
- A3P Printed circuit board (noise filter)
- A4P Printed circuit board
- BS1~BS4 Push button switch
- C1~C4 Capacitor
- DS1 DIP switch
- E1H Bottom plate heater
- E1HC Crankcase heater
- F1U, F3U, F4U Fuse (T 6.3 A / 250 V)
- F6U Fuse (T 5.0 A / 250 V)
- F7U, F8U Fuse (F 1.0 A / 250 V)
- H1P~H7P (A2P) Light-emitting diode (service monitor orange)
- H2P:
 - Prepare, test: Flickering
 - Malfunction detection: Light up

HAP (A1P)	Light-emitting diode (service monitor green)
K1R	Magnetic relay (Y1S)
K4R	Magnetic relay (E1HC)
K10R	Magnetic relay
K11R	Magnetic relay
L1R	Reactor
M1C	Motor (compressor)
M1F	Motor (upper fan)
M2F	Motor (lower fan)
PS	Switching power supply
Q1DI	Earth leakage circuit breaker (field supply)
R1	Resistor
R2	Resistor
R1T	Thermistor (air)
R2T	Thermistor (discharge)
R3T	Thermistor (suction)
R4T	Thermistor (heat exchanger)
R5T	Thermistor (heat exchanger middle)
R6T	Thermistor (liquid)
R10T	Thermistor (fin)
RC	Signal receiver circuit
S1NPH	Pressure sensor
S1PH	High pressure switch
TC	Signal transmission circuit
V1R	Power module
V2R, V3R	Diode module
V1T	Insulated gate bipolar transistor (IGBT)
X1M	Terminal strip (power supply)
X1Y	Connector (option)
X6A	Connector (option)
Y1E	Electronic expansion valve
Y1S	Solenoid valve (4-way valve)
Z1C~Z3C	Noise filter (ferrite core)
Z1F~Z4F	Noise filter

14 Technical data

ERHQ_W1

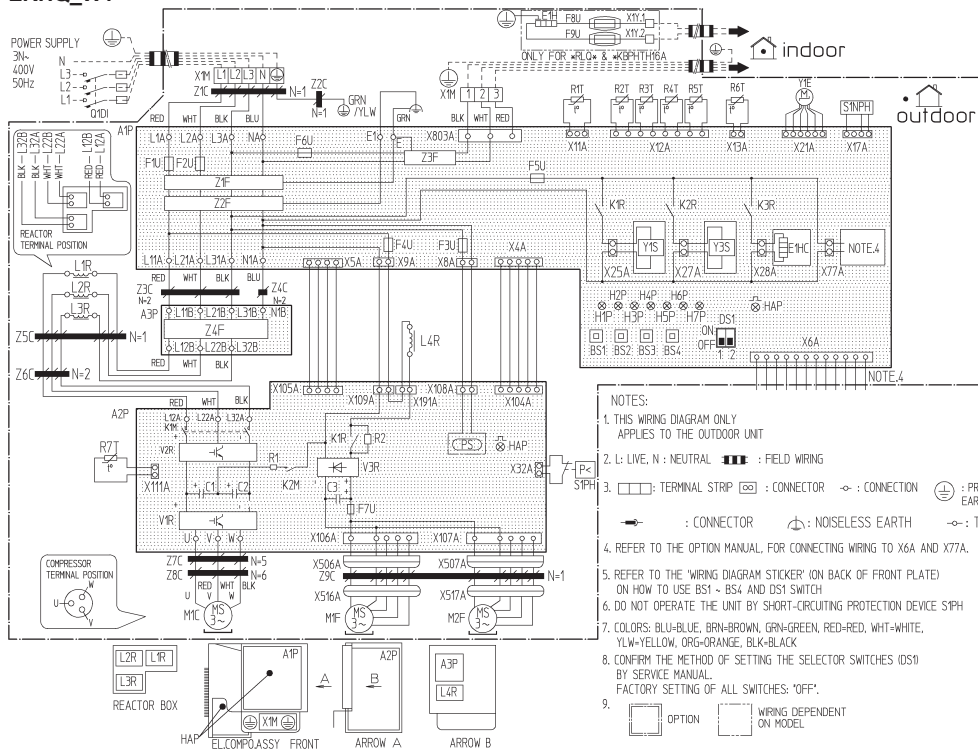

A1P	PRINTED CIRCUIT BOARD
A2P	PRINTED CIRCUIT BOARD (INV.)
A3P	PRINTED CIRCUIT BOARD (NOISE FILTER)
BS1-BS4	PUSH BUTTON SWITCH
C1-C4	CAPACITOR
DS1	DIP SWITCH
E1H	CRANKCASE HEATER
E1HC	BOTTOMPLATE HEATER
F1U	FUSE (31.5A / 500V)
F2U	FUSE (31.5A / 500V)
F3U	FUSE (T 6.3A / 250V)
F4U	FUSE (T 6.3A / 250V)
F5U	FUSE (T 6.3A / 250V)
F6U	FUSE (T 6.3A / 250V)
F7U	FUSE (T 5.0A / 250V)
F8U, F9U	FUSE (F 1.0A / 250V)
HAP (A1P)	PILOT LAMP (SERVICE MONITOR-GREEN)
HAP (A2P)	PILOT LAMP (SERVICE MONITOR-GREEN)
H1P~H7P (A1P)	PILOT LAMP (SERVICE MONITOR-ORANGE)
K1M - K2M	MAGNETIC CONTACTOR
K1R (A1P)	MAGNETIC RELAY (Y1S)
K1R (A2P)	MAGNETIC RELAY
K2R (A1P)	MAGNETIC RELAY (Y2S)
K3R (A1P)	MAGNETIC RELAY (E1HC)
L1R - L3R	REACTOR
L4R	REACTOR (FOR OUTDOOR FAN MOTOR)
M1C	MOTOR (COMPRESSOR)
M1F	MOTOR (FAN) (UPPER)
M2F	MOTOR (FAN) (LOWER)
PS	SWITCHING POWER SUPPLY
R1 - R4	RESISTOR
R1T	THERMISTOR (AIR)
R2T	THERMISTOR (DISCHARGE)
R3T	THERMISTOR (SUCTION)
R4T	THERMISTOR (HEAT EXCHANGER)
R5T	THERMISTOR (HEAT EXCHANGER MIDDLE)
R6T	THERMISTOR (LIQUID)
R7T	THERMISTOR (FIN)
S1NPH	PRESSURE SENSOR
S1PH	PRESSURE SWITCH (HIGH)
S1PH	POWER MODULE
V1R - V2R	DIODE MODULE
X1M	TERMINAL STRIP
Y1E	ELECTRONIC EXPANSION VALVE
Y1S	SOLENOID VALVE (4 WAY VALVE)
Y3S	SOLENOID VALVE
Z1C-Z8C	NOISE FILTER
Z1F-Z4F	NOISE FILTER
Z1D	EARTH LEAKAGE CIRCUIT BREAKER
OPTIONAL CONNECTOR	
X6A	CONNECTOR
X77A	CONNECTOR
X1Y	CONNECTOR

- NOTES:**
- THIS WIRING DIAGRAM ONLY APPLIES TO THE OUTDOOR UNIT
 - L: LIVE, N: NEUTRAL, ---: FIELD WIRING
 - : TERMINAL STRIP, □: CONNECTOR, ○: CONNECTION, ⊕: PROTECTIVE EARTH (SCREW), ⊕: NOISELESS EARTH, ○: TERMINAL
 - REFER TO THE OPTION MANUAL, FOR CONNECTING WIRING TO X6A AND X77A.
 - REFER TO THE 'WIRING DIAGRAM STICKER' (ON BACK OF FRONT PLATE) ON HOW TO USE BS1 - BS4 AND DS1 SWITCH
 - DO NOT OPERATE THE UNIT BY SHORT-CIRCUITING PROTECTION DEVICE S1PH
 - COLORS: BLU-BLUE, BRN-BROWN, GRN-GREEN, RED-RED, WHT-WHITE, YLW-YELLOW, ORG-ORANGE, BLK-BLACK
 - CONFIRM THE METHOD OF SETTING THE SELECTOR SWITCHES (DS1) BY SERVICE MANUAL. FACTORY SETTING OF ALL SWITCHES: 'OFF'.
 - OPTION: OPTION, WIRING DEPENDENT ON MODEL

Notes:

- This wiring diagram applies only to the outdoor unit.
- Symbols (see below).
- Symbols (see below).
- Refer to the option manual for connecting wiring to X6A and X77A.
- Refer to the wiring diagram sticker (on the back of the service cover) for how to use the BS1~BS4 and DS1 switches.
- When operating, do not short-circuit protective device S1PH.
- Colours (see below).
- Refer to the service manual for instructions on how to set the selector switches (DS1). The factory setting of all switches is OFF.
- Symbols (see below).

Symbols:

- L Live
- N Neutral
- Field wiring
- Terminal strip
- Connector
- Connector
- Connection
- ⊕ Protective earth (screw)
- ⊕ Noiseless earth
- Terminal
- Option
- Wiring dependent on model

Colours:

- BLK Black
- BLU Blue
- BRN Brown

- GRN Green
- ORG Orange
- RED Red
- WHT White
- YLW Yellow

Legend:

- A1P Printed circuit board
- A2P Printed circuit board (inverter)
- A3P Printed circuit board (noise filter)
- BS1~BS4 Push button switch
- C1~C4 Capacitor
- DS1 DIP switch
- E1H Bottom plate heater
- E1HC Crankcase heater
- F1U Fuse (31.5 A / 500 V)
- F2U Fuse (31.5 A / 500 V)
- F3U Fuse (T 6.3 A / 250 V)
- F4U Fuse (T 6.3 A / 250 V)
- F5U Fuse (T 6.3 A / 250 V)
- F6U Fuse (T 6.3 A / 250 V)
- F7U Fuse (T 5.0 A / 250 V)
- F8U, F9U Fuse (F 1.0 A / 250 V)
- HAP (A1P) Light-emitting diode (service monitor green)
- HAP (A2P) Light-emitting diode (service monitor green)
- H1P~H7P (A1P) Light-emitting diode (service monitor orange)
- K1M, K2M Magnetic contactor
- K1R (A1P) Magnetic relay (Y1S)
- K1R (A2P) Magnetic relay
- K2R (A1P) Magnetic relay (Y3S)

K3R (A1P)	Magnetic relay (E1HC)
L1R~L3R	Reactor
L4R	Reactor (for outdoor fan motor)
M1C	Motor (compressor)
M1F	Motor (upper fan)
M2F	Motor (lower fan)
PS	Switching power supply
Q1DI	Earth leakage circuit breaker (field supply)
R1~R4	Resistor
R1T	Thermistor (air)
R2T	Thermistor (discharge)
R3T	Thermistor (suction)
R4T	Thermistor (heat exchanger)
R5T	Thermistor (heat exchanger middle)
R6T	Thermistor (liquid)
R7T	Thermistor (fin)
S1NPH	Pressure sensor
S1PH	High pressure switch
V1R, V2R	Power module
V3R	Diode module
X1M	Terminal strip (power supply)
X1Y	Connector (option)
X6A	Connector (option)
X77A	Connector (option)
Y1E	Electronic expansion valve
Y1S	Solenoid valve (4-way valve)
Y3S	Solenoid valve (injection)
Z1C~Z9C	Noise filter
Z1F~Z4F	Noise filter

14 Technical data

ERLQ_V3

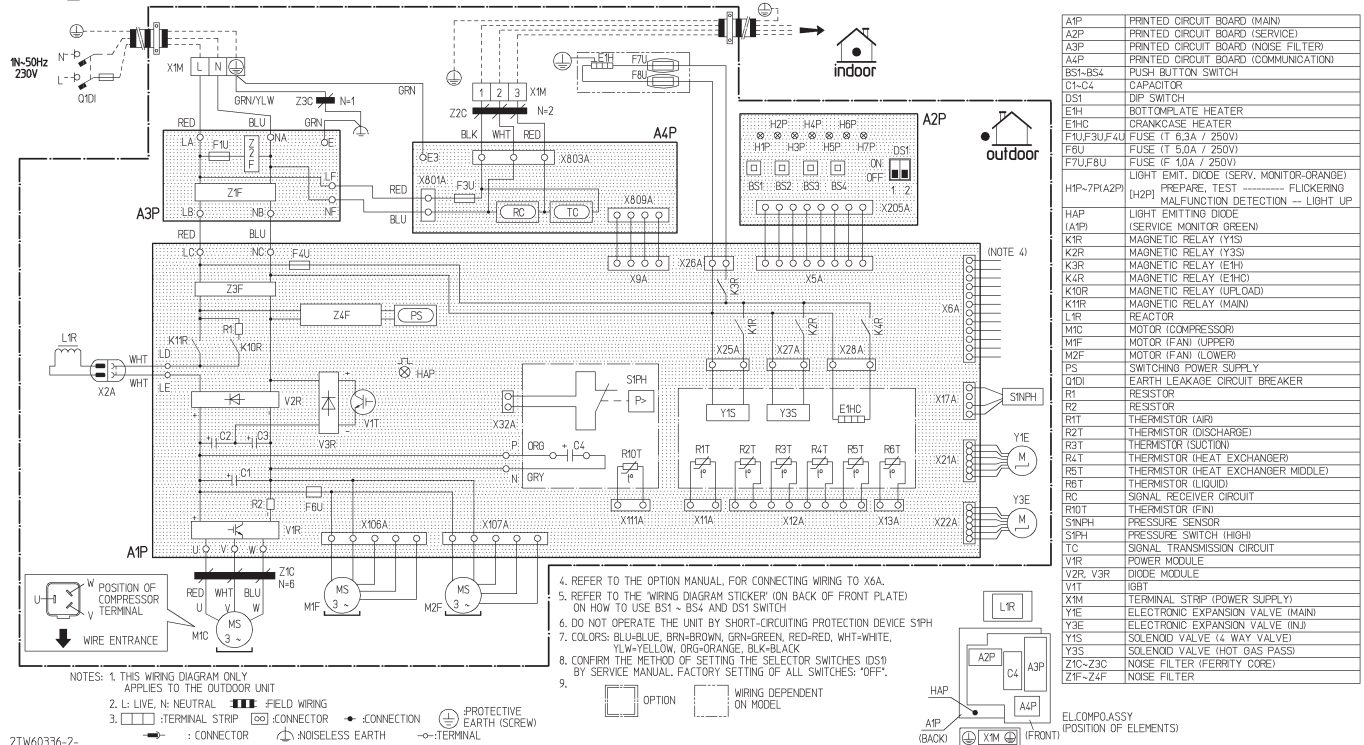

A1P	PRINTED CIRCUIT BOARD (MAIN)
A2P	PRINTED CIRCUIT BOARD (SERVICE)
A3P	PRINTED CIRCUIT BOARD (NOISE FILTER)
A4P	PRINTED CIRCUIT BOARD (COMMUNICATION)
BS1-BS4	PUSH BUTTON SWITCH
C1-C4	CAPACITOR
DS1	DIP SWITCH
E1H	BOTTOM PLATE HEATER
E1HC	CRANKCASE HEATER
F1U,F3U,F4U	FUSE (T 6.3A / 250V)
F6U	FUSE (T 5.0A / 250V)
F7U,F8U	FUSE (F 1.0A / 250V)
H1P~H7P	LIGHT EMIT. DIODE (SERV. MONITOR-ORANGE)
H2P	PREPARE, TEST
H3P	FLICKERING
H4P~H7P	MALFUNCTION DETECTION - LIGHT UP
HAP	LIGHT EMITTING DIODE (SERVICE MONITOR GREEN)
K1R	MAGNETIC RELAY (Y1S)
K2R	MAGNETIC RELAY (Y3S)
K3R	MAGNETIC RELAY (E1H)
K4R	MAGNETIC RELAY (E1HC)
K10R	MAGNETIC RELAY (UPLOAD)
K11R	MAGNETIC RELAY (MAIN)
L1R	REACTOR
M1F	MOTOR (FANI UPPER)
M2F	MOTOR (FANI LOWER)
PS	SWITCHING POWER SUPPLY
Q1D1	EARTH LEAKAGE CIRCUIT BREAKER
R1	RESISTOR
R2	RESISTOR
R1T	THERMISTOR (AIR)
R2T	THERMISTOR (DISCHARGE)
R3T	THERMISTOR (SUCTION)
R4T	THERMISTOR (HEAT EXCHANGER)
R5T	THERMISTOR (HEAT EXCHANGER MIDDLE)
R6T	THERMISTOR (LIQUID)
RC	SIGNAL RECEIVER CIRCUIT
RC1	THERMISTOR (IFANI)
S1PH	PRESSURE SENSOR
S1PHH	PRESSURE SWITCH (HIGH)
STC	SIGNAL TRANSMISSION CIRCUIT
V1R	POWER MODULE
V2R, V3R	DIODE MODULE
VIT	IGBT
X1M	TERMINAL STRIP (POWER SUPPLY)
Y1E	ELECTRONIC EXPANSION VALVE (MAIN)
Y3E	ELECTRONIC EXPANSION VALVE (INJ)
Y1S	SOLENOID VALVE (4-WAY VALVE)
Y3S	SOLENOID VALVE (HOT GAS PASS)
Z1C-Z3C	NOISE FILTER (FERRITY CORE)
Z1F-Z4F	NOISE FILTER

Notes:

- This wiring diagram applies only to the outdoor unit.
- Symbols (see below).
- Symbols (see below).
- Refer to the option manual for connecting wiring to X6A.
- Refer to the wiring diagram sticker (on back of the service cover) for how to use the BS1~BS4 and DS1 switches.
- When operating, do not short-circuit protective device S1PH.
- Colours (see below).
- Refer to the service manual for instructions on how to set the selector switches (DS1). The factory setting of all switches is OFF.
- Symbols (see below).

Symbols:

- L Live
- N Neutral
- Field wiring
- Terminal strip
- Connector
- Connector
- Connection
- Protective earth (screw)
- Noiseless earth
- Terminal
- Option
- Wiring dependent on model

Colours:

- BLK Black
- BLU Blue
- BRN Brown

- GRN Green
- ORG Orange
- RED Red
- WHT White
- YLW Yellow

Legend:

- A1P Printed circuit board (main)
- A2P Printed circuit board (service)
- A3P Printed circuit board (noise filter)
- A4P Printed circuit board (communication)
- BS1~BS4 Push button switch
- C1~C4 Capacitor
- DS1 DIP switch
- E1H Bottom plate heater
- E1HC Crankcase heater
- F1U, F3U, F4U Fuse (T 6.3 A / 250 V)
- F6U Fuse (T 5.0 A / 250 V)
- F7U, F8U Fuse (F 1.0 A / 250 V)
- H1P~H7P (A2P) Light-emitting diode (service monitor orange)
- H2P:
 - Prepare, test: Flickering
 - Malfunction detection: Light up
- HAP Light-emitting diode (service monitor green)
- K1R Magnetic relay (Y1S)
- K2R Magnetic relay (Y3S)
- K3R Magnetic relay (E1H)
- K4R Magnetic relay (E1HC)
- K10R Magnetic relay (upload)
- K11R Magnetic relay (main)

L1R	Reactor
M1C	Motor (compressor)
M1F	Motor (upper fan)
M2F	Motor (lower fan)
PS	Switching power supply
Q1DI	Earth leakage circuit breaker (field supply)
R1	Resistor
R2	Resistor
R1T	Thermistor (air)
R2T	Thermistor (discharge)
R3T	Thermistor (suction)
R4T	Thermistor (heat exchanger)
R5T	Thermistor (heat exchanger middle)
R6T	Thermistor (liquid)
R10T	Thermistor (fin)
RC	Signal receiver circuit
S1NPH	Pressure sensor
S1PH	High pressure switch
TC	Signal transmission circuit
V1R	Power module
V2R, V3R	Diode module
V1T	Insulated gate bipolar transistor (IGBT)
X1M	Terminal strip (power supply)
X6A	Connector (option)
Y1E	Electronic expansion valve (main)
Y3E	Electronic expansion valve (injection)
Y1S	Solenoid valve (4-way valve)
Y3S	Solenoid valve (hot gas pass)
Z1C~Z3C	Noise filter (ferrite core)
Z1F~Z4F	Noise filter

14 Technical data

ERLQ_W1

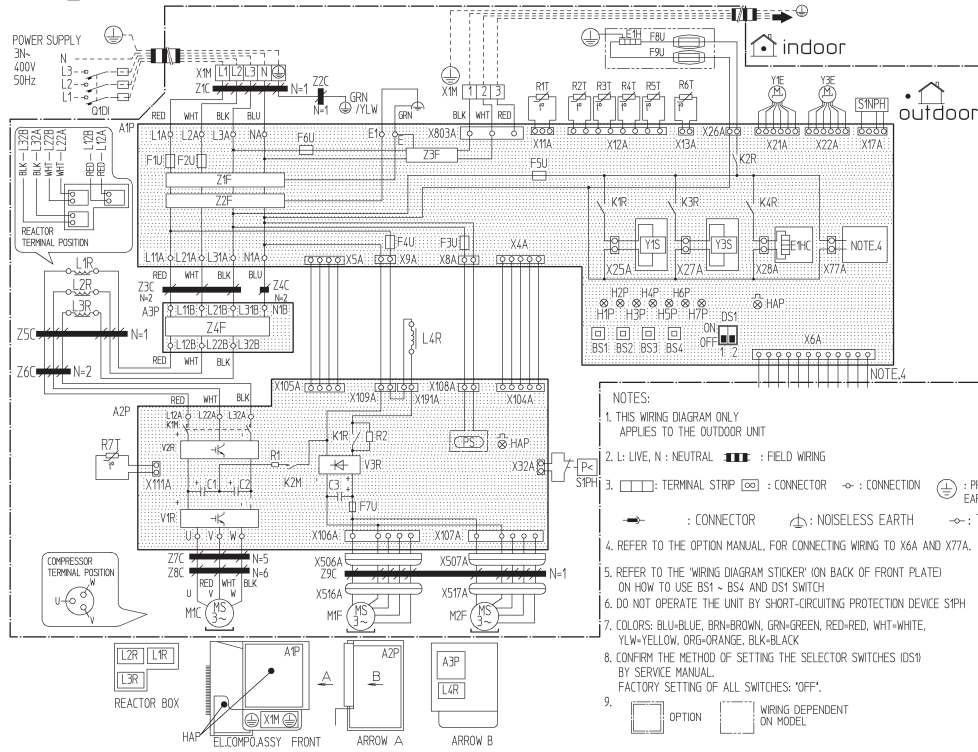

A1P	PRINTED CIRCUIT BOARD (CONTROL)
A2P	PRINTED CIRCUIT BOARD (INV.)
A3P	PRINTED CIRCUIT BOARD (NOISE FILTER)
BS1~BS4	PUSH BUTTON SWITCH
C1~C4	CAPACITOR
DS1	DIP SWITCH
E1HC	CRANKCASE HEATER
E1H	BOTTOM PLATE HEATER
F1U	FUSE (31.5A / 500V)
F2U	FUSE (31.5A / 500V)
F3U	FUSE (T 6.3A / 250V)
F4U	FUSE (T 6.3A / 250V)
F5U	FUSE (T 6.3A / 250V)
F6U	FUSE (T 6.3A / 250V)
F7U	FUSE (T 5.0A / 250V)
F8U, F9U	FUSE (F 1.0A / 250V)
HAP (A1P)	PILOT LAMP (SERVICE MONITOR-GREEN)
HAP (A2P)	PILOT LAMP (SERVICE MONITOR-GREEN)
H1P~H7P (A1P)	PILOT LAMP (SERVICE MONITOR-ORANGE)
K1M ~ K2M	MAGNETIC CONTACTOR (MAIN - UP/LOAD)
K1R (A1P)	MAGNETIC RELAY (Y1S)
K1R (A2P)	MAGNETIC RELAY (UP/LOAD)
K2R (A1P)	MAGNETIC RELAY (E9H)
K3R (A1P)	MAGNETIC RELAY (Y3S)
K4R (A1P)	MAGNETIC RELAY (E9HC)
L1R ~ L3R	REACTOR
L4R	REACTOR (FOR OUTDOOR FAN MOTOR)
M1C	MOTOR (COMPRESSOR)
M1F	MOTOR (FAN) (UPPER)
M2F	MOTOR (FAN) (LOWER)
PS	SWITCHING POWER SUPPLY
R1 ~ R4	RESISTOR
R1T	THERMISTOR (AIR)
R2T	THERMISTOR (DISCHARGE)
R3T	THERMISTOR (ISCUCTION)
R4T	THERMISTOR (HEAT EXCHANGER)
R5T	THERMISTOR (HEAT EXCHANGER MIDDLE)
R6T	THERMISTOR (LIQUID)
R7T	THERMISTOR (FAN)
S1PH	PRESSURE SENSOR
S1PH	PRESSURE SWITCH (HIGH)
V1R ~ V2R	POWER MODULE
V3R	DIODE MODULE
X1M	TERMINAL STRIP
Y1E	ELECTRONIC EXPANSION VALVE (MAIN)
Y3E	ELECTRONIC EXPANSION VALVE (BU)
Y1S	SOLENOID VALVE (4 WAY VALVE)
Y3S	SOLENOID VALVE (HOT GAS PASS)
Z1C~Z9C	NOISE FILTER
Z1F~Z4F	NOISE FILTER
OPTION	OPTIONAL COMPONENT
X6A	CONNECTOR
X77A	CONNECTOR

- NOTES:**
1. THIS WIRING DIAGRAM ONLY APPLIES TO THE OUTDOOR UNIT
 2. L: LIVE, N: NEUTRAL : FIELD WIRING
 3. : TERMINAL STRIP : CONNECTOR : CONNECTION : PROTECTIVE EARTH (SCREW)
 4. REFER TO THE OPTION MANUAL, FOR CONNECTING WIRING TO X6A AND X77A.
 5. REFER TO THE 'WIRING DIAGRAM STICKER' (ON BACK OF FRONT PLATE) ON HOW TO USE BS1 - BS4 AND DS1 SWITCH
 6. DO NOT OPERATE THE UNIT BY SHORT-CIRCUITING PROTECTION DEVICE S1PH.
 7. COLORS: BLU-BLUE, BRN-BROWN, GRN-GREEN, RED-RED, WHT-WHITE, YLW-YELLOW, ORG-ORANGE, BLK-BLACK
 8. CONFIRM THE METHOD OF SETTING THE SELECTOR SWITCHES (DS1) BY SERVICE MANUAL. FACTORY SETTING OF ALL SWITCHES: 'OFF'.
 9. : OPTION : WIRING DEPENDENT ON MODEL

Notes:

- 1 This wiring diagram applies only to the outdoor unit.
- 2 Symbols (see below).
- 3 Symbols (see below).
- 4 Refer to the option manual for connecting wiring to X6A and X77A.
- 5 Refer to the wiring diagram sticker (on the back of the service cover) for how to use the BS1~BS4 and DS1 switches.
- 6 When operating, do not short-circuit protective device S1PH.
- 7 Colours (see below).
- 8 Refer to the service manual for instructions on how to set the selector switches (DS1). The factory setting of all switches is OFF.
- 9 Symbols (see below).

Symbols:

- L Live
- N Neutral
- Field wiring
- Terminal strip
- Connector
- Connector
- Connection
- Protective earth (screw)
- Noiseless earth
- Terminal
- Option
- Wiring dependent on model

Colours:

- BLK Black
- BLU Blue
- BRN Brown

- GRN Green
- ORG Orange
- RED Red
- WHT White
- YLW Yellow

Legend:

- A1P Printed circuit board (control)
- A2P Printed circuit board (inverter)
- A3P Printed circuit board (noise filter)
- BS1~BS4 Push button switch
- C1~C4 Capacitor
- DS1 DIP switch
- E1H Bottom plate heater
- E1HC Crankcase heater
- F1U Fuse (31.5 A / 500 V)
- F2U Fuse (31.5 A / 500 V)
- F3U Fuse (T 6.3 A / 250 V)
- F4U Fuse (T 6.3 A / 250 V)
- F5U Fuse (T 6.3 A / 250 V)
- F6U Fuse (T 6.3 A / 250 V)
- F7U Fuse (T 5.0 A / 250 V)
- F8U, F9U Fuse (F 1.0 A / 250 V)
- HAP (A1P) Light-emitting diode (service monitor green)
- HAP (A2P) Light-emitting diode (service monitor green)
- H1P~H7P (A1P) Light-emitting diode (service monitor orange)
- K1M, K2M Magnetic contactor (main, upload)
- K1R (A1P) Magnetic relay (Y1S)
- K1R (A2P) Magnetic relay (upload)

2TW60336-1-

K2R (A1P)	Magnetic relay (E1H)
K3R (A1P)	Magnetic relay (Y3S)
K4R (A1P)	Magnetic relay (E1HC)
L1R~L3R	Reactor
L4R	Reactor (for outdoor fan motor)
M1C	Motor (compressor)
M1F	Motor (upper fan)
M2F	Motor (lower fan)
PS	Switching power supply
Q1DI	Earth leakage circuit breaker (field supply)
R1~R4	Resistor
R1T	Thermistor (air)
R2T	Thermistor (discharge)
R3T	Thermistor (suction)
R4T	Thermistor (heat exchanger)
R5T	Thermistor (heat exchanger middle)
R6T	Thermistor (liquid)
R7T	Thermistor (fin)
S1NPH	Pressure sensor
S1PH	High pressure switch
V1R, V2R	Power module
V3R	Diode module
X1M	Terminal strip (power supply)
X6A	Connector (option)
X77A	Connector (option)
Y1E	Electronic expansion valve (main)
Y3E	Electronic expansion valve (injection)
Y1S	Solenoid valve (4-way valve)
Y3S	Solenoid valve (hot gas pass)
Z1C~Z9C	Noise filter
Z1F~Z4F	Noise filter

14 Technical data

14.6.2 Wiring diagram: Indoor unit

See the internal wiring diagram supplied with the unit (on the inside of the indoor unit switch box cover). The abbreviations used are listed below.

Position in switch box

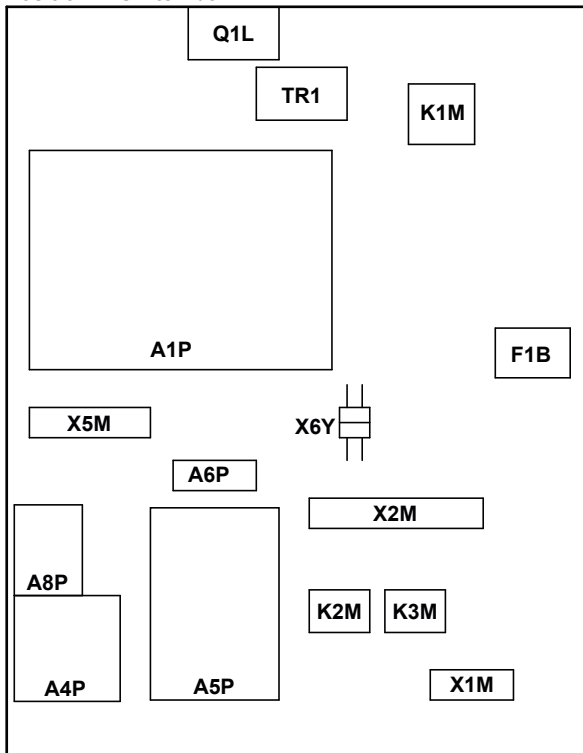

User installed options:

- Bottom plate heater
- Remote user interface
- External indoor thermistor
- External outdoor thermistor
- Digital I/O PCB
- Demand PCB

Main leaving water temperature:

- On/OFF thermostat (wired)
- On/OFF thermostat (wireless)
- External thermistor on On/OFF thermostat (wireless)
- Heat pump convector
- Safety thermostat

Additional leaving water temperature:



- On/OFF thermostat (wired)
- On/OFF thermostat (wireless)
- External thermistor on On/OFF thermostat (wireless)
- Heat pump convector

14 Technical data

A1P	Main PCB
A2P	User interface PCB
A3P	* On/OFF thermostat (PC=power circuit)
A3P	* Heat pump convector
A4P	* Digital I/O PCB
A4P	* Receiver PCB (Wireless On/OFF thermostat)
A5P	Bizone PCB
A6P	Current loop PCB
A8P	* Demand PCB
B1L	Flow sensor
DS1 (A5P)	* DIP switch
DS1 (A8P)	* DIP switch
E3H	Backup heater element (3 kW)
F1B	Overcurrent fuse backup heater
F1T	Thermal fuse backup heater
F1U (A4P)	* Fuse 5 A 250 V for digital I/O PCB
F2U (A4P)	* Fuse 5 A 250 V for digital I/O PCB
F1U (A5P)	Fuse T 2 A 250 V for PCB
F2U (A5P)	Fuse T 2 A 250 V for PCB
FU1 (A1P)	Fuse T 6.3 A 250 V for PCB
FU2 (A1P)	Fuse T 6.3 A 250 V for PCB
K1M	Contacteur backup heater
K2M	Relay 3-way valve bypass
K3M	Relay 3-way valve flow
K*R	Relay on PCB
M1P	Additional zone pump
M2P	# Domestic hot water pump
M3P	Main zone pump
M1S	Mixing 3-way valve
M2S	# 2-way valve for cooling mode
M3S	3-way valve for space heating/domestic hot water
PHC1	* Optocoupler input circuit
Q1DI, Q2DI	# Earth leakage circuit breaker
Q1L	Thermal protector backup heater
Q3L	# Safety thermostat
R1T (A1P)	Outlet water heat exchanger thermistor
R1T (A2P)	Ambient sensor user interface

R1T (A3P)	* Ambient sensor On/OFF thermostat
R2T (A1P)	Outlet backup heater thermistor
R2T (A3P)	* External sensor (floor or ambient)
R3T (A1P)	Refrigerant liquid side thermistor
R4T (A1P)	Inlet water thermistor
R5T (A1P)	Domestic hot water thermistor
R6T (A1P)	* External indoor or outdoor ambient thermistor
R7T (A5P)	Mixed leaving water thermistor
R1H (A3P)	* Humidity sensor
S1S	# Preferential kWh rate power supply contact
S2S	# Electrical meter pulse input 1
S3S	# Electrical meter pulse input 2
S6S~S9S	# Digital power limitation inputs
SS1 (A4P)	* Selector switch
TR1	Power supply transformer
X*M	Terminal strip
X*Y	Connector
	* = Optional
	# = Field supply
BLK	Black
BRN	Brown
GRY	Grey
RED	Red

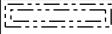
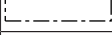
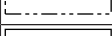
Notes to go through before starting the unit

English	Translation
X1M	Main terminal
X2M	Field wiring terminal for AC
X5M	Field wiring terminal for DC
-----	Earth wiring
15	Wire number 15
-----	Field supply
—> **/12.2	Connection ** continues on page 12 column 2
①	Several wiring possibilities
	Option
	Not mounted in switch box
	Wiring depending on model
	PCB

Electrical connection diagram

For more details, please check the unit wiring.

Power supply

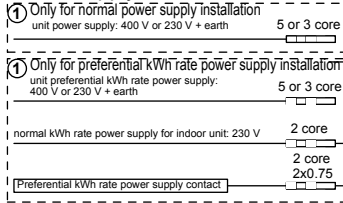

Standard part

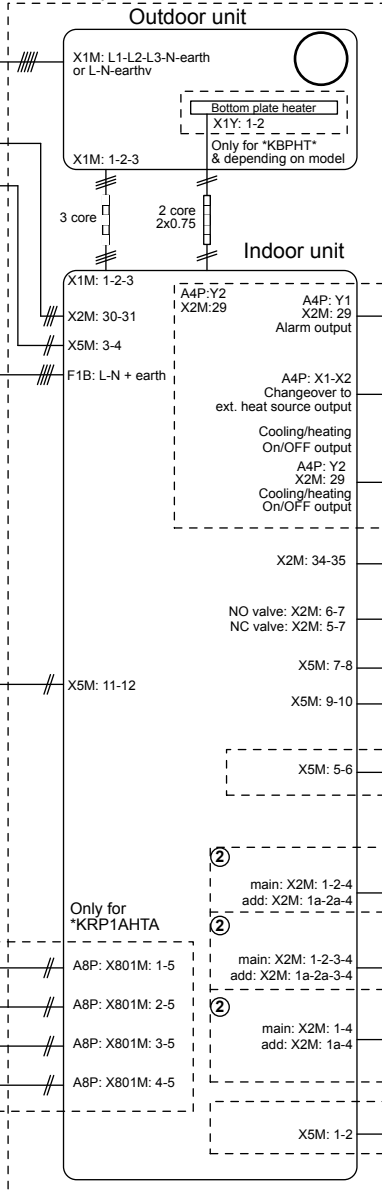

Note

In case of signal cable: keep minimum distance
to power cables >5 cm

Field supply

Only for *KRP1HB*

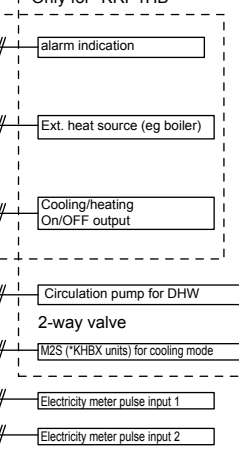

Only for KRCS01-1 or EKRSCA1

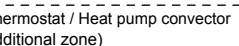

External room thermostat / Heat pump convector
(main and/or additional zone)

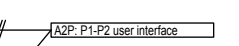
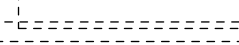
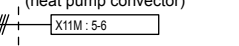
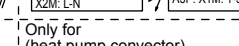
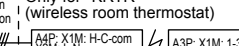
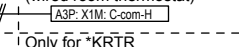

Field supply

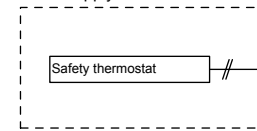

Field supply

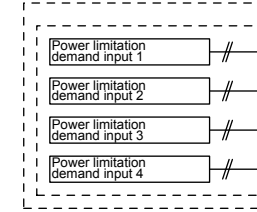

4D096036-1

14 Technical data

Electrical meter specification

- Pulse meter type/voltage-free contact for 5 V DC detection by PCB.
- Possible numbers of pulses
 - 0.1 pulse/kWh
 - 1 pulse/kWh
 - 10 pulse/kWh
 - 100 pulse/kWh
 - 1000 pulse/kWh
- Pulse duration
 - minimum On time: 40 ms
 - minimum OFF time: 100 ms
- Measurement type (depending on installation)
 - Single phase AC meter
 - Three phase AC meter: balanced loads
 - Three phase AC meter: unbalanced loads

Electrical meter installation guideline

It is the responsibility of the installer to cover the complete power consumption with electrical meters (combination of estimation and metering is NOT allowed).

Required number of electrical meters.

Outdoor unit type		ERLQ004~008CAV3	ERHQ011~016BAV3	ERHQ011~016BAW1
			ERLQ011~016CAV3	ERLQ011~016CAW1
Indoor unit type		EHVZ04+08		EHVZ16
Backup heater type		3V		
Backup heater power supply		1~ 230 V		
Backup heater configuration		3 kW		
Normal kWh rate power supply				
Electrical meter type	1~	1	1	1 / —
	3~ balanced	—	—	1 / —
	3~ unbalanced	—	—	1 / —
Preferential kWh rate power supply				
Electrical meter type	1~	2	2	1
	3~ unbalanced	—	—	1

14.7 Technical specifications

14.7.1 Technical specifications: Outdoor unit

Overview

The technical specifications are divided into the following tables:

ERHQ_V3	<ul style="list-style-type: none"> Nominal capacity and nominal input: ERHQ_V3 Technical specifications: ERHQ_V3 Electrical specifications: ERHQ_V3
ERHQ_W1	<ul style="list-style-type: none"> Nominal capacity and nominal input: ERHQ_W1 Technical specifications: ERHQ_W1 Electrical specifications: ERHQ_W1
ERLQ_V3	<ul style="list-style-type: none"> Nominal capacity and nominal input: ERLQ_V3 Technical specifications: ERLQ_V3 Electrical specifications: ERLQ_V3
ERLQ_W1	<ul style="list-style-type: none"> Nominal capacity and nominal input: ERLQ_W1 Technical specifications: ERLQ_W1 Electrical specifications: ERLQ_W1

Nominal capacity and nominal input: ERHQ_V3

Indoor units		EHVZ16		
Outdoor units		ERHQ011BAV3	ERHQ014BAV3	ERHQ016BAV3
Heating floor program^(a)				
Nominal heating	Capacity	11.2 kW	14.0 kW	16.0 kW
	Power input	2.55 kW	3.26 kW	3.92 kW
	COP	4.39	4.29	4.08
Nominal cooling	Capacity	—	—	—
	Power input	—	—	—
	EER	—	—	—
Fan coil program^(b)				
Nominal heating	Capacity	10.3 kW	13.1 kW	15.2 kW
	Power input	3.17 kW	4.04 kW	4.75 kW
	COP	3.25	3.24	3.20
Nominal cooling	Capacity	—	—	—
	Power input	—	—	—
	EER	—	—	—

(a) In heating: Ambient temperature DB/WB 7°C/6°C – leaving water condenser 35°C ($\Delta T=5^{\circ}\text{C}$). In cooling: Ambient temperature 35°C – leaving water evaporator 18°C ($\Delta T=5^{\circ}\text{C}$)

(b) In heating: Ambient temperature DB/WB 7°C/6°C – leaving water condenser 45°C ($\Delta T=5^{\circ}\text{C}$). In cooling: Ambient temperature 35°C – leaving water evaporator 7°C ($\Delta T=5^{\circ}\text{C}$)

Technical specifications: ERHQ_V3

Indoor units		EHVZ16		
Outdoor units		ERHQ011BAV3	ERHQ014BAV3	ERHQ016BAV3
Casing				
Colour	Ivory white			
Material	Painted galvanised steel plate			
Dimensions				
Packing (H×W×D)	1349×980×420 mm			
Unit (H×W×D)	1170×900×320 mm			
Weight				
Machine weight	102 kg			
Gross weight	118 kg			
Packing				
Material	EPS, carton, wood, PE (straps)			
Weight	16 kg			
Heat exchanger				

14 Technical data

Indoor units		EHVZ16			
Outdoor units		ERHQ011BAV3	ERHQ014BAV3	ERHQ016BAV3	
Specifications	Length	857 mm			
	Nr. of rows	2			
	Fin pitch	1.4 mm			
	Nr. of passes	6			
	Face area	0.98 m ²			
	Nr. of stages	52			
	Empty tube plate hole	0			
Tube type		Hi-XSS(8)			
Fin	Type	WF fin			
	Treatment	Anti-corrosion treatment (PE)			
Fan					
Type		Propeller			
Quantity		2			
Air flow rate (nominal at 230 V)	Heating	—			
	Cooling	90 m ³ /min			
Discharge direction		Horizontal			
External static pressure (maximum)		—			
Motor	Quantity	2			
	Model	Brushless DC motor			
	Position	—			
	Speed (nominal at 230 V)	Nr. of steps	8		
		Cooling	—		
		Heating	760 rpm		
	Output	70 W			
Drive	Direct drive				
Compressor					
Quantity		1			
Motor	Model	JT100G-VD			
	Type	Hermetically sealed scroll compressor			
	Speed	—			
	Output	2200 W			
	Starting method	Inverter driven			
	Crankcase heater	33 W			
Operation range^(a)					
Heating (outdoor unit) ^(b)	Minimum	-20°C DB			
	Maximum	35°C DB			
Cooling	Minimum	—			
	Maximum	—			
Domestic hot water (outdoor unit) ^(c)	Minimum	-20°C DB			
	Maximum	35°C DB			
Sound level					
Nominal – Heating	Sound power	64 dBA	64 dBA	66 dBA	
	Sound pressure ^(d)	49 dBA	51 dBA	53 dBA	
Nominal – Cooling	Sound power	—			
	Sound pressure ^(d)	—			
Night quiet - Heating	Sound pressure ^(d)	42 dBA	42 dBA	43 dBA	
Night quiet - Cooling	Sound pressure ^(d)	—			
Refrigerant					
Type		R410A			
Charge		2.7 kg			
Control		Expansion valve (electronic type)			
Nr. of circuits		1			
Refrigerant oil					

Indoor units		EHVZ16		
Outdoor units		ERHQ011BAV3	ERHQ014BAV3	ERHQ016BAV3
Type		Daphne FVC68D		
Charged volume		1.5 l		
Piping connections				
Liquid	Quantity	1		
	Type	Flare connection		
	Diameter (OD)	Ø9.52 mm		
Gas	Quantity	1		
	Type	Flare connection		
	Diameter (OD)	Ø15.9 mm		
Drain	Quantity	3		
	Type	Hole		
	Diameter (OD)	Ø26 mm		
Piping length	Minimum	3 m		
	Maximum	75 m		
	Equivalent	95 m		
	Chargeless	10 m		
Additional refrigerant charge		See "To determine the additional refrigerant amount"		
Maximum height difference between outdoor unit and indoor unit		30 m		
Equivalent height difference		—		
Maximum interunit level difference		—		
Heat insulation		Both liquid and gas pipe		
Defrost method		Pressure equalising		
Defrost control		Sensor for outdoor heat exchanger temperature		
Capacity control method		Inverter controlled		
Capacity control (%)		—		
Safety devices		High pressure switch / Fan motor thermal protector / Fuse		
Standard accessories		1 installation manual / 2 tie wraps		

- (a) See operation range drawing.
(b) Range increase by support backup heater.
(c) Range increase by support booster heater.
(d) The sound pressure level is measured via a microphone at a certain distance from the unit. It is a relative value depending on the distance and acoustic environment. Refer to the sound spectrum drawing for more information.

Electrical specifications: ERHQ_V3

Indoor units		Heating only type		
Outdoor units		ERHQ011BAV3	ERHQ014BAV3	ERHQ016BAV3
Power supply				
Name		V3		
Phase		1~		
Frequency		50 Hz		
Voltage		230 V		
Voltage range	Minimum	207 V		
	Maximum	253 V		
Current				
Nominal running current		—		
Starting current		—	—	—
Maximum running current	Cooling	—		
	Heating	—		
Z _{max}		—		
Minimum S _{sc} value		Equipment complying with EN/IEC 61000-3-12 ^(a)		
Recommended fuses		32 A		
Wiring connections				
For power supply		See "Connecting electrical wiring"		
For connection with indoor				

14 Technical data

	Heating only type		
Indoor units	EHVZ16		
Outdoor units	ERHQ011BAV3	ERHQ014BAV3	ERHQ016BAV3
Power supply intake	Outdoor unit only		

- (a) European/International Technical Standard setting the limits for harmonic currents produced by equipment connected to public low-voltage systems with input current >16 A and ≤75 A per phase.

Nominal capacity and nominal input: ERHQ_W1

Indoor units		EHVZ16		
Outdoor units		ERHQ011BAW1	ERHQ014BAW1	ERHQ016BAW1
Cooling and heating floor program^(a)				
Nominal heating	Capacity	11.32 kW	14.50 kW	16.05 kW
	Power input	2.63 kW	3.42 kW	3.82 kW
	COP	4.30	4.24	4.20
Nominal cooling	Capacity	—	—	—
	Power input	—	—	—
	EER	—	—	—
Fan coil program^(b)				
Nominal heating	Capacity	10.98 kW	13.57 kW	15.11 kW
	Power input	3.24 kW	4.21 kW	4.69 kW
	COP	3.39	3.22	3.22
Nominal cooling	Capacity	—	—	—
	Power input	—	—	—
	EER	—	—	—

(a) In heating: Ambient temperature DB/WB 7°C/6°C – leaving water condenser 35°C ($\Delta T=5^{\circ}\text{C}$). In cooling: Ambient temperature 35°C – leaving water evaporator 18°C ($\Delta T=5^{\circ}\text{C}$)

(b) In heating: Ambient temperature DB/WB 7°C/6°C – leaving water condenser 45°C ($\Delta T=5^{\circ}\text{C}$). In cooling: Ambient temperature 35°C – leaving water evaporator 7°C ($\Delta T=5^{\circ}\text{C}$)

Technical specifications: ERHQ_W1

Indoor units		EHVZ16		
Outdoor units		ERHQ011BAW1	ERHQ014BAW1	ERHQ016BAW1
Casing				
Colour		Ivory white		
Material		Painted galvanised steel plate		
Dimensions				
Packing (H×W×D)		1524×980×420 mm		
Unit (H×W×D)		1345×900×320 mm		
Weight				
Machine weight		108 kg		
Gross weight		123 kg		
Packing				
Material		EPS, carton, wood, PE (straps)		
Weight		15 kg		
Heat exchanger				
Specifications	Length	857 mm		
	Nr. of rows	2		
	Fin pitch	1.4 mm		
	Nr. of passes	5		
	Face area	1.131 m ²		
	Nr. of stages	60		
	Empty tube plate hole	0		
Tube type		Hi-XSS(8)		
Fin	Type	WF fin		
	Treatment	Anti-corrosion treatment (PE)		
Fan				
Type		Propeller		
Quantity		2		
Air flow rate (nominal at 230 V)		—		
Discharge direction		Horizontal		
External static pressure (maximum)		—		

14 Technical data

Indoor units		EHVZ16			
Outdoor units		ERHQ011BAW1	ERHQ014BAW1	ERHQ016BAW1	
Motor	Quantity	2			
	Model	Brushless DC motor			
	Position	—			
	Speed (nominal at 230 V)	Nr. of steps	8		
		Cooling	—		
		Heating	760 rpm		
	Output	70 W			
Drive	Direct drive				
Compressor					
Quantity		1			
Motor	Model	JT1G-VDYR@S			
	Type	Hermetically sealed scroll compressor			
	Speed	—			
	Output	2200 W			
	Starting method	Inverter driven			
	Crankcase heater	33 W			
Operation range^(a)					
Heating (outdoor unit) ^(b)	Minimum	-25°C DB			
	Maximum	35°C DB			
Cooling	Minimum	—			
	Maximum	—			
Domestic hot water (outdoor unit) ^(c)	Minimum	-20°C DB			
	Maximum	35°C DB			
Sound level					
Nominal – Heating ^(d)	Sound power	64 dBA	64 dBA	66 dBA	
	Sound pressure ^(f)	51 dBA	51 dBA	52 dBA	
Nominal – Cooling ^(e)	Sound power	—			
	Sound pressure ^(f)	—			
Night quiet - Heating	Sound pressure ^(f)	42 dBA	42 dBA	43 dBA	
Night quiet - Cooling	Sound pressure ^(f)	—			
Refrigerant					
Type		R410A			
Charge		2.95 kg			
Control		Expansion valve (electronic type)			
Nr. of circuits		1			
Refrigerant oil					
Type		Daphne FVC68D			
Charged volume		1.0 l			
Piping connections					
Liquid	Quantity	1			
	Type	Flare connection			
	Diameter (OD)	Ø9.52 mm			
Gas	Quantity	1			
	Type	Flare connection			
	Diameter (OD)	Ø15.9 mm			
Drain	Quantity	4			
	Type	Hole			
	Diameter (OD)	3× Ø26+1× Ø18 mm			
Piping length	Minimum	3 m			
	Maximum	75 m			
	Equivalent	95 m			
	Chargeless	10 m			
Additional refrigerant charge		See "To determine the additional refrigerant amount"			

Indoor units	EHVZ16		
Outdoor units	ERHQ011BAW1	ERHQ014BAW1	ERHQ016BAW1
Maximum height difference between outdoor unit and indoor unit	30 m		
Equivalent height difference	—		
Maximum interunit level difference	—		
Heat insulation	Both liquid and gas pipe		
Defrost method	Pressure equalising		
Defrost control	Sensor for outdoor heat exchanger temperature		
Capacity control method	Inverter controlled		
Capacity control (%)	—		
Safety devices	High pressure switch / Fan motor thermal protector / Fuse		
Standard accessories	1 installation manual / 2 tie wraps		

- (a) See operation range drawing.
 (b) Range increase by support backup heater.
 (c) Range increase by support booster heater.
 (d) Ambient temperature DB/WB 7°C/6°C – leaving water condenser 35°C ($\Delta T=5^{\circ}\text{C}$).
 (e) Ambient temperature 35°C – leaving water evaporator 7°C ($\Delta T=5^{\circ}\text{C}$)
 (f) The sound pressure level is measured via a microphone at a certain distance from the unit. It is a relative value depending on the distance and acoustic environment. Refer to the sound spectrum drawing for more information.

Electrical specifications: ERHQ_W1

Indoor units	EHVZ16		
Outdoor units	ERHQ011BAW1	ERHQ014BAW1	ERHQ016BAW1
Power supply			
Name	W1		
Phase	3N~		
Frequency	50 Hz		
Voltage	400 V		
Voltage range	Minimum	360 V	
	Maximum	440 V	
Current			
Nominal running current	Cooling	—	
	Heating ^(a)	5.8 A	
Starting current	—		
Maximum running current (cooling and heating)	13.5 A		
Z_{max}	—		
Minimum S_{sc} value	—		
Recommended fuses	20 A		
Wiring connections			
For power supply	See "Connecting electrical wiring"		
For connection with indoor			
Power supply intake	Outdoor unit only		

- (a) Ambient temperature DB/WB 7°C/6°C – leaving water condenser 35°C ($\Delta T=5^{\circ}\text{C}$).

14 Technical data

Nominal capacity and nominal input: ERLQ_V3

Indoor units		EHVZ16		
Outdoor units		ERLQ011CAV3	ERLQ014CAV3	ERLQ016CAV3
Heating floor program				
Nominal heating ^(a)	Capacity	11.2 kW	14.5 kW	16 kW
	Power input	2.43 kW	3.37 kW	3.76 kW
	COP	4.6	4.3	4.25
Maximum heating ^(c)	Capacity	8.6 kW	10.6 kW	11.4 kW
	Power input	3.13 kW	4.00 kW	4.32 kW
	COP	2.75	2.65	2.64
Nominal cooling ^(a)	Capacity	—		
	Power input	—		
	EER	—		
Fan coil program				
Nominal heating ^(b)	Capacity	11.00 kW	13.60 kW	15.20 kW
	Power input	3.10 kW	4.10 kW	4.66 kW
	COP	3.55	3.32	3.26
Maximum heating ^(d)	Capacity	8.60 kW	10.80 kW	10.90 kW
	Power input	4.10 kW	5.19 kW	5.22 kW
	COP	2.10	2.08	2.09
Nominal cooling ^(b)	Capacity	—		
	Power input	—		
	EER	—		

(a) In heating: Ambient temperature DB/WB 7°C/6°C – leaving water condenser 35°C (ΔT=5°C). In cooling: Ambient temperature 35°C – leaving water evaporator 18°C (ΔT=5°C)

(b) In heating: Ambient temperature DB/WB 7°C/6°C – leaving water condenser 45°C (ΔT=5°C). In cooling: Ambient temperature 35°C – leaving water evaporator 7°C (ΔT=5°C)

(c) In heating: Ambient temperature DB –7°C (RH 85%) – leaving water condenser 35°C.

(d) In heating: Ambient temperature DB –7°C (RH 85%) – leaving water condenser 45°C.

Technical specifications: ERLQ_V3

Indoor units		EHVZ16		
Outdoor units		ERLQ011CAV3	ERLQ014CAV3	ERLQ016CAV3
Casing				
Colour		Ivory white		
Material		Painted galvanised steel plate		
Dimensions				
Packing (H×W×D)		1524×980×420 mm		
Unit (H×W×D)		1345×900×320 mm		
Weight				
Machine weight		113 kg		
Gross weight		128 kg		
Packing				
Material		EPS, carton, wood, PE (straps)		
Weight		15 kg		
Heat exchanger				
Specifications	Length	857 mm		
	Nr. of rows	2		
	Fin pitch	1.4 mm		
	Nr. of passes	7		
	Face area	1.131 m ²		
	Nr. of stages	60		
Empty tube plate hole		0		
Tube type		Hi-XSS(8)		
Fin	Type	WF fin		
	Treatment	Anti-corrosion treatment (PE)		
Fan				

Indoor units		EHVZ16			
Outdoor units		ERLQ011CAV3	ERLQ014CAV3	ERLQ016CAV3	
Type		Propeller			
Quantity		2			
Air flow rate (nominal at 230 V)		—			
Discharge direction		Horizontal			
External static pressure (maximum)		—			
Motor	Quantity	2			
	Model	Brushless DC motor			
	Position	—			
	Speed (nominal at 230 V)	Nr. of steps	8		
		Cooling	—		
		Heating	740 rpm	750 rpm	760 rpm
Output	70 W				
Drive	Direct drive				
Compressor					
Quantity		1			
Motor	Model	JT100G-VD@B2			
	Type	Hermetically sealed scroll compressor			
	Speed	—			
	Output	2200 W			
	Starting method	Inverter driven			
	Crankcase heater	33 W			
Operation range^(a)					
Heating (outdoor unit) ^(b)	Minimum	-25°C DB			
	Maximum	35°C DB			
Cooling	Minimum	—			
	Maximum	—			
Domestic hot water (outdoor unit) ^(c)	Minimum	-20°C DB			
	Maximum	35°C DB			
Sound level					
Nominal – Heating ^(d)	Sound power	64 dBA	64 dBA	66 dBA	
	Sound pressure ^(f)	51 dBA	51 dBA	52 dBA	
Nominal – Cooling ^(e)	Sound power	—			
	Sound pressure ^(f)	—			
Night quiet - Heating	Sound pressure ^(f)	42 dBA	42 dBA	43 dBA	
Night quiet - Cooling	Sound pressure ^(f)	—			
Refrigerant					
Type		R410A			
Charge		3.4 kg			
Control		Expansion valve (electronic type)			
Nr. of circuits		1			
Refrigerant oil					
Type		Daphne FVC68D			
Charged volume		1.5 l			
Piping connections					
Liquid	Quantity	1			
	Type	Flare connection			
	Diameter (OD)	Ø9.52 mm			
Gas	Quantity	1			
	Type	Flare connection			
	Diameter (OD)	Ø15.9 mm			
Drain	Quantity	5			
	Type	Hole			
	Diameter (OD)	5× Ø26 mm			

14 Technical data

Indoor units		EHVZ16		
Outdoor units		ERLQ011CAV3	ERLQ014CAV3	ERLQ016CAV3
Piping length	Minimum	3 m		
	Maximum	50 m		
	Equivalent	70 m		
	Chargeless	10 m		
Additional refrigerant charge		See "To determine the additional refrigerant amount"		
Maximum height difference between outdoor unit and indoor unit		30 m		
Equivalent height difference		—		
Maximum interunit level difference		—		
Heat insulation		Both liquid and gas pipe		
Defrost method		Pressure equalising		
Defrost control		Sensor for outdoor heat exchanger temperature		
Capacity control method		Inverter controlled		
Capacity control (%)		—		
Safety devices		High pressure switch / Fan motor thermal protector / Fuse		
Standard accessories		1 installation manual / 2 tie wraps		

- (a) See operation range drawing.
- (b) Range increase by support backup heater.
- (c) Range increase by support booster heater.
- (d) Ambient temperature DB/WB 7°C/6°C – leaving water condenser 35°C ($\Delta T=5^{\circ}\text{C}$).
- (e) Ambient temperature 35°C – leaving water evaporator 7°C ($\Delta T=5^{\circ}\text{C}$)
- (f) The sound pressure level is measured via a microphone at a certain distance from the unit. It is a relative value depending on the distance and acoustic environment. Refer to the sound spectrum drawing for more information.

Electrical specifications: ERLQ_V3

Indoor units		EHVZ16		
Outdoor units		ERLQ011CAV3	ERLQ014CAV3	ERLQ016CAV3
Power supply				
Name		V3		
Phase		1~		
Frequency		50 Hz		
Voltage		230 V		
Voltage range	Minimum	207 V		
	Maximum	253 V		
Current				
Nominal running current		—		
Starting current		—		
Maximum running current (cooling and heating)		34.2 A		
Z_{max}		0.22 $\Omega^{(a)}$		
Minimum S_{sc} value		525 kVA ^(a)		
Recommended fuses		40 A		
Wiring connections				
For power supply		See "Connecting electrical wiring"		
For connection with indoor				
Power supply intake		Outdoor unit only		

(a) This equipment complies with:

- **EN/IEC 61000-3-11** provided that the system impedance Z_{sys} is less than or equal to Z_{max} at the interface point between the user's supply and the public system.
 - EN/IEC 61000-3-11 = European/International Technical Standard setting the limits for voltage changes, voltage fluctuations and flicker in public low-voltage supply systems for equipment with rated current ≤ 75 A.
 - It is the responsibility of the installer or user of the equipment to ensure, by consultation with the distribution network operator if necessary, that the equipment is connected only to a supply with a system impedance Z_{sys} less than or equal to Z_{max} .
- **EN/IEC 61000-3-12** provided that the short-circuit power S_{sc} is greater than or equal to the minimum S_{sc} value at the interface point between the user's supply and the public system.
 - EN/IEC 61000-3-12 = European/International Technical Standard setting the limits for harmonic currents produced by equipment connected to public low-voltage systems with input current > 16 A and ≤ 75 A per phase.
 - It is the responsibility of the installer or user of the equipment to ensure, by consultation with the distribution network operator if necessary, that the equipment is connected only to a supply with a short-circuit power S_{sc} greater than or equal to the minimum S_{sc} value.

14 Technical data

Nominal capacity and nominal input: ERLQ_W1

Indoor units		EHVZ16		
Outdoor units		ERLQ011CAW1	ERLQ014CAW1	ERLQ016CAW1
Heating floor program				
Nominal heating ^(a)	Capacity	11.2 kW	14.5 kW	16 kW
	Power input	2.43 kW	3.37 kW	3.76 kW
	COP	4.6	4.3	4.25
Maximum heating ^(c)	Capacity	8.6 kW	10.6 kW	11.4 kW
	Power input	3.13 kW	4.00 kW	4.32 kW
	COP	2.75	2.65	2.64
Nominal cooling ^(a)	Capacity	—		
	Power input	—		
	EER	—		
Fan coil program				
Nominal heating ^(b)	Capacity	11.00 kW	13.60 kW	15.20 kW
	Power input	3.10 kW	4.10 kW	4.66 kW
	COP	3.55	3.32	3.26
Maximum heating ^(d)	Capacity	8.60 kW	10.80 kW	10.90 kW
	Power input	4.10 kW	5.19 kW	5.22 kW
	COP	2.10	2.08	2.09
Nominal cooling ^(b)	Capacity	—		
	Power input	—		
	EER	—		

(a) In heating: Ambient temperature DB/WB 7°C/6°C – leaving water condenser 35°C (ΔT=5°C). In cooling: Ambient temperature 35°C – leaving water evaporator 18°C (ΔT=5°C)

(b) In heating: Ambient temperature DB/WB 7°C/6°C – leaving water condenser 45°C (ΔT=5°C). In cooling: Ambient temperature 35°C – leaving water evaporator 7°C (ΔT=5°C)

(c) In heating: Ambient temperature DB –7°C (RH 85%) – leaving water condenser 35°C.

(d) In heating: Ambient temperature DB –7°C (RH 85%) – leaving water condenser 45°C.

Technical specifications: ERLQ_W1

Indoor units		EHVZ16		
Outdoor units		ERLQ011CAW1	ERLQ014CAW1	ERLQ016CAW1
Casing				
Colour		Ivory white		
Material		Painted galvanised steel plate		
Dimensions				
Packing (H×W×D)		1524×980×420 mm		
Unit (H×W×D)		1345×900×320 mm		
Weight				
Machine weight		114 kg		
Gross weight		129 kg		
Packing				
Material		EPS, carton, wood, PE (straps)		
Weight		15 kg		
Heat exchanger				
Specifications	Length	857 mm		
	Nr. of rows	2		
	Fin pitch	1.4 mm		
	Nr. of passes	7		
	Face area	1.131 m ²		
	Nr. of stages	60		
Empty tube plate hole		0		
Tube type		Hi-XSS(8)		
Fin	Type	WF fin		
	Treatment	Anti-corrosion treatment (PE)		
Fan				

Indoor units		EHVZ16			
Outdoor units		ERLQ011CAW1	ERLQ014CAW1	ERLQ016CAW1	
Type		Propeller			
Quantity		2			
Air flow rate (nominal at 230 V)		—			
Discharge direction		Horizontal			
External static pressure (maximum)		—			
Motor	Quantity	2			
	Model	Brushless DC motor			
	Position	—			
	Speed (nominal at 230 V)	Nr. of steps	8		
		Cooling	—		
	Heating	740 rpm	750 rpm	760 rpm	
Output	70 W				
Drive	Direct drive				
Compressor					
Quantity		1			
Motor	Model	JT1G-VDYR@B2			
	Type	Hermetically sealed scroll compressor			
	Speed	—			
	Output	2200 W			
	Starting method	Inverter driven			
	Crankcase heater	33 W			
Operation range^(a)					
Heating (outdoor unit) ^(b)	Minimum	-25°C DB			
	Maximum	35°C DB			
Cooling	Minimum	—			
	Maximum	—			
Domestic hot water (outdoor unit) ^(c)	Minimum	-20°C DB			
	Maximum	35°C DB			
Sound level					
Nominal – Heating ^(d)	Sound power	64 dBA	64 dBA	66 dBA	
	Sound pressure ^(f)	51 dBA	51 dBA	52 dBA	
Nominal – Cooling ^(e)	Sound power	—			
	Sound pressure ^(f)	—			
Night quiet - Heating	Sound pressure ^(f)	42 dBA	42 dBA	43 dBA	
Night quiet - Cooling	Sound pressure ^(f)	—			
Refrigerant					
Type		R410A			
Charge		3.4 kg			
Control		Expansion valve (electronic type)			
Nr. of circuits		1			
Refrigerant oil					
Type		Daphne FVC68D			
Charged volume		1.5 l			
Piping connections					
Liquid	Quantity	1			
	Type	Flare connection			
	Diameter (OD)	Ø9.52 mm			
Gas	Quantity	1			
	Type	Flare connection			
	Diameter (OD)	Ø15.9 mm			
Drain	Quantity	5			
	Type	Hole			
	Diameter (OD)	5× Ø26 mm			

14 Technical data

Indoor units		EHVZ16		
Outdoor units		ERLQ011CAW1	ERLQ014CAW1	ERLQ016CAW1
Piping length	Minimum	3 m		
	Maximum	50 m		
	Equivalent	70 m		
	Chargeless	10 m		
Additional refrigerant charge		See "To determine the additional refrigerant amount"		
Maximum height difference between outdoor unit and indoor unit		30 m		
Equivalent height difference		—		
Maximum interunit level difference		—		
Heat insulation		Both liquid and gas pipe		
Defrost method		Pressure equalising		
Defrost control		Sensor for outdoor heat exchanger temperature		
Capacity control method		Inverter controlled		
Capacity control (%)		—		
Safety devices		High pressure switch / Fan motor thermal protector / Fuse		
Standard accessories		1 installation manual / 2 tie wraps		

- (a) See operation range drawing.
- (b) Range increase by support backup heater.
- (c) Range increase by support booster heater.
- (d) Ambient temperature DB/WB 7°C/6°C – leaving water condenser 35°C ($\Delta T=5^{\circ}\text{C}$).
- (e) Ambient temperature 35°C – leaving water evaporator 7°C ($\Delta T=5^{\circ}\text{C}$)
- (f) The sound pressure level is measured via a microphone at a certain distance from the unit. It is a relative value depending on the distance and acoustic environment. Refer to the sound spectrum drawing for more information.

Electrical specifications: ERLQ_W1

Indoor units		EHVZ16		
Outdoor units		ERLQ011CAW1	ERLQ014CAW1	ERLQ016CAW1
Power supply				
Name		W1		
Phase		3N~		
Frequency		50 Hz		
Voltage		400 V		
Voltage range	Minimum	360 V		
	Maximum	440 V		
Current				
Nominal running current		—		
Starting current		—		
Maximum running current (cooling and heating)		16.3 A		
Z_{max}		—		
Minimum S_{sc} value		Equipment complying with EN/IEC 61000-3-12 ^(a)		
Recommended fuses		20 A		
Wiring connections				
For power supply		See "Connecting electrical wiring" Outdoor unit only		
For connection with indoor				
Power supply intake				

- (a) European/International Technical Standard setting the limits for harmonic currents produced by equipment connected to public low-voltage systems with input current $>16\text{ A}$ and $\leq 75\text{ A}$ per phase.

14.7.2 Technical specifications: Indoor unit

Technical specifications

Indoor units		EHVZ16S18CB3V
Heater capacity	Step 1	3 kW
Power input	Nominal	0.20 kW
Casing		
Colour		White
Material		Pre-coated sheet metal
Dimensions		
Unit (H×W×D)		1732×600×728 mm
Packed unit (H×W×D)		1922×690×818 mm
Weight		
Unit		121 kg
Packed unit		138 kg
Packing		
Material		Wood – carton – PE wrapping foil
Weight		17 kg
PED		
Category		Art. 3.3§3 ⁽¹⁾
Water side heat exchanger		
Type		Brazed plate
Quantity		1
Water volume		1 l
Water flow rate	Minimum	16.0 l/min ⁽²⁾
	Heating (nominal)	46.0 l/min
Pump main zone		
Type		DC motor
Number of speeds		Inverter controlled
Power input		70 W
Pump additional zone		
Type		DC motor
Number of speeds		Inverter controlled
Power input		70 W
Expansion vessel		
Volume		10 l
Maximum water pressure		3 bar
Prepressure		1 bar
Tank		
Water volume		180 l
Material		Stainless steel (EN1.4521)
Maximum water temperature		65°C
Maximum water pressure		10 bar
Corrosion protection		Anode
Water filter main zone		
Diameter perforations		1 mm
Material		Copper – brass – stainless steel
Water filter additional zone		
Diameter perforations		1 mm
Material		Copper – brass – stainless steel
Water circuit – space heating side (additional zone)		
Piping connections diameter		G 1-1/4" (female)
Safety valve		3 bar
Manometer		Yes
Drain valve/fill valve		Yes ⁽⁴⁾

14 Technical data

Indoor units	EHVZ16S18CB3V
Water circuit – space heating side (main zone)	
Shut-off valve	Yes
Air purge valve	No
Water circuit	
Total water volume	6.4 l ⁽⁶⁾
Refrigerant circuit	
Gas side diameter	15.9 mm
Liquid side diameter	9.5 mm
Sound power level	
Nominal	44 dBA ⁽⁶⁾
Sound pressure level	30 dBA ⁽⁷⁾
Operation range	
Heating (water side)	Maximally 55°C
Indoor installation (ambient)	Minimally 5°C DB
	Maximally 35°C DB
Domestic hot water (water side)	Maximally 60°C ⁽¹⁰⁾
Safety devices	Thermal cut out

Electrical specifications

Indoor units	EHVZ16S18CB3V	
Name	See note 12	
Voltage range	Minimally	-10%
	Maximally	+10%
Voltage range	Minimally	-10%
	Maximally	+10%
Communication cable	Quantity	3
	Remark	2.5 mm ²
Electric meter	Quantity	2
	Remark	Minimum 0.75 mm ² (5 V DC pulse detection)
Preferential kWh rate power supply	Quantity	2
	Remark	Power 6.3 A. See note 13.
Domestic hot water pump	Quantity	2
	Remark	Minimum 0.75 mm ² (2 A inrush, 1 A continuous)
For power supply backup heater	Quantity	3G
	Remark	See note 13
For connection with R6T	Quantity	2
	Remark	Minimum 0.75 mm ²
For connection with A3P	Quantity	Depends on thermostat type, cf. installation manual
	Remark	Voltage: 230 V/max. current: 100 mA/min. 0.75 mm ² . See note 13.
For connection with M2S	Quantity	2
	Remark	Voltage: 230 V/max. current: 100 mA/min. 0.75 mm ² . See note 13.
For connection with bottom plate heater	Quantity	2
	Remark	Voltage: 230 V/min. 0.75 mm ² . See note 13.
For connection with user interface	Quantity	2
	Remark	0.75 mm ² ~1.25 mm ² (max. length 500 m)
For connection with optional FWXV (demand input and output)	Quantity	4
	Remark	100 mA, minimum 0.75 mm ²
For connection with safety thermostat	Quantity	2
	Remark	Minimum 0.75 mm ²

- (1) PED unit category: excluded from scope of PED due to article 1, item 3.6 of 97/23/EC
- (2) Operation area is extended to lower flow rates only in case the unit operates with heat pump only. (Not in startup, no backup heater operation, no defrost operation).
- (4) Drain/Fill valve only available on water inlet connection.
- (5) Including piping + PHE + back-up heater; excluding expansion vessel.
- (6) DB/WB 7°C/6°C – LWC 35°C (DT=5°C)

- (7) The sound pressure level is measured in an anechoic room at 1m distance from the unit. It is a relative value, depending on the distance and acoustic environment.
- (9) Refer to operation range for detail for differences between ERHQ and ERLQ models.
- (10) For ERLQ outdoor units >55°C backup heater only, no heat pump operation.
- (11) For ERHQ outdoor units >50°C backup heater only, no heat pump operation.
- (12) Above mentioned power supply of the hydrobox is for the backup heater only. The switch box and the pump of the hydrobox are supplied via the outdoor unit.
- (13) Select diameter and type according to national and local regulations.

14 Technical data

14.8 Operation range

14.8.1 Operation range: Heating and cooling

Space heating and cooling mode (for current models in this manual)

Remark: Cooling mode is NOT applicable for EHVZ04, EHVZ08, and EHVZ16.

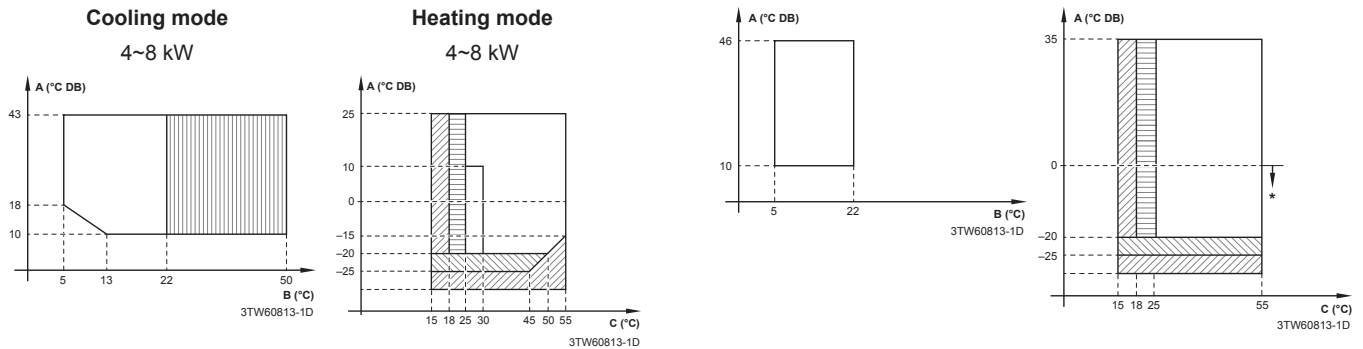

A Outdoor temperature

B Leaving water evaporator temperature

C Leaving water condenser temperature

▨ Backup heater only operation. No outdoor operation.

▩ Outdoor unit operation is possible if setpoint $\geq 25^{\circ}\text{C}$.

▧ Operation of outdoor unit is possible, but with possible capacity reduction. If the outdoor temperature $< -25^{\circ}\text{C}$, the outdoor unit will stop. Indoor unit and backup heater operation will continue.

▩ Pull-down area.

Remark: In restricted power supply mode, the outdoor unit, booster heater, and backup heater can only operate separately.

(*) ERLQ units include special equipment (insulation, heater sheet,...) to ensure proper operation in areas with low ambient temperatures and high humidity conditions. In such conditions, the ERLQ models may experience problems with severe ice buildup on the air-cooled coil. If such conditions are expected, the ERLQ must be installed instead. These models contain countermeasures (insulation, heater sheet,...) to prevent freeze-up.

14.8.2 Operation range: Domestic hot water

Domestic hot water heating mode (for current models in this manual)

Remark: Cooling mode is NOT applicable for EHVZ04, EHVZ08, and EHVZ16.

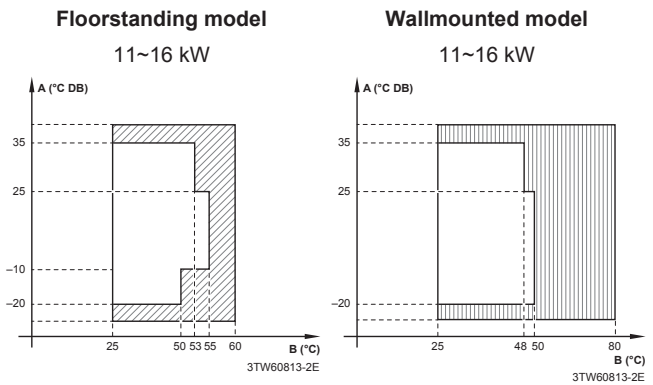
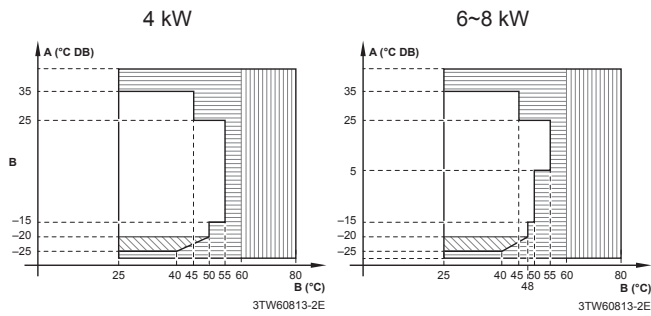

- A** Outdoor temperature
- B** Domestic hot water temperature
- ▨ Backup heater only operation. No outdoor operation.
- ▩ Only booster heater operation EKHW.
- ▧ Operation of outdoor unit is possible, but with possible capacity reduction. If the outdoor temperature <-25°C, the outdoor unit will stop. Indoor unit and backup heater operation will continue.
- ▦ Only booster heater operation EKHW.

Remark: In restricted power supply mode (EKHW only), the outdoor unit, booster heater, and backup heater can only operate separately.

14 Technical data

14.9 ESP curve

14.9.1 ESP curve: Indoor unit

Note: A flow error will occur when the minimum water flow rate is not reached.

EHVZ16S18CB

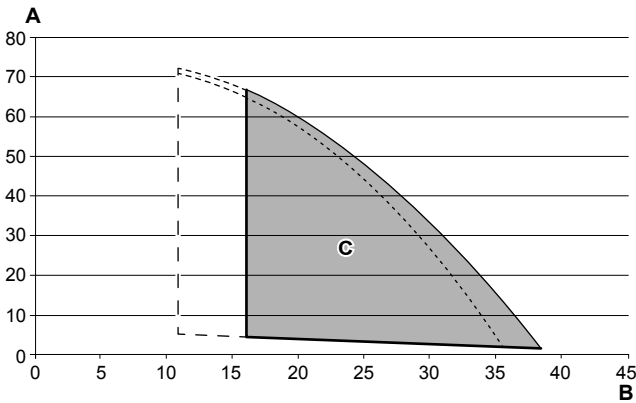

- A** External static pressure (kPa)
- B** Water flow rate (l/min)
- C** Operation range
- Additional/direct zone
- - - - Main/mixed zone

Operation area is extended to lower flow rates only in case the unit operates with heat pump only. (Not in startup, no backup heater operation, no defrost operation).

ESP=External static pressure [kPa] in the space heating circuit.

Flow=Water flow through the unit in the space heating circuit.

Notes:

- Selecting a flow outside the area of operation can cause damage or malfunction of the unit. See also the minimum and maximum allowed water flow range in the technical specifications.
- Water quality **MUST** be according to EN directive EC98/83EC.

15 Glossary

Dealer

Sales distributor for the product.

Authorized installer

Technical skilled person who is qualified to install the product.

User

Person who is owner of the product and/or operates the product.

Applicable legislation

All international, European, national and local directives, laws, regulations and/or codes that are relevant and applicable for a certain product or domain.

Service company

Qualified company which can perform or coordinate the required service to the product.

Installation manual

Instruction manual specified for a certain product or application, explaining how to install, configure and maintain it.

Operation manual

Instruction manual specified for a certain product or application, explaining how to operate it.

Accessories

Labels, manuals, information sheets and equipment that are delivered with the product and that need to be installed according to the instructions in the accompanying documentation.

Optional equipment

Equipment made or approved by Daikin that can be combined with the product according to the instructions in the accompanying documentation.

Field supply

Equipment not made by Daikin that can be combined with the product according to the instructions in the accompanying documentation.

Field settings table

Applicable indoor units

*HVZ04S18CB3V

*HVZ08S18CB3V

*HVZ16S18CB3V

Notes

(*5) *04/08*

(*6) *16*

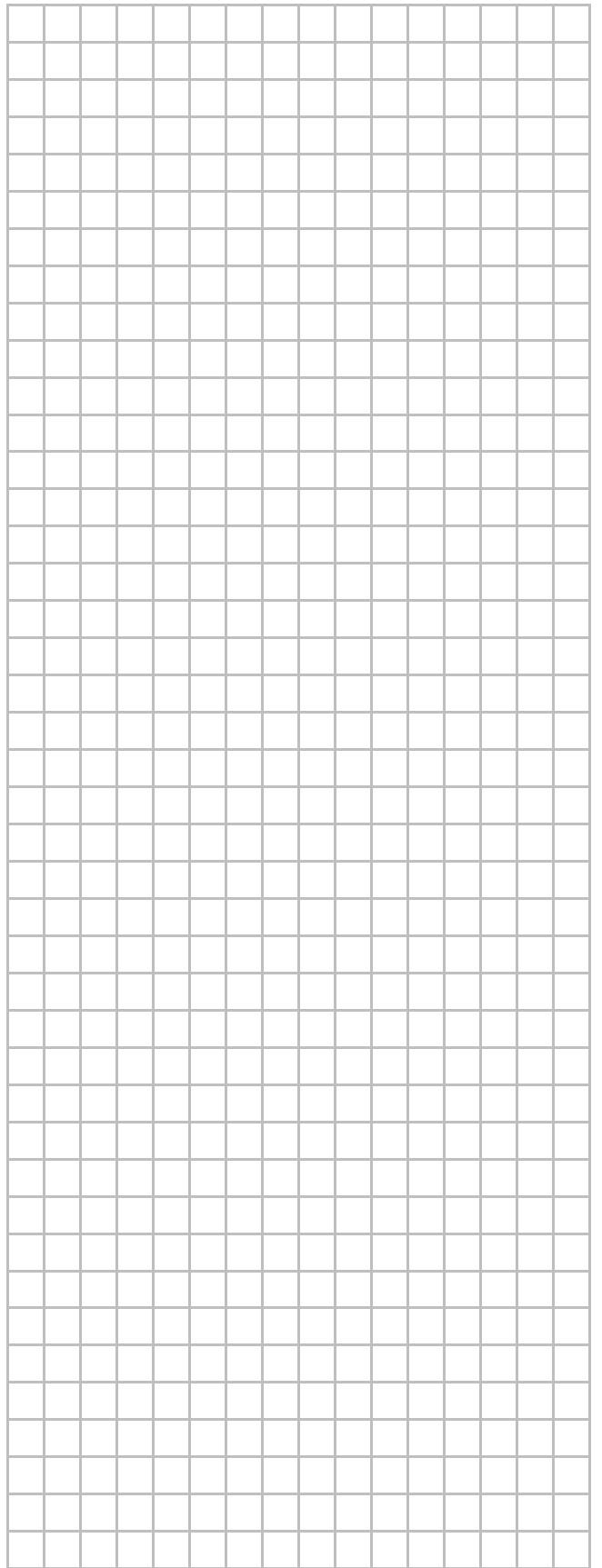
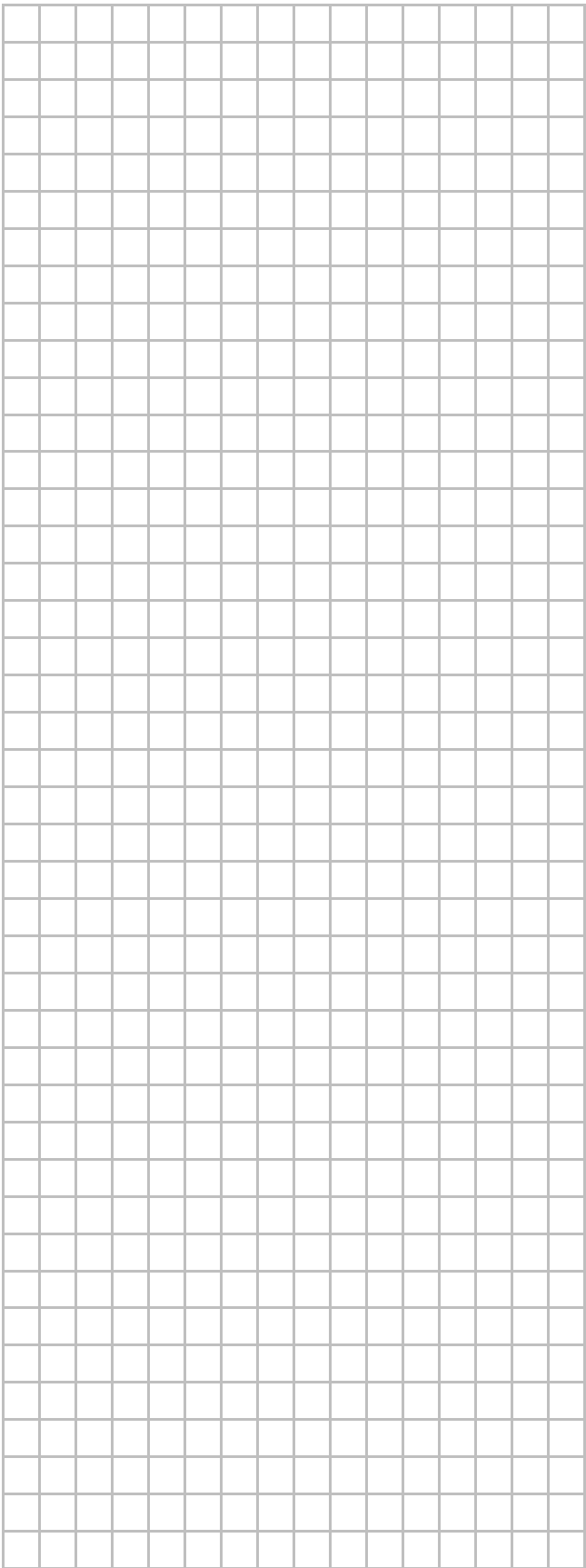

Field settings table					Installer setting at variance with default value	
Breadcrumb	Field code	Setting name	Range, step	Default value	Date	Value
User settings						
└ Preset values						
└ Room temperature						
7.4.1.1		Comfort (heating)	R/W	[3-07]~[3-06], step: A.3.2.4 21°C		
7.4.1.2		Eco (heating)	R/W	[3-07]~[3-06], step: A.3.2.4 19°C		
└ LWT main						
7.4.2.1	[8-09]	Comfort (heating)	R/W	[9-01]~[9-00], step: 1°C 35°C		
7.4.2.2	[8-0A]	Eco (heating)	R/W	[9-01]~[9-00], step: 1°C 33°C		
7.4.2.5		Comfort (heating)	R/W	-10~10°C, step: 1°C 0°C		
7.4.2.6		Eco (heating)	R/W	-10~10°C, step: 1°C -2°C		
└ Tank temperature						
7.4.3.1	[6-0A]	Storage comfort	R/W	30~[6-0E]°C, step: 1°C 60°C		
7.4.3.2	[6-0B]	Storage eco	R/W	30~min(50, [6-0E])°C, step: 1°C 45°C		
7.4.3.3	[6-0C]	Reheat	R/W	30~min(50, [6-0E])°C, step: 1°C 45°C		
└ Quiet level						
7.4.4			R/W	0: Level 1 1: Level 2 2: Level 3		
└ Electricity price						
7.4.5.1	[C-0C] [D-0C]	High	R/W	0,00~990/kWh 0/kWh		
7.4.5.2	[C-0D] [D-0D]	Medium	R/W	0,00~990/kWh 0/kWh		
7.4.5.3	[C-0E] [D-0E]	Low	R/W	0,00~990/kWh 0/kWh		
└ Fuel price						
7.4.6			R/W	0,00~990/kWh 0,00~290/MBtu 8,0/kWh		
└ Set weather dependent						
└ Main						
└ Set weather-dependent heating						
7.7.1.1	[1-00]	Set weather-dependent heating	R/W	Low ambient temp. for LWT main zone heating WD curve. -40~5°C, step: 1°C -10°C		
7.7.1.1	[1-01]	Set weather-dependent heating	R/W	High ambient temp. for LWT main zone heating WD curve. 10~25°C, step: 1°C 15°C		
7.7.1.1	[1-02]	Set weather-dependent heating	R/W	Leaving water value for low ambient temp. for LWT main zone heating WD curve. [9-01]~[9-00]°C, step: 1°C 35°C		
7.7.1.1	[1-03]	Set weather-dependent heating	R/W	Leaving water value for high ambient temp. for LWT main zone heating WD curve. [9-01]~min(45, [9-00])°C, step: 1°C 25°C		
└ Additional						
└ Set weather-dependent heating						
7.7.2.1	[0-00]	Set weather-dependent heating	R/W	Leaving water value for high ambient temp. for LWT add zone heating WD curve. [9-05]~min(45, [9-06])°C, step: 1°C 35°C		
7.7.2.1	[0-01]	Set weather-dependent heating	R/W	Leaving water value for low ambient temp. for LWT add zone heating WD curve. [9-05]~[9-06]°C, step: 1°C 45°C		
7.7.2.1	[0-02]	Set weather-dependent heating	R/W	High ambient temp. for LWT add zone heating WD curve. 10~25°C, step: 1°C 15°C		
7.7.2.1	[0-03]	Set weather-dependent heating	R/W	Low ambient temp. for LWT add zone heating WD curve. -40~5°C, step: 1°C -10°C		
Installer settings						
└ System layout						
└ Standard						
A.2.1.1	[E-00]	Unit type	R/O	0~5 0: LT split		
A.2.1.2	[E-01]	Compressor type	R/O	0: 8 (*5) 1: 16 (*6)		
A.2.1.3	[E-02]	Indoor software type	R/O	1: Type 2		
A.2.1.4	[E-03]	Backup heater steps	R/O	1: 1 step		
A.2.1.5	[5-0D]	BUH type	R/O	1: 1P,(1/1+2)		
A.2.1.6	[D-01]	Preferential kWh rate	R/W	0: No 1: Active open 2: Active closed		
A.2.1.7	[C-07]	Unit control method	R/W	0: LWT control 1: Ext RT control 2: RT control		
A.2.1.8	[7-02]	Number of LWT zones	R/W	0: 1 LWT zone 1: 2 LWT zones		
A.2.1.9	[F-0D]	Pump operation mode	R/W	0: Continuous 1: Sample 2: Request		
A.2.1.A	[E-04]	Power saving possible	R/O	0: No (*6) 1: Yes (*5)		
A.2.1.B		User interface location	R/W	0: At unit 1: In room		
└ Options						
A.2.2.1	[E-05]	DHW operation	R/W	0: No 1: Yes		
A.2.2.3	[E-07]	DHW tank type	R/O	0~6 1: Type 2		
A.2.2.4	[C-05]	Contact type main	R/W	1: Thermo ON/OFF 2: C/H request		
A.2.2.5	[C-06]	Contact type add.	R/W	1: Thermo ON/OFF 2: C/H request		
A.2.2.6.1	[C-02]	Digital I/O PCB	R/W	Ext. backup heat src 0~3 0: No 1: Bivalent		
A.2.2.6.2	[D-07]	Digital I/O PCB	R/O	Solar kit 0~1 0: No		
A.2.2.6.3	[C-09]	Digital I/O PCB	R/W	Alarm output 0: Normally open 1: Normally closed		
A.2.2.6.4	[F-04]	Digital I/O PCB	R/W	Bottom plate heater 0: No 1: Yes		
A.2.2.7	[D-04]	Demand PCB	R/W	0: No 1: Pwr consmp ctrl		

(*5) *04/08*

(*6) *16*

Field settings table					Installer setting at variance with default value		
Breadcrumb	Field code	Setting name		Range, step	Default value	Date	Value
A.2.2.8	[D-08]	External kWh meter 1		R/W	0: No 1: 0,1 pulse/kWh 2: 1 pulse/kWh 3: 10 pulse/kWh 4: 100 pulse/kWh 5: 1000 pulse/kWh		
A.2.2.9	[D-09]	External kWh meter 2		R/W	0: No 1: 0,1 pulse/kWh 2: 1 pulse/kWh 3: 10 pulse/kWh 4: 100 pulse/kWh 5: 1000 pulse/kWh		
A.2.2.A	[D-02]	DHW pump		R/W	0: No 1: Secondary rtm 2: Disinf. shunt		
A.2.2.B	[C-08]	External sensor		R/W	0: No 1: Outdoor sensor 2: Room sensor		
└─ Capacities							
A.2.3.2	[6-03]	BUH: step 1		R/W	0–10 kW, step: 0.2 kW 3 kW		
A.2.3.6	[6-07]	Bottom plate heater		R/W	0–200 W, step: 10 W 0 W		
Space operation							
└─ LWT settings							
└─ Main							
A.3.1.1.1		LWT setpoint mode		R/W	0: Fixed 1: Weather dep. 2: Fixed + scheduled 3: WD + scheduled		
A.3.1.1.2.1	[9-01]	Temperature range	Minimum temp (heating)	R/W	15–37°C, step: 1°C 25°C		
A.3.1.1.2.2	[9-00]	Temperature range	Maximum temp (heating)	R/W	37–55, step: 1°C 55°C		
A.3.1.1.5	[8-05]	Modulated LWT		R/W	0: No 1: Yes		
A.3.1.1.6.1	[F-0B]	Shut-off valve	Thermo On/OFF	R/W	0: No 1: Yes		
A.3.1.1.7	[9-0B]	Emitter type		R/W	0: Quick 1: Slow		
└─ Additional							
A.3.1.2.1		LWT setpoint mode		R/W	0: Fixed 1: Weather dep. 2: Fixed + scheduled 3: WD + scheduled		
A.3.1.2.2.1	[9-05]	Temperature range	Minimum temp (heating)	R/W	15–37°C, step: 1°C 25°C		
A.3.1.2.2.2	[9-06]	Temperature range	Maximum temp (heating)	R/W	37–55, step: 1°C 55°C		
└─ Delta T source							
A.3.1.3.1	[9-09]	Heating		R/W	3–10°C, step: 1°C 5°C		
└─ Room thermostat							
A.3.2.1.1	[3-07]	Room temp. range	Minimum temp (heating)	R/W	12–18°C, step: A.3.2.4 12°C		
A.3.2.1.2	[3-06]	Room temp. range	Maximum temp (heating)	R/W	18–30°C, step: A.3.2.4 30°C		
A.3.2.2	[2-0A]	Room temp. offset		R/W	-5–5°C, step: 0,5°C 0°C		
A.3.2.3	[2-09]	Ext. room sensor offset		R/W	-5–5°C, step: 0,5°C 0°C		
A.3.2.4		Room temp. step		R/W	0; 0,5 °C 1; 1 °C		
└─ Operation range							
A.3.3.1	[4-02]	Space heating OFF temp		R/W	14–35°C, step: 1°C 25°C (*5) 14–35°C, step: 1°C 35°C (*6)		
└─ Domestic hot water (DHW)							
└─ Type							
A.4.1	[6-0D]			R/W	0: Reheat only 1: Reheat + sched. 2: Scheduled only		
└─ Disinfection							
A.4.4.1	[2-01]	Disinfection		R/W	0: No 1: Yes		
A.4.4.2	[2-00]	Operation day		R/W	0: Each day 1: Monday 2: Tuesday 3: Wednesday 4: Thursday 5: Friday 6: Saturday 7: Sunday		
A.4.4.3	[2-02]	Start time		R/W	0–23 hour, step: 1 hour 23		
A.4.4.4	[2-03]	Temperature target		R/W	60°C		
A.4.4.5	[2-04]	Duration		R/W	40–60 min, step: 5 min 40 min		
└─ Maximum setpoint							
A.4.5	[6-0E]			R/W	40–60°C, step: 1°C 60°C		
└─ SP mode							
A.4.6				R/W	0: Fixed 1: Weather dep.		
└─ Weather dependent curve							
A.4.7	[0-0B]	Weather-dependent curve	Leaving water value for high ambient temp. for DHW WD curve.	R/W	35–[6-0E]°C, step: 1°C 55°C		
A.4.7	[0-0C]	Weather-dependent curve	Leaving water value for low ambient temp. for DHW WD curve.	R/W	45–[6-0E]°C, step: 1°C 60°C		
A.4.7	[0-0D]	Weather-dependent curve	High ambient temp. for DHW WD curve.	R/W	10–25°C, step: 1°C 15°C		
A.4.7	[0-0E]	Weather-dependent curve	Low ambient temp. for DHW WD curve.	R/W	-40–5°C, step: 1°C -10°C		
└─ Heat sources							

Field settings table				Installer setting at variance with default value		
Breadcrumb	Field code	Setting name	Range, step	Default value	Date	Value
└ Backup heater						
A.5.1.1	[4-00]	Operation mode	R/W	0: Disabled 1: Enabled 2: Only DHW		
A.5.1.2		Emergency	R/W	0: Manual 1: Automatic		
A.5.1.4	[5-01]	Equilibrium temp.	R/W	-15~35°C, step: 1°C 0°C		
└ System operation						
└ Auto restart						
A.6.1	[3-00]		R/W	0: No 1: Yes		
└ Preferential kWh rate						
A.6.2.1	[D-00]	Allowed heaters	R/W	0~3 0: None 2: BUH only		
A.6.2.2	[D-05]	Forced pump OFF	R/W	0: Forced off 1: As normal		
└ Pwr consumpt. Control						
A.6.3.1	[4-08]	Mode	R/W	0: No limitation 1: Continuous 2: Digital inputs		
A.6.3.2	[4-09]	Type	R/W	0: Current 1: Power		
A.6.3.3	[5-05]	Amp. value	R/W	0~50 A, step: 1 A 50 A		
A.6.3.4	[5-09]	kW value	R/W	0~20 kW, step: 0,5 kW 20 kW		
A.6.3.5.1	[5-05]	Amp. limits for DI	Limit DI1	R/W	0~50 A, step: 1 A 50 A	
A.6.3.5.2	[5-06]	Amp. limits for DI	Limit DI2	R/W	0~50 A, step: 1 A 50 A	
A.6.3.5.3	[5-07]	Amp. limits for DI	Limit DI3	R/W	0~50 A, step: 1 A 50 A	
A.6.3.5.4	[5-08]	Amp. limits for DI	Limit DI4	R/W	0~50 A, step: 1 A 50 A	
A.6.3.6.1	[5-09]	kW limits for DI	Limit DI1	R/W	0~20 kW, step: 0,5 kW 20 kW	
A.6.3.6.2	[5-0A]	kW limits for DI	Limit DI2	R/W	0~20 kW, step: 0,5 kW 20 kW	
A.6.3.6.3	[5-0B]	kW limits for DI	Limit DI3	R/W	0~20 kW, step: 0,5 kW 20 kW	
A.6.3.6.4	[5-0C]	kW limits for DI	Limit DI4	R/W	0~20 kW, step: 0,5 kW 20 kW	
A.6.3.7	[4-01]	Priority	R/W	0~2 0: None 2: BUH		
└ Averaging time						
A.6.4	[1-0A]		R/W	0: No averaging 1: 12 hours 2: 24 hours 3: 48 hours 4: 72 hours		
└ Ext amb. sensor offset						
A.6.5	[2-0B]		R/W	-5~5°C, step: 0,5°C 0°C		
└ Boiler efficiency						
A.6.A	[7-05]		R/W	0: Very high 1: High 2: Medium 3: Low 4: Very low		
└ Overview settings						
A.8	[0-00]	Leaving water value for high ambient temp. for LWT add zone heating WD curve.	R/W	[9-05]-min(45,[9-06])°C, step: 1°C 35°C		
A.8	[0-01]	Leaving water value for low ambient temp. for LWT add zone heating WD curve.	R/W	[9-05]-[9-06]°C, step: 1°C 45°C		
A.8	[0-02]	High ambient temp. for LWT add zone heating WD curve.	R/W	10~25°C, step: 1°C 15°C		
A.8	[0-03]	Low ambient temp. for LWT add zone heating WD curve.	R/W	-40~5°C, step: 1°C -10°C		
A.8	[0-04]	--	R/W	8		
A.8	[0-05]	--	R/W	12		
A.8	[0-06]	--	R/W	35		
A.8	[0-07]	--	R/W	20		
A.8	[0-0B]	Leaving water value for high ambient temp. for DHW WD curve.	R/W	35-[6-0E]°C, step: 1°C 55°C		
A.8	[0-0C]	Leaving water value for low ambient temp. for DHW WD curve.	R/W	45-[6-0E]°C, step: 1°C 60°C		
A.8	[0-0D]	High ambient temp. for DHW WD curve.	R/W	10~25°C, step: 1°C 15°C		
A.8	[0-0E]	Low ambient temp. for DHW WD curve.	R/W	-40~5°C, step: 1°C -10°C		
A.8	[1-00]	Low ambient temp. for LWT main zone heating WD curve.	R/W	-40~5°C, step: 1°C -10°C		
A.8	[1-01]	High ambient temp. for LWT main zone heating WD curve.	R/W	10~25°C, step: 1°C 15°C		
A.8	[1-02]	Leaving water value for low ambient temp. for LWT main zone heating WD curve.	R/W	[9-01]-[9-00], step: 1°C 35°C		
A.8	[1-03]	Leaving water value for high ambient temp. for LWT main zone heating WD curve.	R/W	[9-01]-min(45, [9-00])°C, step: 1°C 25°C		
A.8	[1-04]	--	R/W	1		
A.8	[1-05]	--	R/W	1		
A.8	[1-06]	--	R/W	20		
A.8	[1-07]	--	R/W	35		
A.8	[1-08]	--	R/W	22		
A.8	[1-09]	--	R/W	18		
A.8	[1-0A]	What is the averaging time for the outdoor temp?	R/W	0: No averaging 1: 12 hours 2: 24 hours 3: 48 hours 4: 72 hours		

(*5) *04/08*

(*6) *16*

Field settings table					Installer setting at variance with default value	
Breadcrumb	Field code	Setting name	Range, step	Default value	Date	Value
A.8	[2-00]	When should the disinfection function be executed?	R/W	0: Each day 1: Monday 2: Tuesday 3: Wednesday 4: Thursday 5: Friday 6: Saturday 7: Sunday		
A.8	[2-01]	Should the disinfection function be executed?	R/W	0: No 1: Yes		
A.8	[2-02]	When should the disinfection function start?	R/W	0-23 hour, step: 1 hour 23		
A.8	[2-03]	What is the disinfection target temperature?	R/W	60°C		
A.8	[2-04]	How long must the tank temperature be maintained?	R/W	40-60 min, step: 5 min 40 min		
A.8	[2-05]	Room antifrost temperature	R/W	4-16°C, step: 1°C 12°C		
A.8	[2-06]	Room frost protection	R/W	0: Disabled 1: Enabled		
A.8	[2-09]	Adjust the offset on the measured room temperature	R/W	-5-5°C, step: 0,5°C 0°C		
A.8	[2-0A]	Adjust the offset on the measured room temperature	R/W	-5-5°C, step: 0,5°C 0°C		
A.8	[2-0B]	What is the required offset on the measured outdoor temp.?	R/W	-5-5°C, step: 0,5°C 0°C		
A.8	[3-00]	Is auto restart of the unit allowed?	R/W	0: No 1: Yes		
A.8	[3-01]	--		0		
A.8	[3-02]	--		1		
A.8	[3-03]	--		4		
A.8	[3-04]	--		2		
A.8	[3-05]	--		1		
A.8	[3-06]	What is the maximum desired room temperature in heating?	R/W	18-30°C, step: A.3.2.4 30°C		
A.8	[3-07]	What is the minimum desired room temperature in heating?	R/W	12-18°C, step: A.3.2.4 12°C		
A.8	[3-08]	--	R/W	35°C		
A.8	[3-09]	--	R/W	15°C		
A.8	[4-00]	What is the BUH operation mode?	R/W	0: Disabled 1: Enabled 2: Only DHW		
A.8	[4-01]	Which electric heater has priority?	R/W	0-2 0: None 2: BUH		
A.8	[4-02]	Below which outdoor temperature is heating allowed?	R/W	14-35°C, step: 1°C 25°C (*5) 14-35°C, step: 1°C 35°C (*6)		
A.8	[4-03]	--	R/W	3		
A.8	[4-04]	--		2		
A.8	[4-05]	--		0		
A.8	[4-06]	-- (Do not change this value)		0/1		
A.8	[4-07]	--	R/W	1		
A.8	[4-08]	Which power limitation mode is required on the system?	R/W	0: No limitation 1: Continuous 2: Digital inputs		
A.8	[4-09]	Which power limitation type is required?	R/W	0: Current 1: Power		
A.8	[4-0A]	--		0		
A.8	[4-0B]	--	R/W	1		
A.8	[4-0D]	--	R/W	3		
A.8	[4-0E]	Is the installer on site?	R/W	0: No 1: Yes		
A.8	[5-00]	Is backup heater operation allowed above equilibrium temperature during space heating operation?	R/W	0: Allowed 1: Not allowed		
A.8	[5-01]	What is the equilibrium temperature for the building?	R/W	-15-35°C, step: 1°C 0°C		
A.8	[5-02]	Space heating priority.	R/W	0: Disabled 1: Enabled		
A.8	[5-03]	Space heating priority temperature.	R/W	-15-35°C, step: 1°C 0°C		
A.8	[5-04]	Set point correction for domestic hot water temperature.	R/W	0-20°C, step: 1°C 10°C		
A.8	[5-05]	What is the requested limit for DI1?	R/W	0-50 A, step: 1 A 50 A		
A.8	[5-06]	What is the requested limit for DI2?	R/W	0-50 A, step: 1 A 50 A		
A.8	[5-07]	What is the requested limit for DI3?	R/W	0-50 A, step: 1 A 50 A		
A.8	[5-08]	What is the requested limit for DI4?	R/W	0-50 A, step: 1 A 50 A		
A.8	[5-09]	What is the requested limit for DI1?	R/W	0-20 kW, step: 0,5 kW 20 kW		
A.8	[5-0A]	What is the requested limit for DI2?	R/W	0-20 kW, step: 0,5 kW 20 kW		
A.8	[5-0B]	What is the requested limit for DI3?	R/W	0-20 kW, step: 0,5 kW 20 kW		
A.8	[5-0C]	What is the requested limit for DI4?	R/W	0-20 kW, step: 0,5 kW 20 kW		
A.8	[5-0D]	What type of backup heater installation is used?	R/O	0-5 1: 1P,(1/1+2)		
A.8	[5-0E]	--		1		
A.8	[6-00]	The temperature difference determining the heat pump ON temperature.	R/W	2-20°C, step: 1°C 2°C		
A.8	[6-01]	The temperature difference determining the heat pump OFF temperature.	R/W	0-10°C, step: 1°C 2°C		
A.8	[6-02]	--	R/W	0		
A.8	[6-03]	What is the capacity of the backup heater step 1?	R/W	0-10 kW, step: 0,2 kW 3 kW		
A.8	[6-04]	--	R/W	0		
A.8	[6-05]	--		0		
A.8	[6-06]	--		0		
A.8	[6-07]	What is the capacity of the bottom plate heater?	R/W	0-200 W, step: 10 W 0 W		

Field settings table					Installer setting at variance with default value	
Breadcrumb	Field code	Setting name	Range, step	Default value	Date	Value
A.8	[6-08]	What is the hysteresis to be used in reheat mode?	R/W	2-20°C, step: 1°C 10°C		
A.8	[6-09]	--		0		
A.8	[6-0A]	What is the desired comfort storage temperature?	R/W	30-[6-0E]°C, step: 1°C 60°C		
A.8	[6-0B]	What is the desired eco storage temperature?	R/W	30-min(50, [6-0E])°C, step: 1°C 45°C		
A.8	[6-0C]	What is the desired reheat temperature?	R/W	30-min(50, [6-0E])°C, step: 1°C 45°C		
A.8	[6-0D]	What is the desired DHW production type?	R/W	0: Reheat only 1: Reheat + sched. 2: Scheduled only		
A.8	[6-0E]	What is the maximum temperature setpoint?	R/W	40-60°C, step: 1°C 60°C		
A.8	[7-00]	--	R/W	0		
A.8	[7-01]	--	R/W	2		
A.8	[7-02]	How many leaving water temperature zones are there?	R/W	0: 1 LWT zone 1: 2 LWT zones		
A.8	[7-03]	--		2,5		
A.8	[7-04]	--		0		
A.8	[7-05]	Boiler efficiency	R/W	0: Very high 1: High 2: Medium 3: Low 4: Very low 1 min		
A.8	[8-00]	--		1 min		
A.8	[8-01]	Maximum running time for domestic hot water operation.	R/W	5-95 min, step: 5 min 30 min		
A.8	[8-02]	Anti-recycling time.	R/W	0-10 hour, step: 0,5 hour 0,5 hour		
A.8	[8-03]	--	R/W	50		
A.8	[8-04]	Additional running time for the maximum running time.	R/W	0-95 min, step: 5 min 95 min		
A.8	[8-05]	Allow modulation of the LWT to control the room temp?	R/W	0: No 1: Yes		
A.8	[8-06]	Leaving water temperature maximum modulation.	R/W	0-10°C, step: 1°C 3°C		
A.8	[8-07]	--	R/W	18		
A.8	[8-08]	--	R/W	20		
A.8	[8-09]	What is the desired comfort main LWT in heating?	R/W	[9-01]-[9-00], step: 1°C 35°C		
A.8	[8-0A]	What is the desired eco main LWT in heating?	R/W	[9-01]-[9-00], step: 1°C 33°C		
A.8	[8-0B]	--		13		
A.8	[8-0C]	--		10		
A.8	[8-0D]	--		16		
A.8	[9-00]	What is the maximum desired LWT for main zone in heating?	R/W	37-55, step: 1°C 55°C		
A.8	[9-01]	What is the minimum desired LWT for main zone in heating?	R/W	15-37°C, step: 1°C 25°C		
A.8	[9-02]	--	R/W	22		
A.8	[9-03]	--	R/W	5		
A.8	[9-04]	Leaving water temperature overshoot temperature.	R/W	1-4°C, step: 1°C 1°C		
A.8	[9-05]	What is the minimum desired LWT for add. zone in heating?	R/W	15-37°C, step: 1°C 25°C		
A.8	[9-06]	What is the maximum desired LWT for add. zone in heating?	R/W	37-55, step: 1°C 55°C		
A.8	[9-07]	--	R/W	5		
A.8	[9-08]	--	R/W	22		
A.8	[9-09]	What is the desired delta T in heating?	R/W	3-10°C, step: 1°C 5°C		
A.8	[9-0A]	--	R/W	5		
A.8	[9-0B]	What emitter type is connected to the main LWT zone?	R/W	0: Quick 1: Slow		
A.8	[9-0C]	Room temperature hysteresis.	R/W	1-6°C, step: 0,5°C 1°C		
A.8	[9-0D]	Pump speed limitation	R/W	0-8, step:1 0 : 100% 1-4 : 80-50% 5-8 : 80-50% 6		
A.8	[9-0E]	--		6		
A.8	[A-00]	--		0		
A.8	[A-01]	--		0 (*5) 3 (*6)		
A.8	[A-02]	--		0 (*5) 1 (*6)		
A.8	[A-03]	--		0		
A.8	[A-04]	--		0		
A.8	[B-00]	--		0		
A.8	[B-01]	--		0		
A.8	[B-02]	--		0		
A.8	[B-03]	--		0		
A.8	[B-04]	--		0		
A.8	[C-00]	Domestic heating water priority.	R/O	0-1 1: Heat pump priority		
A.8	[C-01]	--		0		
A.8	[C-02]	Is an external backup heat source connected?	R/W	0-3 0: No 1: Bivalent		
A.8	[C-03]	Bivalent activation temperature.	R/W	-25-25°C, step: 1°C 0°C		
A.8	[C-04]	Bivalent hysteresis temperature.	R/W	2-10°C, step: 1°C 3°C		
A.8	[C-05]	What is the thermo request contact type for the main zone?	R/W	1: Thermo ON/OFF 2: C/H request		
A.8	[C-06]	What is the thermo request contact type for the add. zone?	R/W	0: - 1: Thermo ON/OFF 2: C/H request		
A.8	[C-07]	What is the unit control method in space operation?	R/W	0: LWT control 1: Ext RT control 2: RT control		

(*5) *04/08*

(*6) *16*

Field settings table					Installer setting at variance with default value	
Breadcrumb	Field code	Setting name	Range, step	Default value	Date	Value
A.8	[C-08]	Which type of external sensor is installed?	R/W	0: No 1: Outdoor sensor 2: Room sensor		
A.8	[C-09]	What is the required alarm output contact type?	R/W	0: Normally open 1: Normally closed		
A.8	[C-0A]	--		0		
A.8	[C-0C]	High electricity price decimal (Do not use)	R/W	0-7 0		
A.8	[C-0D]	Medium electricity price decimal (Do not use)	R/W	0-7 0		
A.8	[C-0E]	Low electricity price decimal (Do not use)	R/W	0-7 0		
A.8	[D-00]	Which heaters are permitted if prefer. kWh rate PS is cut?	R/W	0-3 0: None 2: BUH only		
A.8	[D-01]	Contact type of preferential kWh rate PS installation?	R/W	0: No 1: Active open 2: Active closed		
A.8	[D-02]	Which type of DHW pump is installed?	R/W	0: No 1: Secondary rtrn 2: Disinf. shunt		
A.8	[D-03]	Leaving water temperature compensation around 0°C.	R/W	0: Disabled 1: Enabled, shift 2°C (from -2 to 2°C) 2: Enabled, shift 4°C (from -2 to 2°C) 3: Enabled, shift 2°C (from -4 to 4°C) 4: Enabled, shift 4°C (from -4 to 4°C)		
A.8	[D-04]	Is a demand PCB connected?	R/W	0: No 1: Pwr consmp ctrl		
A.8	[D-05]	Is the pump allowed to run if prefer. kWh rate PS is cut?	R/W	0: Forced off 1: As normal		
A.8	[D-07]	--	R/O	0		
A.8	[D-08]	Is an external kWh meter used for power measurement?	R/W	0: No 1: 0,1 pulse/kWh 2: 1 pulse/kWh 3: 10 pulse/kWh 4: 100 pulse/kWh 5: 1000 pulse/kWh		
A.8	[D-09]	Is an external kWh meter used for power measurement?	R/W	0: No 1: 0,1 pulse/kWh 2: 1 pulse/kWh 3: 10 pulse/kWh 4: 100 pulse/kWh 5: 1000 pulse/kWh		
A.8	[D-0A]	--		0		
A.8	[D-0B]	--		2		
A.8	[D-0C]	What is the high electricity price (Do not use)	R/W	0-49 0		
A.8	[D-0D]	What is the medium electricity price (Do not use)	R/W	0-49 0		
A.8	[D-0E]	What is the low electricity price (Do not use)	R/W	0-49 0		
A.8	[E-00]	Which type of unit is installed?	R/O	0-5 0: LT split		
A.8	[E-01]	Which type of compressor is installed?	R/O	0: 8 (*5) 1: 16 (*6)		
A.8	[E-02]	What is the indoor unit software type?	R/O	0-1 1: Type 2		
A.8	[E-03]	What is the number of backup heater steps?	R/O	0-2 1: 1 step		
A.8	[E-04]	Is the power saving function available on the outdoor unit?	R/O	0: No (*6) 1: Yes (*5)		
A.8	[E-05]	Can the system prepare domestic hot water?	R/W	0: No 1: Yes		
A.8	[E-06]	Is a DHW tank installed in the system?	R/O	0: No 1: Yes		
A.8	[E-07]	What kind of DHW tank is installed?	R/O	0-6 1: Type 2		
A.8	[E-08]	Power saving function for outdoor unit.	R/W	0: Disabled (*6) 1: Enabled (*5)		
A.8	[E-09]	--		0		
A.8	[E-0A]	--		0		
A.8	[E-0B]	Is a bi-zone kit installed?	R/O	0-1 1: Yes		
A.8	[E-0C]	--		0		
A.8	[E-0D]	--		0		
A.8	[F-00]	Pump operation allowed outside range.	R/W	0: Disabled 1: Enabled		
A.8	[F-01]	--	R/W	20		
A.8	[F-02]	Bottom plate heater ON temperature.	R/W	3-10°C, step: 1°C 3°C		
A.8	[F-03]	Bottom plate heater hysteresis.	R/W	2-5°C, step: 1°C 5°C		
A.8	[F-04]	Is a bottom plate heater connected?	R/W	0: No 1: Yes		
A.8	[F-05]	--		0		
A.8	[F-06]	--		0		
A.8	[F-09]	Pump operation during flow abnormality.	R/W	0: Disabled 1: Enabled		
A.8	[F-0A]	--		0		
A.8	[F-0B]	Close shut-off valve during thermo OFF?	R/W	0: No 1: Yes		
A.8	[F-0C]	--	R/W	1		
A.8	[F-0D]	What is the pump operation mode?	R/W	0: Continuous 1: Sample 2: Request		

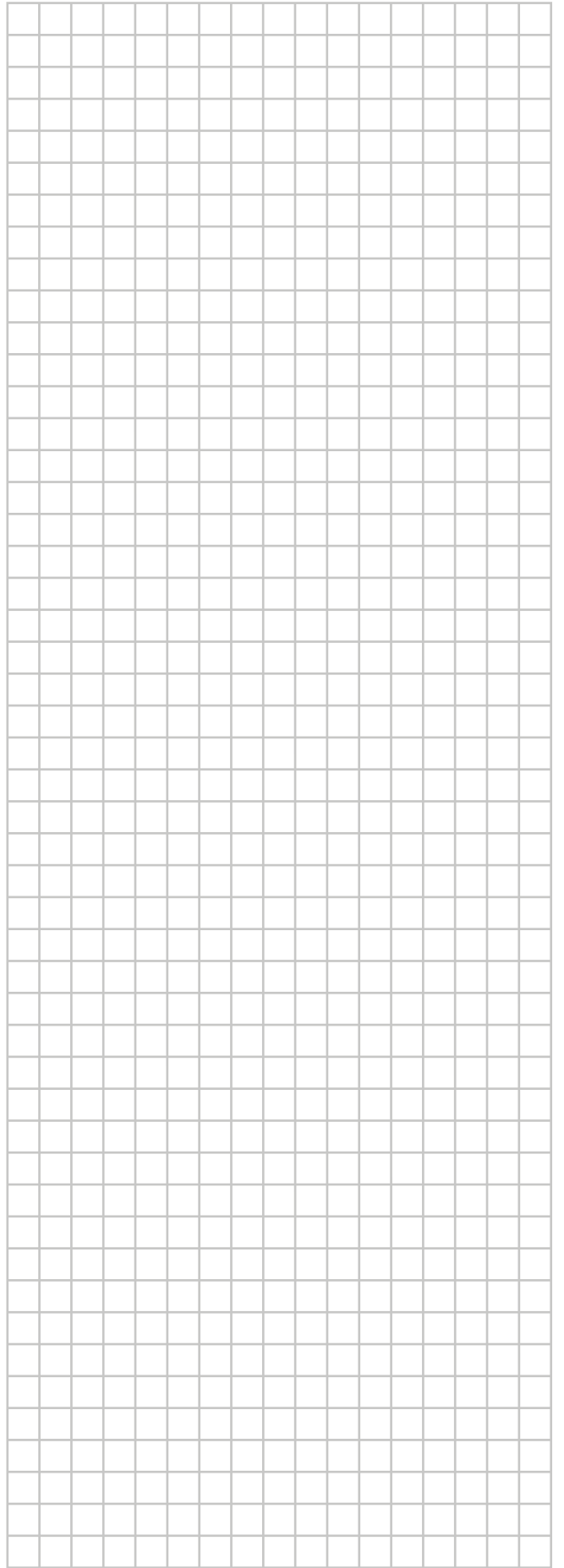
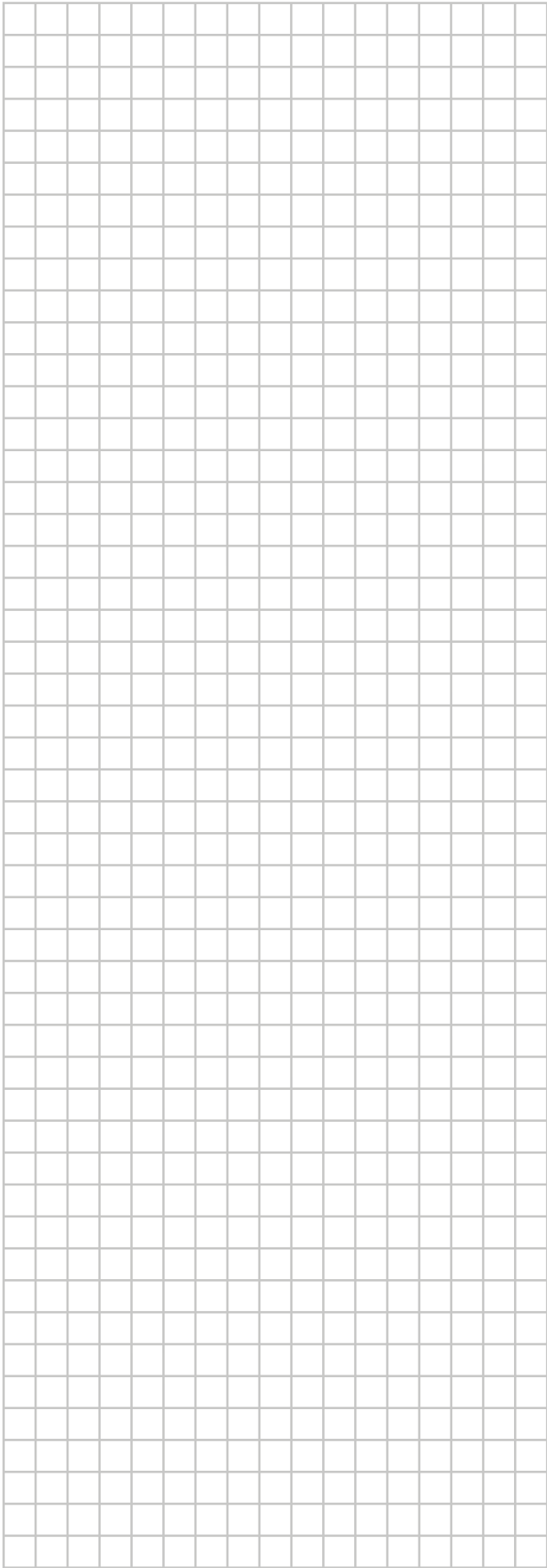

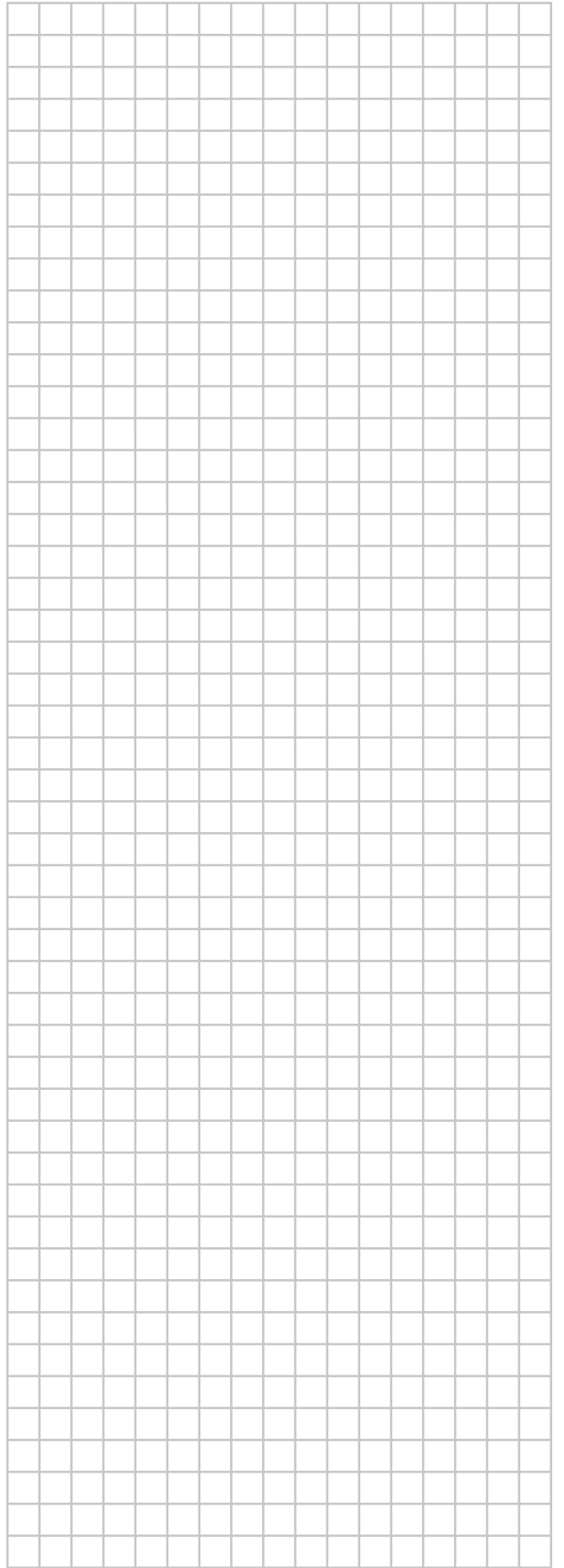
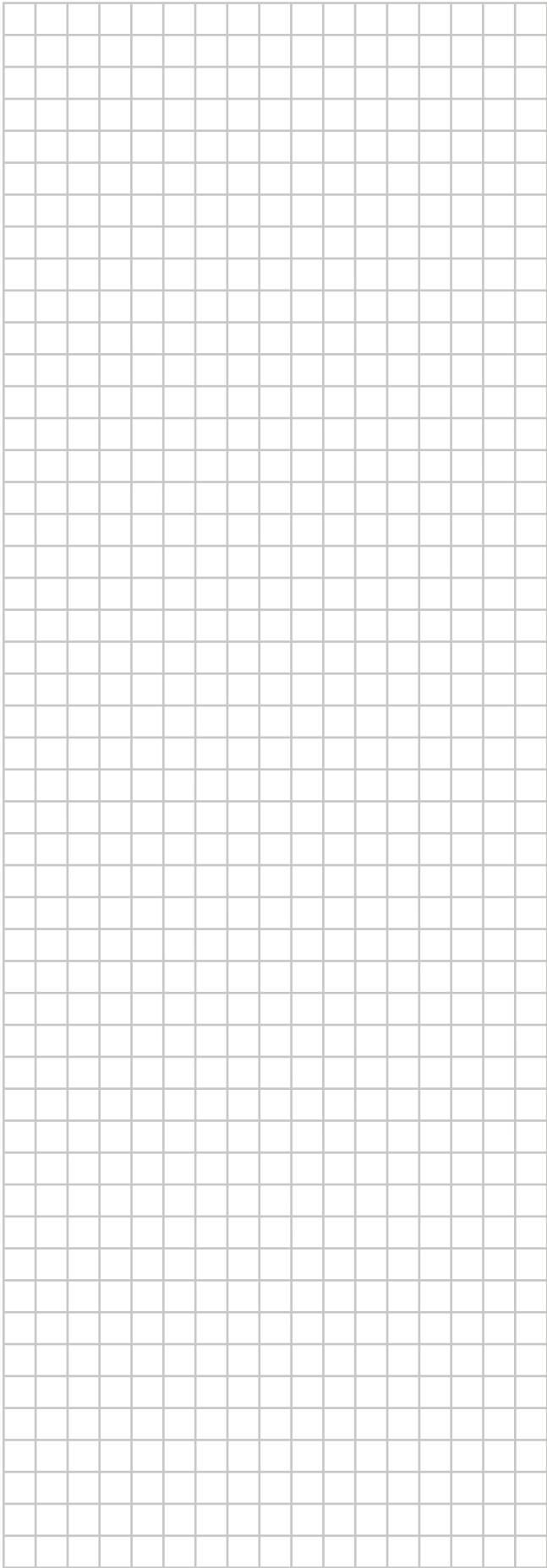

ERC

Copyright 2015 Daikin

DAIKIN EUROPE N.V.
Zandvoordestraat 300, B-8400 Oostende, Belgium

4P401677-1 2015.02