

Installation manual

Daikin Altherma 3 R F

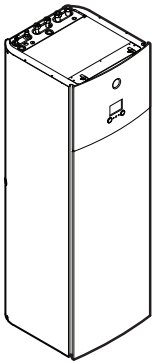

EHVH04S18D*6V(G)
EHVH04S23D*6V(G)

EHVH08S18D*6V(G)
EHVH08S23D*6V(G)
EHVH08S18D*9W(G)
EHVH08S23D*9W(G)

EHVX04S18D*3V(G)
EHVX04S18D*6V(G)
EHVX04S23D*3V(G)
EHVX04S23D*6V(G)

EHVX08S18D*6V(G)
EHVX08S23D*6V(G)
EHVX08S18D*9W(G)
EHVX08S23D*9W(G)

1 Table of contents

Table of contents

| | | |
|----------|--|-----------|
| 1 | About the documentation | 4 |
| 1.1 | About this document..... | 4 |
| 2 | About the box | 5 |
| 2.1 | Indoor unit | 5 |
| 2.1.1 | To remove the accessories from the indoor unit..... | 5 |
| 2.1.2 | To handle the indoor unit | 5 |
| 3 | Preparation | 5 |
| 3.1 | Preparing the installation site | 5 |
| 3.1.1 | Installation site requirements of the indoor unit | 5 |
| 3.2 | Preparing water piping | 7 |
| 3.2.1 | To check the water volume and flow rate | 7 |
| 3.3 | Preparing electrical wiring | 7 |
| 3.3.1 | Overview of electrical connections for external and internal actuators | 7 |
| 4 | Installation | 7 |
| 4.1 | Opening the units | 7 |
| 4.1.1 | To open the indoor unit | 7 |
| 4.1.2 | To open the switch box cover of the indoor unit | 8 |
| 4.1.3 | To lower the switch box on the indoor unit..... | 8 |
| 4.2 | Mounting the indoor unit..... | 9 |
| 4.2.1 | To install the indoor unit..... | 9 |
| 4.2.2 | To connect the drain hose to the drain | 9 |
| 4.3 | Connecting the refrigerant piping | 9 |
| 4.3.1 | To connect the refrigerant piping to the indoor unit | 9 |
| 4.4 | Connecting the water piping..... | 10 |
| 4.4.1 | To connect the water piping..... | 10 |
| 4.4.2 | To connect the recirculation piping | 10 |
| 4.4.3 | To fill the water circuit | 10 |
| 4.4.4 | To fill the domestic hot water tank | 10 |
| 4.4.5 | To insulate the water piping | 10 |
| 4.5 | Connecting the electrical wiring..... | 10 |
| 4.5.1 | About electrical compliance | 11 |
| 4.5.2 | To connect the electrical wiring on the indoor unit..... | 11 |
| 4.5.3 | To connect the main power supply | 11 |
| 4.5.4 | To connect the backup heater power supply | 12 |
| 4.5.5 | To connect the shut-off valve | 13 |
| 4.5.6 | To connect the electricity meters | 13 |
| 4.5.7 | To connect the domestic hot water pump | 14 |
| 4.5.8 | To connect the alarm output | 14 |
| 4.5.9 | To connect the space cooling/heating ON/OFF output..... | 14 |
| 4.5.10 | To connect the changeover to external heat source.... | 14 |
| 4.5.11 | To connect the power consumption digital inputs | 14 |
| 4.5.12 | To connect the safety thermostat (normally closed contact) | 15 |
| 4.6 | Finishing the indoor unit installation | 15 |
| 4.6.1 | To close the indoor unit..... | 15 |
| 5 | Configuration | 15 |
| 5.1 | Overview: Configuration | 15 |
| 5.1.1 | To access the most used commands | 16 |
| 5.2 | Configuration wizard..... | 16 |
| 5.2.1 | Configuration wizard: Language | 16 |
| 5.2.2 | Configuration wizard: Time and date | 16 |
| 5.2.3 | Configuration wizard: System | 17 |
| 5.2.4 | Configuration wizard: Backup heater | 18 |
| 5.2.5 | Configuration wizard: Main zone..... | 18 |
| 5.2.6 | Configuration wizard: Additional zone..... | 19 |
| 5.2.7 | Detailed screen with weather-dependent curve..... | 19 |
| 5.2.8 | Configuration wizard: Tank | 20 |
| 5.3 | Settings menu | 20 |
| 5.3.1 | Main zone | 20 |
| 5.3.2 | Additional zone | 20 |

| | | |
|----------|---|-----------|
| 5.3.3 | Information | 20 |
| 5.4 | Menu structure: Overview installer settings..... | 21 |
| 6 | Commissioning | 22 |
| 6.1 | Checklist before commissioning | 22 |
| 6.2 | Checklist during commissioning | 22 |
| 6.2.1 | To check the minimum flow rate | 22 |
| 6.2.2 | To perform an air purge | 22 |
| 6.2.3 | To perform an operation test run | 23 |
| 6.2.4 | To perform an actuator test run | 23 |
| 6.2.5 | To perform an underfloor heating screed dryout..... | 23 |
| 7 | Hand-over to the user | 23 |
| 8 | Technical data | 25 |
| 8.1 | Piping diagram: Indoor unit | 25 |
| 8.2 | Wiring diagram: Indoor unit | 26 |
| 8.3 | Table 1 – Maximum refrigerant charge allowed in a room: indoor unit..... | 29 |
| 8.4 | Table 2 – Minimum floor area: indoor unit..... | 29 |
| 8.5 | Table 3 – Minimum venting opening area for natural ventilation: indoor unit | 29 |

1 About the documentation

1.1 About this document

Target audience

Authorised installers

Documentation set

This document is part of a documentation set. The complete set consists of:

- **General safety precautions:**
 - Safety instructions that you must read before installing
 - Format: Paper (in the box of the indoor unit)
- **Indoor unit installation manual:**
 - Installation instructions
 - Format: Paper (in the box of the indoor unit)
- **Outdoor unit installation manual:**
 - Installation instructions
 - Format: Paper (in the box of the outdoor unit)
- **Installer reference guide:**
 - Preparation of the installation, good practices, reference data,...
 - Format: Digital files on <http://www.daikineurope.com/support-and-manuals/product-information/>
- **Addendum book for optional equipment:**
 - Additional info about how to install optional equipment
 - Format: Paper (in the box of the indoor unit) + Digital files on <http://www.daikineurope.com/support-and-manuals/product-information/>

Latest revisions of the supplied documentation may be available on the regional Daikin website or via your dealer.

The original documentation is written in English. All other languages are translations.

Technical engineering data

- A **subset** of the latest technical data is available on the regional Daikin website (publicly accessible).
- The **full set** of latest technical data is available on the Daikin extranet (authentication required).

2 About the box

2.1 Indoor unit

2.1.1 To remove the accessories from the indoor unit

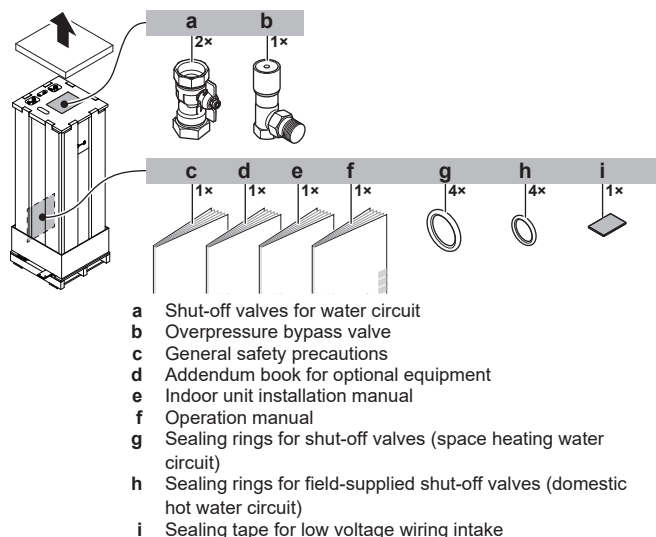

2.1.2 To handle the indoor unit

Use the handles at the back and at the bottom to carry the unit.

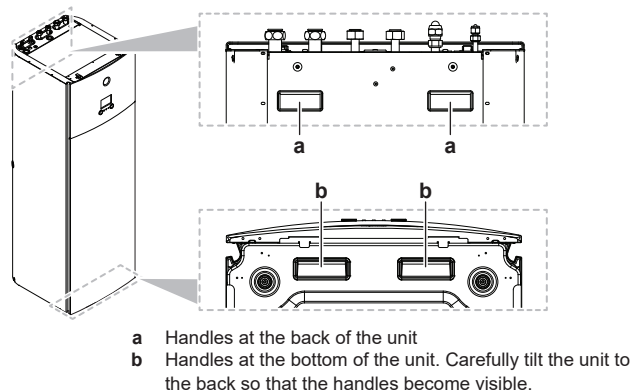

3 Preparation

3.1 Preparing the installation site



WARNING

The appliance shall be stored in a room without continuously operating ignition sources (example: open flames, an operating gas appliance or an operating electric heater).



WARNING

DO NOT reuse refrigerant piping that has been used with any other refrigerant. Replace the refrigerant pipes or clean thoroughly.

3.1.1 Installation site requirements of the indoor unit

- The indoor unit is designed for indoor installation only and for the following ambient temperatures:
 - Space heating operation: 5~30°C
 - Space cooling operation: 5~35°C
 - Domestic hot water production: 5~35°C
- Mind the following spacing installation guidelines:

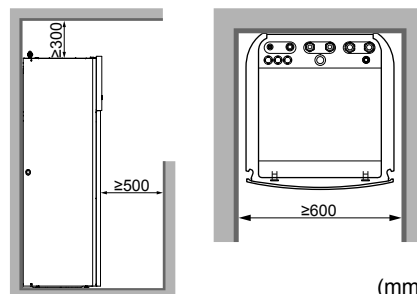

INFORMATION

If you have limited installation space, do the following before installing the unit in its final position: ["4.2.2 To connect the drain hose to the drain"](#) on page 9. It requires to remove one or both side panels.

Special requirements for R32



WARNING

- Do NOT pierce or burn.
- Do NOT use means to accelerate the defrosting process or to clean the equipment, other than those recommended by the manufacturer.
- Be aware that R32 refrigerant does NOT contain an odour.



WARNING

The appliance shall be stored so as to prevent mechanical damage and in a well-ventilated room without continuously operating ignition sources (example: open flames, an operating gas appliance or an operating electric heater) and have a room size as specified below.



NOTICE

- Do NOT re-use joints which have been used already.
- Joints made in installation between parts of refrigerant system shall be accessible for maintenance purposes.



WARNING

Make sure installation, servicing, maintenance and repair comply with instructions from Daikin and with applicable legislation (for example national gas regulation) and are executed only by authorised persons.



NOTICE

- Pipework shall be protected from physical damage.
- Installation of pipework shall be kept to a minimum.

3 Preparation

If the total refrigerant charge in the system is ≥ 1.84 kg (i.e. if the piping length is ≥ 27 m), you need to comply with the minimum floor area requirements as described in the following flow chart. The flow chart uses the following tables: "8.3 Table 1 – Maximum refrigerant charge allowed in a room: indoor unit" on page 29, "8.4 Table 2 – Minimum floor area: indoor unit" on page 29 and "8.5 Table 3 – Minimum venting opening area for natural ventilation: indoor unit" on page 29.

i INFORMATION

Systems with a total refrigerant charge (m_c) < 1.84 kg (i.e. if the piping length is < 27 m) are NOT subjected to any requirements to the installation room.

i INFORMATION

Multiple indoor units. If two or more indoor units are installed in a room, you must consider the maximum refrigerant charge that can be released in the room when a SINGLE leak occurs. **Example:** If two indoor units are installed in the room, each with its own outdoor unit, then you have to consider the refrigerant charge of the largest indoor-outdoor combination.

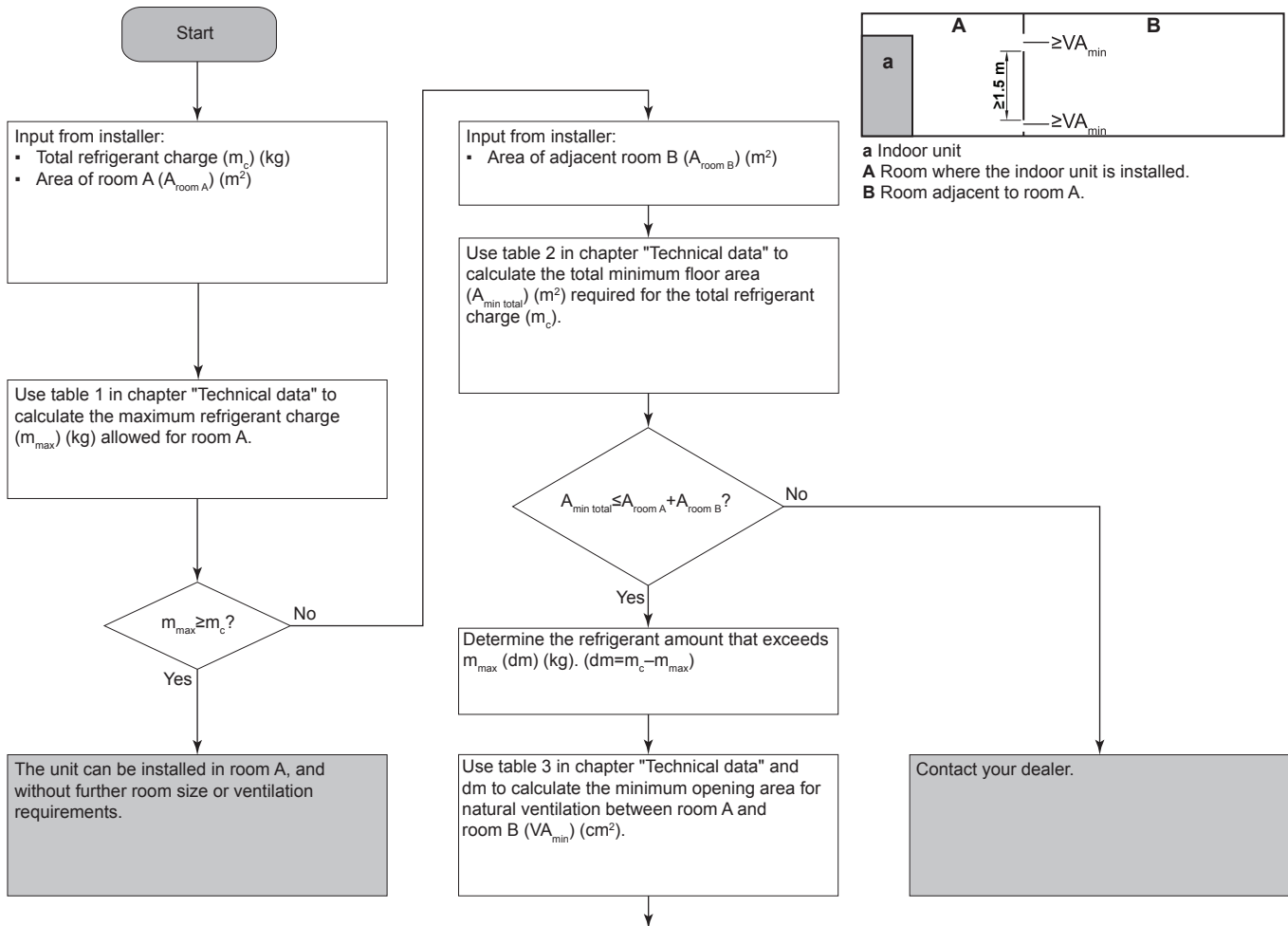

Unit can be installed at **room A** if:

- 2 ventilation openings (permanently open) are provided between room A and B, 1 at the top and 1 at the bottom.
- **Bottom opening:** The bottom opening must meet the minimum area requirements (VA_{min}). It must be as close as possible to the floor. If the ventilation opening starts from the floor, the height must be ≥ 20 mm. The bottom of the opening must be situated ≤ 100 mm from the floor. At least 50% of the required opening area must be situated < 200 mm from the floor. The entire area of the opening must be situated < 300 mm from the floor.
- **Top opening:** The area of the top opening must be larger than or equal to the bottom opening. The bottom of the top opening must be situated at least 1.5 m above the top of the bottom opening.
- Ventilation openings to the outside are NOT considered suitable ventilation openings (the user can block them when it is cold).

3.2 Preparing water piping



NOTICE

In case of plastic pipes, make sure they are fully oxygen diffusion tight according to DIN 4726. The diffusion of oxygen into the piping can lead to excessive corrosion.

- **Valve towards expansion vessel.** The valve towards the expansion vessel (if equipped) **MUST** be open.

3.2.1 To check the water volume and flow rate

Minimum water volume

There are no requirements for the minimum water volume.

Minimum flow rate

Check that the minimum flow rate in the installation is guaranteed in all conditions. This minimum flow rate is required during defrost/ backup heater operation. For this purpose, use the overpressure bypass valve delivered with the unit.



NOTICE

When circulation in each or certain space heating loops is controlled by remotely controlled valves, it is important that the minimum flow rate is guaranteed, even if all valves are closed. In case the minimum flow rate cannot be reached, a flow error 7H will be generated (no heating or operation).

See the installer reference guide for more information.

| Minimum required flow rate |
|----------------------------|
| 12 l/min |

See the recommended procedure as described in "6.2 Checklist during commissioning" on page 22.

3.3 Preparing electrical wiring

3.3.1 Overview of electrical connections for external and internal actuators

| Item | Description | Wires | Maximum running current |
|--|---|------------------|-------------------------|
| Outdoor unit and indoor unit power supply | | | |
| 1 | Power supply for outdoor unit | 2+GND | (a) |
| 2 | Power supply and interconnection cable to indoor unit | 3 | (f) |
| 3 | Power supply for backup heater | See table below. | — |
| 4 | Preferential kWh rate power supply (voltage free contact) | 2 | (d) |
| 5 | Normal kWh rate power supply | 2 | 6.3 A |
| Optional equipment | | | |
| 6 | User interface used as room thermostat | 2 | (e) |
| 7 | Room thermostat | 3 or 4 | 100 mA ^(b) |
| 8 | Outdoor ambient temperature sensor | 2 | (b) |
| 9 | Indoor ambient temperature sensor | 2 | (b) |
| 10 | Heat pump convector | 2 | 100 mA ^(b) |
| Field supplied components | | | |

| Item | Description | Wires | Maximum running current |
|------|--|----------------------|-------------------------|
| 11 | Shut-off valve | 2 | 100 mA ^(b) |
| 12 | Electricity meter | 2 (per meter) | (b) |
| 13 | Domestic hot water pump | 2 | (b) |
| 14 | Alarm output | 2 | (b) |
| 15 | Changeover to external heat source control | 2 | (b) |
| 16 | Space cool/heat operation control | 2 | (b) |
| 17 | Power consumption digital inputs | 2 (per input signal) | (b) |
| 18 | Safety thermostat | 2 | (d) |

- (a) Refer to name plate on outdoor unit.
- (b) Minimum cable section 0.75 mm².
- (c) Cable section 2.5 mm².
- (d) Cable section 0.75 mm² till 1.25 mm²; maximum length: 50 m. Voltage-free contact shall ensure the minimum applicable load of 15 V DC, 10 mA.
- (e) Cable section 0.75 mm² till 1.25 mm²; maximum length: 500 m.
- (f) Cable section 1.5 mm².



NOTICE

More technical specifications of the different connections are indicated on the inside of the indoor unit.

| Backup heater type | Power supply | Required number of conductors |
|--------------------|----------------|-------------------------------|
| *3V | 1N~ 230 V | 2+GND |
| *6V | 1N~ 230 V (6V) | 2+GND |
| | 3~ 230 V (6T1) | 3+GND |
| *9W | 3N~ 400 V | 4+GND |

4 Installation

4.1 Opening the units

4.1.1 To open the indoor unit

- 1 Remove the top panel.

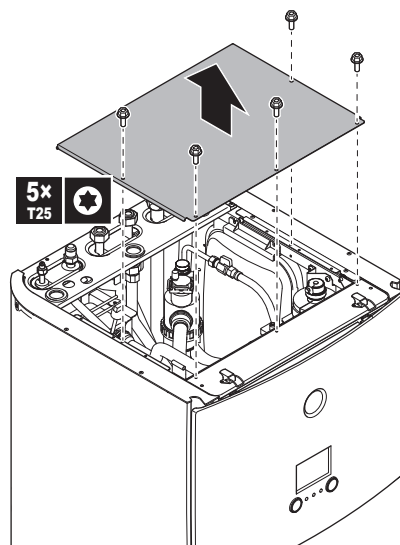

- 2 Remove the user interface panel. Open the hinges at the top and slide the top panel upwards.

4 Installation

NOTICE

If you remove the user interface panel, also disconnect the cables from the back of the user interface panel to prevent damage.

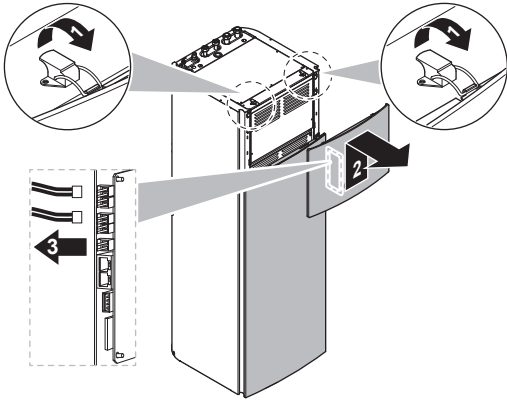

3 If necessary, remove the front plate. This is, for example, necessary in the following cases:

- "4.1.3 To lower the switch box on the indoor unit" on page 8
- "4.2.2 To connect the drain hose to the drain" on page 9
- When you need access to the high voltage switch box

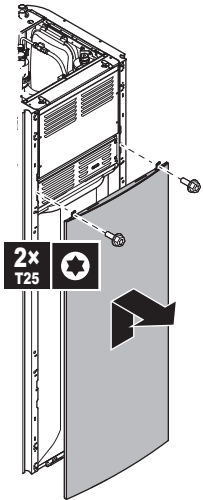

4.1.2 To open the switch box cover of the indoor unit

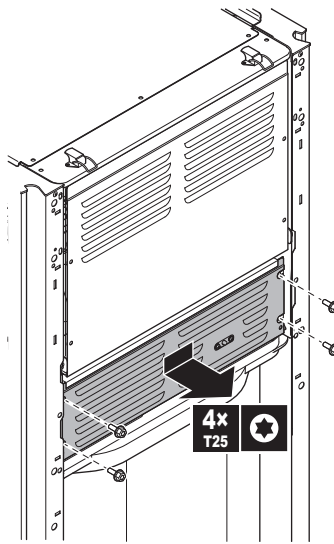
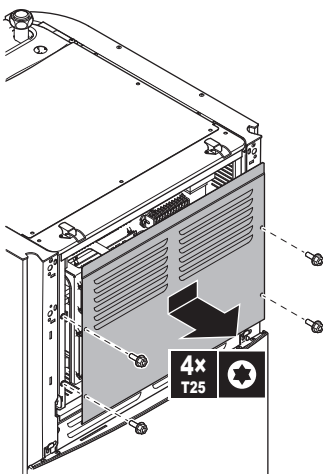

4.1.3 To lower the switch box on the indoor unit

During the installation, you will need access to the inside of the indoor unit. To have easier front access, put the switch box lower on the unit as follows:

Prerequisite: The user interface panel and front panel have been removed.

- 1 Remove the top panel that keeps the switch box into place at the top of the unit.
- 2 Tilt the switch box to the front and lift it out of its hinges.

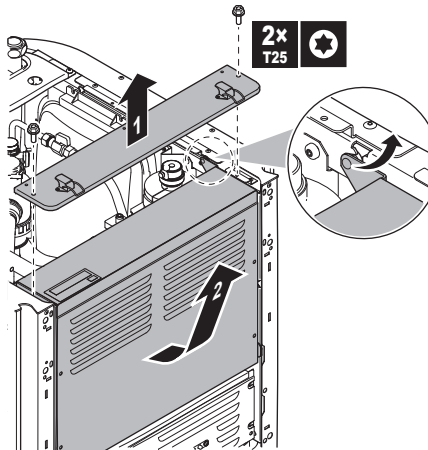

- 3 Place the switch box lower on the unit. Use the 2 hinges located lower on the unit.

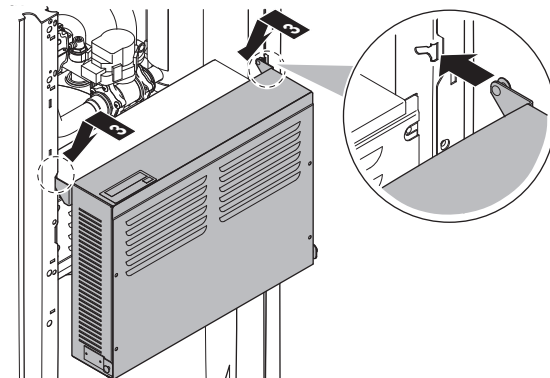

4.2 Mounting the indoor unit

4.2.1 To install the indoor unit

- 1 Lift the indoor unit from the pallet and place it on the floor. Also see "2.1.2 To handle the indoor unit" on page 5.
- 2 Connect the drain hose to the drain. See "4.2.2 To connect the drain hose to the drain" on page 9.
- 3 Slide the indoor unit into position.
- 4 Adjust the height of the leveling feet to compensate for floor irregularities. The maximum allowed deviation is 1° .

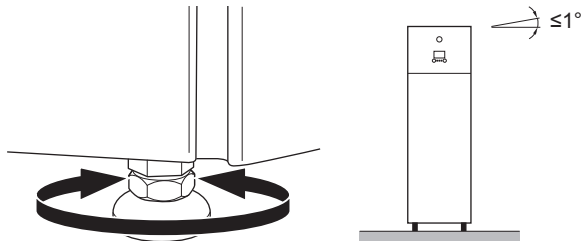

NOTICE

Do NOT tilt the unit forwards:

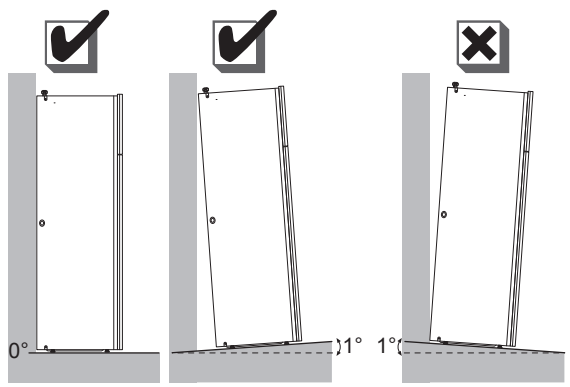

4.2.2 To connect the drain hose to the drain

Water coming from the pressure relief valve is collected in the drain pan. The drain pan is connected to a drain hose inside the unit. You must connect the drain hose to an appropriate drain according to the applicable legislation. You can route the drain hose through the left or right side panel.

Prerequisite: The user interface panel and front panel have been removed.

- 1 Remove one of the side panels.
- 2 Cut out the rubber grommet.
- 3 Pull the drain hose through the hole.
- 4 Reattach the side panel. Ensure the water can flow through the drain tube.

It is recommended to use a tundish to collect the water.

Option 1: Through the left side panel

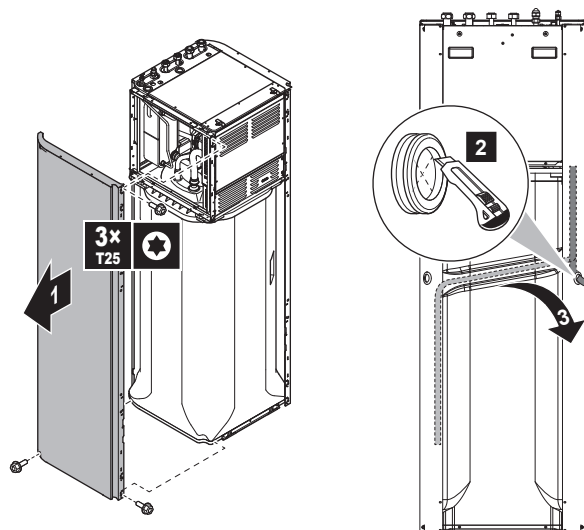

Option 2: Through the right side panel

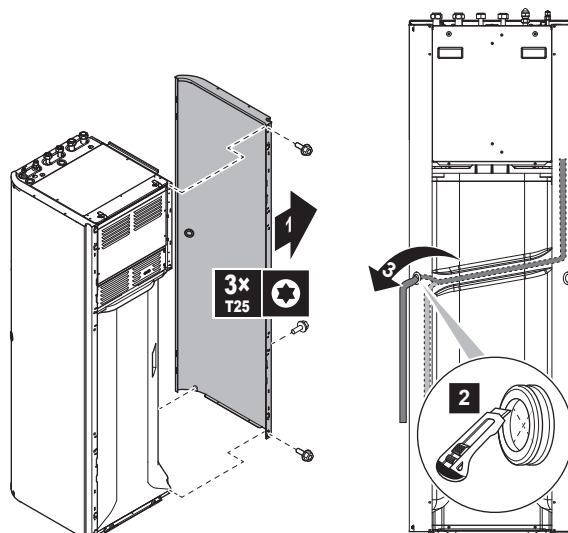

4.3 Connecting the refrigerant piping

See the outdoor unit installation manual for all guidelines, specifications and installation instructions.

4.3.1 To connect the refrigerant piping to the indoor unit

- 1 Connect the liquid stop valve from the outdoor unit to the refrigerant liquid connection of the indoor unit.

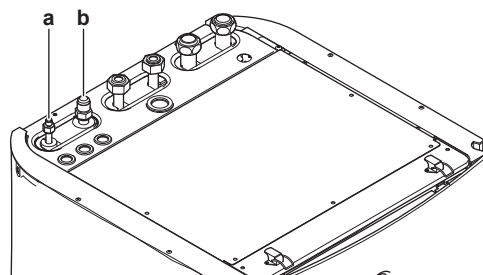

- a Refrigerant liquid connection
- b Refrigerant gas connection

- 2 Connect the gas stop valve from the outdoor unit to the refrigerant gas connection of the indoor unit.

4 Installation

i INFORMATION

When the indoor unit is installed in a place with limited space, an optional pipe bend (EKHVTC) kit can be installed to facilitate the connection to the refrigerant gas and liquid connections of the indoor unit. For installation instructions, see the instruction sheet of the pipe bend kit.

4.4 Connecting the water piping

4.4.1 To connect the water piping

! NOTICE

Do NOT use excessive force when connecting the piping. Deformation of the piping can cause malfunctioning of the unit.

To facilitate service and maintenance, 2 shut-off valves and 1 overpressure bypass valve are provided. Mount the shut-off valves on the space heating water inlet and space heating water outlet. To ensure the minimum flow rate (and prevent overpressure), install the overpressure bypass valve on the space heating water outlet.

- 1 Install the shut-off valves on the space heating water pipes.
- 2 Screw the indoor unit nuts on the shut-off valve.
- 3 Connect the domestic hot water in and out pipes to the indoor unit.

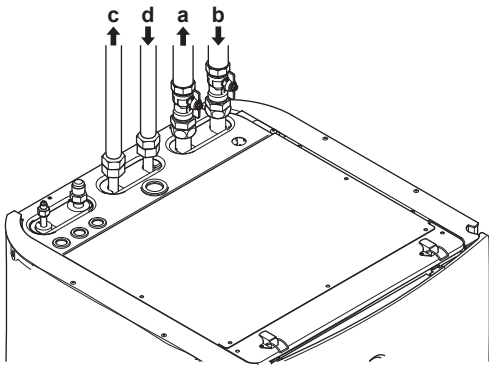

- a Space heating/cooling water out
- b Space heating/cooling water in
- c Domestic hot water out
- d Domestic cold water in (cold water supply)

! NOTICE

It is recommended to install shut-off valves to domestic cold water in and domestic hot water out connections. These shut-off valves are field supplied.

! NOTICE



Overpressure bypass valve (delivered as accessory). We recommend to install the overpressure bypass valve in the space heating water circuit.

Mind the minimum flow rate when adjusting the overpressure bypass valve setting. See "3.2.1 To check the water volume and flow rate" on page 7 and "6.2.1 To check the minimum flow rate" on page 22.

! NOTICE

Install air purge valves at all local high points.

! NOTICE

A pressure relief valve (field supply) with an opening pressure of maximum 10 bar (= 1 MPa) must be installed on the domestic cold water inlet connection in accordance with the applicable legislation.

4.4.2 To connect the recirculation piping

Prerequisite: Only required if you need recirculation in your system.

- 1 Remove the top panel from the unit, see "4.1.1 To open the indoor unit" on page 7.
- 2 Cut out the rubber grommet on top of the unit, and remove the stop. The recirculation connector is placed below the hole.
- 3 Route the recirculation piping through the grommet and connect it to the recirculation connector.

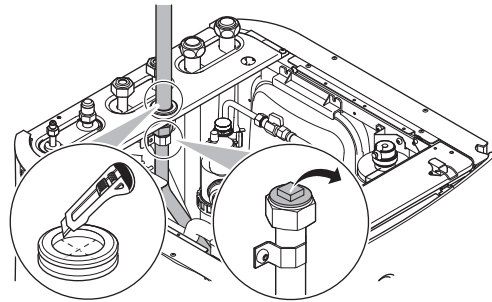

- 4 Reattach the top panel.

4.4.3 To fill the water circuit

To fill the water circuit, use a field supply filling kit. Make sure you comply with the applicable legislation.

i INFORMATION

Make sure both air purge valves (one on the magnetic filter and one on the backup heater) are open.

4.4.4 To fill the domestic hot water tank

- 1 Open every hot water tap in turn to purge air from the system pipe work.
- 2 Open the cold water supply valve.
- 3 Close all water taps after all air is purged.
- 4 Check for water leaks.
- 5 Manually operate the field-installed pressure relief valve to ensure a free water flow through the discharge pipe.

4.4.5 To insulate the water piping

The piping in the complete water circuit **MUST** be insulated to prevent condensation during cooling operation and reduction of the heating and cooling capacity.

If the temperature is higher than 30°C and the humidity is higher than RH 80%, the thickness of the insulation materials should be at least 20 mm to prevent condensation on the surface of the insulation.

4.5 Connecting the electrical wiring

⚡ DANGER: RISK OF ELECTROCUTION

⚠ WARNING
ALWAYS use multicore cable for power supply cables.

4.5.1 About electrical compliance

Only for the backup heater of the indoor unit

See "4.5.4 To connect the backup heater power supply" on page 12.

4.5.2 To connect the electrical wiring on the indoor unit

- 1 To open the indoor unit, see "4.1.1 To open the indoor unit" on page 7 and "4.1.2 To open the switch box cover of the indoor unit" on page 8.
- 2 The wiring enters the unit from the top:

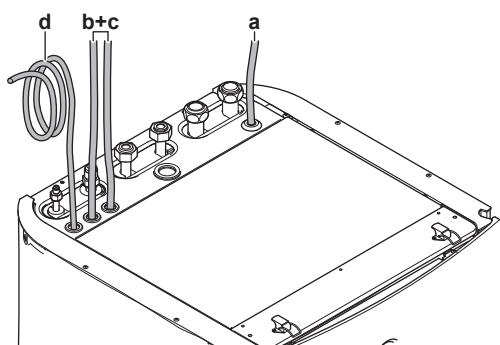

a, b, c Field wiring (see table below)
d Factory-mounted cable for power supply of backup heater

- 3 Routing of the wiring inside the unit should be as follows. Fix the cable to the cable rail using cable ties:

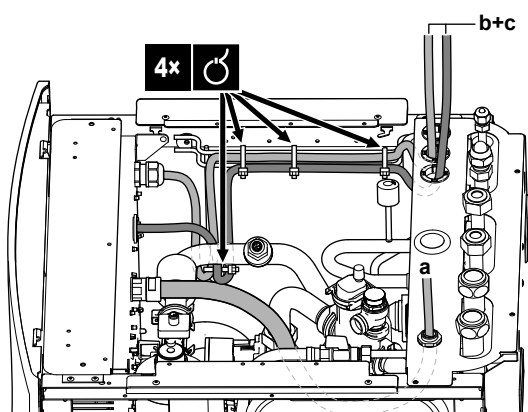

WARNING

Make sure that the electrical wiring does NOT touch the refrigerant gas pipe, which can be very hot.

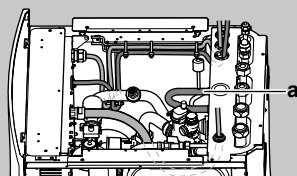

a Refrigerant gas pipe

| Routing | Possible cables (depending on unit type and installed options) |
|--|--|
| a Low voltage | <ul style="list-style-type: none"> ▪ Preferential power supply contact ▪ User interface used as room thermostat (option) ▪ Power consumption digital inputs (field supply) ▪ Outdoor ambient temperature sensor (option) ▪ Indoor ambient temperature sensor (option) ▪ Electrical meters (field supply) ▪ Safety thermostat (field supply) |
| b High voltage power supply | <ul style="list-style-type: none"> ▪ Interconnection cable ▪ Normal kWh rate power supply ▪ Preferential kWh rate power supply |
| c High voltage control signal | <ul style="list-style-type: none"> ▪ Heat pump convector (option) ▪ Room thermostat (option) ▪ Shut-off valve (field supply) ▪ Domestic hot water pump (field supply) ▪ Alarm output ▪ Changeover to external heat source control ▪ Space cool/heat operation control |
| d High voltage power supply (factory-mounted cable) | <ul style="list-style-type: none"> ▪ Power supply for backup heater |



CAUTION

Do NOT push or place redundant cable length in the unit.

- 4 Seal the low voltage wiring intake using the sealing tape (delivered as accessory).

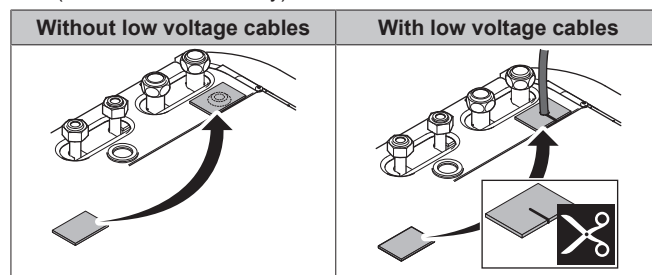

4.5.3 To connect the main power supply

- 1 Connect the main power supply.

In case of normal kWh rate power supply

4 Installation

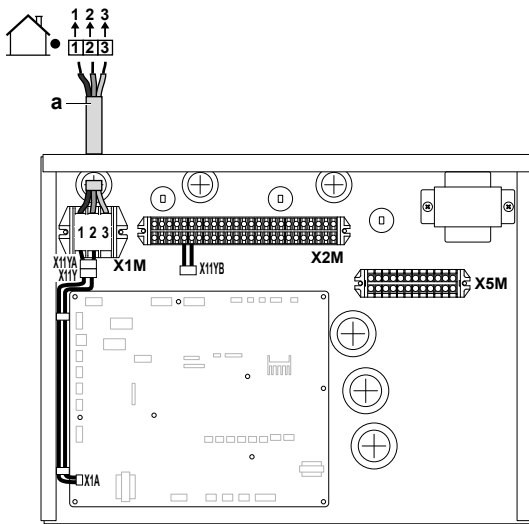

Legend: see illustration below.

In case of preferential kWh rate power supply

Connect X11Y to X11YB.

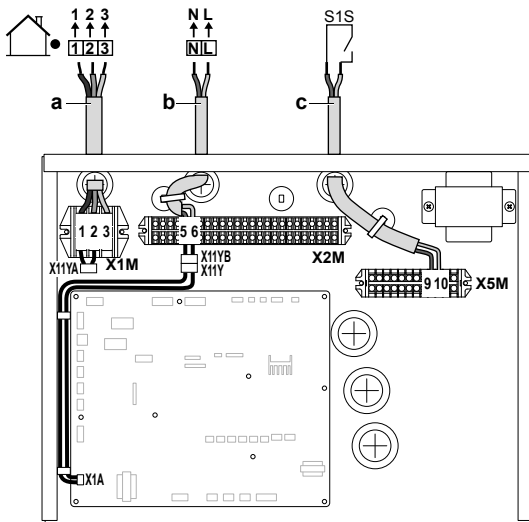

- a Interconnection cable (=main power supply)
- b Normal kWh rate power supply
- c Preferential power supply contact

2 Fix the cables with cable ties to the cable tie mountings.

i INFORMATION

In case of preferential kWh rate power supply, connect X11Y to X11YB. The necessity of separate normal kWh rate power supply to indoor unit (b) X2M/5+6 depends on the type of preferential kWh rate power supply.

Separate connection to the indoor unit is required:

- if preferential kWh rate power supply is interrupted when active, OR
- if no power consumption of the indoor unit is allowed at the preferential kWh rate power supply when active.

i INFORMATION

The preferential kWh rate power supply contact is connected to the same terminals (X5M/9+10) as the safety thermostat. It is only possible for the system to have EITHER preferential kWh rate power supply OR a safety thermostat.

4.5.4 To connect the backup heater power supply



WARNING

The backup heater **MUST** have a dedicated power supply and **MUST** be protected by the safety devices required by the applicable legislation.



CAUTION

To guarantee the unit is completely earthed, always connect the backup heater power supply and the earth cable.

The backup heater capacity can vary, depending on the indoor unit model. Make sure that the power supply is in accordance with the backup heater capacity, as listed in the table below.

| Backup heater type | Backup heater capacity | Power supply | Maximum running current | Z _{max} |
|--------------------|------------------------|--------------------------|-------------------------|------------------|
| *3V | 3 kW | 1N~ 230 V | 13 A ^(b) | 0.34 Ω |
| *6V | 2 kW | 1N~ 230 V ^(c) | 9 A | — |
| | 4 kW | 1N~ 230 V ^(c) | 17 A ^{(a)(b)} | 0.22 Ω |
| | 6 kW | 1N~ 230 V ^(c) | 26 A ^{(a)(b)} | 0.22 Ω |
| | 2 kW | 3~ 230 V ^(d) | 5 A | — |
| | 4 kW | 3~ 230 V ^(d) | 10 A | — |
| | 6 kW | 3~ 230 V ^(d) | 15 A | — |
| *9W | 3 kW | 3N~ 400 V | 4 A | — |
| | 6 kW | 3N~ 400 V | 9 A | — |
| | 9 kW | 3N~ 400 V | 13 A | — |

- (a) Equipment complying with EN/IEC 61000-3-12 (European/International Technical Standard setting the limits for harmonic currents produced by equipment connected to public low-voltage systems with input current >16 A and ≤75 A per phase.).
- (b) This equipment complies with EN/IEC 61000-3-11 (European/International Technical Standard setting the limits for voltage changes, voltage fluctuations and flicker in public low-voltage supply systems for equipment with rated current ≤75 A) provided that the system impedance Z_{sys} is less than or equal to Z_{max}, at the interface point between the user's supply and the public system. It is the responsibility of the installer or user of the equipment to ensure, by consultation with the distribution network operator if necessary, that the equipment is connected only to a supply with a system impedance Z_{sys} less than or equal to Z_{max}.
- (c) (6V)
- (d) (6T1)

Connect the backup heater power supply as follows:

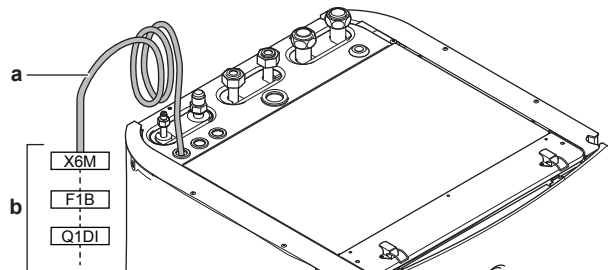

- a Factory-mounted cable connected to the backup heater contactor inside the switch box (K1M for *3V models; K5M for *6V and *9W models)
- b Field wiring (see table below)

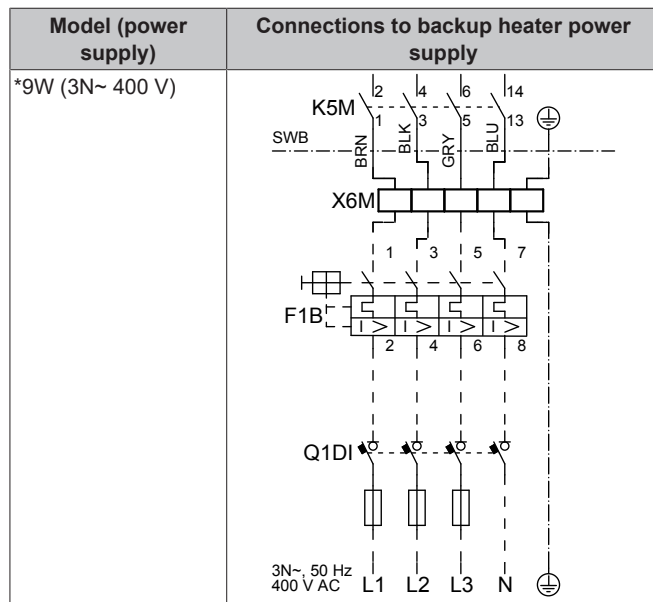
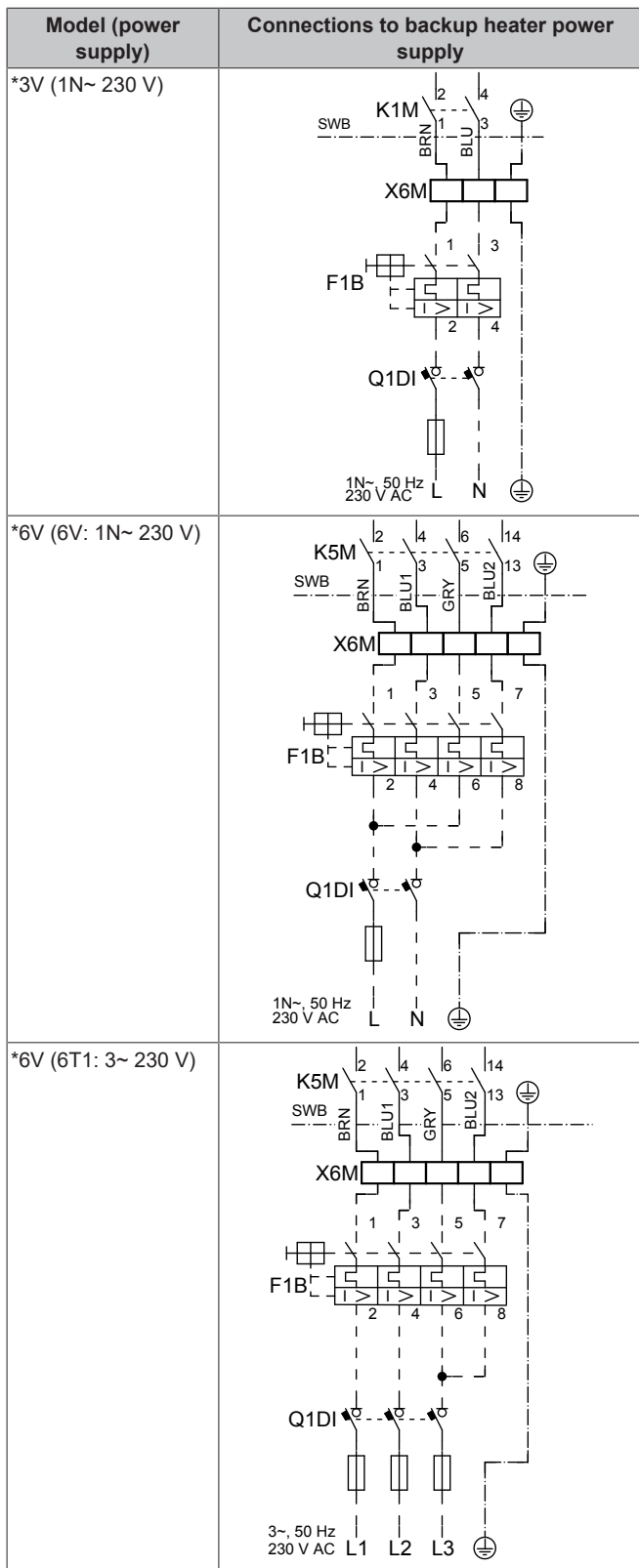

- F1B Overcurrent fuse (field supply). Recommended fuse for *3V models: 2-pole; 20 A; curve 400 V; tripping class C. Recommended fuse for *6V and *9W models: 4-pole; 20 A; curve 400 V; tripping class C.
- K1M Contactor (in the lower switch box)
- K5M Safety contactor (in the lower switch box)
- Q1DI Earth leakage circuit breaker (field supply)
- SWB Switch box
- X6M Terminal (field supply)



NOTICE

Do NOT cut or remove the backup heater power supply cable.

4.5.5 To connect the shut-off valve



INFORMATION

Shut-off valve usage example. In case of one LWT zone, and a combination of underfloor heating and heat pump convectors, install a shut-off valve before the underfloor heating to prevent condensation on the floor during cooling operation. For more information, see the installer reference guide.

- 1 Connect the valve control cable to the appropriate terminals as shown in the illustration below.



NOTICE

Wiring is different for a NC (normally closed) valve and a NO (normally open) valve.

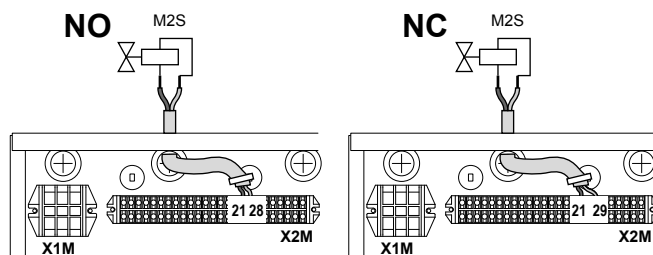

- 2 Fix the cable with cable ties to the cable tie mountings.

4.5.6 To connect the electricity meters



INFORMATION

In case of an electrical meter with transistor output, check the polarity. The positive polarity MUST be connected to X5M/6 and X5M/4; the negative polarity to X5M/5 and X5M/3.

4 Installation

- 1 Connect the electrical meters cable to the appropriate terminals as shown in the illustration below.

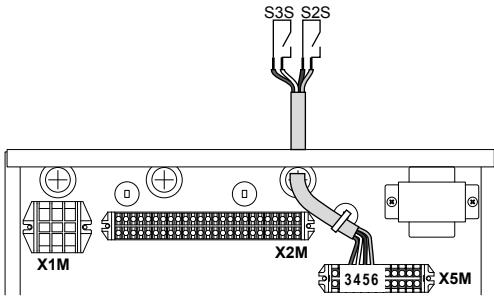

- 2 Fix the cable with cable ties to the cable tie mountings.

4.5.7 To connect the domestic hot water pump

- 1 Connect the domestic hot water pump cable to the appropriate terminals as shown in the illustration below.

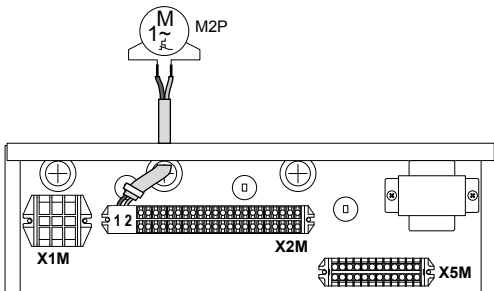

- 2 Fix the cable with cable ties to the cable tie mountings.

4.5.8 To connect the alarm output

- 1 Connect the alarm output cable to the appropriate terminals as shown in the illustration below.

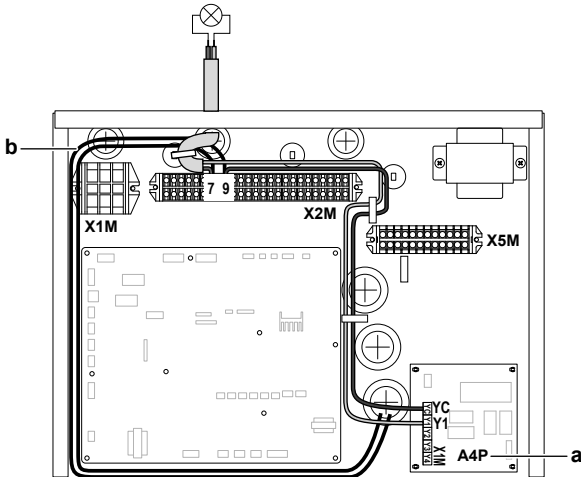

- a Installation of EKR1HB is required.
- b Prewiring between X2M/7+9 and Q1L (= thermal protector backup heater). Do NOT change.

- 2 Fix the cable with cable ties to the cable tie mountings.

4.5.9 To connect the space cooling/heating ON/OFF output

- 1 Connect the space cooling/heating ON/OFF output cable to the appropriate terminals as shown in the illustration below.

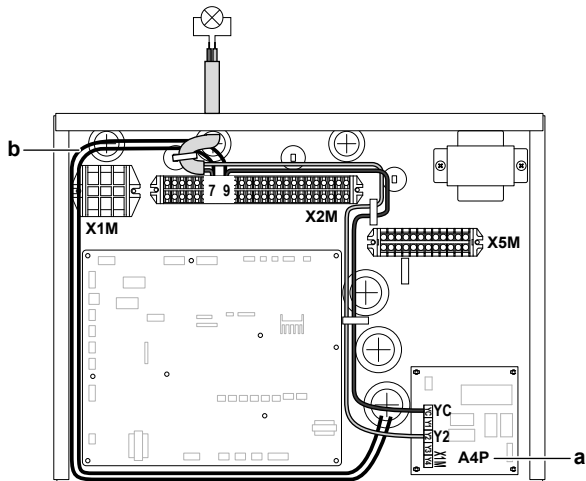

- a Installation of EKR1HB is required.
- b Prewiring between X2M/7+9 and Q1L (= thermal protector backup heater). Do NOT change.

- 2 Fix the cable with cable ties to the cable tie mountings.

4.5.10 To connect the changeover to external heat source

- 1 Connect the changeover to external heat source cable to the appropriate terminals as shown in the illustration below.

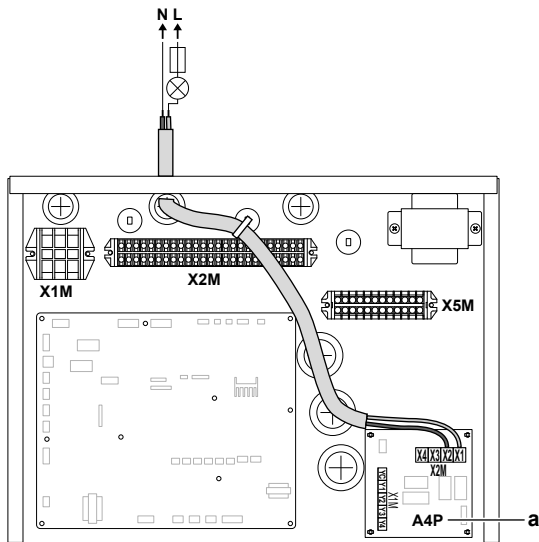

- a Installation of EKR1HB is required.

- 2 Fix the cable with cable ties to the cable tie mountings.

4.5.11 To connect the power consumption digital inputs

- 1 Connect the power consumption digital inputs cable to the appropriate terminals as shown in the illustration below.

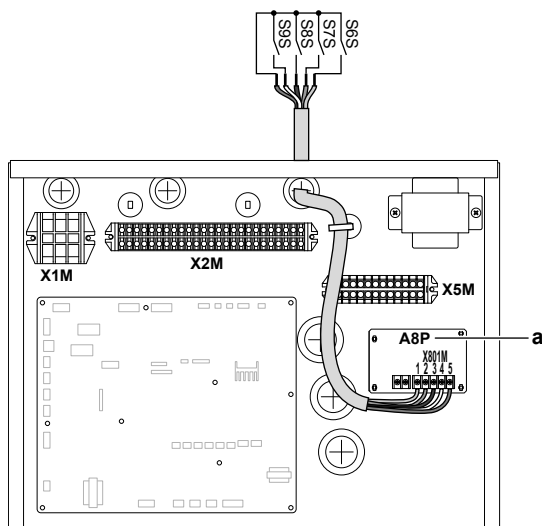

a Installation of EKRPIAHTA is required.

- 2 Fix the cable with cable ties to the cable tie mountings.

4.5.12 To connect the safety thermostat (normally closed contact)

- 1 Connect the safety thermostat (normally closed) cable to the appropriate terminals as shown in the illustration below.

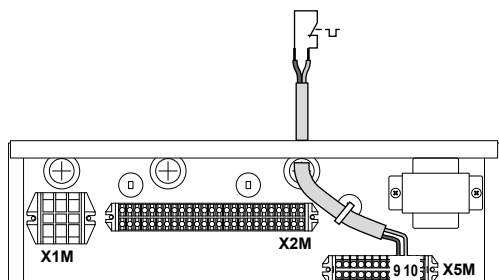

- 2 Fix the cable with cable ties to the cable tie mountings.

NOTICE

Make sure to select and install the safety thermostat according to the applicable legislation.

In any case, to prevent unnecessary tripping of the safety thermostat, we recommend the following:

- The safety thermostat is automatically resettable.
- The safety thermostat has a maximum temperature variation rate of 2°C/min.
- There is a minimum distance of 2 m between the safety thermostat and the 3-way valve.

INFORMATION

ALWAYS configure the safety thermostat after its installation. Without configuration, the indoor unit will ignore the safety thermostat contact.

INFORMATION

The preferential kWh rate power supply contact is connected to the same terminals (X5M/9+10) as the safety thermostat. It is only possible for the system to have EITHER preferential kWh rate power supply OR a safety thermostat.

4.6 Finishing the indoor unit installation

4.6.1 To close the indoor unit

- 1 Close the cover of the switch box.
- 2 Put the switch box back into place.
- 3 Reinstall the top panel.
- 4 Reinstall the side panels.
- 5 Reinstall the front panel.
- 6 Reconnect the cables to the user interface panel.
- 7 Reinstall the user interface panel.



NOTICE

When closing the indoor unit cover, make sure that the tightening torque does NOT exceed 4.1 N•m.

5 Configuration

5.1 Overview: Configuration

This chapter describes what you have to do and know to configure the system after it is installed.



NOTICE

The explanation about the configuration in this chapter gives you ONLY basic explanations. For more detailed explanation and background information, see the installer reference guide.

Why

If you do NOT configure the system correctly, it might NOT work as expected. The configuration influences the following:

- The calculations of the software
- What you can see on and do with the user interface

How

You can configure the system via the user interface.

- **First time – Configuration wizard.** When you turn ON the user interface for the first time (via the indoor unit), the configuration wizard starts to help you configure the system.
- **Restart the configuration wizard.** If the system is already configured, you can restart the configuration wizard. To restart the configuration wizard, go to `Installer settings > Configuration wizard`. To access `Installer settings`, see ["5.1.1 To access the most used commands" on page 16](#).
- **Afterwards.** If necessary, you can make changes to the configuration in the menu structure or the overview settings.



INFORMATION

When the configuration wizard is finished, the user interface will show an overview screen and request to confirm. When confirmed, the system will restart and the home screen will be displayed.

Accessing settings – Legend for tables

You can access the installer settings using two different methods. However, NOT all settings are accessible via both methods. If so, the corresponding table columns in this chapter are set to N/A (not applicable).

5 Configuration

| Method | Column in tables |
|---|---------------------------------------|
| Accessing settings via the breadcrumb in the home menu screen or the menu structure . To enable breadcrumbs, press the ? button in the home screen. | # For example: [9.1.5.2] |
| Accessing settings via the code in the overview field settings . | Code For example: [C-07] |

See also:

- "To access the installer settings" on page 16
- "5.4 Menu structure: Overview installer settings" on page 21

5.1.1 To access the most used commands

To change the user permission level

You can change the user permission level as follows:

| | | |
|---|--|---|
| 1 | Go to [B]: User profile. | |
| | | |
| 2 | Enter the applicable pin code for the user permission level. | — |
| | <ul style="list-style-type: none"> • Browse through the list of digits and change the selected digit. • Move the cursor from left to right. • Confirm the pin code and proceed. | |

Installer pin code

The Installer pin code is **5678**. Additional menu items and installer settings are now available.

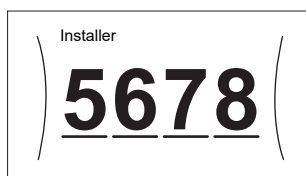

Advanced user pin code

The Advanced user pin code is **1234**. Additional menu items for the user are now visible.

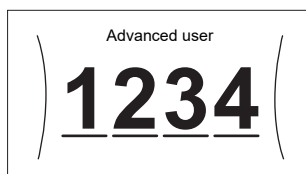

User pin code

The User pin code is **0000**.

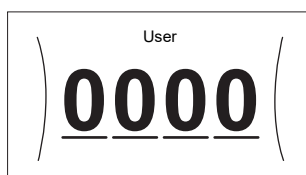

To access the installer settings

- 1 Set the user permission level to Installer.
- 2 Go to [9]: Installer settings.

To modify an overview setting

Example: Modify [1-01] from 15 to 20.

Most settings can be configured via the menu structure. If for any reason it is required to change a setting using the overview settings, then the overview settings can be accessed as follows:

| | | |
|---|---|---|
| 1 | Set the user permission level to Installer. See " To change the user permission level " on page 16. | — |
| 2 | Go to [9.]: Installer settings > Overview field settings. | |
| 3 | Turn the left dial to select the first part of the setting and confirm by pressing the dial. | |
| | | |
| 4 | Turn the left dial to select the second part of the setting | |
| | | |
| 5 | Turn the right dial to modify the value from 15 to 20. | |
| | | |
| 6 | Press the left dial to confirm the new setting. | |
| 7 | Press the center button to go back to the home screen. | |



INFORMATION

When you change the overview settings and you go back to the home screen, the user interface will show a popup screen and request to restart the system.

When confirmed, the system will restart and recent changes will be applied.

5.2 Configuration wizard

After first power ON of the system, the user interface will guide you using the configuration wizard. This way you can set the most important initial settings. This way the unit will be able to run properly. Afterwards, more detailed settings can be done via the menu structure if required.

5.2.1 Configuration wizard: Language

| # | Code | Description |
|-------|------|-------------|
| [7.1] | N/A | Language |

5.2.2 Configuration wizard: Time and date

| # | Code | Description |
|-------|------|-----------------------------|
| [7.2] | N/A | Set the local time and date |

i INFORMATION

By default, daylight savings time is enabled and clock format is set to 24 hours. If you want to change these settings, you can do this in the menu structure (User settings > Time/date) once the unit is initialised.

5.2.3 Configuration wizard: System

Indoor unit type

The indoor unit type is displayed, but cannot be adjusted.

Backup heater type

The backup heater is adapted to be connected to most common European electricity grids. The type of backup heater must be set on the user interface. For units with a built-in backup heater, the type of heater can be viewed but not changed.

| # | Code | Description |
|---------|--------|---|
| [9.3.1] | [E-03] | <ul style="list-style-type: none"> ▪ 2: 3V ▪ 3: 6V ▪ 4: 9W |

Domestic hot water

The following setting determines if the system can prepare domestic hot water or not, and which tank is used. This setting is read only.

| # | Code | Description |
|---------|---|---|
| [9.2.1] | [E-05] ^(*) [E-06] ^(*) [E-07] ^(*) | <ul style="list-style-type: none"> ▪ Integrated The backup heater will also be used for domestic hot water heating. |

(*) Menu structure setting [9.2.1] replaces the following 3 overview settings:

- [E-05] Can the system prepare domestic hot water?
- [E-06] Is a domestic hot water tank installed in the system?
- [E-07] What kind of domestic hot water tank is installed?

Emergency

When the heat pump fails to operate, the backup heater can serve as an emergency heater. It then takes over the heat load either automatically or by manual interaction.

- When Emergency is set to Automatic and a heat pump failure occurs, the backup heater automatically takes over the domestic hot water production and space heating.
- When Emergency is set to Manual and a heat pump failure occurs, the domestic hot water heating and space heating stops. To manually recover it via the user interface, go to the Malfunctioning main menu screen and confirm whether the backup heater can take over the heat load or not.

We recommend to set Emergency to Automatic if the house is unattended for longer periods.

| # | Code | Description |
|-------|------|---|
| [9.5] | N/A | <ul style="list-style-type: none"> ▪ 0: Manual ▪ 1: Automatic |

i INFORMATION

The auto emergency setting can be set in the menu structure of the user interface only.

i INFORMATION

If a heat pump failure occurs and Emergency is set to Manual, the room frost protection function, the underfloor heating screed dryout function, and the water pipe antifreeze function will remain active even if the user does NOT confirm emergency operation.

Number of zones

The system can supply leaving water to up to 2 water temperature zones. During configuration, the number of water zones must be set.

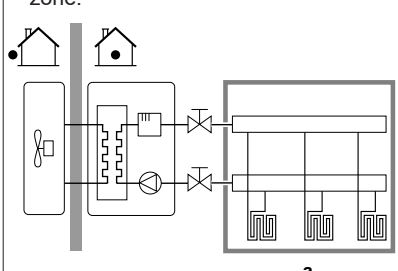
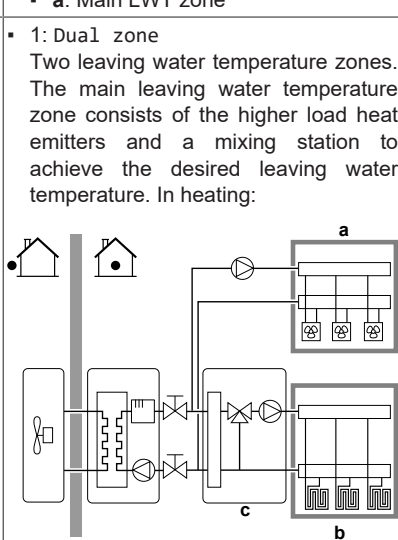
| # | Code | Description |
|-------|--------|---|
| [4.4] | [7-02] | <ul style="list-style-type: none"> ▪ 0: Single zone Only one leaving water temperature zone:  <ul style="list-style-type: none"> ▪ a: Main LWT zone |
| [4.4] | [7-02] | <ul style="list-style-type: none"> ▪ 1: Dual zone Two leaving water temperature zones. The main leaving water temperature zone consists of the higher load heat emitters and a mixing station to achieve the desired leaving water temperature. In heating:  <ul style="list-style-type: none"> ▪ a: Additional LWT zone: Highest temperature ▪ b: Main LWT zone: Lowest temperature ▪ c: Mixing station |

! CAUTION

If there are 2 zones, it is important that the zone with the lowest water temperature is configured as the main zone, and the zone with the highest water temperature is configured as the additional zone. Not configuring the system in this way could cause damage to the heat emitters.

! CAUTION

If there are 2 zones and the emitter types are wrongly configured, water of high temperature can be sent towards a low temperature emitter (underfloor heating). To avoid this:

- Install an aquastat/thermostatic valve to avoid too high temperatures towards a low temperature emitter.
- Make sure you set the emitter types for the main zone [2.7] and for the additional zone [3.7] correctly in accordance with the connected emitter.

! NOTICE

An overpressure bypass valve can be integrated in the system. Keep in mind that this valve might not be shown on the illustrations.

5 Configuration

5.2.4 Configuration wizard: Backup heater

The backup heater is adapted to be connected to most common European electricity grids. If the backup heater is available, the voltage, configuration and capacity must be set on the user interface.

The capacities for the different steps of the backup heater must be set for the energy metering and/or power consumption control feature to work properly. When measuring the resistance value of each heater, you can set the exact heater capacity and this will lead to more accurate energy data.

Voltage

- For a 3V model, this is fixed to 230V, 1ph.
- For a 6V model, this can be set to:
 - 230V, 1ph
 - 230V, 3ph
- For a 9W model, this is fixed to 400V, 3ph.

| # | Code | Description |
|---------|--------|--|
| [9.3.2] | [5-0D] | <ul style="list-style-type: none"> 0: 230V, 1ph 1: 230V, 3ph 2: 400V, 3ph |

Configuration

The backup heater can be configured in different ways. It can be chosen to have a 1-step only backup heater or a backup heater with 2 steps. If 2 steps, the capacity of the second step depends on this setting. It can also be chosen to have a higher capacity of the second step in emergency.

| # | Code | Description |
|---------|--------|--|
| [9.3.3] | [4-0A] | <ul style="list-style-type: none"> 0: Relay 1 1: Relay 1 / Relay 1+2^(a) 2: Relay 1 / Relay 2^(a) 3: Relay 1 / Relay 2 Emergency Relay 1+2^(a) |

(a) Not available for 3V models.



INFORMATION

Settings [9.3.3] and [9.3.5] are linked. Changing one setting influences the other. If you change one, check if the other is still as expected.



INFORMATION

During normal operation, the capacity of the second step of the backup heater at nominal voltage is equal to [6-03]+[6-04].



INFORMATION

If [4-0A]=3 and emergency mode is active, the power usage of the backup heater is maximal and equal to 2×[6-03]+[6-04].



INFORMATION

Only for systems with integrated domestic hot water tank: If the storage temperature set point is higher than 50°C, Daikin recommends NOT to disable the backup heater second step because it will have a big impact on the required time for the unit to heat up the domestic hot water tank.

Capacity step 1

| # | Code | Description |
|---------|--------|---|
| [9.3.4] | [6-03] | <ul style="list-style-type: none"> The capacity of the first step of the backup heater at nominal voltage. |

Additional capacity step 2

| # | Code | Description |
|---------|--------|--|
| [9.3.5] | [6-04] | <ul style="list-style-type: none"> The capacity difference between the second and first step of the backup heater at nominal voltage. Nominal value depends on backup heater configuration. |

5.2.5 Configuration wizard: Main zone

The most important settings for the main leaving water zone can be set here.

Emitter type

Depending on the system water volume and the heater emitter type of the main zone, heating up or cooling down the main zone can take longer. The setting Emitter type can compensate for a slow or a quick heating/cooling system during the heat up/cool down cycle. The target delta T for the main zone depends on this setting.

In room thermostat control, Emitter type influences the maximum modulation of the desired leaving water temperature, and the possibility for usage of the automatic cooling/heating changeover based on the indoor ambient temperature.

It is important to set Emitter type correctly and in accordance with your system layout.

| # | Code | Description |
|-------|--------|---|
| [2.7] | [2-0C] | <ul style="list-style-type: none"> 0: Underfloor heating 1: Fancoil unit 2: Radiator |

The setting of the emitter type has an influence on the space heating setpoint range and the target delta T in heating as follows:

| Description | Space heating setpoint range | Target delta T in heating |
|-----------------------|------------------------------|---------------------------|
| 0: Underfloor heating | Maximum 55°C | Variable |
| 1: Fancoil unit | Maximum 55°C | Variable |
| 2: Radiator | Maximum 65°C | Fixed 10°C |



NOTICE

For radiators, the average emitter temperature will be lower compared to underfloor heating, due to the fixed delta T of 10°C. To compensate, you can:

- Increase the weather dependent curve desired temperatures [2.5].
- Enable leaving water temperature modulation and increase the maximum modulation [2.C].

Control

Defines how the operation of the unit is controlled. There are 3 possibilities:

| Control | In this control... |
|--------------------------|---|
| Leaving water | Unit operation is decided based on the leaving water temperature regardless the actual room temperature and/or heating or cooling demand of the room. |
| External room thermostat | Unit operation is decided by the external thermostat or equivalent (e.g. heat pump convector). |
| Room thermostat | Unit operation is decided based on the ambient temperature of the user interface used as a room thermostat. |

| # | Code | Description |
|-------|--------|---|
| [2.9] | [C-07] | <ul style="list-style-type: none"> ▪ 0: Leaving water ▪ 1: External room thermostat ▪ 2: Room thermostat |

Setpoint mode

In Fixed mode, the desired leaving water temperature does NOT depend on the outdoor ambient temperature.

In WD heating, fixed cooling mode, the desired leaving water temperature:

- depends on the outdoor ambient temperature for heating
- does NOT depend on the outdoor ambient temperature for cooling

In Weather dependent mode, the desired leaving water temperature depends on the outdoor ambient temperature.

| # | Code | Description |
|-------|------|--|
| [2.4] | N/A | Setpoint mode <ul style="list-style-type: none"> ▪ 0: Fixed ▪ 1: WD heating, fixed cooling ▪ 2: Weather dependent |

When weather dependent operation is active, low outdoor temperatures will result in warmer water and vice versa. During weather dependent operation, the user has the possibility to shift the water temperature up or down by a maximum of 10°C.

Schedule

Indicates if the desired leaving water temperature is according to a schedule. Influence of the LWT setpoint mode [2.4] is as follows:

- In Fixed LWT setpoint mode, the scheduled actions consist of desired leaving water temperatures, either preset or custom.
- In Weather dependent LWT setpoint mode, the scheduled actions consist of desired shift actions, either preset or custom.

| # | Code | Description |
|-------|------|---|
| [2.1] | N/A | <ul style="list-style-type: none"> ▪ 0: No ▪ 1: Yes |

5.2.6 Configuration wizard: Additional zone

The most important settings for the additional leaving water zone can be set here.

Emitter type

For more info about this functionality, see "5.2.5 Configuration wizard: Main zone" on page 18.

| # | Code | Description |
|-------|--------|---|
| [3.7] | [2-0D] | <ul style="list-style-type: none"> ▪ 0: Underfloor heating ▪ 1: Fancoil unit ▪ 2: Radiator |

Control

The control type is displayed here, but cannot be adjusted. It is determined by the control type of the main zone. For more info about the functionality, see "5.2.5 Configuration wizard: Main zone" on page 18.

| # | Code | Description |
|-------|------|---|
| [3.9] | N/A | <ul style="list-style-type: none"> ▪ 0: Leaving water if the control type of the main zone is Leaving water. ▪ 1: External room thermostat if the control type of the main zone is External room thermostat or Room thermostat. |

Setpoint mode

For more info about this functionality, see "5.2.5 Configuration wizard: Main zone" on page 18.

| # | Code | Description |
|-------|------|--|
| [3.4] | N/A | <ul style="list-style-type: none"> ▪ 0: Fixed ▪ 1: WD heating, fixed cooling ▪ 2: Weather dependent |

If you choose WD heating, fixed cooling or Weather dependent, the next screen will be the detailed screen with weather-dependent curves. Also see "5.2.7 Detailed screen with weather-dependent curve" on page 19.

Schedule

Indicates if the desired leaving water temperature is according to a schedule. Also see "5.2.5 Configuration wizard: Main zone" on page 18.

| # | Code | Description |
|-------|------|---|
| [3.1] | N/A | <ul style="list-style-type: none"> ▪ 0: No ▪ 1: Yes |

5.2.7 Detailed screen with weather-dependent curve

When weather-dependent (WD) operation is active the desired leaving water or tank temperature is determined automatically depending on the averaged outdoor temperature. When the outdoor temperature is lower the leaving water or tank temperature will need to be higher as the water pipes will be colder and vice versa.

2-points WD curve

The weather-dependent curve is defined by two setpoints:

- Setpoint (X1, Y2)
- Setpoint (X2, Y1)

Weather-dependent curve:

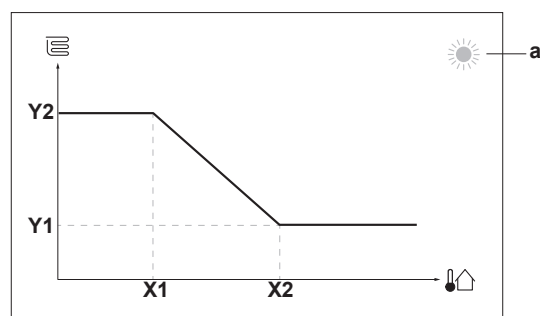

Possible actions on this screen

| | |
|--|------------------------------|
| | Go through the temperatures. |
| | Change the temperature. |
| | Go to the next temperature. |
| | Confirm changes and proceed. |

5 Configuration

| Item | Description |
|--------|---|
| a | Selected weather dependent zone: <ul style="list-style-type: none"> Main zone or additional zone heating Main zone or additional zone cooling Domestic hot water |
| X1, X2 | Examples of outdoor ambient temperature |
| Y1, Y2 | Examples of desired tank temperature or leaving water temperature. The icon corresponds to the heat emitter for that zone: <ul style="list-style-type: none"> Underfloor heating Fan coil unit Radiator Domestic hot water tank |

5.2.8 Configuration wizard: Tank

Heat up mode

The domestic hot water can be prepared in 3 different ways. They differ from each other by the way the desired tank temperature is set and how the unit acts upon it.

| # | Code | Description |
|-------|--------|---|
| [5.6] | [6-0D] | Heat up mode <ul style="list-style-type: none"> 0: Reheat only: Only reheat operation is allowed. 1: Schedule + reheat: The domestic hot water tank is heated according to a schedule and between the scheduled heat up cycles, reheat operation is allowed. 2: Schedule only: The domestic hot water tank can ONLY be heated according to a schedule. |

See the operation manual for more details.

Comfort setpoint

Only applicable when domestic hot water preparation is Schedule only or Schedule + reheat. When programming the schedule, you can make use of the comfort setpoint as a preset value. When you later want to change the storage setpoint, you only have to do it in one place.

The tank will heat up until the **storage comfort temperature** has been reached. It is the higher desired temperature when a storage comfort action is scheduled.

Additionally, a storage stop can be programmed. This feature puts a stop to tank heating even if the setpoint has NOT been reached. Only program a storage stop when tank heating is absolutely undesirable.

| # | Code | Description |
|-------|--------|--|
| [5.2] | [6-0A] | Comfort setpoint <ul style="list-style-type: none"> 30°C~[6-0E]°C |

Eco setpoint

The **storage economic temperature** denotes the lower desired tank temperature. It is the desired temperature when a storage economic action is scheduled (preferably during day).

| # | Code | Description |
|-------|--------|--|
| [5.3] | [6-0B] | Eco setpoint <ul style="list-style-type: none"> 30°C~min(50,[6-0E])°C |

Reheat setpoint

Desired reheat tank temperature, used:

- in Schedule + reheat mode, during reheat mode: the guaranteed minimum tank temperature is set by the Reheat setpoint minus the reheat hysteresis. If the tank temperature drops below this value, the tank is heated up.
- during storage comfort, to prioritize the domestic hot water preparation. When the tank temperature rises above this value, domestic hot water preparation and space heating/cooling are executed sequentially.

| # | Code | Description |
|-------|--------|---|
| [5.4] | [6-0C] | Reheat setpoint <ul style="list-style-type: none"> 30°C~min(50,[6-0E])°C |

5.3 Settings menu

You can set additional settings using the main menu screen and its submenus. The most important settings are presented here.

5.3.1 Main zone

Thermostat type

Only applicable in external room thermostat control.



NOTICE

If an external room thermostat is used, the external room thermostat will control the room frost protection. However, the room frost protection is only possible if [C.2] Space heating/cooling is turned ON.

| # | Code | Description |
|-------|--------|--|
| [2.A] | [C-05] | External room thermostat type for the main zone: <ul style="list-style-type: none"> 1: 1 contact: The used external room thermostat can only send a thermo ON/OFF condition. There is no separation between heating or cooling demand. 2: 2 contacts: The used external room thermostat can send a separate heating/cooling thermo ON/OFF condition. |

5.3.2 Additional zone

Thermostat type

Only applicable in external room thermostat control. For more info about the functionality, see "5.3.1 Main zone" on page 20.

| # | Code | Description |
|-------|--------|--|
| [3.A] | [C-06] | External room thermostat type for the additional zone: <ul style="list-style-type: none"> 1: 1 contact 2: 2 contacts |

5.3.3 Information

Dealer information

The installer can fill in his contact number here.

| # | Code | Description |
|-------|------|---|
| [8.3] | N/A | Number that users can call in case of problems. |

5.4 Menu structure: Overview installer settings

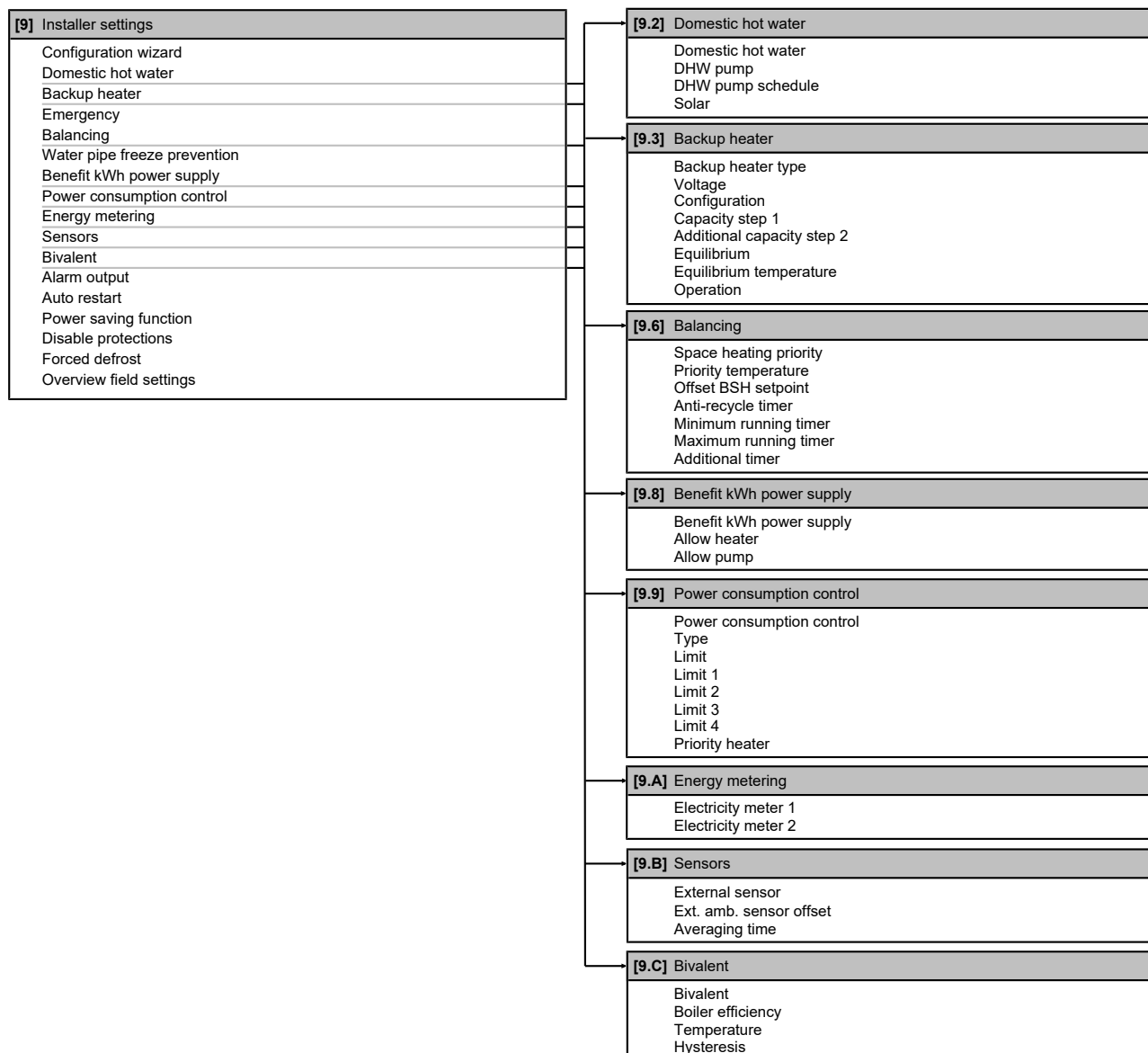

INFORMATION

Solar kit settings are shown but are NOT applicable for this unit. Settings shall NOT be used or changed.



INFORMATION

Depending on the selected installer settings and unit type, settings will be visible/invisible.

6 Commissioning

6 Commissioning



NOTICE

NEVER operate the unit without thermistors and/or pressure sensors/switches. Burning of the compressor might result.



INFORMATION

The software is equipped with an "installer-on-site" mode ([9.G]: Disable protections), that disables automatic operation by the unit. At first installation, setting Disable protections is by default set to Yes, meaning automatic operation is disabled. All protective functions are then disabled. If the user interface home pages are off, the unit will NOT operate automatically. To enable automatic operation and the protective functions, set Disable protections to No.

36 hours after the first power-on, the unit will automatically set Disable protections to No, ending "installer-on-site" mode and enabling the protective functions. If – after first installation – the installer returns to the site, the installer has to set Disable protections to Yes manually.

6.1 Checklist before commissioning

After the installation of the unit, first check the following items. Once all below checks are fulfilled, the unit MUST be closed, ONLY then can the unit be powered up.

| | |
|--------------------------|--|
| <input type="checkbox"/> | You read the complete installation instructions, as described in the installer reference guide . |
| <input type="checkbox"/> | The indoor unit is properly mounted. |
| <input type="checkbox"/> | The outdoor unit is properly mounted. |
| <input type="checkbox"/> | The following field wiring has been carried out according to this document and the applicable legislation: <ul style="list-style-type: none"> Between the local supply panel and the outdoor unit Between indoor unit and outdoor unit Between the local supply panel and the indoor unit Between the indoor unit and the valves (if applicable) Between the indoor unit and the room thermostat (if applicable) |
| <input type="checkbox"/> | The system is properly earthed and the earth terminals are tightened. |
| <input type="checkbox"/> | The fuses or locally installed protection devices are installed according to this document, and have NOT been bypassed. |
| <input type="checkbox"/> | The power supply voltage matches the voltage on the identification label of the unit. |
| <input type="checkbox"/> | There are NO loose connections or damaged electrical components in the switch box. |
| <input type="checkbox"/> | There are NO damaged components or squeezed pipes on the inside of the indoor and outdoor units. |
| <input type="checkbox"/> | Backup heater circuit breaker F1B (field supply) is turned ON. |
| <input type="checkbox"/> | There are NO refrigerant leaks . |
| <input type="checkbox"/> | The refrigerant pipes (gas and liquid) are thermally insulated. |
| <input type="checkbox"/> | The correct pipe size is installed and the pipes are properly insulated. |
| <input type="checkbox"/> | There is NO water leak inside the indoor unit. |

| | |
|--------------------------|---|
| <input type="checkbox"/> | The shut-off valves are properly installed and fully open. |
| <input type="checkbox"/> | The stop valves (gas and liquid) on the outdoor unit are fully open. |
| <input type="checkbox"/> | The air purge valve is open (at least 2 turns). |
| <input type="checkbox"/> | The pressure relief valve purges water when opened. |
| <input type="checkbox"/> | The domestic hot water tank is filled completely. |

6.2 Checklist during commissioning

| | |
|--------------------------|--|
| <input type="checkbox"/> | The minimum flow rate during backup heater/defrost operation is guaranteed in all conditions. See "To check the water volume and flow rate" in "3.2 Preparing water piping" on page 7 . |
| <input type="checkbox"/> | To perform an air purge . |
| <input type="checkbox"/> | To perform a test run . |
| <input type="checkbox"/> | To perform an actuator test run . |
| <input type="checkbox"/> | Underfloor screed dryout function The underfloor screed dryout function is started (if necessary). |

6.2.1 To check the minimum flow rate

| | | |
|---|--|---|
| 1 | Confirm according to the hydraulic configuration which space heating loops can be closed due to mechanical, electronic, or other valves. | — |
| 2 | Close all space heating loops that can be closed (see previous step). | — |
| 3 | Start the pump test run operation (see "6.2.4 To perform an actuator test run" on page 23). | — |
| 4 | During pump test run operation, go to Sensors. | |
| 5 | Select the flow rate information. During test run operation, the unit can operate below the minimum required flow rate. | |
| 6 | Modify the bypass valve setting to reach the minimum required flow rate + 2 l/min. | — |

Minimum required flow rate

12 l/min

6.2.2 To perform an air purge



Conditions: Make sure all operation is disabled. Go to the Operation menu and turn off Room, Space heating/cooling and Tank operation.

| | | |
|---|--|---|
| 1 | Set the user permission level to Installer. See "To change the user permission level" on page 16 . | — |
| 2 | Go to [A.3]: Commissioning > Air purge. | |
| 3 | Select OK to confirm. Result: The air purge starts. It stops automatically when air purge cycle is finished. | |
| | To stop the air purge manually: | — |
| 1 | Go to Stop air purge. | |
| 2 | Select OK to confirm. | |

Air purging heat emitters or collectors

We recommend to purge air with the unit's air purge function (see above). However, if you purge air from the heat emitters or collectors, mind the following:





WARNING

Air purging heat emitters or collectors. Before you purge air from heat emitters or collectors, check if  or  is displayed on the home screen of the user interface.

- If not, you can purge air immediately.
- If yes, make sure that the room where you want to purge air is sufficiently ventilated. **Reason:** Refrigerant might leak into the water circuit, and subsequently into the room when you purge air from the heat emitters or collectors.



6.2.3 To perform an operation test run

Conditions: Make sure all operation is disabled. Go to the Operation menu and turn off Room, Space heating/cooling and Tank operation.

| | | |
|--------------------------------|---|---|
| 1 | Set the user permission level to Installer. See "To change the user permission level" on page 16. | — |
| 2 | Go to [A.1]: Commissioning > Operation test run. |  |
| 3 | Select a test from the list. Example: Heating. |  |
| 4 | Select OK to confirm. Result: The test run starts. It stops automatically when done (±30 min). |  |
| To stop the test run manually: | | — |
| 1 | Go to Stop test run. |  |
| 2 | Select OK to confirm. |  |

If the installation of the unit has been done correctly, the unit will start up during test operation in the selected operation mode. During test mode, the correct operation of the unit can be checked by monitoring its leaving water temperature (heating/cooling mode) and tank temperature (domestic hot water mode).





To monitor the temperature:

| | | |
|---|-------------------------------------|---|
| 1 | Go to Sensors. |  |
| 2 | Select the temperature information. |  |

6.2.4 To perform an actuator test run

Conditions: Make sure all operation is disabled. Go to the Operation menu and turn off Room, Space heating/cooling and Tank operation.

Purpose of the actuator test run is to confirm the operation of the different actuators (e.g., when you select Pump, a test run of the pump will start).

| | | |
|--------------------------------|---|---|
| 1 | Set the user permission level to Installer. See "To change the user permission level" on page 16. | — |
| 2 | Go to [A.2]: Commissioning > Actuator test run. |  |
| 3 | Select a test from the list. Example: Pump. |  |
| 4 | Select OK to confirm. Result: The actuator test run starts. It stops automatically when done (±30 min). |  |
| To stop the test run manually: | | — |
| 1 | Go to Stop test run. |  |
| 2 | Select OK to confirm. |  |

Possible actuator test runs

- Backup heater 1 test
- Backup heater 2 test
- Pump test







INFORMATION

Make sure that all air is purged before executing the test run. Also avoid disturbances in the water circuit during the test run.

- Shut off valve test
- Diverter valve test
- Bivalent signal test
- Alarm output test
- C/H signal test
- DHW pump test

6.2.5 To perform an underfloor heating screed dryout

Conditions: Make sure all operation is disabled. Go to the Operation menu and turn off Room, Space heating/cooling and Tank operation.

| | | |
|--------------------------------|--|---|
| 1 | Set the user permission level to Installer. See "To change the user permission level" on page 16. | — |
| 2 | Go to [A.4]: Commissioning > UFH screed dryout. |  |
| 3 | Set a dryout program: go to Program and use the UFH screed dryout programming screen. |  |
| 4 | Select OK to confirm. Result: The underfloor heating screed dryout starts. It stops automatically when done. |  |
| To stop the test run manually: | | — |
| 1 | Go to Stop UFH screed dryout. |  |
| 2 | Select OK to confirm. |  |



NOTICE

To perform an underfloor heating screed dryout, room frost protection needs to be disabled ([2-06]=0). By default, it is enabled ([2-06]=1). However, due to the "installer-on-site" mode (see "Commissioning"), room frost protection will be automatically disabled for 36 hours after the first power-on.

If the screed dryout still needs to be performed after the first 36 hours of power-on, manually disable room frost protection by setting [2-06] to "0", and KEEP it disabled until the screed dryout has finished. Ignoring this notice will result in cracking of the screed.



NOTICE

For the underfloor heating screed dryout to be able to start, make sure the following settings are met:

- [4-00]=1
- [C-02]=0
- [D-01]=0
- [4-08]=0
- [4-01]≠1

7 Hand-over to the user

Once the test run is finished and the unit operates properly, please make sure the following is clear for the user:

7 Hand-over to the user

- Fill in the installer setting table (in the operation manual) with the actual settings.
- Make sure that the user has the printed documentation and ask him/her to keep it for future reference. Inform the user that he can find the complete documentation at the URL mentioned earlier in this manual.
- Explain the user how to properly operate the system and what to do in case of problems.
- Show the user what to do for the maintenance of the unit.
- Explain the user about energy saving tips as described in the operation manual.

8 Technical data

A **subset** of the latest technical data is available on the regional Daikin website (publicly accessible). The **full set** of latest technical data is available on the Daikin Business Portal (authentication required).

8.1 Piping diagram: Indoor unit

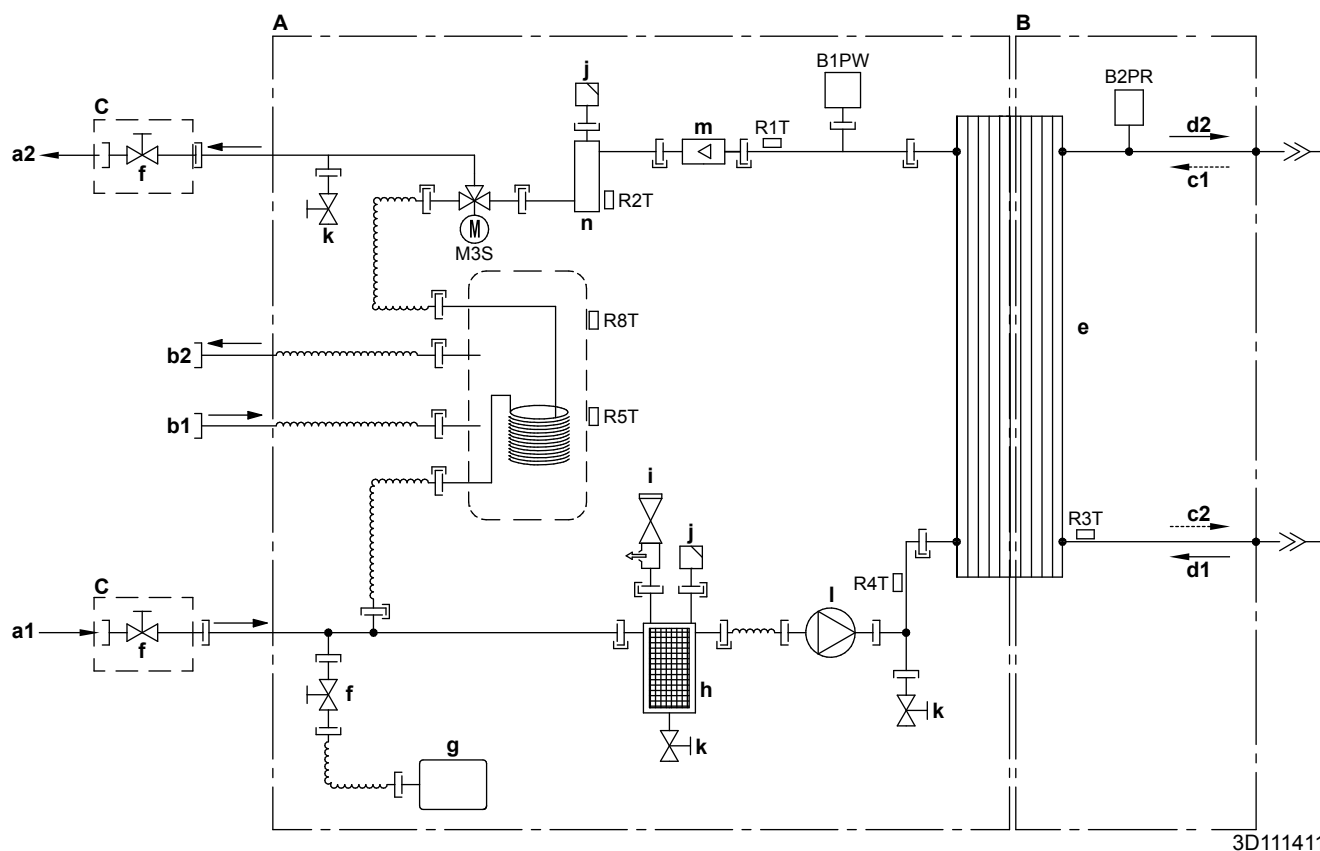

- | | | | |
|-----------|--|-----------------|--|
| A | Water side | B1PW | Space heating water pressure sensor |
| B | Refrigerant side | B2PR | Refrigerant pressure sensor |
| C | Field installed | M3S | 3-way valve (space heating/domestic hot water) |
| a1 | Space heating water IN | R1T | Thermistor (heat exchanger – water OUT) |
| a2 | Space heating water OUT | R2T | Thermistor (backup heater – water OUT) |
| b1 | Domestic hot water: cold water IN | R3T | Thermistor (liquid refrigerant) |
| b2 | Domestic hot water: hot water OUT | R4T | Thermistor (heat exchanger – water IN) |
| c1 | Gas refrigerant IN (heating mode; condenser) | R5T, R8T | Thermistor (tank) |
| c2 | Liquid refrigerant OUT (heating mode; condenser) | — | Screw connection |
| d1 | Liquid refrigerant IN (cooling mode; evaporator) | — | Flare connection |
| d2 | Gas refrigerant OUT (cooling mode; evaporator) | — | Quick coupling |
| e | Plate heat exchanger | — | Brazed connection |
| f | Shut-off valve for service (if equipped) | | |
| g | Expansion vessel | | |
| h | Magnetic filter/dirt separator | | |
| i | Safety valve | | |
| j | Air purge | | |
| k | Drain valve | | |
| l | Pump | | |
| m | Flow sensor | | |
| n | Backup heater | | |

8 Technical data

8.2 Wiring diagram: Indoor unit

See the internal wiring diagram supplied with the unit (on the inside of the indoor unit switch box cover). The abbreviations used are listed below.

Notes to go through before starting the unit

| English | Translation |
|---|--|
| Notes to go through before starting the unit | Notes to go through before starting the unit |
| X1M | Main terminal |
| X2M | Field wiring terminal for AC |
| X5M | Field wiring terminal for DC |
| X6M | Backup heater power supply terminal |
| ----- | Earth wiring |
| ----- | Field supply |
| ① | Several wiring possibilities |
| | Option |
| | Not mounted in switch box |
| | Wiring depending on model |
| | PCB |
| Note 1: Connection point of the power supply for the BUH/BSH should be foreseen outside the unit. | Note 1: Connection point of the power supply for the backup heater/booster heater should be foreseen outside the unit. |
| Backup heater power supply | Backup heater power supply |
| <input type="checkbox"/> 1N~, 230 V | <input type="checkbox"/> 1N~, 230 V |
| <input type="checkbox"/> 3~, 230 V | <input type="checkbox"/> 3~, 230 V |
| <input type="checkbox"/> 3N~, 400 V | <input type="checkbox"/> 3N~, 400 V |
| User installed options | User installed options |
| <input type="checkbox"/> LAN adapter | <input type="checkbox"/> LAN adapter |
| <input type="checkbox"/> Remote user interface | <input type="checkbox"/> User interface used as room thermostat |
| <input type="checkbox"/> Ext. indoor thermistor | <input type="checkbox"/> External indoor thermistor |
| <input type="checkbox"/> Ext outdoor thermistor | <input type="checkbox"/> External outdoor thermistor |
| <input type="checkbox"/> Digital I/O PCB | <input type="checkbox"/> Digital I/O PCB |
| <input type="checkbox"/> Demand PCB | <input type="checkbox"/> Demand PCB |
| Main LWT | Main leaving water temperature |
| <input type="checkbox"/> On/OFF thermostat (wired) | <input type="checkbox"/> On/OFF thermostat (wired) |
| <input type="checkbox"/> On/OFF thermostat (wireless) | <input type="checkbox"/> On/OFF thermostat (wireless) |
| <input type="checkbox"/> Ext. thermistor | <input type="checkbox"/> External thermistor |
| <input type="checkbox"/> Heat pump convector | <input type="checkbox"/> Heat pump convector |
| Add LWT | Additional leaving water temperature |
| <input type="checkbox"/> On/OFF thermostat (wired) | <input type="checkbox"/> On/OFF thermostat (wired) |
| <input type="checkbox"/> On/OFF thermostat (wireless) | <input type="checkbox"/> On/OFF thermostat (wireless) |
| <input type="checkbox"/> Ext. thermistor | <input type="checkbox"/> External thermistor |
| <input type="checkbox"/> Heat pump convector | <input type="checkbox"/> Heat pump convector |

Position in switch box

| English | Translation |
|------------------------|------------------------|
| Position in switch box | Position in switch box |

Legend

| | |
|-----|--|
| A1P | Main PCB |
| A2P | * On/OFF thermostat (PC=power circuit) |
| A3P | * Heat pump convector |
| A4P | * Digital I/O PCB |
| A8P | * Demand PCB |

| | |
|----------------|---|
| A9P | Status indicator |
| A10P | MMI (= user interface connected to the indoor unit) – Power supply unit PCB |
| A11P | MMI (= user interface connected to the indoor unit) – Main PCB |
| A12P | MMI display PCB |
| A13P | * LAN adapter |
| A14P | * User interface used as room thermostat – PCB |
| A15P | * Receiver PCB (wireless On/OFF thermostat) |
| B1L | Flow sensor |
| B1PR | Refrigerant pressure sensor |
| B1PW | Water pressure sensor |
| CN* (A4P) | * Connector |
| DS1 (A8P) | * DIP switch |
| E1H | Backup heater element (1 kW) |
| E2H | Backup heater element (2 kW) |
| E3H | Backup heater element (3 kW) |
| E*P (A9P) | Indication LED |
| F1B | # Overcurrent fuse backup heater |
| F1T | Thermal fuse backup heater |
| F1U, F2U (A4P) | * Fuse 5 A 250 V for digital I/O PCB |
| FU1 (A1P) | Fuse T 5 A 250 V for PCB |
| FU2 (A10P) | Fuse T 1.6 A 250 V for PCB |
| K1M, K2M | Contactator backup heater |
| K5M | Safety contactator backup heater |
| K*R (A1P-A4P) | Relay on PCB |
| M1P | Main supply pump |
| M2P | # Domestic hot water pump |
| M2S | # 2-way valve for cooling mode |
| M3S | 3-way valve for floorheating/domestic hot water |
| P1M | MMI display |
| PC (A15P) | * Power circuit |
| PHC1 (A4P) | * Optocoupler input circuit |
| Q1L | Thermal protector backup heater |
| Q4L | # Safety thermostat |
| Q*DI | # Earth leakage circuit breaker |
| R1H (A2P) | * Humidity sensor |
| R1T (A1P) | Outlet water heat exchanger thermistor |
| R1T (A2P) | * Ambient sensor On/OFF thermostat |
| R1T (A14P) | * Ambient sensor user interface |
| R2T (A1P) | Outlet backup heater thermistor |
| R2T (A2P) | * External sensor (floor or ambient) |
| R3T | Refrigerant liquid side thermistor |
| R4T | Inlet water thermistor |
| R5T, R8T | Domestic hot water thermistor |
| R6T | * External indoor or outdoor ambient thermistor |
| S1S | # Preferential kWh rate power supply contact |
| S2S | # Electrical meter pulse input 1 |
| S3S | # Electrical meter pulse input 2 |

| | | |
|------------------|---|---|
| S6S~S9S | * | Digital power limitation inputs |
| SS1 (A4P) | * | Selector switch |
| SW1~2 (A12P) | | Turn buttons |
| SW3~5 (A12P) | | Push buttons |
| TR1 | | Power supply transformer |
| X6M | # | Backup heater power supply terminal strip |
| X*, X*A, X*Y, Y* | | Connector |
| X*M | | Terminal strip |

* Optional
Field supply

Translation of text on wiring diagram

| English | Translation |
|---|---|
| (1) Main power connection | (1) Main power connection |
| For preferential kWh rate power supply | For preferential kWh rate power supply |
| Indoor unit supplied from outdoor | Indoor unit supplied from outdoor |
| Normal kWh rate power supply | Normal kWh rate power supply |
| Only for normal power supply (standard) | Only for normal power supply (standard) |
| Only for preferential kWh rate power supply (outdoor) | Only for preferential kWh rate power supply (outdoor) |
| Outdoor unit | Outdoor unit |
| Preferential kWh rate power supply contact: 16 V DC detection (voltage supplied by PCB) | Preferential kWh rate power supply contact: 16 V DC detection (voltage supplied by PCB) |
| SWB | Switch box |
| Use normal kWh rate power supply for indoor unit | Use normal kWh rate power supply for indoor unit |
| (2) Backup heater power supply | (2) Backup heater power supply |
| Only for *** | Only for *** |
| (3) User interface | (3) User interface |
| Only for LAN adapter | Only for the LAN adapter |
| Only for remote user interface | Only for the user interface used as room thermostat |
| (5) Ext. thermistor | (5) External thermistor |
| SWB | Switch box |
| (6) Field supplied options | (6) Field supplied options |
| 12 V DC pulse detection (voltage supplied by PCB) | 12 V DC pulse detection (voltage supplied by PCB) |
| 230 V AC supplied by PCB | 230 V AC supplied by PCB |
| Continuous | Continuous current |
| DHW pump output | Domestic hot water pump output |

| English | Translation |
|--|--|
| DHW pump | Domestic hot water pump |
| Electrical meters | Electrical meters |
| For safety thermostat | For safety thermostat |
| Inrush | Inrush current |
| Max. load | Maximum load |
| Normally closed | Normally closed |
| Normally open | Normally open |
| Safety thermostat contact: 16 V DC detection (voltage supplied by PCB) | Safety thermostat contact: 16 V DC detection (voltage supplied by PCB) |
| Shut-off valve | Shut-off valve |
| SWB | Switch box |
| (7) Option PCBs | (7) Option PCBs |
| Alarm output | Alarm output |
| Changeover to ext. heat source | Changeover to external heat source |
| Max. load | Maximum load |
| Min. load | Minimum load |
| Only for demand PCB option | Only for demand PCB option |
| Only for digital I/O PCB option | Only for digital I/O PCB option |
| Options: ext. heat source output, alarm output | Options: external heat source output, alarm output |
| Options: On/OFF output | Options: On/OFF output |
| Power limitation digital inputs: 12 V DC / 12 mA detection (voltage supplied by PCB) | Power limitation digital inputs: 12 V DC / 12 mA detection (voltage supplied by PCB) |
| Space C/H On/OFF output | Space cooling/heating On/OFF output |
| SWB | Switch box |
| (8) External On/OFF thermostats and heat pump convector | (8) External On/OFF thermostats and heat pump convector |
| Additional LWT zone | Additional leaving water temperature zone |
| Main LWT zone | Main leaving water temperature zone |
| Only for external sensor (floor/ambient) | Only for external sensor (floor or ambient) |
| Only for heat pump convector | Only for heat pump convector |
| Only for wired On/OFF thermostat | Only for wired On/OFF thermostat |
| Only for wireless On/OFF thermostat | Only for wireless On/OFF thermostat |

8 Technical data

Electrical connection diagram

For more details, please check the unit wiring.

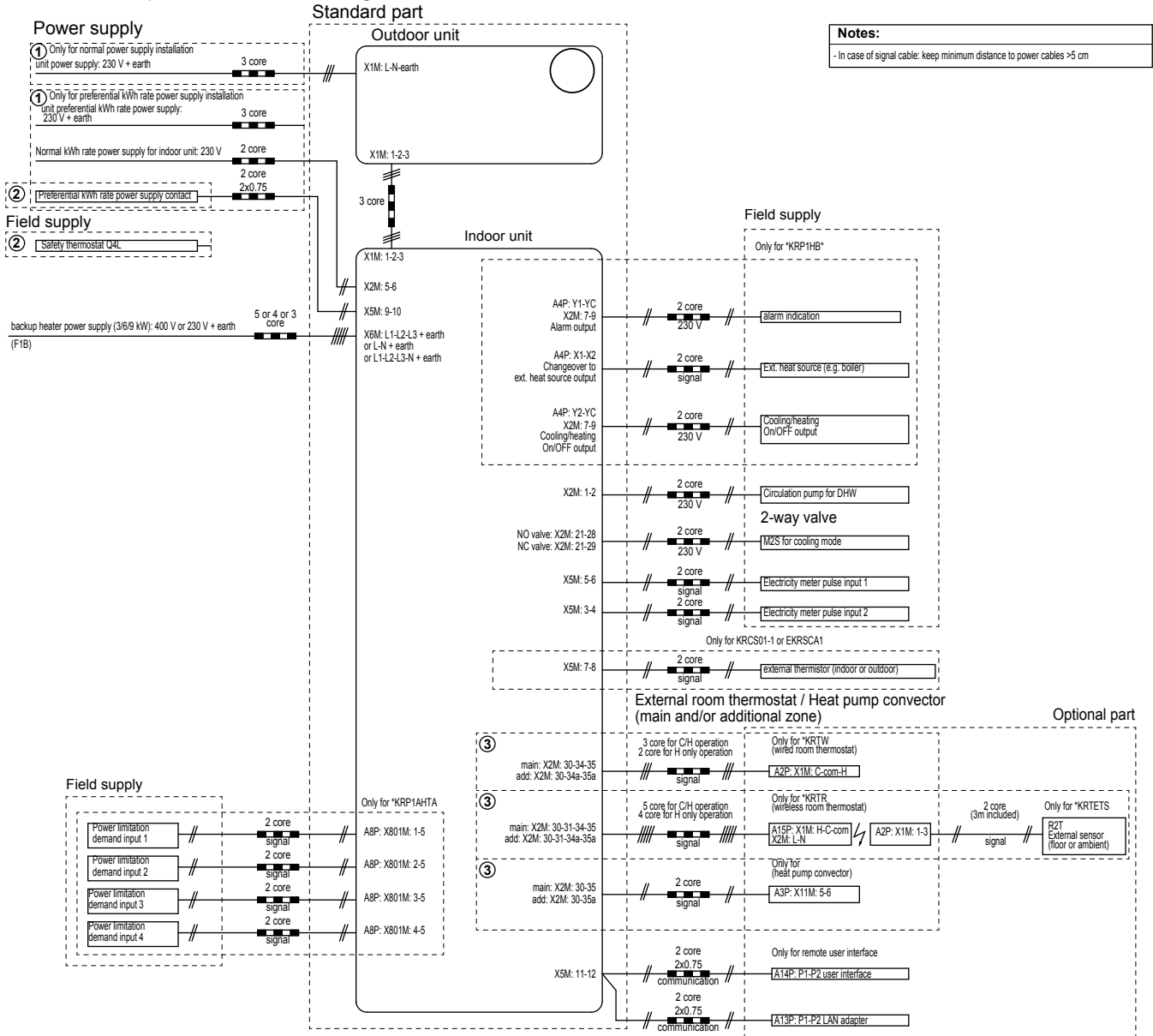

4D109881B

8.3 Table 1 – Maximum refrigerant charge allowed in a room: indoor unit

| A _{room} (m ²) | Maximum refrigerant charge in a room (m _{max}) (kg) |
|-------------------------------------|---|
| | H=600 mm |
| 1 | 0.138 |
| 2 | 0.276 |
| 3 | 0.414 |
| 4 | 0.553 |
| 5 | 0.691 |
| 6 | 0.829 |
| 7 | 0.907 |
| 8 | 0.970 |
| 9 | 1.028 |
| 10 | 1.084 |
| 11 | 1.137 |
| 12 | 1.187 |
| 13 | 1.236 |
| 14 | 1.283 |
| 15 | 1.328 |
| 16 | 1.371 |
| 17 | 1.413 |
| 18 | 1.454 |
| 19 | 1.494 |
| 20 | 1.533 |
| 21 | 1.571 |
| 22 | 1.608 |
| 23 | 1.644 |
| 24 | 1.679 |
| 25 | 1.714 |
| 26 | 1.748 |
| 27 | 1.781 |
| 28 | 1.814 |
| 29 | 1.846 |
| 30 | 1.877 |
| 31 | 1.909 |

i INFORMATION

- For floorstanding models, the value of "Installation height (H)" is considered 600 mm to comply to IEC 60335-2-40:2013 A1 2016 Clause GG2.
- For intermediate A_{room} values (i.e. when A_{room} is between two values from the table), consider the value that corresponds to the lower A_{room} value from the table. If A_{room}=12.5 m², consider the value that corresponds to "A_{room}=12 m²".

8.4 Table 2 – Minimum floor area: indoor unit

| m _c (kg) | Minimum floor area (m ²) |
|---------------------|--------------------------------------|
| | H=600 mm |
| 1.84 | 28.81 |
| 1.86 | 29.44 |
| 1.88 | 30.08 |
| 1.90 | 30.72 |

i INFORMATION

- For floorstanding models, the value of "Installation height (H)" is considered 600 mm to comply to IEC 60335-2-40:2013 A1 2016 Clause GG2.
- For intermediate m_c values (i.e. when m_c is between two values from the table), consider the value that corresponds to the higher m_c value from the table. If m_c=1.87 kg, consider the value that corresponds to "m_c=1.88 kg".
- Systems with a total refrigerant charge (m_c) <1.84 kg (i.e. if the piping length is <27 m) are NOT subjected to any requirements to the installation room.
- Charges >1.9 kg are NOT allowed in the unit.

8.5 Table 3 – Minimum venting opening area for natural ventilation: indoor unit

| m _c | m _{max} | dm=m _c -m _{max} (kg) | Minimum venting opening area (cm ²) |
|----------------|------------------|--|---|
| | | | H=600 mm |
| 1.9 | 0.1 | 1.80 | 729 |
| 1.9 | 0.3 | 1.60 | 648 |
| 1.9 | 0.5 | 1.40 | 567 |
| 1.9 | 0.7 | 1.20 | 486 |
| 1.9 | 0.9 | 1.00 | 418 |
| 1.9 | 1.1 | 0.80 | 370 |
| 1.9 | 1.3 | 0.60 | 301 |
| 1.9 | 1.5 | 0.40 | 216 |
| 1.9 | 1.7 | 0.20 | 115 |

i INFORMATION

- For floorstanding models, the value of "Installation height (H)" is considered 600 mm to comply to IEC 60335-2-40:2013 A1 2016 Clause GG2.
- For intermediate dm values (i.e. when dm is between two dm values from the table), consider the value that corresponds to the higher dm value from the table. If dm=1.55 kg, consider the value that corresponds to "dm=1.6 kg".

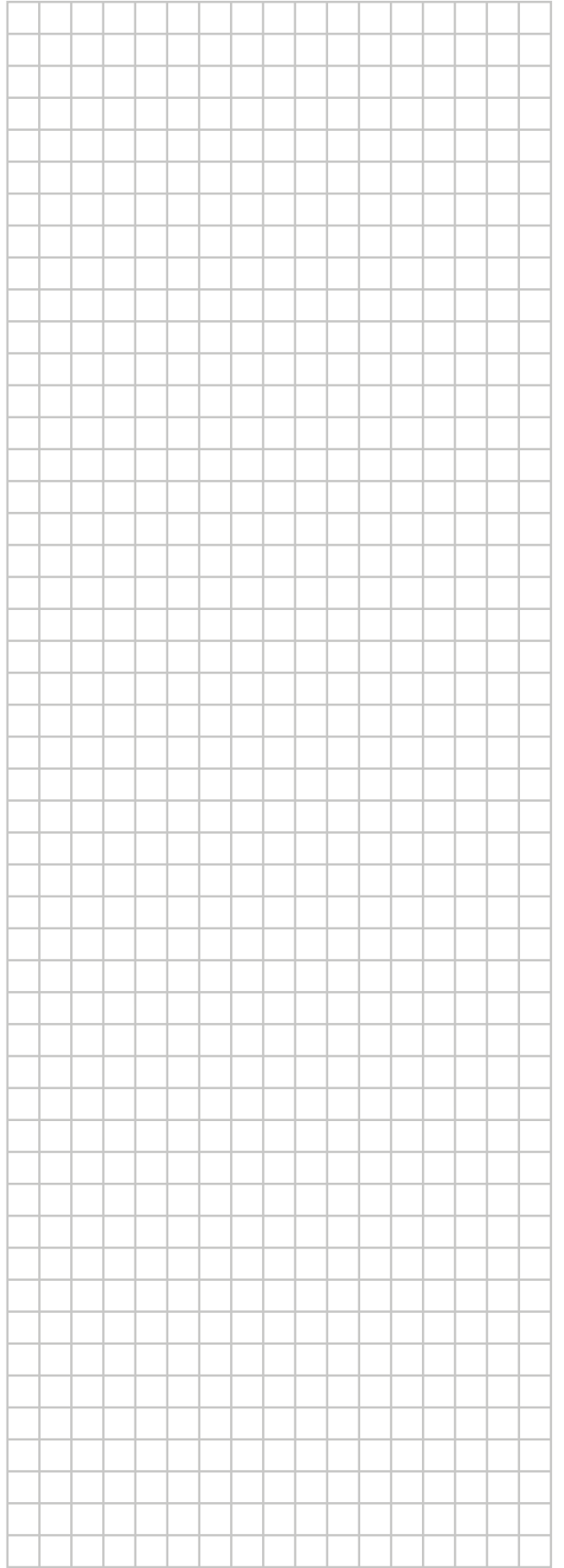
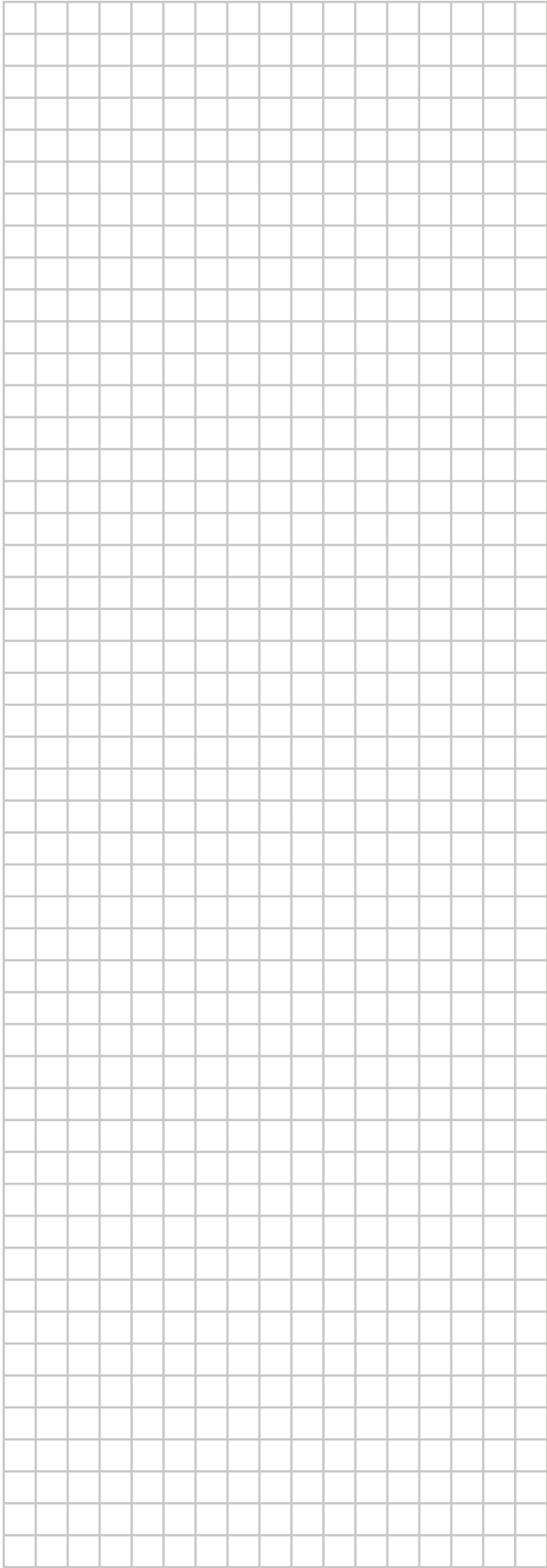

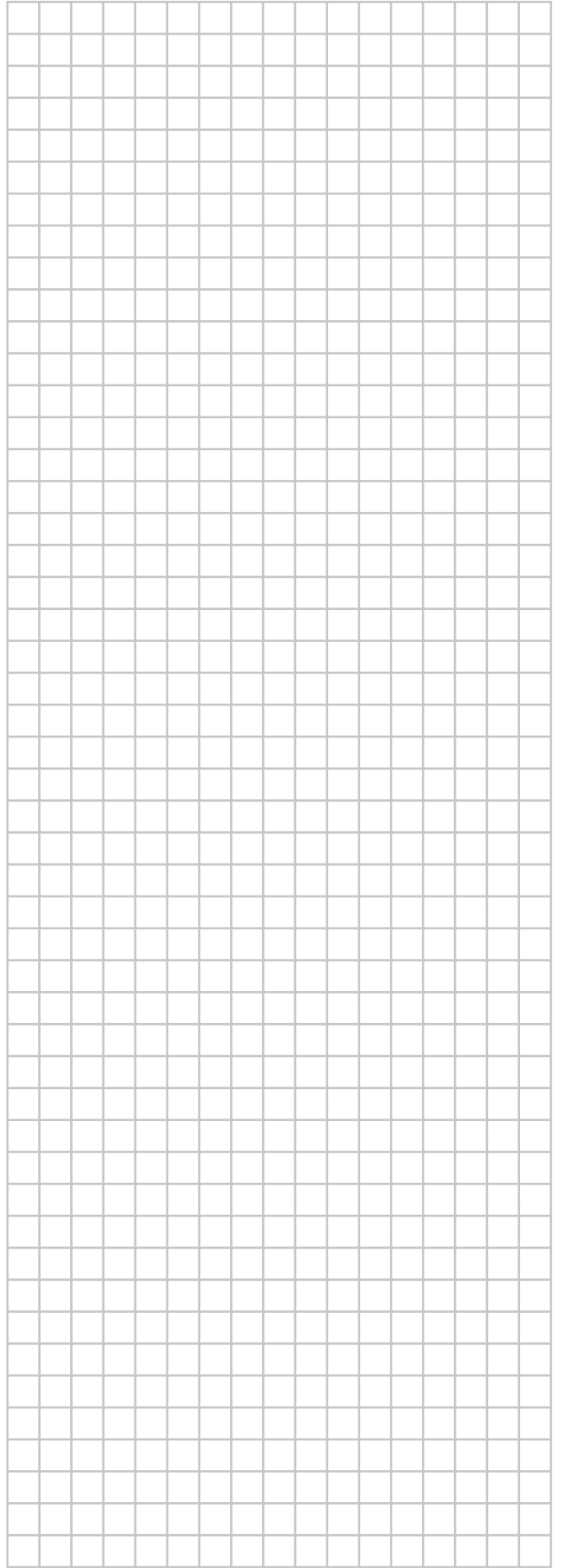
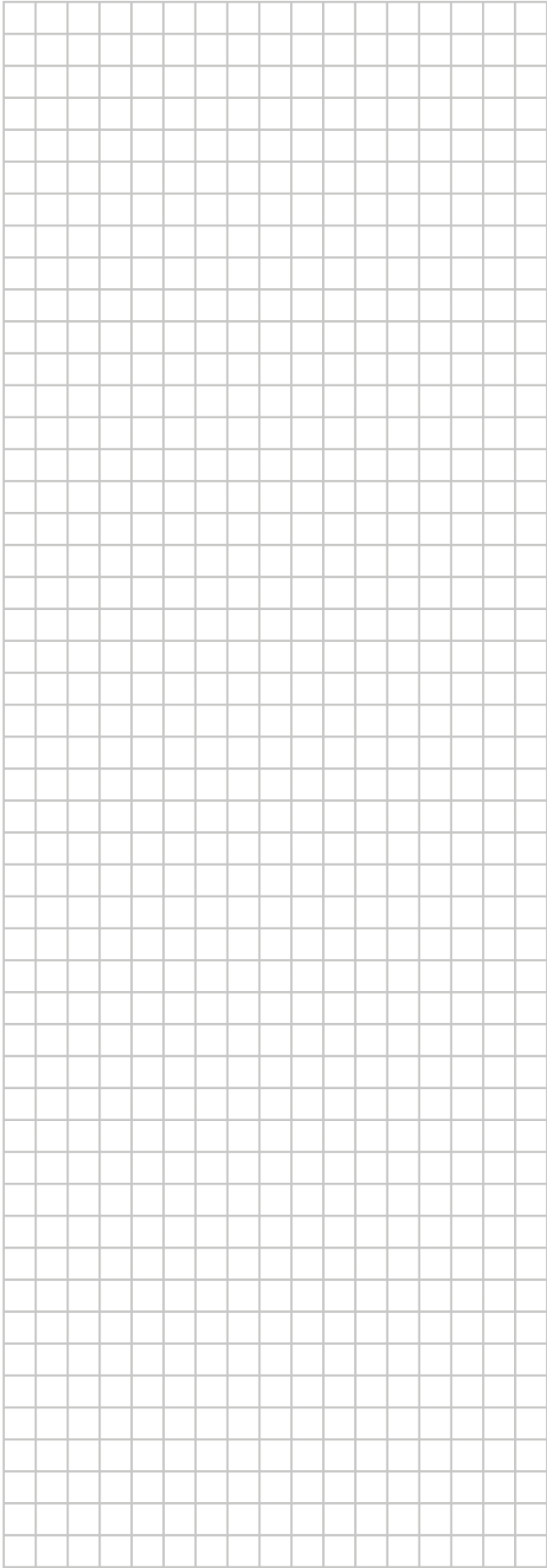

ERC



4P584428-1 0000000T

Copyright 2017 Daikin

DAIKIN EUROPE N.V.

Zandvoordestraat 300, B-8400 Oostende, Belgium

4P584428-1 2019.06