

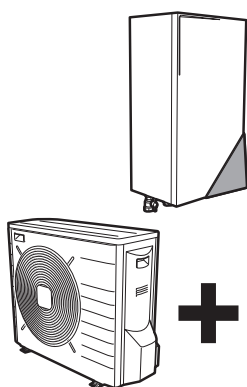

Installer reference guide

Daikin Altherma – Low temperature split



ERLQ004-006-008CA
EHBH/X04+08CB

Installer reference guide
Daikin Altherma – Low temperature split

English

Table of contents

1	General safety precautions	4	6.2.1	Installation site requirements of the outdoor unit	23
1.1	About the documentation	4	6.2.2	Additional installation site requirements of the outdoor unit in cold climates	24
1.1.1	Meaning of warnings and symbols	4	6.2.3	Installation site requirements of the indoor unit	24
1.2	For the installer	4	6.3	Preparing refrigerant piping	24
1.2.1	General	4	6.3.1	Refrigerant piping requirements	24
1.2.2	Installation site	4	6.3.2	Refrigerant piping insulation	25
1.2.3	Refrigerant	5	6.4	Preparing water piping	25
1.2.4	Brine	5	6.4.1	Water circuit requirements	25
1.2.5	Water	5	6.4.2	Formula to calculate the expansion vessel pre-pressure	26
1.2.6	Electrical	6	6.4.3	To check the water volume and flow rate	26
2	About the documentation	6	6.4.4	Changing the pre-pressure of the expansion vessel	27
2.1	About this document	6	6.4.5	To check the water volume: Examples	27
2.2	Installer reference guide at a glance	6	6.5	Preparing electrical wiring	27
3	About the box	7	6.5.1	About preparing electrical wiring	27
3.1	Overview: About the box	7	6.5.2	About preferential kWh rate power supply	28
3.2	Outdoor unit	7		Overview of electrical connections except external actuators	28
3.2.1	To unpack the outdoor unit	7	6.5.3	Overview of electrical connections for external and internal actuators	28
3.2.2	To remove the accessories from the outdoor unit	7	7	Installation	29
3.3	Indoor unit	8	7.1	Overview: Installation	29
3.3.1	To unpack the indoor unit	8	7.2	Opening the units	29
3.3.2	To remove the accessories from the indoor unit	8	7.2.1	About opening the units	29
4	About the units and options	9	7.2.2	To open the outdoor unit	29
4.1	Overview: About the units and options	9	7.2.3	To open the indoor unit	30
4.2	Identification	9	7.2.4	To open the switch box cover of the indoor unit	30
4.2.1	Identification label: Outdoor unit	9	7.3	Mounting the outdoor unit	30
4.2.2	Identification label: Indoor unit	9	7.3.1	About mounting the outdoor unit	30
4.3	Combining units and options	9	7.3.2	Precautions when mounting the outdoor unit	30
4.3.1	Possible options for the outdoor unit	9	7.3.3	To provide the installation structure	30
4.3.2	Possible options for the indoor unit	9	7.3.4	To install the outdoor unit	31
4.3.3	Possible combinations of indoor unit and outdoor unit	10	7.3.5	To provide drainage	32
4.3.4	Possible combinations of indoor unit and domestic hot water tank	11	7.3.6	To prevent the outdoor unit from falling over	32
5	Application guidelines	11	7.4	Mounting the indoor unit	33
5.1	Overview: Application guidelines	11	7.4.1	About mounting the indoor unit	33
5.2	Setting up the space heating/cooling system	11	7.4.2	Precautions when mounting the indoor unit	33
5.2.1	Single room	11	7.4.3	To install the indoor unit	33
5.2.2	Multiple rooms – One LWT zone	13	7.4.4	To install the drain pan kit	34
5.2.3	Multiple rooms – Two LWT zones	15	7.5	Connecting the refrigerant piping	34
5.3	Setting up an auxiliary heat source for space heating	16	7.5.1	About connecting the refrigerant piping	34
5.4	Setting up the domestic hot water tank	17	7.5.2	Precautions when connecting the refrigerant piping	34
5.4.1	System layout – Integrated DHW tank	17	7.5.3	Guidelines when connecting the refrigerant piping	34
5.4.2	System layout – Standalone DHW tank	18	7.5.4	Pipe bending guidelines	35
5.4.3	Selecting the volume and desired temperature for the DHW tank	18	7.5.5	To flare the pipe end	35
5.4.4	Setup and configuration – DHW tank	18	7.5.6	To braze the pipe end	35
5.4.5	Combination: Standalone DHW tank + Solar panels	19	7.5.7	Using the stop valve and service port	35
5.4.6	DHW pump for instant hot water	19	7.5.8	To connect the refrigerant piping to the outdoor unit	36
5.4.7	DHW pump for disinfection	19	7.5.9	To connect the refrigerant piping to the indoor unit	36
5.5	Setting up the energy metering	19	7.6	Checking the refrigerant piping	37
5.5.1	Produced heat	19	7.6.1	About checking the refrigerant piping	37
5.5.2	Consumed energy	20	7.6.2	Precautions when checking the refrigerant piping	37
5.5.3	Normal kWh rate power supply	20	7.6.3	To check for leaks	37
5.5.4	Preferential kWh rate power supply	21	7.6.4	To perform vacuum drying	37
5.6	Setting up the power consumption control	21	7.7	Charging refrigerant	38
5.6.1	Permanent power limitation	21	7.7.1	About charging refrigerant	38
5.6.2	Power limitation activated by digital inputs	21	7.7.2	Precautions when charging refrigerant	38
5.6.3	Power limitation process	22	7.7.3	To determine the additional refrigerant amount	38
5.7	Setting up an external temperature sensor	22	7.7.4	To determine the complete recharge amount	38
6	Preparation	23	7.7.5	To charge refrigerant	38
6.1	Overview: Preparation	23	7.7.6	To fix the fluorinated greenhouse gases label	38
6.2	Preparing installation site	23	7.8	Connecting the water piping	39
			7.8.1	About connecting the water piping	39
			7.8.2	Precautions when connecting the water piping	39
			7.8.3	To connect the water piping	39
			7.8.4	To fill the water circuit	39
			7.8.5	To fill the domestic hot water tank	40
			7.8.6	To insulate the water piping	40

7.9	Connecting the electrical wiring.....	40	12 Troubleshooting	78	
7.9.1	About connecting the electrical wiring.....	40	12.1	Overview: Troubleshooting.....	78
7.9.2	About electrical compliance	40	12.2	Precautions when troubleshooting	78
7.9.3	Precautions when connecting the electrical wiring	40	12.3	Solving problems based on symptoms.....	78
7.9.4	Guidelines when connecting the electrical wiring	40	12.3.1	Symptom: The unit is NOT heating or cooling as expected	78
7.9.5	To connect the electrical wiring on the outdoor unit.....	41	12.3.2	Symptom: The compressor does NOT start (space heating or domestic water heating)	78
7.9.6	To connect the electrical wiring on the indoor unit.....	41	12.3.3	Symptom: The pump is making noise (cavitation)	79
7.9.7	To connect the main power supply	42	12.3.4	Symptom: The pressure relief valve opens.....	79
7.9.8	To connect the backup heater power supply	43	12.3.5	Symptom: The water pressure relief valve leaks	79
7.9.9	To connect the user interface	44	12.3.6	Symptom: The space is NOT sufficiently heated at low outdoor temperatures	79
7.9.10	To connect the shut-off valve.....	45	12.3.7	Symptom: The pressure at the tapping point is temporarily unusual high.....	79
7.9.11	To connect the electrical meters	45	12.3.8	Symptom: Decoration panels are pushed away due to a swollen tank	80
7.9.12	To connect the domestic hot water pump	45	12.3.9	Symptom: Tank disinfection function is NOT completed correctly (AH-error).....	80
7.9.13	To connect the alarm output	45	12.4	Solving problems based on error codes.....	80
7.9.14	To connect the space cooling/heating ON/OFF output	46	12.4.1	Error codes: Overview	80
7.9.15	To connect the changeover to external heat source.....	46	13 Disposal	82	
7.9.16	To connect the power consumption digital inputs	46	13.1	Overview: Disposal.....	82
7.10	Finishing the outdoor unit installation	46	13.2	To pump down.....	82
7.10.1	To finish the outdoor unit installation	46	13.3	To start and stop forced cooling	83
7.10.2	To close the outdoor unit	46	14 Technical data	84	
7.11	Finishing the indoor unit installation	46	14.1	Overview: Technical data	84
7.11.1	To fix the user interface cover to the indoor unit.....	46	14.2	Dimensions and service space.....	84
7.11.2	To close the indoor unit.....	47	14.2.1	Dimensions and service space: Outdoor unit	84
			14.2.2	Dimensions and service space: Indoor unit	85
8 Configuration	47		14.3	Center of gravity	87
8.1	Overview: Configuration	47	14.3.1	Center of gravity: Outdoor unit.....	87
8.1.1	To connect the PC cable to the switch box.....	47	14.4	Components	88
8.1.2	To access the most used commands	47	14.4.1	Components: Outdoor unit.....	88
8.1.3	To copy the system settings from the first to the second user interface.....	48	14.4.2	Components: Switch box (outdoor unit).....	88
8.1.4	To copy the language set from the first to the second user interface	48	14.4.3	Components: Indoor unit.....	88
8.1.5	Quick wizard: Set the system layout after first power ON.....	49	14.4.4	Components: Switch box (indoor unit).....	89
8.2	Basic configuration	49	14.5	Piping diagram	90
8.2.1	Quick wizard: Language / time and date.....	49	14.5.1	Piping diagram: Outdoor unit	90
8.2.2	Quick wizard: Standard.....	49	14.5.2	Piping diagram: Indoor unit	91
8.2.3	Quick wizard: Options	51	14.6	Wiring diagram	92
8.2.4	Quick wizard: Capacities (energy metering)	53	14.6.1	Wiring diagram: Outdoor unit	92
8.2.5	Space heating/cooling control.....	53	14.6.2	Wiring diagram: Indoor unit.....	95
8.2.6	Domestic hot water control	56	14.7	Technical specifications	101
8.2.7	Contact/helpdesk number	57	14.7.1	Technical specifications: Outdoor unit	101
8.3	Advanced configuration/optimization.....	57	14.7.2	Technical specifications: Indoor unit.....	104
8.3.1	Space heating/cooling operation: advanced	57	14.8	Operation range	107
8.3.2	Domestic hot water control: advanced.....	60	14.8.1	Operation range: Heating and cooling	107
8.3.3	Heat source settings	64	14.8.2	Operation range: Domestic hot water	108
8.3.4	System settings.....	67	14.8.3	Drain pan necessity	109
8.4	Menu structure: Overview user settings	71	14.9	ESP curve	110
8.5	Menu structure: Overview installer settings.....	72	14.9.1	ESP curve: Indoor unit.....	110
9 Commissioning	73		15 Glossary	111	
9.1	Overview: Commissioning.....	73	16 Field settings table	112	
9.2	Precautions when commissioning	73			
9.3	Checklist before commissioning	73			
9.4	Checklist during commissioning	73			
9.4.1	To check the minimum flow rate	73			
9.4.2	Air purge function.....	74			
9.4.3	To perform a test run	74			
9.4.4	To perform an actuator test run	75			
9.4.5	Underfloor heating screed dryout.....	75			
10 Hand-over to the user	76				
11 Maintenance and service	76				
11.1	Overview: Maintenance and service	76			
11.2	Maintenance safety precautions.....	77			
11.2.1	Opening the indoor unit.....	77			
11.3	Checklist for yearly maintenance of the outdoor unit	77			
11.4	Checklist for yearly maintenance of the indoor unit.....	77			

1 General safety precautions

1 General safety precautions

1.1 About the documentation

- The original documentation is written in English. All other languages are translations.
- The precautions described in this document cover very important topics, follow them carefully.
- The installation of the system, and all activities described in the installation manual and the installer reference guide must be performed by an authorized installer.

1.1.1 Meaning of warnings and symbols



DANGER

Indicates a situation that results in death or serious injury.



DANGER: RISK OF ELECTROCUTION

Indicates a situation that could result in electrocution.



DANGER: RISK OF BURNING

Indicates a situation that could result in burning because of extreme hot or cold temperatures.



WARNING

Indicates a situation that could result in death or serious injury.



CAUTION

Indicates a situation that could result in minor or moderate injury.



NOTICE

Indicates a situation that could result in equipment or property damage.



INFORMATION

Indicates useful tips or additional information.

1.2 For the installer

1.2.1 General

If you are not sure how to install or operate the unit, contact your dealer.



NOTICE

Improper installation or attachment of equipment or accessories could result in electric shock, short-circuit, leaks, fire or other damage to the equipment. Only use accessories, optional equipment and spare parts made or approved by Daikin.



WARNING

Make sure installation, testing and applied materials comply with applicable legislation (on top of the instructions described in the Daikin documentation).



CAUTION

Wear adequate personal protective equipment (protective gloves, safety glasses,...) when installing, maintaining or servicing the system.



WARNING

Tear apart and throw away plastic packaging bags so that nobody, especially children, can play with them. Possible risk: suffocation.



DANGER: RISK OF BURNING

- Do NOT touch the refrigerant piping, water piping or internal parts during and immediately after operation. It could be too hot or too cold. Give it time to return to normal temperature. If you must touch it, wear protective gloves.
- Do NOT touch any accidental leaking refrigerant.



WARNING

Provide adequate measures to prevent that the unit can be used as a shelter by small animals. Small animals that make contact with electrical parts can cause malfunctions, smoke or fire.



CAUTION

Do NOT touch the air inlet or aluminum fins of the unit.



NOTICE

- Do NOT place any objects or equipment on top of the unit.
- Do NOT sit, climb or stand on the unit.



NOTICE

Works executed on the outdoor unit are best done under dry weather conditions to avoid water ingress.

In accordance with the applicable legislation, it might be necessary to provide a logbook with the product containing at least: information on maintenance, repair work, results of tests, stand-by periods,...

Also, at least, following information must be provided at an accessible place at the product:

- Instructions for shutting down the system in case of an emergency
- Name and address of fire department, police and hospital
- Name, address and day and night telephone numbers for obtaining service

In Europe, EN378 provides the necessary guidance for this logbook.

1.2.2 Installation site

- Provide sufficient space around the unit for servicing and air circulation.
- Make sure the installation site withstands the unit's weight and vibration.
- Make sure the area is well ventilated.
- Make sure the unit is level.

Do NOT install the unit in the following places:

- In potentially explosive atmospheres.
- In places where there is machinery that emits electromagnetic waves. Electromagnetic waves may disturb the control system, and cause malfunction of the equipment.
- In places where there is a risk of fire due to the leakage of flammable gases (example: thinner or gasoline), carbon fibre, ignitable dust.
- In places where corrosive gas (example: sulphurous acid gas) is produced. Corrosion of copper pipes or soldered parts may cause the refrigerant to leak.

1.2.3 Refrigerant

If applicable. See the installation manual or installer reference guide of your application for more information.



NOTICE

Make sure refrigerant piping installation complies with applicable legislation. In Europe, EN378 is the applicable standard.



NOTICE

Make sure the field piping and connections are not subjected to stress.



WARNING

During tests, NEVER pressurize the product with a pressure higher than the maximum allowable pressure (as indicated on the nameplate of the unit).



WARNING

Take sufficient precautions in case of refrigerant leakage. If refrigerant gas leaks, ventilate the area immediately. Possible risks:

- Excessive refrigerant concentrations in a closed room can lead to oxygen deficiency.
- Toxic gas may be produced if refrigerant gas comes into contact with fire.



WARNING

Always recover the refrigerant. Do NOT release them directly into the environment. Use a vacuum pump to evacuate the installation.



NOTICE

After all the piping has been connected, make sure there is no gas leak. Use nitrogen to perform a gas leak detection.



NOTICE

- To avoid compressor breakdown, do NOT charge more than the specified amount of refrigerant.
- When the refrigerant system is to be opened, refrigerant must be treated according to the applicable legislation.



WARNING

Make sure there is no oxygen in the system. Refrigerant may only be charged after performing the leak test and the vacuum drying.

- In case re-charge is required, refer to the nameplate of the unit. It states the type of refrigerant and necessary amount.
- The unit is factory charged with refrigerant and depending on pipe sizes and pipe lengths some systems require additional charging of refrigerant.
- Only use tools exclusively for the refrigerant type used in the system, this to ensure pressure resistance and prevent foreign materials from entering into the system.
- Charge the liquid refrigerant as follows:

If	Then
A siphon tube is present (i.e., the cylinder is marked with "Liquid filling siphon attached")	Charge with the cylinder upright. 

If	Then
A siphon tube is NOT present	Charge with the cylinder upside down. 

- Open refrigerant cylinders slowly.
- Charge the refrigerant in liquid form. Adding it in gas form may prevent normal operation.



CAUTION

When the refrigerant charging procedure is done or when pausing, close the valve of the refrigerant tank immediately. If the valve is not closed immediately, remaining pressure might charge additional refrigerant. **Possible consequence:** Incorrect refrigerant amount.

1.2.4 Brine

If applicable. See the installation manual or installer reference guide of your application for more information.



WARNING

The selection of the brine MUST be in accordance with the applicable legislation.



WARNING

Take sufficient precautions in case of brine leakage. If brine leaks, ventilate the area immediately and contact your local dealer.



WARNING

The ambient temperature inside the unit can get much higher than that of the room, e.g. 70°C. In case of a brine leak, hot parts inside the unit can create a hazardous situation.



WARNING

The use and installation of the application MUST comply with the safety and environmental precautions specified in the applicable legislation.

1.2.5 Water

If applicable. See the installation manual or installer reference guide of your application for more information.



NOTICE

Make sure water quality complies with EU directive 98/83 EC.

2 About the documentation

1.2.6 Electrical



DANGER: RISK OF ELECTROCUTION

- Turn OFF all power supply before removing the switch box cover, connecting electrical wiring or touching electrical parts.
- Disconnect the power supply for more than 1 minute, and measure the voltage at the terminals of main circuit capacitors or electrical components before servicing. The voltage MUST be less than 50 V DC before you can touch electrical components. For the location of the terminals, see the wiring diagram.
- Do NOT touch electrical components with wet hands.
- Do NOT leave the unit unattended when the service cover is removed.



WARNING

If NOT factory installed, a main switch or other means for disconnection, having a contact separation in all poles providing full disconnection under overvoltage category III condition, shall be installed in the fixed wiring.



WARNING

- ONLY use copper wires.
- Make sure the field wiring complies with the applicable legislation.
- All field wiring must be performed in accordance with the wiring diagram supplied with the product.
- NEVER squeeze bundled cables and make sure they do not come in contact with the piping and sharp edges. Make sure no external pressure is applied to the terminal connections.
- Make sure to install earth wiring. Do NOT earth the unit to a utility pipe, surge absorber, or telephone earth. Incomplete earth may cause electrical shock.
- Make sure to use a dedicated power circuit. NEVER use a power supply shared by another appliance.
- Make sure to install the required fuses or circuit breakers.
- Make sure to install an earth leakage protector. Failure to do so may cause electric shock or fire.
- When installing the earth leakage protector, make sure it is compatible with the inverter (resistant to high frequency electric noise) to avoid unnecessary opening of the earth leakage protector.

Install power cables at least 1 metre away from televisions or radios to prevent interference. Depending on the radio waves, a distance of 1 metre may not be sufficient.



WARNING

- After finishing the electrical work, confirm that each electrical component and terminal inside the electrical components box is connected securely.
- Make sure all covers are closed before starting up the unit.



NOTICE

Only applicable if the power supply is three-phase, and the compressor has an ON/OFF starting method.

If there exists the possibility of reversed phase after a momentary black out and the power goes on and off while the product is operating, attach a reversed phase protection circuit locally. Running the product in reversed phase can break the compressor and other parts.

2 About the documentation

2.1 About this document

Target audience

Authorised installers

Documentation set

This document is part of a documentation set. The complete set consists of:

Document	Contains...	Format
General safety precautions	Safety instructions that you must read before installing	Paper (in the box of the indoor unit)
Indoor unit installation manual	Installation instructions	
Outdoor unit installation manual	Installation instructions	Paper (in the box of the outdoor unit)
Installer reference guide	Preparation of the installation, technical specifications, good practices, reference data, ...	Digital files on http://www.daikineurope.com/support-and-manuals/product-information/ .
Addendum book for optional equipment	Additional info about how to install optional equipment	Paper (in the box of the indoor unit) Digital files on http://www.daikineurope.com/support-and-manuals/product-information/ .

Latest revisions of the supplied documentation may be available on the regional Daikin website or via your dealer.

The original documentation is written in English. All other languages are translations.

2.2 Installer reference guide at a glance

Chapter	Description
General safety precautions	Safety instructions that you must read before installing
About the documentation	What documentation exists for the installer
About the box	How to unpack the units and remove their accessories
About the units and options	<ul style="list-style-type: none"> How to identify the units Possible combinations of units and options
Application guidelines	Various installation setups of the system
Preparation	What to do and know before going on-site
Installation	What to do and know to install the system
Configuration	What to do and know to configure the system after it is installed
Commissioning	What to do and know to commission the system after it is configured
Hand-over to the user	What to give and explain to the user
Maintenance and service	How to maintain and service the units
Troubleshooting	What to do in case of problems

Chapter	Description
Disposal	How to dispose of the system
Technical data	Specifications of the system
Glossary	Definition of terms
Field settings table	Table to be filled in by the installer, and kept for future reference Note: There is also an installer settings table in the user reference guide. This table has to be filled in by the installer and handed over to the user.

3 About the box

3.1 Overview: About the box

This chapter describes what you have to do after the boxes with the outdoor and indoor unit are delivered on-site.

It contains information about:

- Unpacking and handling the units
- Removing the accessories from the units

Keep the following in mind:

- At delivery, the unit must be checked for damage. Any damage must be reported immediately to the carrier's claims agent.
- Bring the packed unit as close as possible to its final installation position to prevent damage during transport.

3.2 Outdoor unit

3.2.1 To unpack the outdoor unit

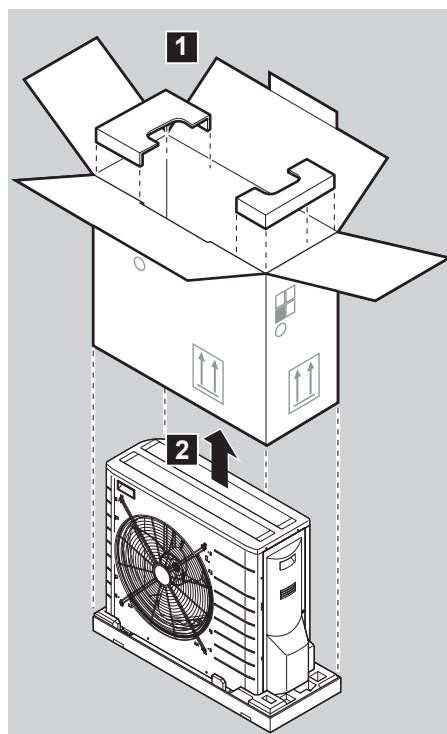
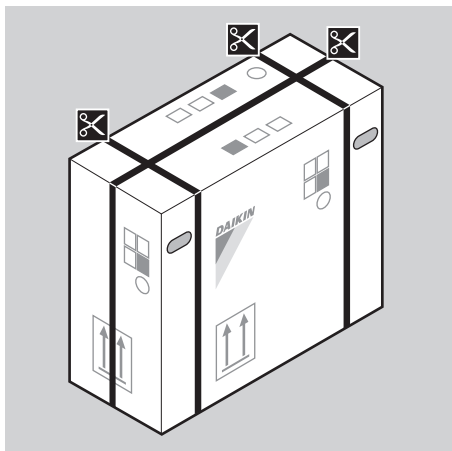

3.2.2 To remove the accessories from the outdoor unit

- 1 Lift the outdoor unit.



CAUTION

Only handle the outdoor unit as follows:

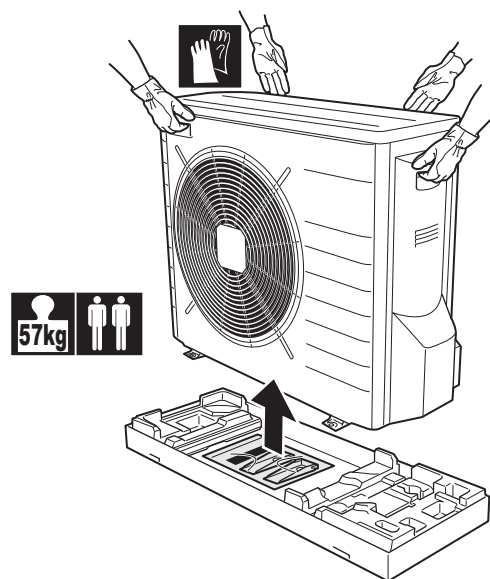

- 2 Remove the accessories at the bottom of the package.

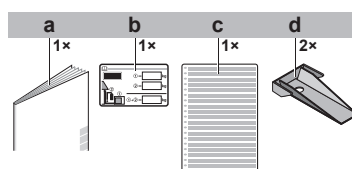

- a Outdoor unit installation manual
- b Fluorinated greenhouse gases label
- c Multilingual fluorinated greenhouse gases label
- d Unit mounting plate

3 About the box

3.3 Indoor unit

3.3.1 To unpack the indoor unit

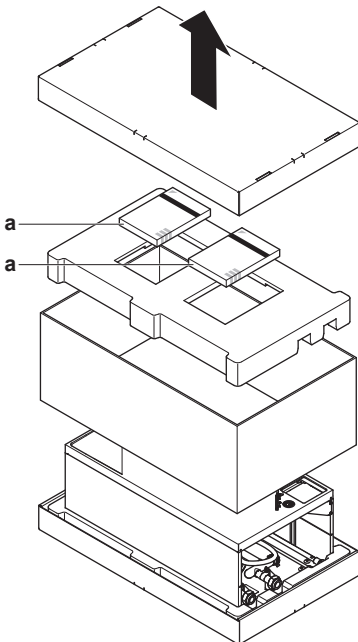
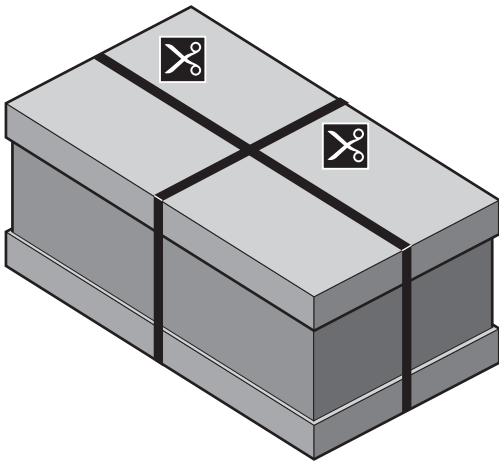

a General safety precautions, indoor unit installation manual, operation manual and addendum book for optional equipment



INFORMATION

Do NOT throw away the upper cardboard cover. On the outside of the cardboard cover, the installation pattern is printed.

3.3.2 To remove the accessories from the indoor unit

The general safety precautions, the indoor unit installation manual, the operation manual and the addendum book for optional equipment are located in the upper part of the box. Follow the procedure below to remove the other accessories.

1 Remove the tape.

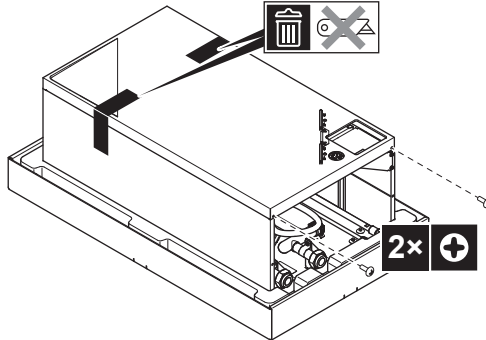

2 Tilt the bottom side of the front panel upwards and remove it.

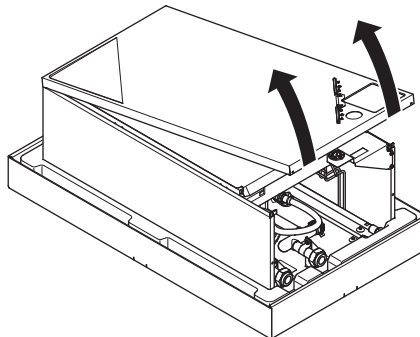

3 Remove the accessories.

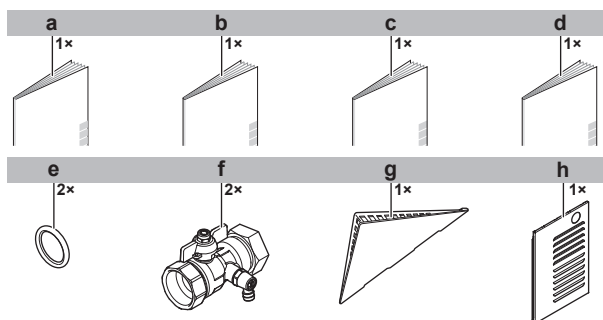
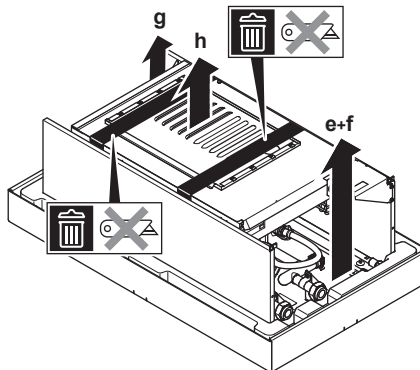

- a General safety precautions
- b Addendum book for optional equipment
- c Indoor unit installation manual
- d Operation manual
- e Sealing ring for shut-off valve
- f Shut-off valve
- g User interface cover
- h Top plate of indoor unit

4 About the units and options

4.1 Overview: About the units and options

This chapter contains information about:

- Identifying the outdoor unit
- Identifying the indoor unit
- Combining outdoor and indoor units
- Combining the outdoor unit with options
- Combining the indoor unit with options

4.2 Identification



NOTICE

When installing or servicing several units at the same time, make sure NOT to switch the service panels between different models.

4.2.1 Identification label: Outdoor unit

Location

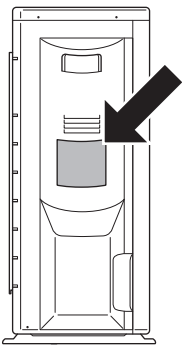

Model identification

Example: ER L Q 006 CA V3

Code	Explanation
ER	European split outdoor pair heat pump
L	Low water temperature – ambient zone: -10~ -20°C
Q	Refrigerant R410A
006	Capacity class
CA	Model series
V3	Power supply

4.2.2 Identification label: Indoor unit

Location

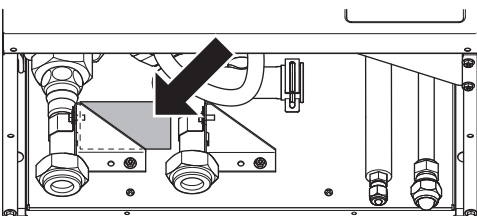

Model identification

Example: E HB H 04 CB 3V

Code	Description
E	European model
HB	Wall-mounted indoor unit
H	H=Heating only X=Heating/cooling
04	Capacity class
CB	Model series
3V	Backup heater model

4.3 Combining units and options

4.3.1 Possible options for the outdoor unit

Drain pan (EKDP008CA)

The drain pan is required to gather the drain from the outdoor unit. The drain pan kit consists of:

- Drain pan
- Installation brackets

For installation instructions, see the installation manual of the drain pan.

Drain pan heater (EKDPH008CA)

The drain pan heater is required to avoid freezing-up of the drain pan.

It is recommended to install this option in colder regions with possible low ambient temperatures or heavy snowfall.

For installation instructions, see the installation manual of the drain pan heater.



INFORMATION

In case the drain pan heater is used, the jumper JP_DP on the service PCB on the outdoor unit MUST be cut.

After cutting the jumper, you MUST reset the outdoor unit to activate this function.

U-beams (EKFT008CA)

The U-beams are installation brackets on which the outdoor unit can be installed.

It is recommended to install this option in colder regions with possible low ambient temperatures or heavy snowfall.

For installation instructions, see the installation manual of the outdoor unit.

4.3.2 Possible options for the indoor unit

User interface (EKRUCL*)

The user interface and a possible additional user interface are available as an option.

The additional user interface can be connected:

- To have both:
 - control close to the indoor unit,
 - room thermostat functionality in the principal space to be heated.
- To have an interface containing other languages.

Following user interfaces are available:

- EKRUCL1 contains following languages: German, French, Dutch, Italian.

4 About the units and options

- EKRUCBL2 contains following languages: English, Swedish, Norwegian, Finnish.
- EKRUCBL3 contains following languages: English, Spanish, Greek, Portuguese.
- EKRUCBL4 contains following languages: English, Turkish, Polish, Romanian.
- EKRUCBL5 contains following languages: German, Czech, Slovenian, Slovakian.
- EKRUCBL6 contains following languages: English, Croatian, Hungarian, Estonian.
- EKRUCBL7 contains following languages: English, German, Russian, Danish.

Languages on the user interface can be uploaded by PC software or copied from an user interface to the other.

For installation instructions, see ["7.9.9 To connect the user interface" on page 44](#).

Simplified user interface (EKRUCBS)

- The simplified user interface can only be used in combination with the main user interface.
- The simplified user interface acts as room thermostat and needs to be installed in the room that you want it to control.

For installation instructions, see the installation and operation manual of the simplified user interface.

Room thermostat (EKRTWA, EKTRT1)

You can connect an optional room thermostat to the indoor unit. This thermostat can either be wired (EKRTWA) or wireless (EKTRT1).

For installation instructions, see the installation manual of the room thermostat and addendum book for optional equipment.

Remote sensor for wireless thermostat (EKRTETS)

You can use a wireless indoor temperature sensor (EKRTETS) only in combination with the wireless thermostat (EKTRT1).

For installation instructions, see the installation manual of the room thermostat and addendum book for optional equipment.

Digital I/O PCB (EKRP1HB)

The digital I/O PCB is required to provide following signals:

- Alarm output
- Space heating/cooling On/OFF output
- Changeover to external heat source
- Only for EHVH/X11+16 models: Control signal for bottom plate heater kit EKBPTH16A.

For installation instructions, see the installation manual of the digital I/O PCB and addendum book for optional equipment.

Demand PCB (EKRP1AHTA)

To enable the power saving consumption control by digital inputs you must install the demand PCB.

For installation instructions, see the installation manual of the demand PCB and addendum book for optional equipment.

Remote indoor sensor (KRCS01-1)

By default the internal user interface sensor will be used as room temperature sensor.

As an option the remote indoor sensor can be installed to measure the room temperature on another location.

For installation instructions, see the installation manual of the remote indoor sensor and addendum book for optional equipment.

INFORMATION

- The remote indoor sensor can only be used in case the user interface is configured with room thermostat functionality.
- You can only connect either the remote indoor sensor or the remote outdoor sensor.

Remote outdoor sensor (EKRS01-1)

By default the sensor inside the outdoor unit will be used to measure the outdoor temperature.

As an option the remote outdoor sensor can be installed to measure the outdoor temperature on another location (e.g. to avoid direct sunlight) to have an improved system behaviour.

For installation instructions, see the installation manual of the remote outdoor sensor.

INFORMATION

You can only connect either the remote indoor sensor or the remote outdoor sensor.

PC configurator (EKPCAB)

The PC cable makes a connection between the switch box of the indoor unit and a PC. It gives the possibility to upload different language files to the user interface and indoor parameters to the indoor unit. For the available language files, contact your local dealer.

The software and corresponding operating instructions are available on <http://www.daikineurope.com/support-and-manuals/software-downloads/>.

For installation instructions, see the installation manual of the PC cable and ["8 Configuration" on page 47](#).

Drain pan kit (EKHBDPCA2)

The drain pan is required to drain accumulated condensation from the indoor unit. It is required during low temperature cooling operation of the indoor unit and when the leaving water temperature is <18°C.

For installation instructions, see the installation manual of the drain pan kit.

Solar kit (EKSOLHW)

The solar kit is required to connect the solar application with the domestic hot water tank.

For installation, see the installation manual of the solar kit and addendum book for optional equipment.

Domestic hot water tank

The domestic hot water tank can be connected to the indoor unit for providing domestic hot water.

4.3.3 Possible combinations of indoor unit and outdoor unit

Indoor unit	Outdoor unit		
	ERLQ004CAV3	ERLQ006CAV3	ERLQ008CAV3
EHBH04CB3V	O	—	—
EHBX04CB3V	O	—	—
EHBH08CB3V	—	O	O
EHBX08CB3V	—	O	O

Indoor unit	Outdoor unit		
	ERLQ004CAV3	ERLQ006CAV3	ERLQ008CAV3
EHBH08CB9W	—	○	○
EHBX08CB9W	—	○	○

4.3.4 Possible combinations of indoor unit and domestic hot water tank

Indoor unit	Domestic hot water tank			
	EKHWS	EKHWSU	EKHWE	EKHWET
EHBH04CB3V	○	○	○	○
EHBX04CB3V	○	○	○	○
EHBH08CB3V	○	○	○	○
EHBX08CB3V	○	○	○	○
EHBH08CB9W	○	○	○	○
EHBX08CB9W	○	○	○	○

5 Application guidelines

5.1 Overview: Application guidelines

The purpose of the application guidelines is to give a glance of the possibilities of the Daikin heat pump system.

NOTICE

- The illustrations in the application guidelines are meant for reference only, and are NOT to be used as detailed hydraulic diagrams. The detailed hydraulic dimensioning and balancing are NOT shown, and are the responsibility of the installer.
- For more information about the configuration settings to optimize heat pump operation, see "8 Configuration" on page 47.

This chapter contains application guidelines for:

- Setting up the space heating/cooling system
- Setting up an auxiliary heat source for space heating
- Setting up the domestic hot water tank
- Setting up the energy metering
- Setting up the power consumption
- Setting up an external temperature sensor

5.2 Setting up the space heating/cooling system

The Daikin heat pump system supplies leaving water to heat emitters in one or more rooms.

Because the system offers a wide flexibility to control the temperature in each room, you need to answer the following questions first:

- How many rooms are heated (or cooled) by the Daikin heat pump system?
- Which heat emitter types are used in each room and what is their design leaving water temperature?

Once the space heating/cooling requirements are clear, Daikin recommends to follow the setup guidelines below.

NOTICE

If an external room thermostat is used, the external room thermostat will control the room frost protection. However, the room frost protection is only possible if the leaving water temperature control on the unit's user interface is turned ON.

INFORMATION

In case an external room thermostat is used and room frost protection needs to be guaranteed in all conditions, then you have to set auto emergency [A.5.1.2] to 1.

5.2.1 Single room

Under floor heating or radiators – Wired room thermostat

Setup

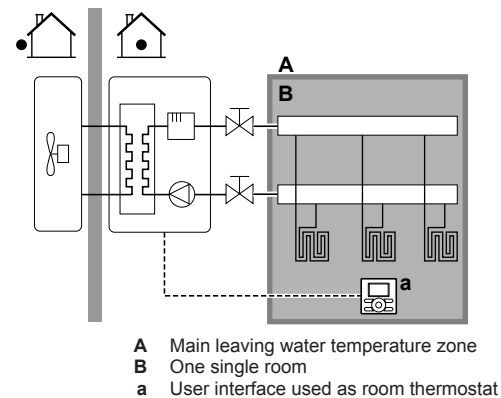

- The under floor heating or radiators are directly connected to the indoor unit.
- The room temperature is controlled by the user interface, which is used as room thermostat. Possible installations:
 - User interface installed in the room and used as room thermostat
 - User interface installed at the indoor unit + user interface installed in the room and used as room thermostat

5 Application guidelines

Configuration

Setting	Value
Unit temperature control: ▪ #: [A.2.1.7] ▪ Code: [C-07]	2 (RT control): Unit operation is decided based on the ambient temperature of the user interface.
Number of water temperature zones: ▪ #: [A.2.1.8] ▪ Code: [7-02]	0 (1 LWT zone): Main

Benefits

- **Cost effective.** You do NOT need an additional external room thermostat.
- **Highest comfort and efficiency.** The smart room thermostat functionality can decrease or increase the desired leaving water temperature based on the actual room temperature (modulation). This results in:
 - Stable room temperature matching the desired temperature (higher comfort)
 - Less ON/OFF cycles (more quiet, higher comfort and higher efficiency)
 - Lowest possible leaving water temperature (higher efficiency)
- **Easy.** You can easily set the desired room temperature via the user interface:
 - For your daily needs, you can use preset values and schedules.
 - To deviate from your daily needs, you can temporarily overrule the preset values and schedules, use the holiday mode...

Under floor heating or radiators – Wireless room thermostat

Setup

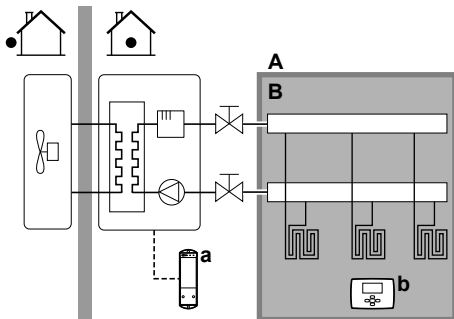

- A Main leaving water temperature zone
- B One single room
- a Receiver for wireless external room thermostat
- b Wireless external room thermostat

- The under floor heating or radiators are directly connected to the indoor unit.
- The room temperature is controlled by the wireless external room thermostat (optional equipment EKTR1).

Configuration

Setting	Value
Unit temperature control: ▪ #: [A.2.1.7] ▪ Code: [C-07]	1 (Ext RT control): Unit operation is decided by the external thermostat.
Number of water temperature zones: ▪ #: [A.2.1.8] ▪ Code: [7-02]	0 (1 LWT zone): Main

Setting	Value
External room thermostat for the main zone: ▪ #: [A.2.2.4] ▪ Code: [C-05]	1 (Thermo ON/OFF): When the used external room thermostat or heat pump convactor can only send a thermo ON/OFF condition.

Benefits

- **Wireless.** The Daikin external room thermostat is available in a wireless version.
- **Efficiency.** Although the external room thermostat only sends ON/OFF signals, it is specifically designed for the heat pump system.
- **Comfort.** In case of under floor heating, the wireless external room thermostat prevents condensation on the floor during cooling operation by measuring the room humidity.

Heat pump convectors

Setup

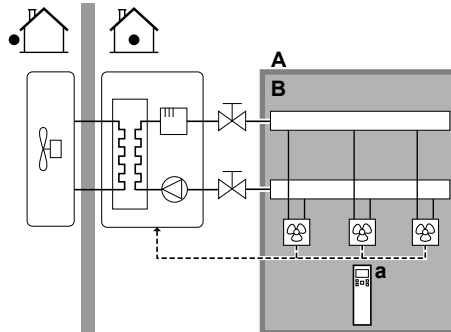

- A Main leaving water temperature zone
- B One single room
- a Remote controller of the heat pump convectors

- The under floor heating or radiators are directly connected to the indoor unit.
- The desired room temperature is set via the remote controller of the heat pump convectors.
- The space heating/cooling demand signal is sent to one digital input on the indoor unit (X2M/1 and X2M/4).
- The space operation mode is sent to the heat pump convectors by one digital output on the indoor unit (X2M/32 and X2M/33).



INFORMATION

When using multiple heat pump convectors, make sure each one receives the infrared signal from the remote controller of the heat pump convectors.

Configuration

Setting	Value
Unit temperature control: ▪ #: [A.2.1.7] ▪ Code: [C-07]	1 (Ext RT control): Unit operation is decided by the external thermostat.
Number of water temperature zones: ▪ #: [A.2.1.8] ▪ Code: [7-02]	0 (1 LWT zone): Main
External room thermostat for the main zone: ▪ #: [A.2.2.4] ▪ Code: [C-05]	1 (Thermo ON/OFF): When the used external room thermostat or heat pump convactor can only send a thermo ON/OFF condition. No separation between heating or cooling demand.

Benefits

- **Cooling.** The heat pump convector offers, besides heating capacity, also excellent cooling capacity.
- **Efficiency.** Optimal energy efficiency because of the interlink function.
- **Stylish.**

Combination: Under floor heating + Heat pump convectors

- Space heating is provided by:
 - The under floor heating
 - The heat pump convectors
- Space cooling is provided by the heat pump convectors only. The under floor heating is shut off by the shut-off valve.

Setup

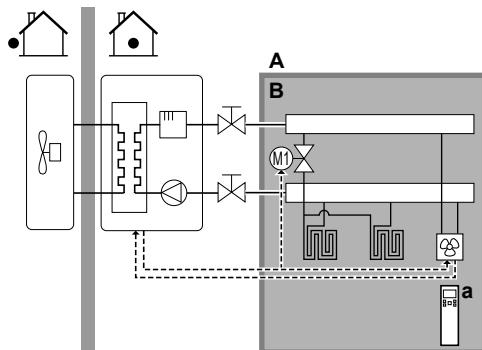

- A** Main leaving water temperature zone
- B** One single room
- a** Remote controller of the heat pump convectors

- The heat pump convectors are directly connected to the indoor unit.
- A shut-off valve (field supply) is installed before the under floor heating to prevent condensation on the floor during cooling operation.
- The desired room temperature is set via the remote controller of the heat pump convectors.
- The space heating/cooling demand signal is sent to one digital input on the indoor unit (X2M/1 and X2M/4)
- The space operation mode is sent by one digital output (X2M/32 and X2M/33) on the indoor unit to:
 - The heat pump convectors
 - The shut-off valve

Configuration

Setting	Value
Unit temperature control: ▪ #: [A.2.1.7] ▪ Code: [C-07]	1 (Ext RT control): Unit operation is decided by the external thermostat.
Number of water temperature zones: ▪ #: [A.2.1.8] ▪ Code: [7-02]	0 (1 LWT zone): Main
External room thermostat for the main zone: ▪ #: [A.2.2.4] ▪ Code: [C-05]	1 (Thermo ON/OFF): When the used external room thermostat or heat pump convector can only send a thermo ON/OFF condition. No separation between heating or cooling demand.

Benefits

- **Cooling.** Heat pump convectors provide, besides heating capacity, also excellent cooling capacity.
- **Efficiency.** Under floor heating has the best performance with Altherma LT.
- **Comfort.** The combination of the two heat emitter types provides:
 - The excellent heating comfort of the under floor heating
 - The excellent cooling comfort of the heat pump convectors

5.2.2 Multiple rooms – One LWT zone

If only one leaving water temperature zone is needed because the design leaving water temperature of all heat emitters is the same, you do NOT need a mixing valve station (cost effective).

Example: If the heat pump system is used to heat up one floor where all the rooms have the same heat emitters.

Under floor heating or radiators – Thermostatic valves

If you are heating up rooms with under floor heating or radiators, a very common way is to control the temperature of the main room by using a thermostat (this can either be the user interface or an external room thermostat), while the other rooms are controlled by so-called thermostatic valves, which open or close depending on the room temperature.

Setup

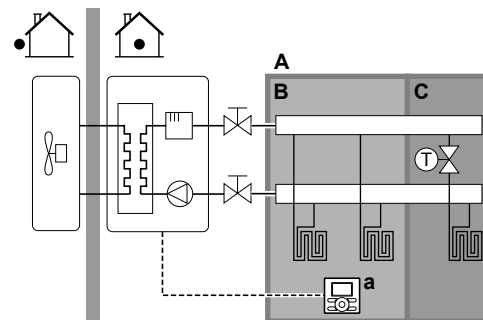

- A** Main leaving water temperature zone
- B** Room 1
- C** Room 2
- a** User interface

- The under floor heating of the main room is directly connected to the indoor unit.
- The room temperature of the main room is controlled by the user interface used as thermostat.
- A thermostatic valve is installed before the under floor heating in each of the other rooms.



INFORMATION

Mind situations where the main room can be heated by another heating source. Example: Fireplaces.

Configuration

Setting	Value
Unit temperature control: ▪ #: [A.2.1.7] ▪ Code: [C-07]	2 (RT control): Unit operation is decided based on the ambient temperature of the user interface.
Number of water temperature zones: ▪ #: [A.2.1.8] ▪ Code: [7-02]	0 (1 LWT zone): Main

5 Application guidelines

Benefits

- **Cost effective.**
- **Easy.** Same installation as for one room, but with thermostatic valves.

Under floor heating or radiators – Multiple external room thermostats

Setup

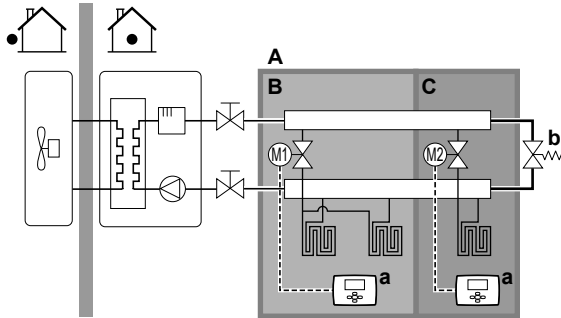

- A Main leaving water temperature zone
- B Room 1
- C Room 2
- a External room thermostat
- b Bypass valve

- For each room, a shut-off valve (field supplied) is installed to avoid leaving water supply when there is no heating or cooling demand.
- A bypass valve must be installed to make water recirculation possible when all shut-off valves are closed. To guarantee reliable operation, provide a minimum water flow as described in table "To check the water volume and flow rate" in "6.4 Preparing water piping" on page 25.
- The user interface connected to the indoor unit decides the space operation mode.
- The room thermostats are connected to the shut-off valves, but do NOT have to be connected to the indoor unit. The indoor unit will supply leaving water all the time, with the possibility to program a leaving water schedule.

Configuration

Setting	Value
Unit temperature control: • #: [A.2.1.7] • Code: [C-07]	0 (LWT control): Unit operation is decided based on the leaving water temperature.
Number of water temperature zones: • #: [A.2.1.8] • Code: [7-02]	0 (1 LWT zone): Main

Benefits

Compared with under floor heating or radiators for one room:

- **Comfort.** You can set the desired room temperature, including schedules, for each room via the room thermostats.

Heat pump convectors

Setup

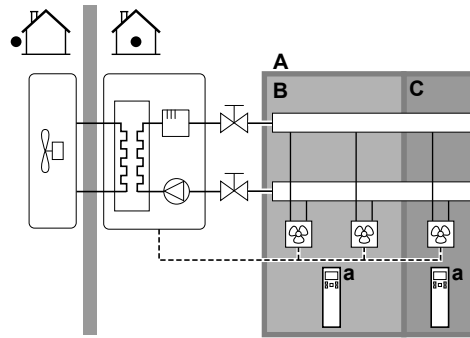

- A Main leaving water temperature zone
- B Room 1
- C Room 2
- a Remote controller of the heat pump convectors

- The desired room temperature is set via the remote controller of the heat pump convectors.
- The user interface connected to the indoor unit decides the space operation mode.
- The heating or cooling demand signals of each heat pump convector are connected in parallel to the digital input on the indoor unit (X2M/1 and X2M/4). The indoor unit will only supply leaving water temperature when there is an actual demand.

i INFORMATION

To increase comfort and performance, Daikin recommends to install the valve kit option EKVKHPC on each heat pump convector.

Configuration

Setting	Value
Unit temperature control: • #: [A.2.1.7] • Code: [C-07]	1 (Ext RT control): Unit operation is decided by the external thermostat.
Number of water temperature zones: • #: [A.2.1.8] • Code: [7-02]	0 (1 LWT zone): Main

Benefits

Compared with heat pump convectors for one room:

- **Comfort.** You can set the desired room temperature, including schedules, for each room via the remote controller of the heat pump convectors.

Combination: Under floor heating + Heat pump convectors

Setup

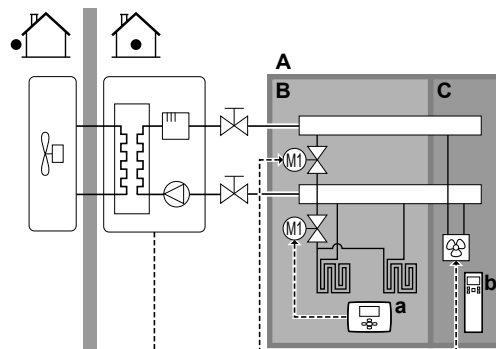

- A** Main leaving water temperature zone
- B** Room 1
- C** Room 2
- a** External room thermostat
- b** Remote controller of the heat pump convectors

- For each room with heat pump convectors: The heat pump convectors are directly connected to the indoor unit.
- For each room with under floor heating: Two shut-off valves (field supply) are installed before the under floor heating:
 - A shut-off valve to prevent hot water supply when the room has no heating demand
 - A shut-off valve to prevent condensation on the floor during cooling operation of the rooms with heat pump convectors.
- For each room with heat pump convectors: The desired room temperature is set via the remote controller of the heat pump convectors.
- For each room with under floor heating: The desired room temperature is set via the external room thermostat (wired or wireless).
- The user interface connected to the indoor unit decides the space operation mode. Mind that the operation mode on each external room thermostat and remote controller of the heat pump convectors must be set to match the indoor unit.

i INFORMATION

To increase comfort and performance, Daikin recommends to install the valve kit option EKVKHPC on each heat pump convector.

Configuration

Setting	Value
Unit temperature control: ▪ #: [A.2.1.7] ▪ Code: [C-07]	0 (LWT control): Unit operation is decided based on the leaving water temperature.
Number of water temperature zones: ▪ #: [A.2.1.8] ▪ Code: [7-02]	0 (1 LWT zone): Main

5.2.3 Multiple rooms – Two LWT zones

If the heat emitters selected for each room are designed for different leaving water temperatures, you can use different leaving water temperature zones (maximum 2).

In this document:

- Main zone = Zone with the lowest design temperature in heating, and the highest design temperature in cooling
- Additional zone = The other zone

! CAUTION

When there is more than one leaving water zone, you must ALWAYS install a mixing valve station in the main zone to decrease (in heating)/increase (in cooling) the leaving water temperature when the additional zone has demand.

Typical example:

Room (zone)	Heat emitters: Design temperature
Living room (main zone)	Under floor heating: ▪ In heating: 35°C ▪ In cooling: 20°C (only refreshment, no real cooling allowed)

Room (zone)	Heat emitters: Design temperature
Bed rooms (additional zone)	Heat pump convectors: ▪ In heating: 45°C ▪ In cooling: 12°C

Setup

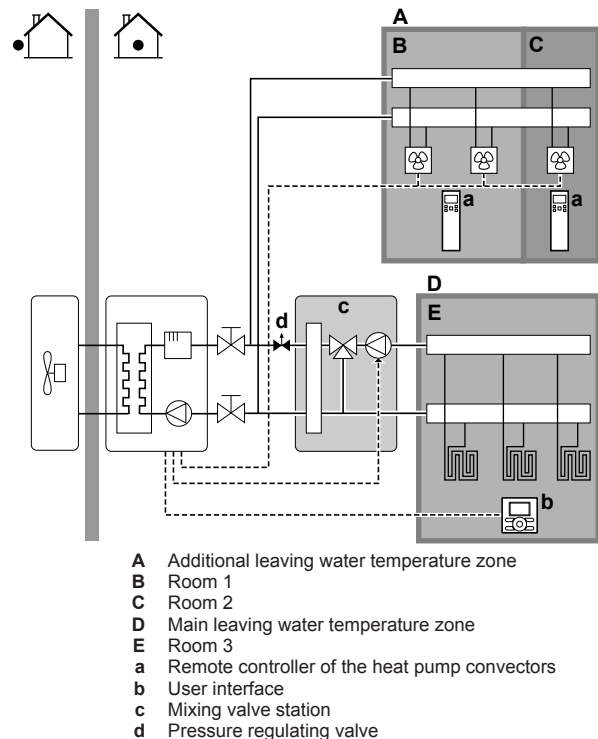

i INFORMATION

A pressure regulating valve should be implemented before the mixing valve station. This is to guarantee the correct water flow balance between the main leaving water temperature zone and the additional leaving water temperature zone in relation to the required capacity of both water temperature zones.

- For the main zone:
 - A mixing valve station is installed before the under floor heating.
 - The pump of the mixing valve station is controlled by the ON/OFF signal on the indoor unit (X2M/5 and X2M/7; normal closed shut-off valve output).
 - The room temperature is controlled by the user interface, which is used as room thermostat.
- For the additional zone:
 - The heat pump convectors are directly connected to the indoor unit.
 - The desired room temperature is set via the remote controller of the heat pump convectors for each room.
 - The heating or cooling demand signals of each heat pump convector are connected in parallel to the digital input on the indoor unit (X2M/1 and X2M/4). The indoor unit will only supply the desired additional leaving water temperature when there is an actual demand.
- The user interface connected to the indoor unit decides the space operation mode. Mind that the operation mode on each remote controller of the heat pump convectors must be set to match the indoor unit.

5 Application guidelines

Configuration

Setting	Value
Unit temperature control: ▪ #: [A.2.1.7] ▪ Code: [C-07]	2 (RT control): Unit operation is decided based on the ambient temperature of the user interface. Note: ▪ Main room = user interface used as room thermostat functionality ▪ Other rooms = external room thermostat functionality
Number of water temperature zones: ▪ #: [A.2.1.8] ▪ Code: [7-02]	1 (2 LWT zones): Main + additional
In case of heat pump convectors: External room thermostat for the additional zone: ▪ #: [A.2.2.5] ▪ Code: [C-06]	1 (Thermo ON/OFF): When the used external room thermostat or heat pump convector can only send a thermo ON/OFF condition. No separation between heating or cooling demand.
Shut-off valve output	Set to follow the thermo demand of the main zone.
Shut-off valve	If the main zone must be shut off during cooling mode to prevent condensation on the floor, set it accordingly.
At the mixing valve station	Set the desired main leaving water temperature for heating and/or cooling.

Benefits

• Comfort.

- The smart room thermostat functionality can decrease or increase the desired leaving water temperature based on the actual room temperature (modulation).
- The combination of the two heat emitter systems provides the excellent heating comfort of the under floor heating, and the excellent cooling comfort of the heat pump convectors.

• Efficiency.

- Depending on the demand, the indoor unit supplies different leaving water temperature matching the design temperature of the different heat emitters.
- Under floor heating has the best performance with Altherma LT.

5.3 Setting up an auxiliary heat source for space heating

- Space heating can be done by:
 - The indoor unit
 - An auxiliary boiler (field supply) connected to the system
- When the room thermostat requests heating, the indoor unit or the auxiliary boiler starts operating depending on the outdoor temperature (status of the changeover to external heat source). When the permission is given to the auxiliary boiler, the space heating by the indoor unit is turned OFF.
- Bivalent operation is only possible for space heating, NOT for domestic hot water production. Domestic hot water is always produced by the DHW tank connected to the indoor unit.

i INFORMATION

- During heating operation of the heat pump, the heat pump operates to achieve the desired temperature set via the user interface. When weather-dependent operation is active, the water temperature is determined automatically depending on the outdoor temperature.
- During heating operation of the auxiliary boiler, the auxiliary boiler operates to achieve the desired water temperature set via the auxiliary boiler controller.

Setup

- Integrate the auxiliary boiler as follows:
Only for EHBH/X

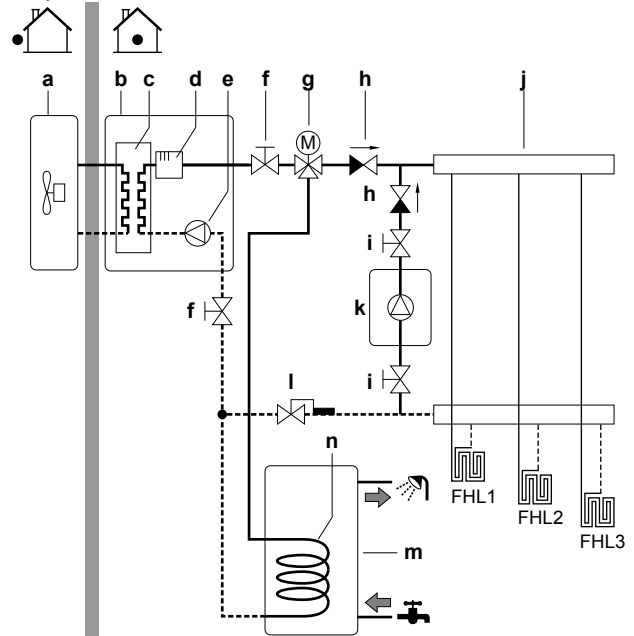

Only for EHVH/X

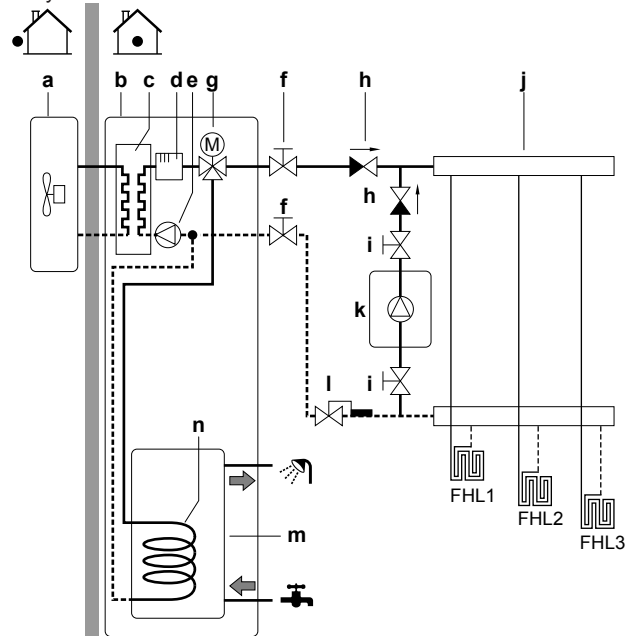

- a Outdoor unit
- b Indoor unit
- c Heat exchanger
- d Backup heater
- e Pump
- f Shut-off valve
- g Motorised 3-way valve (delivered with DHW tank)
- h Non-return valve (field supply)
- i Shut-off valve (field supply)
- j Collector (field supply)

- k** Auxiliary boiler (field supply)
- l** Aquastat valve (field supply)
- m** DHW tank (EHBH/X: option)
- n** Heat exchanger coil
- FHL1...3** Under floor heating

NOTICE

- Make sure the auxiliary boiler and its integration in the system complies with applicable legislation.
- Daikin is NOT responsible for incorrect or unsafe situations in the auxiliary boiler system.

- Make sure the return water to the heat pump does NOT exceed 55°C. To do so:
 - Set the desired water temperature via the auxiliary boiler controller to maximum 55°C.
 - Install an aquastat valve in the return water flow of the heat pump.
 - Set the aquastat valve to close above 55°C and to open below 55°C.
- Install non-return valves.
- Make sure to only have one expansion vessel in the water circuit. An expansion vessel is already premounted in the indoor unit.
- Install the digital I/O PCB (option EKR1HB).
- Connect X1 and X2 (changeover to external heat source) on the PCB to the auxiliary boiler thermostat.
- To setup the heat emitters, see "5.2 Setting up the space heating/cooling system" on page 11.

Configuration

Via the user interface (quick wizard):

- Set the use of a bivalent system as external heat source.
- Set the bivalent temperature and hysteresis.

NOTICE

- Make sure the bivalent hysteresis has enough differential to prevent frequent changeover between indoor unit and auxiliary boiler.
- Because the outdoor temperature is measured by the outdoor unit air thermistor, install the outdoor unit in the shadow so that it is NOT influenced or turned ON/OFF by direct sunlight.
- Frequent changeover may cause corrosion of the auxiliary boiler. Contact the manufacturer of the auxiliary boiler for more information.

Changeover to external heat source decided by an auxiliary contact

- Only possible in external room thermostat control AND one leaving water temperature zone (see "5.2 Setting up the space heating/cooling system" on page 11).
- The auxiliary contact can be:
 - An outdoor temperature thermostat
 - An electricity tariff contact
 - A manually operated contact
 - ...
- Setup: Connect the following field wiring:

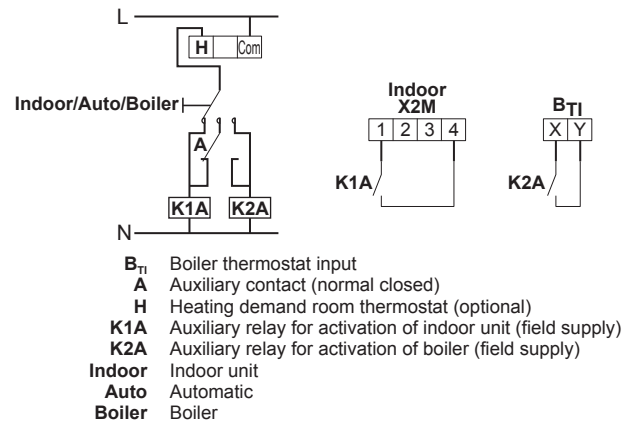

NOTICE

- Make sure the auxiliary contact has enough differential or time delay to prevent frequent changeover between indoor unit and auxiliary boiler.
- If the auxiliary contact is an outdoor temperature thermostat, install the thermostat in the shadow so that it is NOT influenced or turned ON/OFF by direct sunlight.
- Frequent changeover may cause corrosion of the auxiliary boiler. Contact the manufacturer of the auxiliary boiler for more information.

5.4 Setting up the domestic hot water tank

The DHW tank can be:

- Integrated in the indoor unit
- Installed standalone as option

5.4.1 System layout – Integrated DHW tank

Only for EHVH/X.

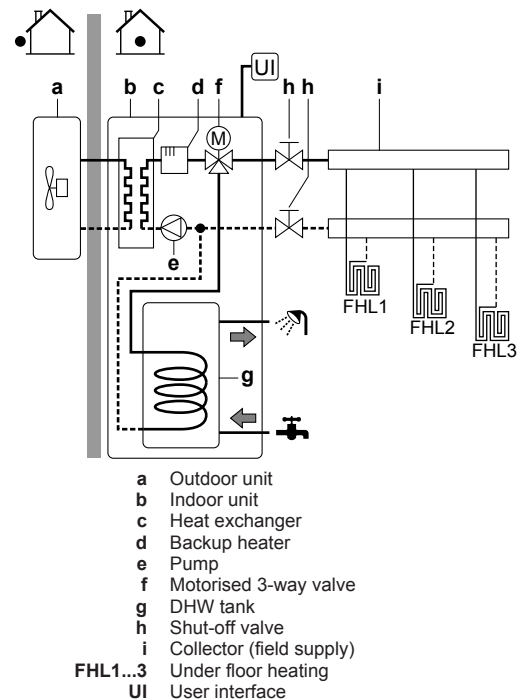

5 Application guidelines

5.4.2 System layout – Standalone DHW tank

Only for EHBH/X.

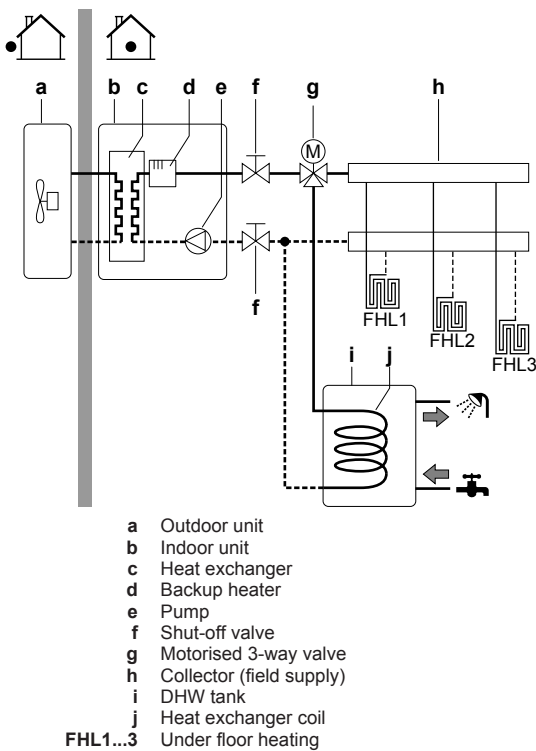

5.4.3 Selecting the volume and desired temperature for the DHW tank

People experience water as hot when its temperature is 40°C. Therefore, the DHW consumption is always expressed as equivalent hot water volume at 40°C. However, you can set the DHW tank temperature at a higher temperature (example: 53°C), which is then mixed with cold water (example: 15°C).

Selecting the volume and desired temperature for the DHW tank consists of:

- 1 Determining the DHW consumption (equivalent hot water volume at 40°C).
- 2 Determining the volume and desired temperature for the DHW tank.

Possible DHW tank volumes

Type	Possible volumes
Integrated DHW tank	<ul style="list-style-type: none"> 180 l 260 l
Standalone DHW tank	<ul style="list-style-type: none"> 150 l 200 l 300 l

Energy saving tips

- If the DHW consumption differs from day to day, you can program a weekly schedule with different desired DHW tank temperatures for each day.
- The lower the desired DHW tank temperature, the more cost effective. By selecting a larger DHW tank, you can lower the desired DHW tank temperature.
- The heat pump itself can produce domestic hot water of maximum 55°C (50°C if outdoor temperature is low). The electrical resistance integrated in the heat pump can higher this temperature. However, this consumes more energy. Daikin recommends to set the desired DHW tank temperature below 55°C to avoid using the electrical resistance.

- The higher the outdoor temperature, the better the performance of the heat pump.
- If energy prices are the same during the day and the night, Daikin recommends to heat up the DHW tank during the day.
- If energy prices are lower during the night, Daikin recommends to heat up the DHW tank during the night.
- When the heat pump produces domestic hot water, it cannot heat up a space. When you need domestic hot water and space heating at the same, Daikin recommends to produce the domestic hot water during the night when there is lower space heating demand.

Determining the DHW consumption

Answer the following questions and calculate the DHW consumption (equivalent hot water volume at 40°C) using the typical water volumes:

Question	Typical water volume
How many showers are needed per day?	1 shower = 10 min×10 l/min = 100 l
How many baths are needed per day?	1 bath = 150 l
How much water is needed at the kitchen sink per day?	1 sink = 2 min×5 l/min = 10 l
Are there any other domestic hot water needs?	—

Example: If the DHW consumption of a family (4 persons) per day is as follows:

- 3 showers
- 1 bath
- 3 sink volumes

Then the DHW consumption = (3×100 l)+(1×150 l)+(3×10 l)=480 l

Determining the volume and desired temperature for the DHW tank

Formula	Example
$V_1 = V_2 + V_2 \times (T_2 - 40) / (40 - T_1)$	If: <ul style="list-style-type: none"> • $V_2 = 180$ l • $T_2 = 54^\circ\text{C}$ • $T_1 = 15^\circ\text{C}$ Then $V_1 = 280$ l
$V_2 = V_1 \times (40 - T_1) / (T_2 - T_1)$	If: <ul style="list-style-type: none"> • $V_1 = 480$ l • $T_2 = 54^\circ\text{C}$ • $T_1 = 15^\circ\text{C}$ Then $V_2 = 307$ l

V_1 DHW consumption (equivalent hot water volume at 40°C)
 V_2 Required DHW tank volume if only heated once
 T_2 DHW tank temperature
 T_1 Cold water temperature

5.4.4 Setup and configuration – DHW tank

- For large DHW consumptions, you can heat up the DHW tank several times during the day.
- To heat up the DHW tank to the desired DHW tank temperature, you can use the following energy sources:
 - Thermodynamic cycle of the heat pump
 - Electrical backup heater (for integrated DHW tank)
 - Electrical booster heater (for standalone DHW tank)
 - Solar panels

- For more information about:
 - Optimizing the energy consumption for producing domestic hot water, see "8 Configuration" on page 47.
 - Connecting the electrical wiring of the standalone DHW tank to the indoor unit, see the installation manual of the DHW tank.
 - Connecting the water piping of the standalone DHW tank to the indoor unit, see the installation manual of the DHW tank.

5.4.5 Combination: Standalone DHW tank + Solar panels

By connecting the DHW tank to solar panels, the DHW tank can be heated by solar energy.

For installation instructions, see the installation manual of the solar kit and addendum book for optional equipment.

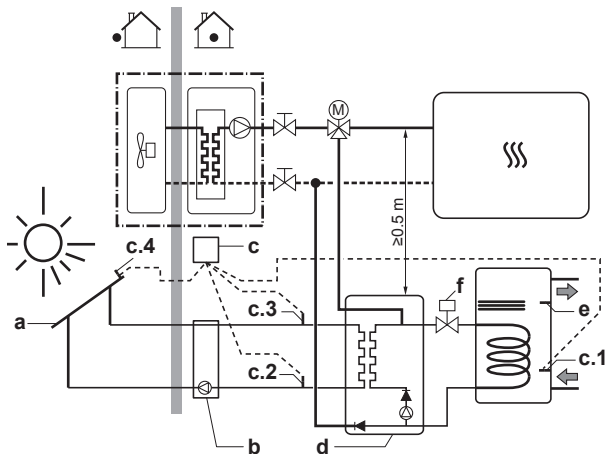

- a Solar panels
- b Solar pump station
- c Solar pump station controller with temperature sensors
- c.1 Tank temperature sensor
- c.2 Return temperature sensor to solar panels
- c.3 Supply temperature with flow meter from solar panels
- c.4 Solar panel temperature sensor
- d Solar kit
- e DHW temperature sensor of the unit
- f Solenoid 2-way valve (only for UK). Obligatory for compliance to UK building regulation G3.

5.4.6 DHW pump for instant hot water

Setup

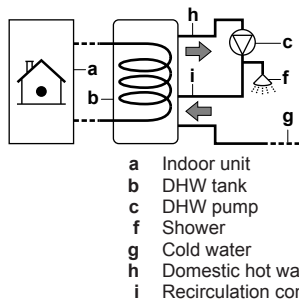

- a Indoor unit
- b DHW tank
- c DHW pump
- f Shower
- g Cold water
- h Domestic hot water OUT
- i Recirculation connection

- By connecting a DHW pump, instant hot water can be available at the tap.
- The DHW pump and the installation are field supply and the responsibility of the installer.
- For more information about connecting the recirculation connection:
 - for integrated DHW tank, see "7 Installation" on page 29,
 - for separate DHW tank, see installation manual of DHW tank.

Configuration

- For more information, see "8 Configuration" on page 47.
- You can program a schedule to control the DHW pump via the user interface. For more information, see the user reference guide.

5.4.7 DHW pump for disinfection

Setup

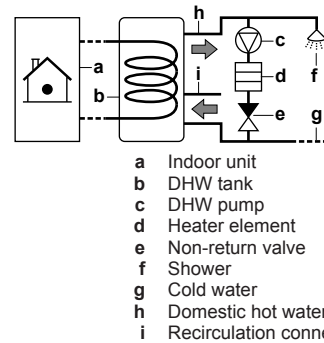

- a Indoor unit
- b DHW tank
- c DHW pump
- d Heater element
- e Non-return valve
- f Shower
- g Cold water
- h Domestic hot water OUT
- i Recirculation connection

- The DHW pump is field-supplied and its installation is the responsibility of the installer.
- For the integrated DHW tank, the temperature of the DHW tank can be set to maximum 60°C. If applicable legislation requires higher temperature for disinfection, you can connect a DHW pump and heater element as shown above.
- If applicable legislation requires disinfection of the water piping until the tapping point, you can connect a DHW pump and heater element (if needed) as shown above.

Configuration

The indoor unit can control DHW pump operation. For more information, see "8 Configuration" on page 47.

5.5 Setting up the energy metering

- Via the user interface, you can read out the following energy data:
 - Produced heat
 - Consumed energy
- You can read out the energy data:
 - For space heating
 - For space cooling
 - For domestic hot water production
- You can read out the energy data:
 - Per month
 - Per year



INFORMATION

The calculated produced heat and consumed energy are an estimation, the accuracy cannot be guaranteed.

5.5.1 Produced heat



INFORMATION

The sensors used to calculate the produced heat are calibrated automatically.

- Applicable for all models.

5 Application guidelines

- The produced heat is calculated internally based on:
 - The leaving and entering water temperature
 - The flow rate
 - The power consumption of the booster heater (if applicable) in the domestic hot water tank
- Setup and configuration:
 - No additional equipment needed.
 - Only in case a booster heater is present in the system, measure its capacity (resistance measurement) and set the capacity via the user interface. **Example:** If you measure a booster heater resistance of 17.1Ω, the capacity of the heater at 230 V is 3100 W.

5.5.2 Consumed energy

You can use the following methods to determine the consumed energy:

- Calculating
- Measuring

i INFORMATION

You cannot combine calculating the consumed energy (example: for backup heater) and measuring the consumed energy (example: for outdoor unit). If you do so, the energy data will be invalid.

Calculating the consumed energy

- Only applicable for EHBH/X04+08 and EHVH/X04+08.
- The consumed energy is calculated internally based on:
 - The actual power input of the outdoor unit
 - The set capacity of the backup heater and booster heater
 - The voltage
- Setup and configuration: To get accurate energy data, measure the capacity (resistance measurement) and set the capacity via the user interface for:
 - The backup heater (step 1 and step 2)
 - The booster heater

Measuring the consumed energy

- Applicable for all models.
- Preferred method because of higher accuracy.
- Requires external power meters.
- Setup and configuration:
 - For the specifications of each type of meter, see ["14 Technical data" on page 84](#).
 - When using electrical power meters, set the number of pulses/kWh for each power meter via the user interface. Consumed energy data for EHVH/X11+16 and EHBH/X11+16 models will only be available if this setting is configured.

i INFORMATION

When measuring the electrical power consumption, make sure ALL power input of the system is covered by the electrical power meters.

5.5.3 Normal kWh rate power supply

General rule

One power meter that covers the entire system is sufficient.

Setup

Connect the power meter to X5M/7 and X5M/8.

Power meter type

In case of...	Use a... power meter
<ul style="list-style-type: none"> Single-phase outdoor unit Backup heater supplied from a single-phase grid (i.e. the backup heater model is *3V or *9W connected to a single-phase grid) 	Single-phase
In other cases (i.e. a three-phase outdoor unit and/or a *9W backup heater model connected to a three-phase grid)	Three-phase

Example

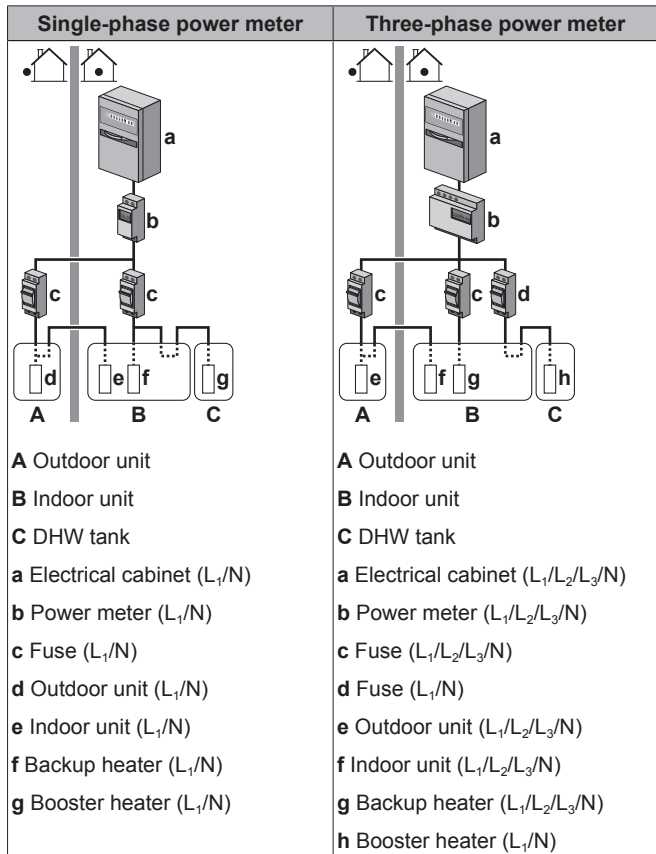

Exception

- You can use a second power meter if:
 - The power range of one meter is insufficient.
 - The electrical meter cannot easily be installed in the electrical cabinet.
 - 230 V and 400 V three-phase grids are combined (very uncommon), because of technical limitations of power meters.
- Connection and setup:
 - Connect the second power meter to X5M/9 and X5M/10.
 - In the software the power consumption data of both meters is added so you do NOT have to set which meter covers which power consumption. You only need to set the number of pulses of each power meter.
- See ["5.5.4 Preferential kWh rate power supply" on page 21](#) for an example with two power meters.

5.5.4 Preferential kWh rate power supply

General rule

- Power meter 1: Measures the outdoor unit.
- Power meter 2: Measures the rest (i.e. indoor unit, backup heater and optional booster heater).

Setup

- Connect power meter 1 to X5M/7 and X5M/8.
- Connect power meter 2 to X5M/9 and X5M/10.

Power meter types

- Power meter 1: Single- or three-phase power meter according to the power supply of the outdoor unit.
- Power meter 2:
 - In case of a single-phase backup heater configuration, use a single-phase power meter.
 - In other cases, use a three-phase power meter.

Example

Single-phase outdoor unit with a three-phase backup heater:

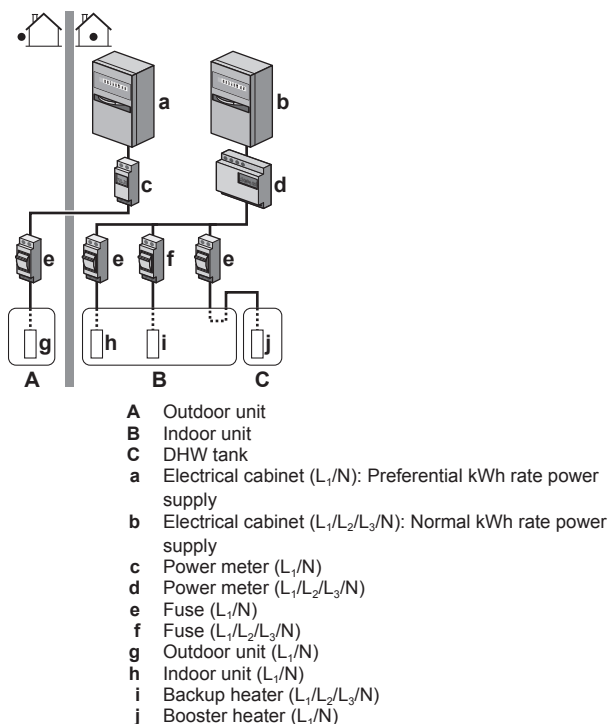

5.6 Setting up the power consumption control

- The power consumption control:
 - Is only applicable for EHBH/X04+08 and EHVH/X04+08.
 - Allows you to limit the power consumption of the entire system (sum of outdoor unit, indoor unit, backup heater and optional booster heater).
 - Configuration: Set the power limitation level and how it has to be achieved via the user interface.
- The power limitation level can be expressed as:
 - Maximum running current (in A)
 - Maximum power input (in kW)
- The power limitation level can be activated:
 - Permanently
 - By digital inputs

5.6.1 Permanent power limitation

Permanent power limitation is useful to assure a maximum power or current input of the system. In some countries, legislation limits the maximum power consumption for space heating and DHW production.

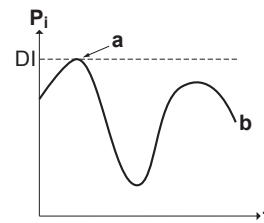

- P_i** Power input
- t** Time
- DI** Digital input (power limitation level)
- a** Power limitation active
- b** Actual power input

Setup and configuration

- No additional equipment needed.
- Set the power consumption control settings in [A.6.3.1] via the user interface (for the description of all settings, see "8 Configuration" on page 47):
 - Select full time limitation mode
 - Select the type of limitation (power in kW or current in A)
 - Set the desired power limitation level



NOTICE

Mind the following guidelines when selecting the desired power limitation level:

- Set a minimum power consumption of ±3.6 kW to guarantee defrost operation. Otherwise, if defrosting is interrupted several times, the heat exchanger will freeze up.
- Set a minimum power consumption of ±3 kW to guarantee space heating and DHW production by allowing at least one electrical heater (backup heater step 1 or booster heater).



NOTICE

Set a minimum power consumption of ±3 kW to guarantee space heating and DHW production by allowing at least backup heater step 1.

5.6.2 Power limitation activated by digital inputs

Power limitation is also useful in combination with an energy management system.

The power or current of the entire Daikin system is limited dynamically by digital inputs (maximum four steps). Each power limitation level is set via the user interface by limiting one of the following:

- Current (in A)
- Power input (in kW)

The energy management system (field supply) decides the activation of a certain power limitation level. **Example:** To limit the maximum power of the entire house (lighting, domestic appliances, space heating...).

5 Application guidelines

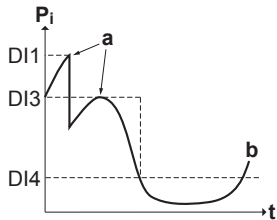
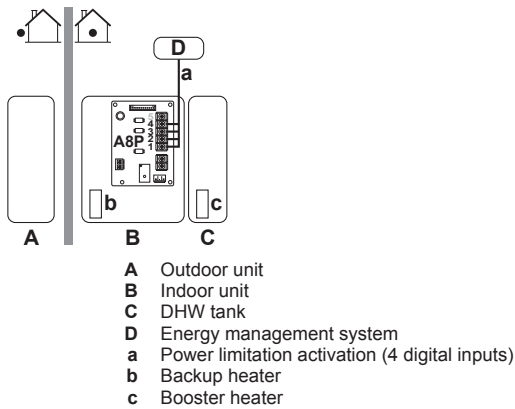

P_i Power input
 t Time
 DI Digital inputs (power limitation levels)
a Power limitation active
b Actual power input

Setup

- Demand PCB (option EKR1AHTA) needed.
- Maximum four digital inputs are used to activate the corresponding power limitation level:
 - DI1 = weakest limitation (highest energy consumption)
 - DI4 = strongest limitation (lowest energy consumption)
- For the specification and the connection of the digital inputs, see "14.6 Wiring diagram – components: Indoor unit" on page 92.

Configuration

Set the power consumption control settings in [A.6.3.1] via the user interface (for the description of all settings, see "8 Configuration" on page 47):

- Select activation by digital inputs.
- Select the type of limitation (power in kW or current in A).
- Set the desired power limitation level corresponding to each digital input.

i INFORMATION

In case more than 1 digital input is closed (at the same time), the digital input priority is fixed: DI4 priority > ... > DI1.

5.6.3 Power limitation process

The outdoor unit has better efficiency than the electrical heaters. Therefore, the electrical heaters are limited and turned OFF first. The system limits power consumption in the following order:

- 1 Limits certain electrical heaters.

If... has priority	Then set the heater priority via the user interface to...
Domestic hot water production	Booster heater. Result: The backup heater will be turned OFF first.
Space heating	Backup heater. Result: The booster heater will be turned OFF first.

- 2 Turns OFF all electrical heaters.
- 3 Limits the outdoor unit.
- 4 Turns OFF the outdoor unit.

Example

If the configuration is as follows:

- Power limitation level does NOT allow operation of both booster heater and backup heater (step 1 and step 2).
- Heater priority = Booster heater.

Then power consumption is limited as follows:

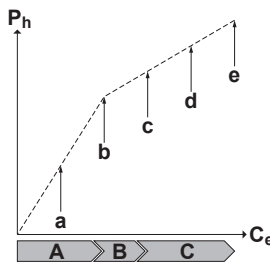

P_h Produced heat
 C_e Consumed energy
A Outdoor unit
B Booster heater
C Backup heater
a Limited outdoor unit operation
b Full outdoor unit operation
c Booster heater turned ON
d Backup heater step 1 turned ON
e Backup heater step 2 turned ON

5.7 Setting up an external temperature sensor

You can connect one external temperature sensor. It can measure the indoor or outdoor ambient temperature. Daikin recommends to use an external temperature sensor in the following cases:

Indoor ambient temperature

- In room thermostat control, the user interface is used as room thermostat and it measures the indoor ambient temperature. Therefore, the user interface must be installed on a location:
 - Where the average temperature in the room can be detected
 - That is NOT exposed to direct sunlight
 - That is NOT near a heat source
 - That is NOT affected by outside air or air draught because of, for example, door opening/closing
- If this is NOT possible, Daikin recommends to connect a remote indoor sensor (option KRCS01-1).
- Setup: For installation instructions, see the installation manual of the remote indoor sensor.

- Configuration: Select room sensor [A.2.2.B].

Outdoor ambient temperature

- In the outdoor unit, the outdoor ambient temperature is measured. Therefore, the outdoor unit must be installed on a location:
 - At the north side of the house or at the side of the house where the most heat emitters are located
 - That is NOT exposed to direct sunlight
- If this is NOT possible, Daikin recommends to connect a remote outdoor sensor (option EKRSCA1).
- Setup: For installation instructions, see the installation manual of the remote outdoor sensor.
- Configuration: Select outdoor sensor [A.2.2.B].
- During suspend (see "8 Configuration" on page 47), the outdoor unit is turned down to reduce the standby energy losses. As a result, the outdoor ambient temperature is NOT read out.
- If the desired leaving water temperature is weather dependent, the full time outdoor temperature measurement is important. This is another reason to install the optional outdoor ambient temperature sensor.

i INFORMATION

The external outdoor ambient sensor data (either averaged or instantaneous) is used in the weather-dependent control curves and in the automatic heating/cooling changeover logic. To protect the outdoor unit, the internal sensor of the outdoor unit is always used.

6 Preparation

6.1 Overview: Preparation

This chapter describes what you have to do and know before going on-site.

It contains information about:

- Preparing the installation site
- Preparing the refrigerant piping
- Preparing the water piping
- Preparing the electrical wiring

6.2 Preparing installation site

Do NOT install the unit in places often used as work place. In case of construction works (e.g. grinding works) where a lot of dust is created, the unit must be covered.

Choose the installation location with sufficient place for carrying the unit in and out of the site.

6.2.1 Installation site requirements of the outdoor unit

i INFORMATION

Also read the following requirements:

- General installation site requirements. See the "General safety precautions" chapter.
- Refrigerant piping requirements (length, height difference). See further in this "Preparation" chapter.

Mind the following spacing guidelines:

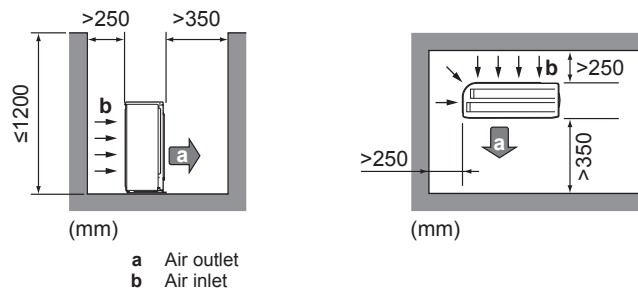

See "14.2 Dimensions and service space" on page 84 for more detailed information about spacing guidelines.

! NOTICE

- Do NOT stack the units on each other.
- Do NOT hang the unit on a ceiling.

Strong winds (≥ 18 km/h) blowing against the outdoor unit's air outlet causes short circuit (suction of discharge air). This may result in:

- deterioration of the operational capacity;
- frequent frost acceleration in heating operation;
- disruption of operation due to decrease of low pressure or increase of high pressure;
- a broken fan (if a strong wind blows continuously on the fan, it may start rotating very fast, until it breaks).

It is recommended to install a baffle plate when the air outlet is exposed to wind.

It is recommended to install the outdoor unit with the air inlet facing the wall and NOT directly exposed to the wind.

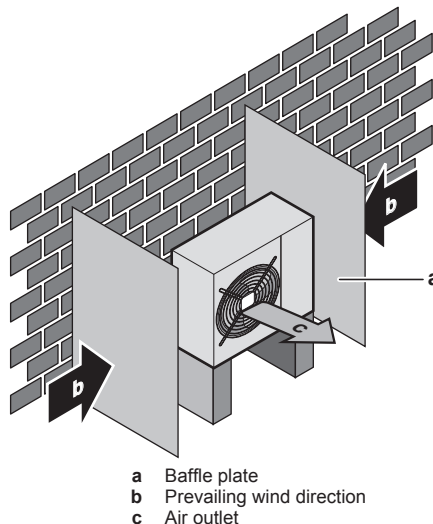

Do NOT install the unit in the following places:

- Sound sensitive areas (e.g. near a bedroom and the like), so that the operation noise will cause no trouble.

Note: If the sound is measured under actual installation conditions, the measured value might be higher than the sound pressure level mentioned in Sound spectrum in the data book due to environmental noise and sound reflections.
- In places where a mineral oil mist, spray or vapour may be present in the atmosphere. Plastic parts may deteriorate and fall off or cause water leakage.

6 Preparation

It is NOT recommended to install the unit in the following places because it may shorten the life of the unit:

- in coastal areas or other places where the air contains high levels of salt. Corrosion may occur,
- where the voltage fluctuates a lot,
- in vehicles or vessels,
- where acidic or alkaline vapour is present.

The outdoor unit is designed for outdoor installation only, and for ambient temperatures ranging 10~43°C in cooling mode and -25~25°C in heating mode.

6.2.2 Additional installation site requirements of the outdoor unit in cold climates

Protect the outdoor unit against direct snowfall and take care that the outdoor unit is NEVER snowed up.

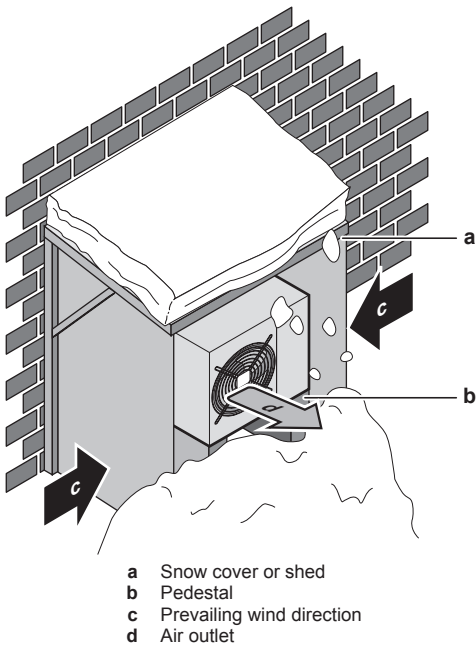

- The unit should be installed in a way that a minimum of 15 cm free space is assured below the bottom plate of the unit at all weather conditions (e.g., heavy snowfall). It is recommended to install the unit at a minimum height of 30 cm. See "7.3 Mounting the outdoor unit" on page 30 for more details.

In heavy snowfall areas it is very important to select an installation site where the snow will NOT affect the unit. If lateral snowfall is possible, make sure that the heat exchanger coil is NOT affected by the snow. If necessary, install a snow cover or shed and a pedestal.

6.2.3 Installation site requirements of the indoor unit

i INFORMATION

Also read the precautions and requirements in the "General safety precautions" chapter.

- Mind the measurement guidelines:

Maximum refrigerant piping length between indoor unit and outdoor unit	30 m
Minimum refrigerant piping length between indoor unit and outdoor unit	3 m
Maximum height difference between indoor unit and outdoor unit	20 m
Maximum distance between the 3-way valve and the indoor unit (for installations with domestic hot water tank)	3 m

Maximum distance between the domestic hot water tank and the indoor unit (for installations with domestic hot water tank)	10 m
---	------

- Mind the following spacing installation guidelines:

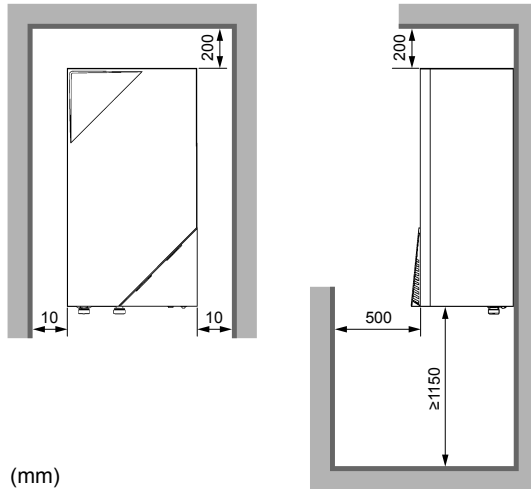

Do NOT install the unit in places such as:

- In places where a mineral oil mist, spray or vapour may be present in the atmosphere. Plastic parts may deteriorate and fall off or cause water leakage.
- Sound sensitive areas (e.g. near a bedroom and the like), so that the operation noise will cause no trouble.
- The foundation must be strong enough to bear the weight of the unit. Take the weight of the unit with a domestic hot water tank full of water into account. Make sure, in the event of a water leak, water cannot cause any damage to the installation space and surroundings.
- In places with high humidity (max. RH=85%), for example a bathroom.
- In places where frost is possible. Ambient temperature around the indoor unit should be >5°C.
- The indoor unit is designed for indoor installation only and for ambient temperatures ranging from 5~35°C.

6.3 Preparing refrigerant piping

6.3.1 Refrigerant piping requirements

i INFORMATION

Also read the precautions and requirements in the "General safety precautions" chapter.

- **Piping material:** Phosphoric acid deoxidised seamless copper.
- **Piping diameter:**

Liquid piping	Ø6.4 mm (1/4")
Gas piping	Ø15.9 mm (5/8")

- **Piping temper grade and thickness:**

Outer diameter (Ø)	Temper grade	Thickness (t) ^(a)	
6.4 mm (1/4")	Annealed (O)	≥0.8 mm	
15.9 mm (5/8")	Annealed (O)	≥1.0 mm	

(a) Depending on the applicable legislation and the unit's maximum working pressure (see "PS High" on the unit name plate), larger piping thickness might be required.

6.3.2 Refrigerant piping insulation

- Use polyethylene foam as insulation material:
 - with a heat transfer rate between 0.041 and 0.052 W/mK (0.035 and 0.045 kcal/mh°C)
 - with a heat resistance of at least 120°C
- Insulation thickness

Pipe outer diameter (\varnothing_p)	Insulation inner diameter (\varnothing_i)	Insulation thickness (t)
6.4 mm (1/4")	8~10 mm	10 mm
15.9 mm (5/8")	16~20 mm	13 mm



If the temperature is higher than 30°C and the humidity is higher than RH 80%, the thickness of the insulation materials should be at least 20 mm to prevent condensation on the surface of the insulation.

6.4 Preparing water piping

6.4.1 Water circuit requirements

i INFORMATION

Also read the precautions and requirements in the "General safety precautions" chapter.

- Connecting piping – Legislation.** Make all piping connections in accordance with the applicable legislation and the instructions in the "Installation" chapter, respecting the water inlet and outlet.
- Connecting piping – Force.** Do NOT use excessive force when connecting the piping. Deformation of the piping can cause malfunctioning of the unit.
- Connecting piping – Tools.** Only use appropriate tooling to handle brass, which is a soft material. If NOT, pipes will get damaged.
- Connecting piping – Air, moisture, dust.** If air, moisture or dust gets into the circuit, problems may occur. To prevent this:
 - Only use clean pipes
 - Hold the pipe end downwards when removing burrs.
 - Cover the pipe end when inserting it through a wall, to prevent dust and/or particles entering the pipe.
 - Use a decent thread sealant to seal connections.
- Closed circuit.** Use the indoor unit ONLY in a closed water system. Using the system in an open water system will lead to excessive corrosion.
- Glycol.** For safety reasons, it is NOT allowed to add any kind of glycol to the water circuit.
- Piping length.** It is recommended to avoid long runs of piping between the domestic hot water tank and the hot water end point (shower, bath,...) and to avoid dead ends.
- Piping diameter.** Select the water piping diameter in relation to the required water flow and the available external static pressure of the pump. See "14 Technical data" on page 84 for the external static pressure curves of the indoor unit.
- Water flow.** You can find the minimum required water flow for indoor unit operation in the following table. In all cases, this flow needs to be guaranteed. When the flow is lower, the indoor unit will stop operation and display error 7H.

Minimum required flow rate during defrost/backup heater operation

04+08 models	12 l/min
11+16 models	15 l/min

- Field supply components – Water.** Only use materials that are compatible with water used in the system and with the materials used in the indoor unit.
- Field supply components – Water pressure and temperature.** Check that all components in the field piping can withstand the water pressure and water temperature.
- Water pressure.** The maximum water pressure is 4 bar. Provide adequate safeguards in the water circuit to ensure that the maximum pressure is NOT exceeded.
- Water temperature.** All installed piping and piping accessories (valve, connections,...) MUST withstand the following temperatures:

i INFORMATION

The following illustration is an example and might NOT match your system layout.

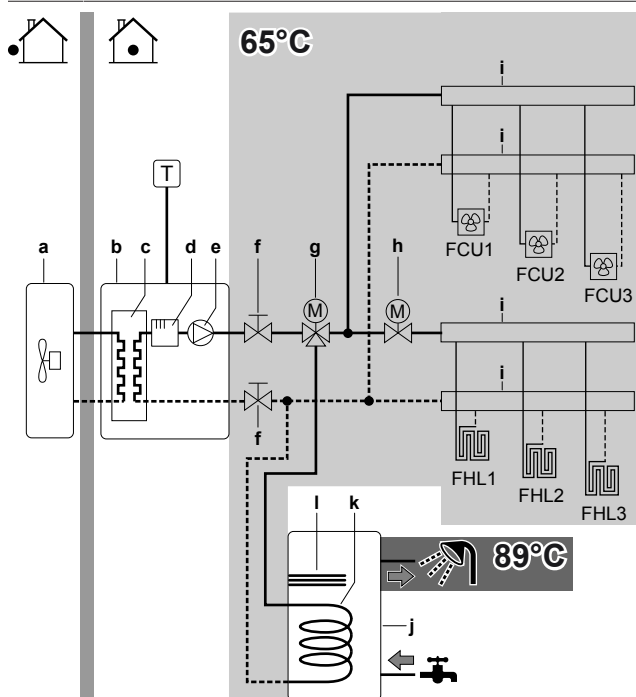

- a Outdoor unit
- b Indoor unit
- c Heat exchanger
- d Backup heater
- e Pump
- f Shut-off valve
- g Motorised 3-way valve (supplied with the domestic hot water tank)
- h Motorised 2-way valve (field supply)
- i Collector
- j Domestic hot water tank
- k Heat exchanger coil
- l Booster heater
- FCU1...3 Fan coil unit (optional)
- FHL1...3 Floor heating loop
- T Room thermostat (optional)

- Drainage – Low points.** Provide drain taps at all low points of the system in order to allow complete drainage of the water circuit.
- Drainage – Pressure relief valve.** Provide a proper drain for the pressure relief valve to avoid water coming into contact with electrical parts.

6 Preparation

- **Air vents.** Provide air vents at all high points of the system, which must also be easily accessible for servicing. An automatic air purge is provided in the indoor unit. Check that the air purge is NOT tightened too much, so that automatic release of air in the water circuit is possible.
- **Zn-coated parts.** Never use Zn-coated parts in the water circuit. Because the unit's internal water circuit uses copper piping, excessive corrosion may occur.
- **Non-brass metallic piping.** When using non-brass metallic piping, insulate the brass and non-brass properly so that they do NOT make contact with each other. This to prevent galvanic corrosion.
- **Valve – Separating circuits.** When using a 3-way valve in the water circuit make sure that the domestic hot water circuit and the floor heating circuit is fully separated.
- **Valve – Change-over time.** When using a 2-way valve or a 3-way valve in the water circuit, the maximum change-over time of the valve must be 60 seconds.
- **Filter.** It is strongly recommended to install an additional filter on the heating water circuit. Especially to remove metallic particles from foul heating piping, it is recommended to use a magnetic or cyclone filter, which can remove small particles. Small particles may damage the unit and will NOT be removed by the standard filter of the heat pump system.
- **Domestic hot water tank – Capacity.** To avoid stagnation of water, it is important that the storage capacity of the domestic hot water tank meets the daily consumption of domestic hot water.
- **Domestic hot water tank – After installation.** Immediately after installation, the domestic hot water tank must be flushed with fresh water. This procedure must be repeated at least once a day the first 5 consecutive days after installation.
- **Domestic hot water tank – Standstills.** In cases where during longer periods of time there is no consumption of hot water, the equipment MUST be flushed with fresh water before usage.
- **Domestic hot water tank – Disinfection.** For the disinfection function of the domestic hot water tank, see "8.3.2 Domestic hot water control: advanced" on page 60.
- **Thermostatic mixing valves.** In accordance with the applicable legislation, it may be necessary to install thermostatic mixing valves.
- **Hygienic measures.** The installation must be in compliance with the applicable legislation and may require additional hygienic installation measures.
- **Recirculation pump.** In accordance with the applicable legislation, it may be required to connect a recirculation pump in between the hot water end point and the recirculation connection of the domestic hot water tank.

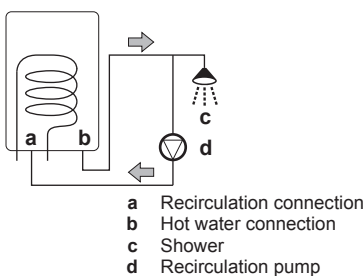

6.4.2 Formula to calculate the expansion vessel pre-pressure

The pre-pressure (P_g) of the vessel depends on the installation height difference (H):

$$P_g = 0.3 + (H/10) \text{ (bar)}$$

6.4.3 To check the water volume and flow rate

The indoor unit has an expansion vessel of 10 litre with a factory-set pre-pressure of 1 bar.

To make sure that the unit operates properly:

- You must check the minimum and maximum water volume.
- You might need to adjust the pre-pressure of the expansion vessel.

Minimum water volume

Check that the total water volume in the installation is minimum 10 litre, the internal water volume of the indoor unit NOT included.

INFORMATION

In critical processes, or in rooms with a high heat load, extra water might be required.

NOTICE

When circulation in each space heating loop is controlled by remotely controlled valves, it is important that the minimum water volume is guaranteed, even if all of the valves are closed.

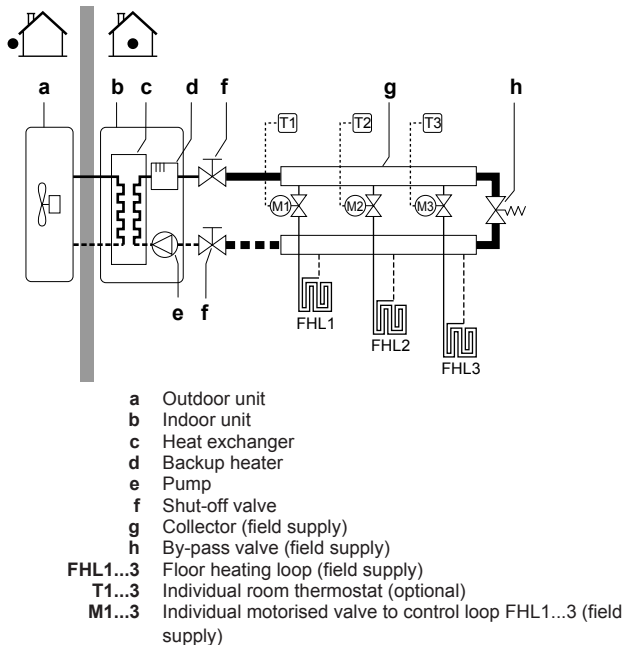

Maximum water volume

Use the following graph to determine the maximum water volume for the calculated pre-pressure.

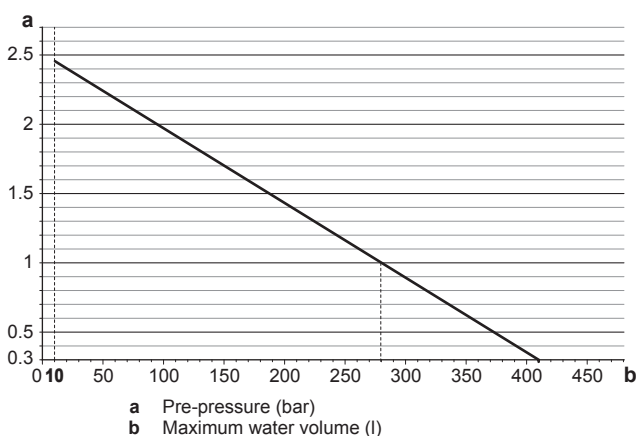

Example: Maximum water volume and expansion vessel pre-pressure

Installation height difference ^(a)	Water volume	
	≤280 l	>280 l
≤7 m	No pre-pressure adjustment is required.	Do the following: <ul style="list-style-type: none"> Decrease the pre-pressure. Check if the water volume does NOT exceed the maximum allowed water volume.
>7 m	Do the following: <ul style="list-style-type: none"> Increase the pre-pressure. Check if the water volume does NOT exceed the maximum allowed water volume. 	The expansion vessel of the indoor unit is too small for the installation. In this case, it is recommended to install an extra vessel outside the unit.

(a) This is the height difference (m) between the highest point of the water circuit and the indoor unit. If the indoor unit is at the highest point of the installation, the installation height is 0 m.

Minimum flow rate

Check that the minimum flow rate (required during defrost/backup heater operation) in the installation is guaranteed in all conditions.

NOTICE

When circulation in each or certain space heating loops is controlled by remotely controlled valves, it is important that the minimum flow rate is guaranteed, even if all valves are closed. In case the minimum flow rate cannot be reached, a flow error 7H will be generated (no heating/operation).

Minimum required flow rate during defrost/backup heater operation

04+08 models	12 l/min
11+16 models	15 l/min

See the recommended procedure as described in "9.4 Checklist during commissioning" on page 73.

6.4.4 Changing the pre-pressure of the expansion vessel**NOTICE**

Only a licensed installer may adjust the pre-pressure of the expansion vessel.

When changing the default pre-pressure of the expansion vessel (1 bar) is required, take following guidelines into account:

- Only use dry nitrogen to set the expansion vessel pre-pressure.
- Inappropriate setting of the expansion vessel pre-pressure will lead to malfunction of the system.

Changing the pre-pressure of the expansion vessel should be done by releasing or increasing nitrogen pressure through the schröder valve of the expansion vessel.

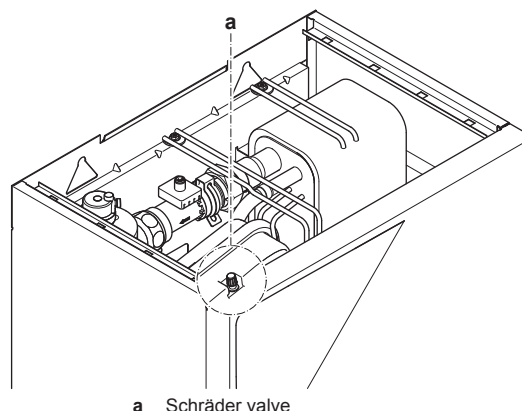

a Schröder valve

6.4.5 To check the water volume: Examples**Example 1**

The indoor unit is installed 5 m below the highest point in the water circuit. The total water volume in the water circuit is 100 l.

No actions or adjustments are required.

Example 2

The indoor unit is installed at the highest point in the water circuit. The total water volume in the water circuit is 350 l.

Actions:

- Because the total water volume (350 l) is more than the default water volume (280 l), the pre-pressure must be decreased.
- The required pre-pressure is:
 $P_g = (0.3 + (H/10)) \text{ bar} = (0.3 + (0/10)) \text{ bar} = 0.3 \text{ bar}$.
- The corresponding maximum water volume at 0.3 bar is 410 l. (See the graph in the chapter above).
- Because 350 l is lower than 410 l, the expansion vessel is appropriate for the installation.

6.5 Preparing electrical wiring**6.5.1 About preparing electrical wiring****INFORMATION**

Also read the precautions and requirements in the "General safety precautions" chapter.

**WARNING**

- If the power supply has a missing or wrong N-phase, equipment might break down.
- Establish proper earthing. Do NOT earth the unit to a utility pipe, surge absorber, or telephone earth. Incomplete earthing may cause electrical shock.
- Install the required fuses or circuit breakers.
- Secure the electrical wiring with cable ties so that the cables do NOT come in contact with sharp edges or piping, particularly on the high-pressure side.
- Do NOT use taped wires, stranded conductor wires, extension cords, or connections from a star system. They can cause overheating, electrical shock or fire.
- Do NOT install a phase advancing capacitor, because this unit is equipped with an inverter. A phase advancing capacitor will reduce performance and may cause accidents.

6 Preparation

WARNING

- All wiring must be performed by an authorized electrician and must comply with the applicable legislation.
- Make electrical connections to the fixed wiring.
- All components procured on the site and all electrical construction must comply with the applicable legislation.

WARNING

The backup heater should have a dedicated power supply.

WARNING

ALWAYS use multicore cable for power supply cables.

6.5.2 About preferential kWh rate power supply

Electricity companies throughout the world work hard to provide reliable electric service at competitive prices and are often authorized to bill clients at benefit rates. E.g. time-of-use rates, seasonal rates, Wärmepumpentarif in Germany and Austria, ...

This equipment allows for connection to such preferential kWh rate power supply delivery systems.

Consult with the electricity company acting as provider at the site where this equipment is to be installed to know whether it is appropriate to connect the equipment in one of the preferential kWh rate power supply delivery systems available, if any.

When the equipment is connected to such preferential kWh rate power supply, the electricity company is allowed to:

- interrupt power supply to the equipment for certain periods of time;
- demand that the equipment only consumes a limited amount of electricity during certain periods of time.

The indoor unit is designed to receive an input signal by which the unit switches into forced off mode. At that moment, the outdoor unit compressor will not operate.

Whether the power supply is interrupted or not, the wiring to the unit is different.

Overview of electrical connections except external actuators

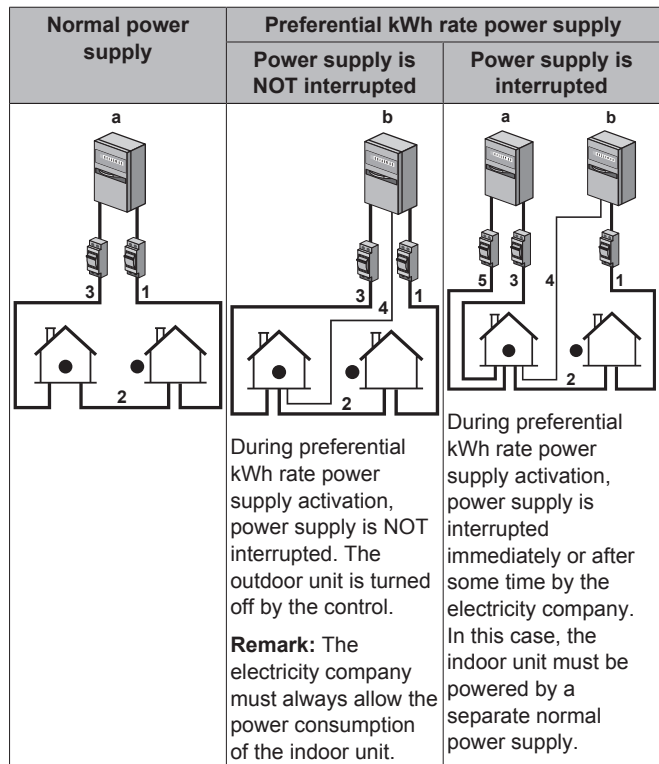

- a Normal power supply
- b Preferential kWh rate power supply
- 1 Power supply for outdoor unit
- 2 Power supply and interconnection cable to indoor unit
- 3 Power supply for backup heater
- 4 Preferential kWh rate power supply (voltage free contact)
- 5 Normal kWh rate power supply (to power the indoor unit PCB in the event of power supply interruption of the preferential kWh rate power supply)

6.5.3 Overview of electrical connections for external and internal actuators

The following illustration shows the required field wiring.

INFORMATION

The following illustration is an example and might NOT match your system layout.

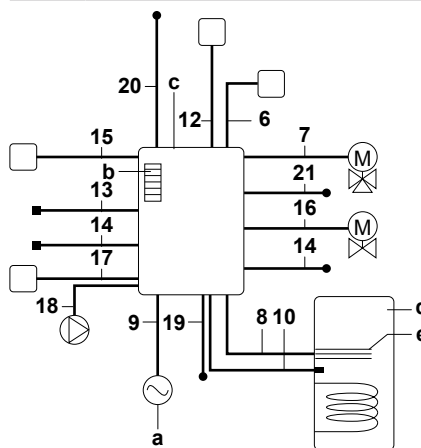

- a Single power supply for outdoor unit, backup heater and booster heater
- b Backup heater
- c Indoor unit
- d Domestic hot water tank
- e Booster heater

Item	Description	Wires	Maximum running current
Outdoor unit and indoor unit power supply			
1	Power supply for outdoor unit	2+GND or 3+GND	(a)
2	Power supply and interconnection cable to indoor unit	3	(c)
3	Power supply for backup heater	See table below.	—
4	Preferential kWh rate power supply (voltage free contact)	2	(e)
5	Normal kWh rate power supply	2	6.3 A
User interface			
6	User interface	2	(f)
Optional equipment			
7	3-way valve	3	100 mA ^(b)
8	Power supply for booster heater and thermal protection (from indoor unit)	4+GND	(c)
9	Power supply for booster heater (to indoor unit)	2+GND	13 A
10	Domestic hot water tank thermistor	2	(d)
11	Power supply for bottom plate heater	2	(b)
12	Room thermostat	3 or 4	100 mA ^(b)
13	Outdoor ambient temperature sensor	2	(b)
14	Indoor ambient temperature sensor	2	(b)
15	Heat pump convector	4	100 mA ^(b)
Field supplied components			
16	Shut-off valve	2	100 mA ^(b)
17	Electricity meter	2 (per meter)	(b)
18	Domestic hot water pump	2	(b)
19	Alarm output	2	(b)
20	Changeover to external heat source control	2	(b)
21	Space cool/heat operation control	2	(b)
22	Power consumption digital inputs	2 (per input signal)	(b)

- (a) Refer to name plate on outdoor unit.
 (b) Minimum cable section 0.75 mm².
 (c) Cable section 2.5 mm².
 (d) The thermistor and connection wire (12 m) are delivered with the domestic hot water tank.
 (e) Cable section 0.75 mm² till 1.25 mm²; maximum length: 50 m. Voltage-free contact shall ensure the minimum applicable load of 15 V DC, 10 mA.
 (f) Cable section 0.75 mm² till 1.25 mm²; maximum length: 500 m. Applicable for both single user interface and dual use interface connection.

**NOTICE**

More technical specifications of the different connections are indicated on the inside of the indoor unit.

Backup heater type	Power supply	Required number of conductors
*3V	1× 230 V	2+GND
*9W	1× 230 V	2+GND + 2 bridges
	3× 230 V	3+GND + 1 bridge
	3× 400 V	4+GND

7 Installation

7.1 Overview: Installation

This chapter describes what you have to do and know on-site to install the system.

Typical workflow

Installation typically consists of the following stages:

- 1 Mounting the outdoor unit.
- 2 Mounting the indoor unit.
- 3 Connecting the refrigerant piping.
- 4 Checking the refrigerant piping.
- 5 Charging refrigerant.
- 6 Connecting the water piping.
- 7 Connecting the electrical wiring.
- 8 Finishing the outdoor installation.
- 9 Finishing the indoor installation.

**INFORMATION**

Depending on the units and/or the installation conditions, it might be necessary to connect electrical wiring before you can charge refrigerant.

7.2 Opening the units

7.2.1 About opening the units

At certain times, you have to open the unit. **Example:**

- When connecting the refrigerant piping
- When connecting the electrical wiring
- When maintaining or servicing the unit

**DANGER: RISK OF ELECTROCUTION**

Do NOT leave the unit unattended when the service cover is removed.

7.2.2 To open the outdoor unit

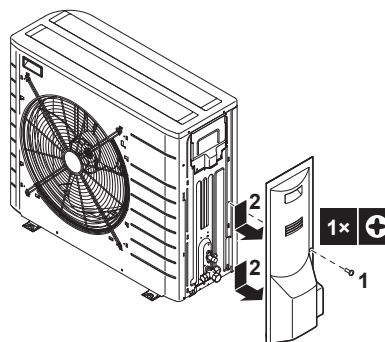
**DANGER: RISK OF ELECTROCUTION****DANGER: RISK OF BURNING**

7 Installation

7.2.3 To open the indoor unit

- 1 Loosen and remove the 2 screws that fix the front panel.

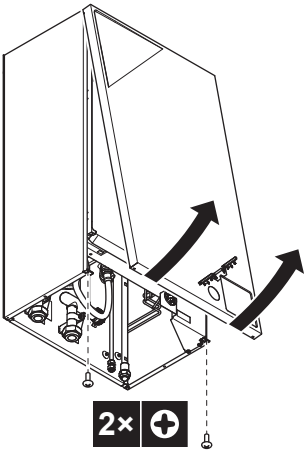

- 2 Tilt the front panel towards you and remove the front panel.

7.2.4 To open the switch box cover of the indoor unit

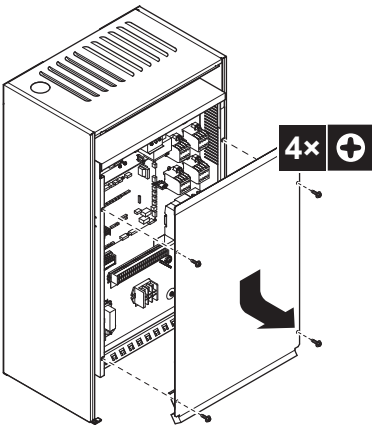

7.3 Mounting the outdoor unit

7.3.1 About mounting the outdoor unit

When

You have to mount the outdoor and indoor unit before you can connect the refrigerant and water piping.

Typical workflow

Mounting the outdoor unit typically consists of the following stages:

- 1 Providing the installation structure.
- 2 Installing the outdoor unit.
- 3 Providing drainage.
- 4 Preventing the outdoor unit from falling over.
- 5 Protecting the unit against snow and wind by installing a snow cover and baffle plates. See "Preparing installation site" in ["6 Preparation" on page 23](#).

7.3.2 Precautions when mounting the outdoor unit



INFORMATION

Also read the precautions and requirements in the following chapters:

- General safety precautions
- Preparation

7.3.3 To provide the installation structure

Check the strength and level of the installation ground so that the unit will not cause any operating vibration or noise.

Fix the unit securely by means of foundation bolts in accordance with the foundation drawing.

If the unit is installed directly on the floor, prepare 4 sets of M8 or M10 anchor bolts, nuts and washers (field supply) as follows:



INFORMATION

The maximum height of the upper protruding part of the bolts is 15 mm.



NOTICE

Fix the outdoor unit to the foundation bolts using nuts with resin washers (a). If the coating on the fastening area is stripped off, the nuts rust easily.

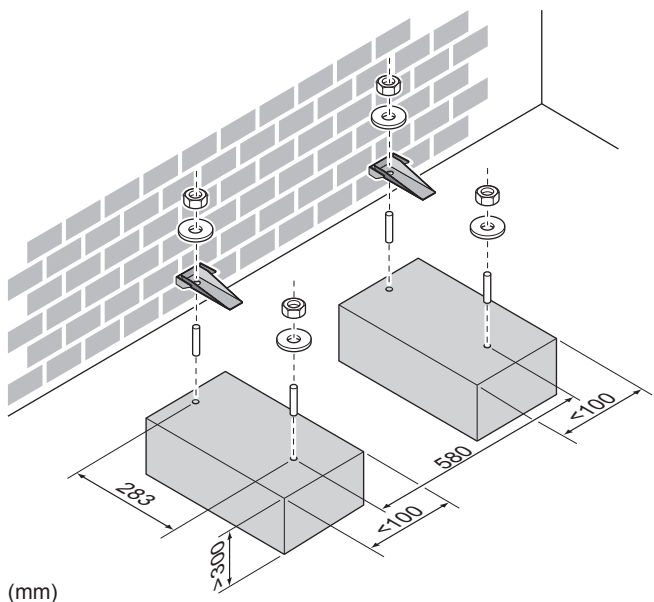
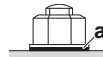

(mm)

In order to guarantee good operation of the unit in areas with risk of snowfall, a minimum of 10 cm needs to be assured below the bottom plate of the unit. It is recommended to construct a pedestal with the same height as the maximum snowfall height. On this pedestal it is then recommended to install the EKFT008CA option kit to guarantee the minimum space of 10 cm below the bottom plate of the unit.

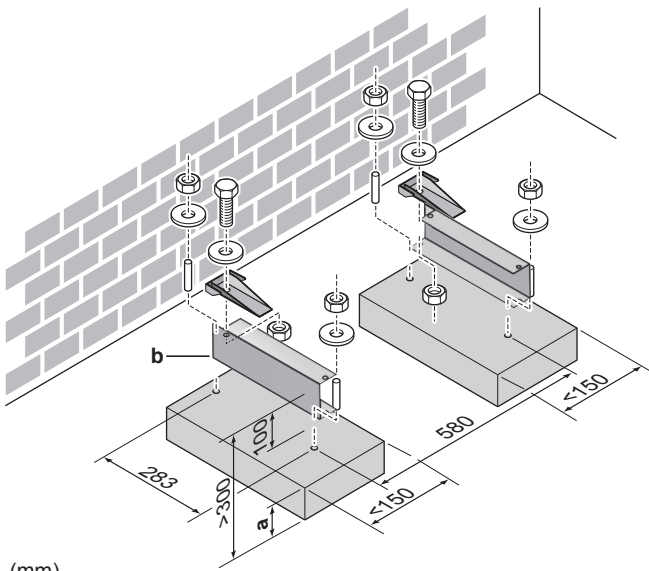

(mm)

- a Maximum snowfall height
- b EKFT008CA option kit

If the unit is installed on brackets to the wall, it is recommended to use the EKFT008CA option kit and to install the unit as follows:

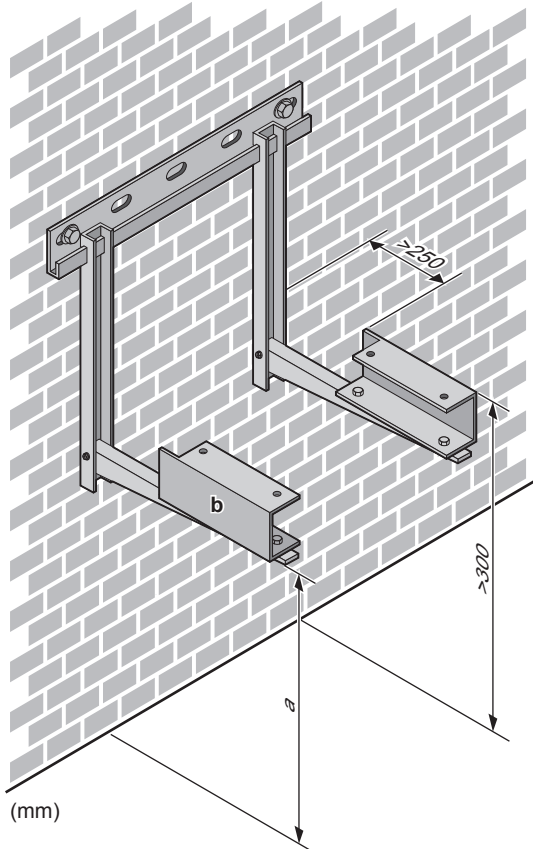
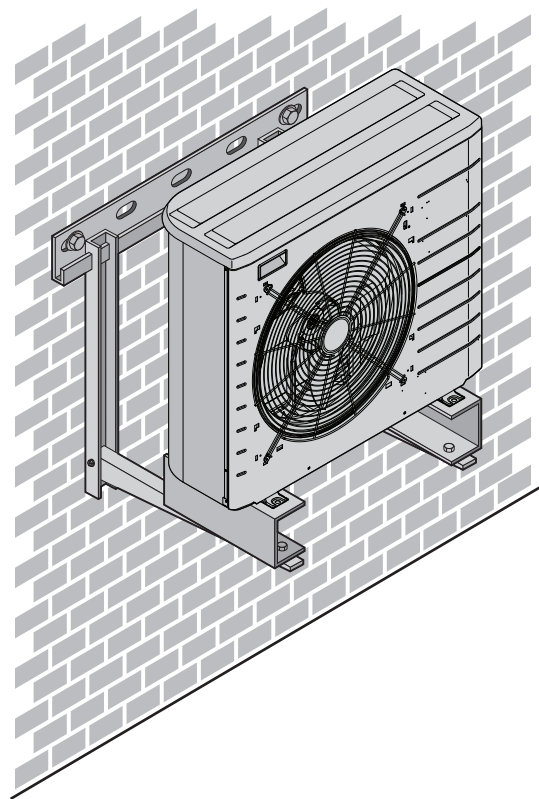

(mm)

- a Maximum snowfall height
- b EKFT008CA option kit

7.3.4 To install the outdoor unit



CAUTION

Do NOT remove the protective cardboard before the unit is installed properly.

- 1 Lift the outdoor unit as described in "3.2.2 To remove the accessories from the outdoor unit" on page 7.
- 2 Install the outdoor unit as follows:

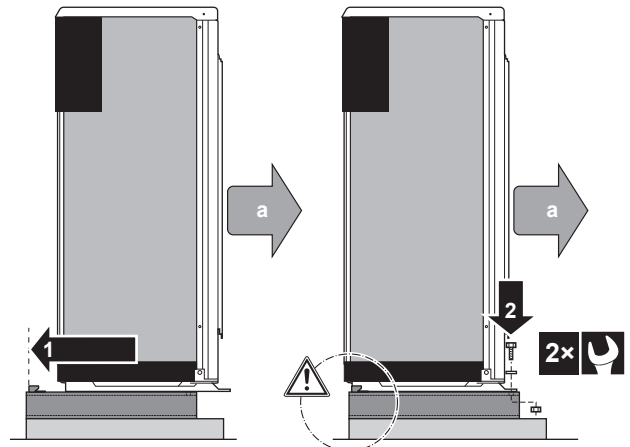

a Air outlet



NOTICE

The pedestal **MUST** be aligned with the backside of the U-beam.

- 3 Remove the protective cardboard and instruction sheet.

7 Installation

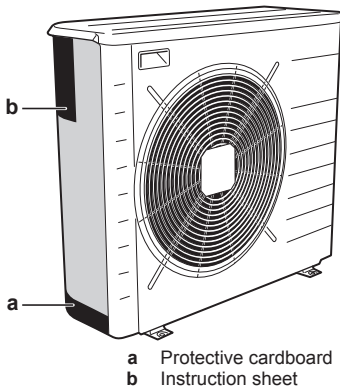

7.3.5 To provide drainage

- Avoid installation places where water leaking from the unit due to a blocked drain pan, cause damage to the location.
- Make sure that condensation water can be evacuated properly.
- Install the unit on a base to make sure that there is a proper drainage in order to avoid ice accumulation.
- Prepare a water drainage channel around the foundation to drain waste water surrounding the unit.
- Avoid drain water flowing over the footpath, so that it does not become slippery in case of ambient freezing temperatures.
- If you install the unit on a frame, install a waterproof plate within 150 mm of the bottom side of the unit in order to prevent the invasion of water in the unit and to avoid the drain water dripping (see the following illustration).

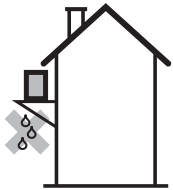

NOTICE

If the drain holes of the outdoor unit are blocked up, provide space of at least 300 mm below the outdoor unit.

An additional drain pan kit (EKDP008CA) can be used to gather the drain water. The drain pan kit consists of:

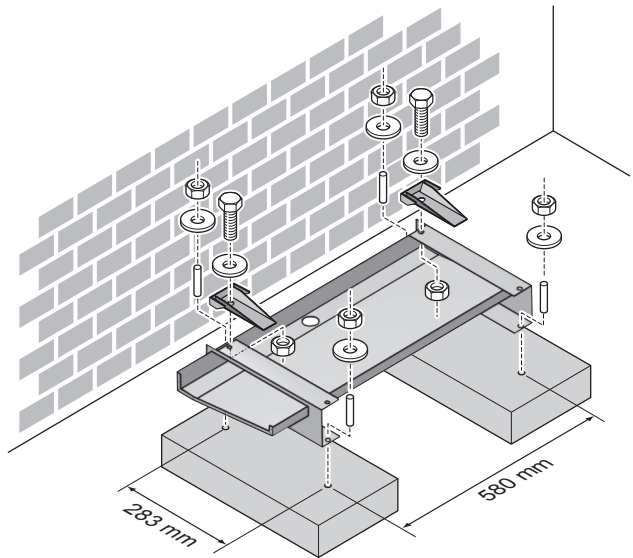
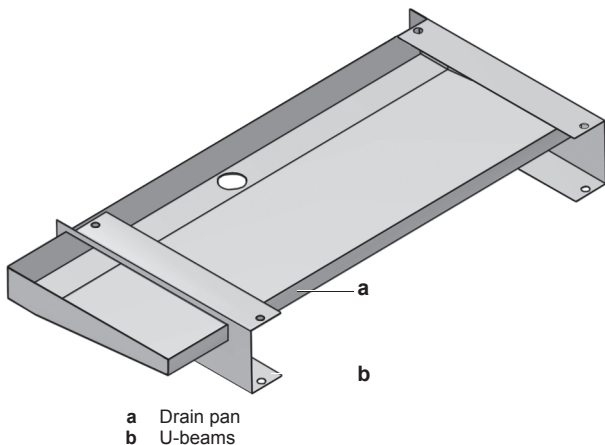

7.3.6 To prevent the outdoor unit from falling over

In case the unit is installed in places where strong wind can tilt the unit, take following measure:

- 1 Prepare 2 cables as indicated in the following illustration (field supply).
- 2 Place the 2 cables over the outdoor unit.
- 3 Insert a rubber sheet between the cables and the outdoor unit to prevent the cable from scratching the paint (field supply).
- 4 Attach the cable's ends. Tighten those ends.

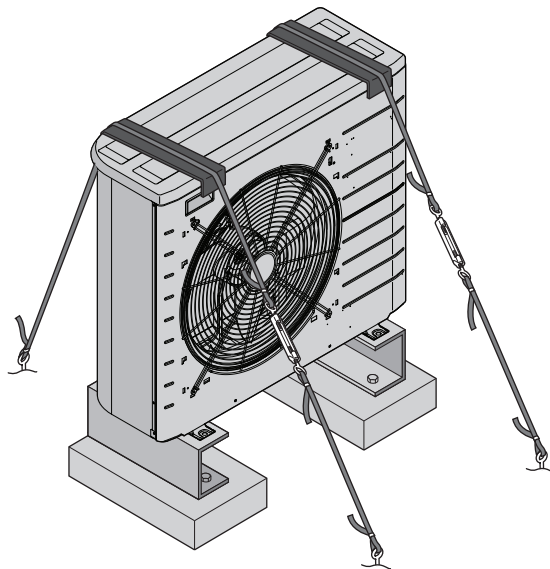

7.4 Mounting the indoor unit

7.4.1 About mounting the indoor unit

When

You have to mount the outdoor and indoor unit before you can connect the refrigerant and water piping.

Typical workflow

Mounting the indoor unit typically consists of the following stages:

- 1 Installing the indoor unit.
- 2 Installing the drain pan kit (optional).

7.4.2 Precautions when mounting the indoor unit



INFORMATION

Also read the precautions and requirements in the following chapters:

- General safety precautions
- Preparation

7.4.3 To install the indoor unit



CAUTION

Do NOT grasp the piping to lift the indoor unit.

- 1 Lift the unit from the package.

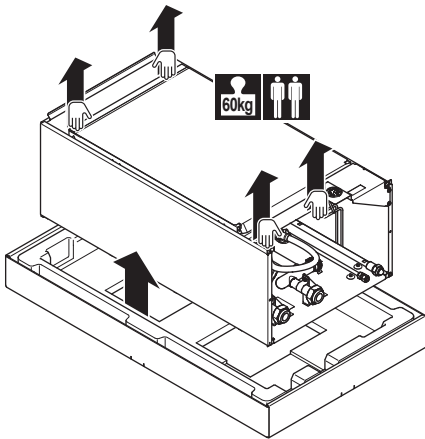

- 2 Remove the 4 screws from the bottom of the unit. Unhook and remove the side plates.

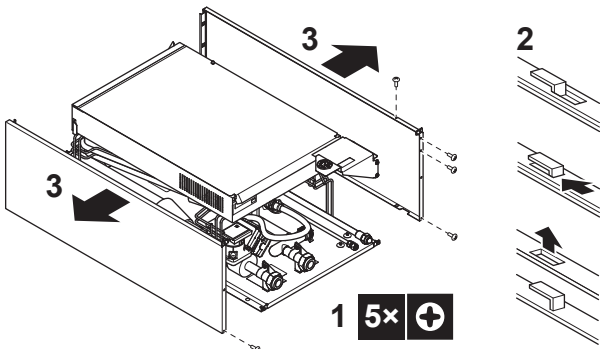

- 3 Put the installation pattern (see packing) on the wall and follow the steps as shown below.

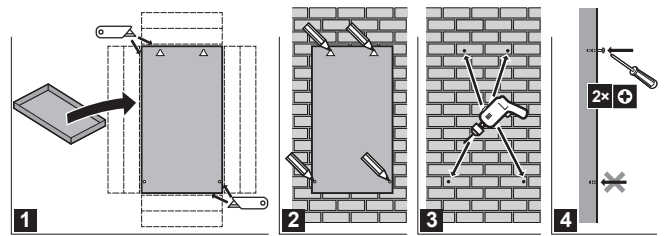

- 4 Lift the unit.

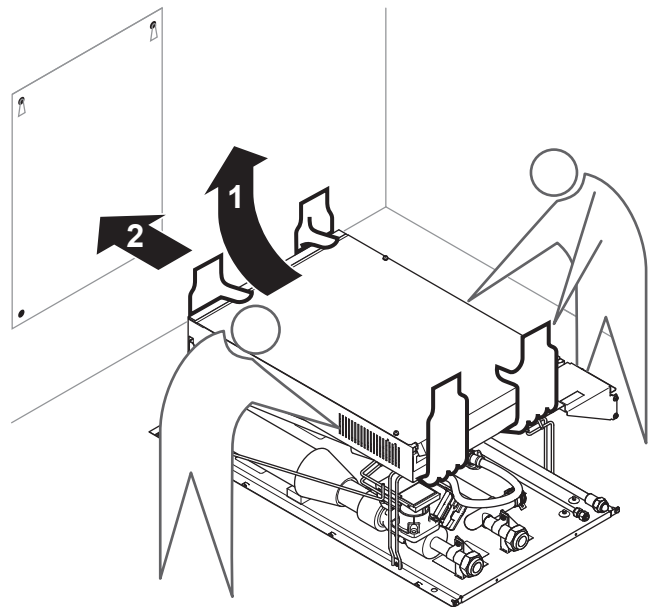

- 5 Tilt the top of the unit against the wall at the position of the 2 inserted screws.

- 6 Hook the unit against the wall.

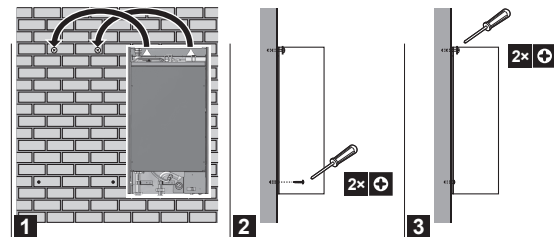

- 7 Assemble the unit.

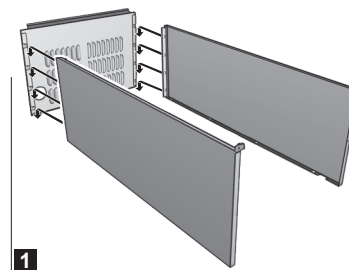

7 Installation

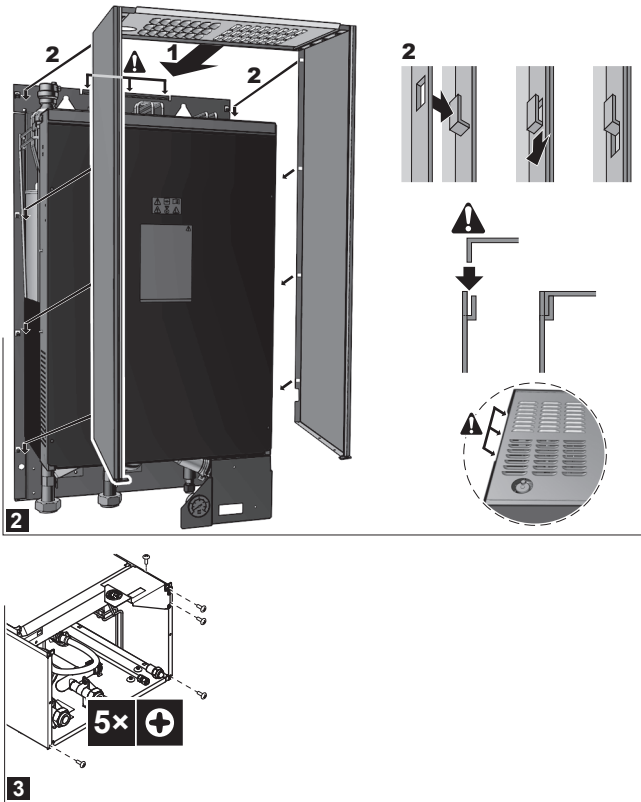

7.4.4 To install the drain pan kit

If a drain pan kit (EKHBDPCA2) is required, install it before connecting the refrigerant and water pipes and the electrical wiring.

To install, see the installation manual of the drain pan kit.

7.5 Connecting the refrigerant piping

7.5.1 About connecting the refrigerant piping

Before connecting the refrigerant piping

Make sure the outdoor and indoor unit are mounted.

Typical workflow

Connecting the refrigerant piping involves:

- Connecting the refrigerant piping to the outdoor unit
- Connecting the refrigerant piping to the indoor unit
- Insulating the refrigerant piping
- Keeping in mind the guidelines for:
 - Pipe bending
 - Flaring pipe ends
 - Brazing
 - Using the stop valves

7.5.2 Precautions when connecting the refrigerant piping



INFORMATION

Also read the precautions and requirements in the following chapters:

- General safety precautions
- Preparation



DANGER: RISK OF BURNING



CAUTION

- Do NOT use mineral oil on flared part.
- Do NOT reuse piping from previous installations.
- NEVER install a drier to this R410A unit to guarantee its lifetime. The drying material may dissolve and damage the system.



NOTICE

Take the following precautions on refrigerant piping into account:

- Avoid anything but the designated refrigerant to get mixed into the refrigerant cycle (e.g. air).
- Only use R410A when adding refrigerant.
- Only use installation tools (e.g. manifold gauge set) that are exclusively used for R410A installations to withstand the pressure and to prevent foreign materials (e.g. mineral oils and moisture) from mixing into the system.
- Install the piping so that the flare is NOT subjected to mechanical stress
- Protect the piping as described in the following table to prevent dirt, liquid or dust from entering the piping.
- Use caution when passing copper tubes through walls (see figure below).

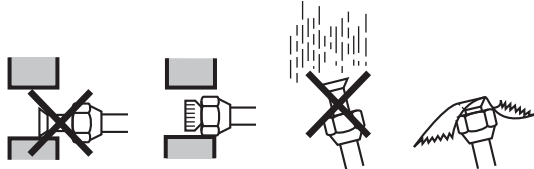

Unit	Installation period	Protection method
Outdoor unit	>1 month	Pinch the pipe
	<1 month	Pinch or tape the pipe
Indoor unit	Regardless of the period	



INFORMATION

Do NOT open the refrigerant stop valve before checking the refrigerant piping. When you need to charge additional refrigerant it is recommended to open the refrigerant stop valve after charging.

7.5.3 Guidelines when connecting the refrigerant piping

Take the following guidelines into account when connecting pipes:

- Coat the flare inner surface with ether oil or ester oil when connecting a flare nut. Tighten 3 or 4 turns by hand, before tightening firmly.

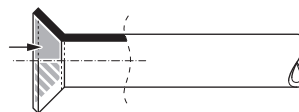

- Always use two wrenches together when loosening a flare nut.
- Always use a spanner and torque wrench together to tighten the flare nut when connecting the piping. This to prevent nut cracking and leaks.

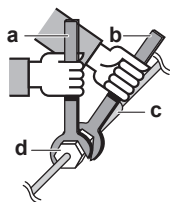

- a Torque wrench
- b Spanner
- c Piping union
- d Flare nut

Piping size (mm)	Tightening torque (N·m)	Flare dimensions (A) (mm)	Flare shape (mm)
Ø6.4	15~17	8.7~9.1	
Ø15.9	63~75	19.3~19.7	

7.5.4 Pipe bending guidelines

Use a pipe bender for bending. All pipe bends should be as gentle as possible (bending radius should be 30~40 mm or larger).

7.5.5 To flare the pipe end



CAUTION

- Incomplete flaring may cause refrigerant gas leakage.
- Do NOT re-use flares. Use new flares to prevent refrigerant gas leakage.
- Use flare nuts that are included with the unit. Using different flare nuts may cause refrigerant gas leakage.

- 1 Cut the pipe end with a pipe cutter.
- 2 Remove burrs with the cut surface facing downward so that the chips do not enter the pipe.

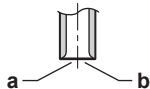

- a Cut exactly at right angles.
- b Remove burrs.

- 3 Remove the flare nut from the stop valve and put the flare nut on the pipe.
- 4 Flare the pipe. Set exactly at the position as shown in the following illustration.

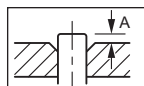

	Conventional flare tool		
	Flare tool for R410A (clutch type)	Clutch type (Ridgid-type)	Wing nut type (Imperial-type)
A	0~0.5 mm	1.0~1.5 mm	1.5~2.0 mm

- 5 Check that the flaring is properly made.

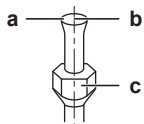

- a Flare's inner surface must be flawless.
- b The pipe end must be evenly flared in a perfect circle.
- c Make sure the flare nut is lifted.

7.5.6 To braze the pipe end

The indoor unit and outdoor unit have flare connections. Connect both ends without brazing. If brazing should be needed, take the following into account:

- When brazing, blow through with nitrogen to prevent creation of large quantities of oxidised film on the inside of the piping. This film adversely affects valves and compressors in the refrigerating system and prevents proper operation.
- Set the nitrogen pressure to 20 kPa (just enough so it can be felt on the skin) with a pressure-reducing valve.

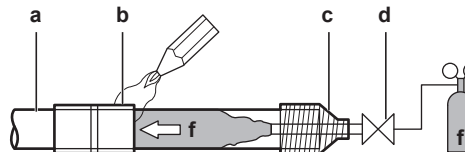

- a Refrigerant piping
- b Part to be brazed
- c Taping
- d Manual valve
- e Pressure-reducing valve
- f Nitrogen

- Do NOT use anti-oxidants when brazing pipe joints. Residue can clog pipes and break equipment.
- Do NOT use flux when brazing copper-to-copper refrigerant piping. Use phosphor copper brazing filler alloy (BCuP), which does not require flux. Flux has an extremely harmful influence on refrigerant piping systems. For instance, if chlorine based flux is used, it will cause pipe corrosion or, in particular, if the flux contains fluorine, it will deteriorate the refrigerant oil.

7.5.7 Using the stop valve and service port

To handle the stop valve

Take the following guidelines into account:

- The stop valves are factory closed.
- The following illustration shows each part required in handling the valve.

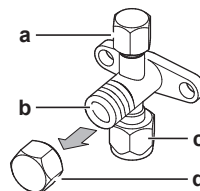

- a Service port and service port cap
- b Valve stem
- c Field piping connection
- d Stem cap

- Keep both stop valves open during operation.
- Do NOT apply excessive force to the valve stem. Doing so may break the valve body.
- Always make sure to secure the stop valve with a spanner, then loosen or tighten the flare nut with a torque wrench. Do NOT place the spanner on the stem cap, as this could cause a refrigerant leak.

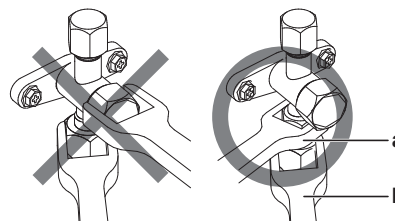

- a Spanner
- b Torque wrench

7 Installation

- When it is expected that the operating pressure will be low (e.g. when cooling will be performed while the outside air temperature is low), sufficiently seal the flare nut in the stop valve on the gas line with silicon sealant to prevent freezing.

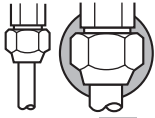

■ Silicon sealant, make sure there is no gap.

To open/close the stop valve

- Remove the valve cover.
- Insert a hexagon wrench (liquid side: 4 mm, gas side: 6 mm) into the valve stem and turn the valve stem:

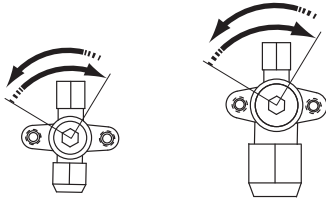

Counterclockwise to open.
Clockwise to close.

- When the valve stem cannot be turned any further, stop turning. The valve is now opened/closed.

To handle the stem cap

Take the following guidelines into account:

- The stem cap is sealed where indicated with the arrow. Do NOT damage it.

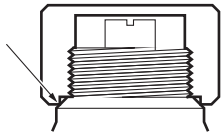

- After handling the stop valve, make sure to tighten the stem cap securely.
- For the tightening torque, refer to the following table.
- Check for refrigerant leaks after tightening the stem cap.

Item	Tightening torque (N·m)
Stem cap, liquid side	13.5~16.5
Stem cap, gas side	22.5~27.5
Service port cap	11.5~13.9

To handle the service cap

Take the following guidelines into account:

- Always use a charge hose equipped with a valve depressor pin, since the service port is a Schrader type valve.
- After handling the service port, tighten the service port cap securely. For the tightening torque, refer to the table in chapter "To handle the stem cap" on page 36.
- Check for refrigerant leaks after tightening the service port cap.

7.5.8 To connect the refrigerant piping to the outdoor unit

- Connect the liquid refrigerant connection from the indoor unit to the liquid stop valve of the outdoor unit.

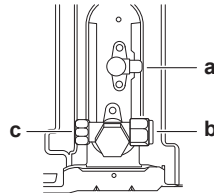
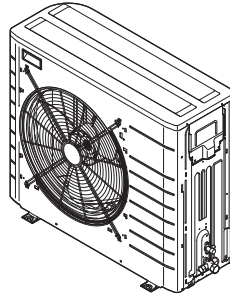

a Liquid stop valve
b Gas stop valve
c Service port

- Connect the gas refrigerant connection from the indoor unit to the refrigerant stop valve of the outdoor unit.

7.5.9 To connect the refrigerant piping to the indoor unit

- Connect the liquid stop valve from the outdoor unit to the refrigerant liquid connection of the indoor unit.

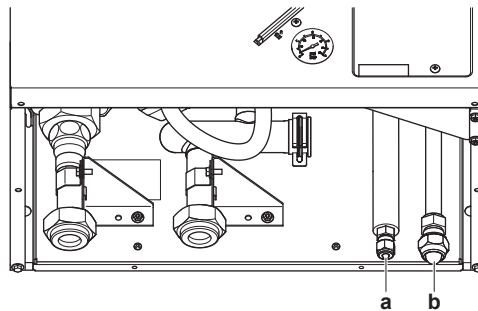

a Refrigerant liquid connection
b Refrigerant gas connection

- Connect the gas stop valve from the outdoor unit to the refrigerant gas connection of the indoor unit.



NOTICE

It is recommended that the refrigerant piping between indoor and outdoor unit is installed in a ducting or the refrigerant piping is wrapped with finishing tape.

7.6 Checking the refrigerant piping

7.6.1 About checking the refrigerant piping

The outdoor unit's **internal** refrigerant piping has been factory tested for leaks. You only have to check the outdoor unit's **external** refrigerant piping.

Before checking the refrigerant piping

Make sure the refrigerant piping is connected between the outdoor unit and the indoor unit.

Typical workflow

Checking the refrigerant piping typically consists of the following stages:

- 1 Checking for leaks in the refrigerant piping.
- 2 Performing vacuum drying to remove all moisture, air or nitrogen from the refrigerant piping.

If there is a possibility of moisture being present in the refrigerant piping (for example, rainwater may have entered the piping), first carry out the vacuum drying procedure below until all moisture has been removed.

7.6.2 Precautions when checking the refrigerant piping

i INFORMATION

Also read the precautions and requirements in the following chapters:

- General safety precautions
- Preparation

! NOTICE

Use a 2-stage vacuum pump with a non-return valve that can evacuate to a gauge pressure of -100.7 kPa (5 Torr absolute). Make sure the pump oil does not flow oppositely into the system while the pump is not working.

! NOTICE

Use this vacuum pump for R410A exclusively. Using the same pump for other refrigerants may damage the pump and the unit.

! NOTICE

- Connect the vacuum pump to the service port of the gas stop valve.
- Make sure that the gas stop valve and liquid stop valve are firmly closed before performing the leak test or vacuum drying.

7.6.3 To check for leaks

! NOTICE

Do NOT exceed the unit's maximum working pressure (see "PS High" on the unit name plate).

! NOTICE

Make sure to use a recommended bubble test solution from your wholesaler. Do not use soap water, which may cause cracking of flare nuts (soap water may contain salt, which absorbs moisture that will freeze when the piping gets cold), and/or lead to corrosion of flared joints (soap water may contain ammonia which causes a corrosive effect between the brass flare nut and the copper flare).

- 1 Charge the system with nitrogen gas up to a gauge pressure of at least 200 kPa (2 bar). It is recommended to pressurize to 3000 kPa (30 bar) in order to detect small leaks.
- 2 Check for leaks by applying the bubble test solution to all connections.
- 3 Discharge all nitrogen gas.

i INFORMATION

After opening the stop valve, it is possible that the pressure in the refrigerant piping does NOT increase. This might be caused by e.g. the closed state of the expansion valve in the outdoor unit circuit, but does NOT present any problem for correct operation of the unit.

7.6.4 To perform vacuum drying

Connect the vacuum pump and manifold as follows:

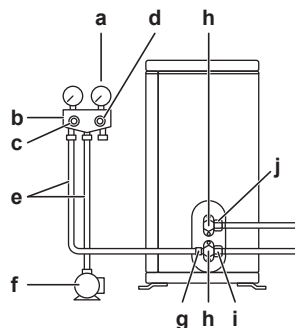

- a Pressure meter
- b Gauge manifold
- c Low-pressure valve (Lo)
- d High-pressure valve (Hi)
- e Charging hoses
- f Vacuum pump
- g Service port
- h Valve lids
- i Gas stop valve
- j Liquid stop valve

- 1 Vacuum the system until the pressure on the manifold indicates -0.1 MPa (-1 bar).
- 2 Leave as is for 4-5 minutes and check the pressure:

If the pressure...	Then...
Does not change	There is no moisture in the system. This procedure is finished.
Increases	There is moisture in the system. Go to the next step.

- 3 Evacuate for at least 2 hours to a pressure on the manifold of -0.1 MPa (-1 bar).
- 4 After turning OFF the pump, check the pressure for at least 1 hour.
- 5 If you do NOT reach the target vacuum or cannot maintain the vacuum for 1 hour, do the following:
 - Check for leaks again.
 - Perform vacuum drying again.

! NOTICE

Be sure to open the gas stop valve after piping installation and vacuuming. Running the system with the valve closed, the compressor may break down.

7 Installation

7.7 Charging refrigerant

7.7.1 About charging refrigerant

The outdoor unit is factory charged with refrigerant, but in some cases the following might be necessary:

What	When
Charging additional refrigerant	When the total liquid piping length is more than specified (see later).
Completely recharging refrigerant	Example: <ul style="list-style-type: none"> When relocating the system. After a leak.

Charging additional refrigerant

Before charging additional refrigerant, make sure the outdoor unit's **external** refrigerant piping is checked (leak test, vacuum drying).



INFORMATION

Depending on the units and/or the installation conditions, it might be necessary to connect electrical wiring before you can charge refrigerant.

Typical workflow – Charging additional refrigerant typically consists of the following stages:

- 1 Determining if and how much you have to charge additionally.
- 2 If necessary, charging additional refrigerant.
- 3 Filling in the fluorinated greenhouse gases label, and fixing it to the inside of the outdoor unit.

Completely recharging refrigerant

Before completely recharging refrigerant, make sure the following is done:

- 1 The system is pumped down.
- 2 The outdoor unit's **external** refrigerant piping is checked (leak test, vacuum drying).
- 3 Vacuum drying on the outdoor unit's **internal** refrigerant piping is performed.



NOTICE

Before completely recharging, perform vacuum drying on the outdoor unit's **internal** refrigerant piping as well.

Typical workflow – Completely recharging refrigerant typically consists of the following stages:

- 1 Determining how much refrigerant to charge.
- 2 Charging refrigerant.
- 3 Filling in the fluorinated greenhouse gases label, and fixing it to the inside of the outdoor unit.

7.7.2 Precautions when charging refrigerant



INFORMATION

Also read the precautions and requirements in the following chapters:

- General safety precautions
- Preparation

7.7.3 To determine the additional refrigerant amount

If the total liquid piping length is...	Then...
≤10 m	Do NOT add additional refrigerant.
>10 m	R=(total length (m) of liquid piping–10 m)×0.020 R=Additional charge (kg)(rounded in units of 0.1 kg)



INFORMATION

Piping length is the one way length of liquid piping.

7.7.4 To determine the complete recharge amount



INFORMATION

If a complete recharge is necessary, the total refrigerant charge is: the factory refrigerant charge (see unit name plate) + the determined additional amount.

7.7.5 To charge refrigerant



WARNING

- Only use R410A as refrigerant. Other substances may cause explosions and accidents.
- R410A contains fluorinated greenhouse gases. Its global warming potential value is 2087.5. Do NOT vent these gases into the atmosphere.
- When charging refrigerant, always use protective gloves and safety glasses.



CAUTION

To avoid compressor breakdown, do NOT charge more than the specified amount of refrigerant.

Prerequisite: Before charging refrigerant, make sure the refrigerant piping is connected and checked (leak test and vacuum drying).

- 1 Connect the refrigerant cylinder to the service port.
- 2 Charge the additional refrigerant amount.
- 3 Open the gas stop valve.

If pump down is needed in case of dismantling or relocating the system, see "[13.2 To pump down](#)" on page 82 for more details.

7.7.6 To fix the fluorinated greenhouse gases label



NOTICE

National implementation of EU regulation on certain fluorinated greenhouse gases may require to provide the appropriate official language on the unit. Therefore, an additional multilingual fluorinated greenhouse gases label is supplied with the unit.

- 1 Fill in the label as follows:

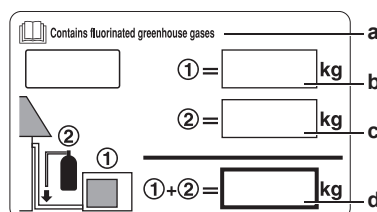

- a From the multilingual fluorinated greenhouse gases label peel off the applicable language and stick it on top of a.

- b Factory refrigerant charge: see unit name plate
- c Additional refrigerant amount charged
- d Total refrigerant charge

- 2 Fix the label on the inside of the outdoor unit near the gas and liquid stop valves.

7.8 Connecting the water piping

7.8.1 About connecting the water piping

Before connecting the water piping

Make sure the outdoor and indoor unit are mounted.

Typical workflow

Connecting the water piping typically consists of the following stages:

- 1 Connecting the water piping of the indoor unit.
- 2 Filling the water circuit.
- 3 Filling the domestic hot water tank.
- 4 Insulating the water piping.

7.8.2 Precautions when connecting the water piping



INFORMATION

Also read the precautions and requirements in the following chapters:

- General safety precautions
- Preparation

7.8.3 To connect the water piping



NOTICE

Do NOT use excessive force when connecting the piping. Deformation of the piping can cause malfunctioning of the unit.

To facilitate service and maintenance, 2 shut-off valves are provided. Mount the valves on the water inlet and on the water outlet. Mind their position: the integrated drain valves will only drain the side of the circuit on which they are located. To be able to only drain the unit, make sure the drain valves are positioned between the shut-off valves and the unit.

- 1 Install the shut-off valves on the water pipes.

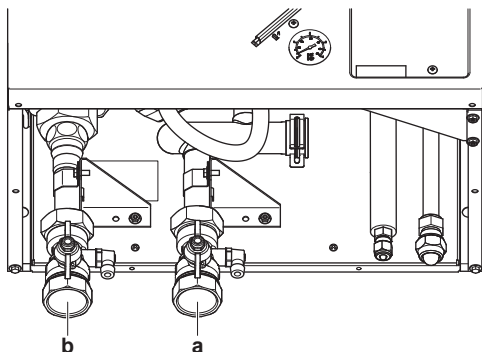

- a Water inlet
- b Water outlet



NOTICE

To avoid damage to the surroundings in case of water leakage, it is recommended to close the cold water inlet shut-off valves during periods of absence.

- 2 Screw the indoor unit nuts on the shut-off valves.
- 3 Connect the field piping on the shut-off valves.

- 4 In case of connection with the optional domestic hot water tank, see the installation manual of the domestic hot water tank.



NOTICE

- A drain device and pressure relief device should be installed on the cold water inlet connection of the domestic hot water cylinder.
- To avoid back siphonage, it is recommended to install a non-return valve on the water inlet of the domestic hot water tank in accordance with the applicable legislation.
- It is recommended to install a pressure reducing valve on the cold water inlet in accordance with the applicable legislation.
- An expansion vessel should be installed on the cold water inlet in accordance with the applicable legislation.
- It is recommended to install the pressure relief valve on higher position as top of the domestic hot water tank. Heating of the domestic hot water tank causes water to expand and without pressure relief valve the water pressure inside the tank can rise above the tank design pressure. Also the field installation (piping, tapping points, etc.) connected to the tank is subjected to this high pressure. To prevent this, a pressure relieve valve needs to be installed. The overpressure prevention depends on the correct operation of the field installed pressure relief valve. If this is NOT working correctly, overpressure will deform the tank and water leakage may occur. To confirm good operation, regular maintenance is required.

7.8.4 To fill the water circuit

- 1 Connect the water supply hose to the drain and fill valve.

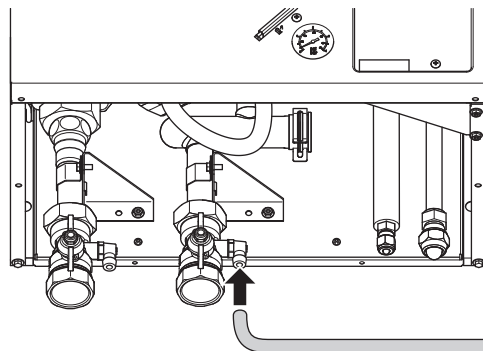

- 2 Open the drain and fill valve.
- 3 Make sure that the automatic air purge valve is open (at least 2 turns).



INFORMATION

For location of the air purge valve, see "Components: Indoor unit" in chapter "14 Technical data" on page 84.

- 4 Fill the circuit with water until the manometer indicates a pressure of ± 2.0 bar.
- 5 Purge as much air as possible from the water circuit.
- 6 Close the drain and fill valve.
- 7 Disconnect the water supply hose from the drain and fill valve.



NOTICE

The water pressure indicated on the manometer will vary depending on the water temperature (higher pressure at higher water temperature).

However, at all times water pressure shall remain above 1 bar to avoid air entering the circuit.

7 Installation

7.8.5 To fill the domestic hot water tank

For installation instructions, see the installation manual of the domestic hot water tank.

7.8.6 To insulate the water piping

The piping in the complete water circuit MUST be insulated to prevent condensation during cooling operation and reduction of the heating and cooling capacity.

If the temperature is higher than 30°C and the humidity is higher than RH 80%, the thickness of the insulation materials should be at least 20 mm to prevent condensation on the surface of the insulation.

7.9 Connecting the electrical wiring

7.9.1 About connecting the electrical wiring

Before connecting the electrical wiring

Make sure:

- The refrigerant piping is connected and checked
- The water piping is connected

Typical workflow

Connecting the electrical wiring typically consists of the following stages:

- 1 Making sure the power supply system complies with the electrical specifications of the heat pump.
- 2 Connecting the electrical wiring to the outdoor unit.
- 3 Connecting the electrical wiring to the indoor unit.
- 4 Connecting the main power supply.
- 5 Connecting the backup heater power supply.
- 6 Connecting the user interface.
- 7 Connecting the shut-off valves.
- 8 Connecting the electrical meters.
- 9 Connecting the domestic hot water pump.
- 10 Connecting the alarm output.
- 11 Connecting the space cooling/heating ON/OFF output.
- 12 Connecting the changeover to an external heat source.
- 13 Connecting the power consumption digital inputs.

7.9.2 About electrical compliance

Only for ERLQ006CAV3+ERLQ008CAV3

Equipment complying with EN/IEC 61000-3-12 (European/International Technical Standard setting the limits for harmonic currents produced by equipment connected to public low-voltage systems with input current >16 A and ≤75 A per phase.).

Only for indoor units

See "7.9.8 To connect the backup heater power supply" on page 43.

7.9.3 Precautions when connecting the electrical wiring

i INFORMATION

Also read the precautions and requirements in the following chapters:

- General safety precautions
- Preparation



DANGER: RISK OF ELECTROCUTION



INFORMATION

More information about the legend and the location of the wiring diagram of the unit can be found in "14.6 Wiring diagram" on page 92.



WARNING

ALWAYS use multicore cable for power supply cables.

7.9.4 Guidelines when connecting the electrical wiring

Keep the following in mind:

- If stranded conductor wires are being used, install a round crimp-style terminal on the tip. Place the round crimp-style terminal on the wire up to the covered part and fasten the terminal with the appropriate tool.

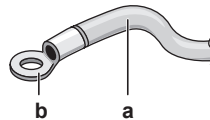

- a Stranded conductor wire
- b Round crimp-style terminal

- Use the following methods for installing wires:

Wire type	Installation method
Single core wire	<p>a Curled single core wire b Screw c Flat washer</p>
Stranded conductor wire with round crimp-style terminal	<p>a Terminal b Screw c Flat washer</p>

NOTICE

Precautions when laying power wiring:

- Do not connect wiring of different thicknesses to the power terminal block (slack in the power wiring may cause abnormal heat).
- When connecting wiring which is the same thickness, do as shown in the figure below.



- For wiring, use the designated power wire and connect firmly, then secure to prevent outside pressure being exerted on the terminal board.
- Use an appropriate screwdriver for tightening the terminal screws. A screwdriver with a small head will damage the head and make proper tightening impossible.
- Over-tightening the terminal screws may break them.

Tightening torques

Item	Tightening torque (N·m)
M4 (X1M)	1.2~1.5
M4 (earth)	

7.9.5 To connect the electrical wiring on the outdoor unit

- Remove the 2 switch box cover screws.
- Remove the switch box cover.

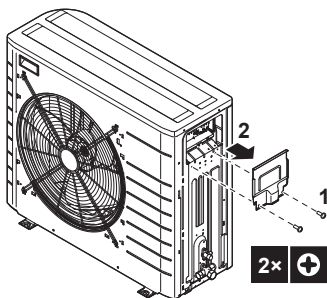

- Strip insulation (20 mm) from the wires.



- a Strip wire end to this point
- b Excessive strip length may cause electrical shock or leakage.

- Open the wire clamp.

- Connect the interconnection cable and power supply as follows:

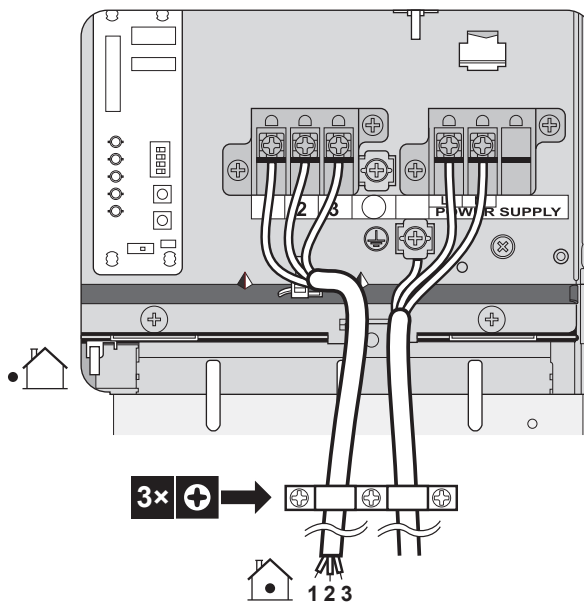

- Install the switch box cover.

7.9.6 To connect the electrical wiring on the indoor unit

- To open the indoor unit, see "7.2.3 To open the indoor unit" on page 30.
- Wiring should enter the unit from the bottom.
- Routing of the wiring inside the unit should be as follows:

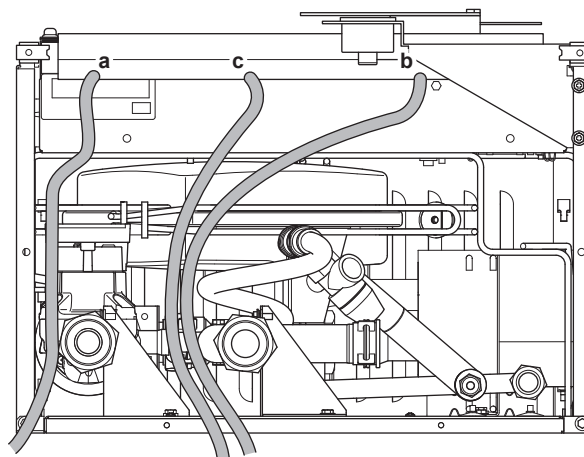

INFORMATION

When installing field supply or option cables, foresee sufficient cable length. This will make it possible to remove/reposition the switch box and gain access to other components during service.

Routing	Possible cables (depending on unit type and installed options)
a Low voltage	<ul style="list-style-type: none"> Preferential power supply contact User interface Domestic hot water tank thermistor (option) Power consumption digital inputs (field supply) Outdoor ambient temperature sensor (option) Indoor ambient temperature sensor (option) Electrical meters (field supply)

7 Installation

Routing	Possible cables (depending on unit type and installed options)
b High voltage power supply	<ul style="list-style-type: none"> Interconnection cable Normal kWh rate power supply Preferential kWh rate power supply Power supply for backup heater Power supply for bottom plate heater (option) Power supply for booster heater (to indoor unit) Power supply for booster heater and thermal protection (from indoor unit)
c High voltage control signal	<ul style="list-style-type: none"> Heat pump convector (option) Room thermostat (option) 3-way valve Shut-off valve (field supply) Domestic hot water pump (field supply) Alarm output Changeover to external heat source control Space heat/cool operation control

- 4 Fix the cable with cable ties to the cable tie mountings to ensure strain relief and to make sure that it does NOT come in contact with the piping and sharp edges.



CAUTION

Do NOT push or place redundant cable length in the unit.

7.9.7 To connect the main power supply

- 1 Connect the main power supply.

In case of normal kWh rate power supply

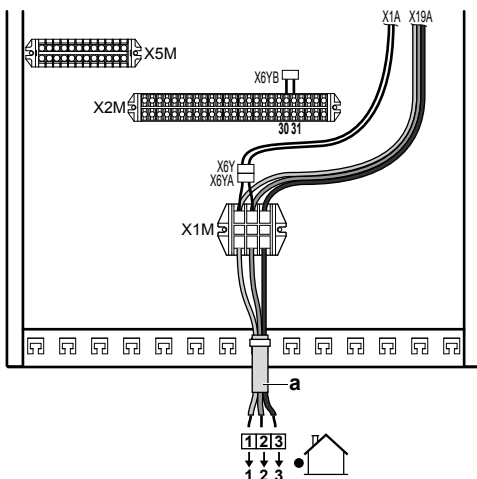

Legend: see illustration below.

In case of preferential kWh rate power supply

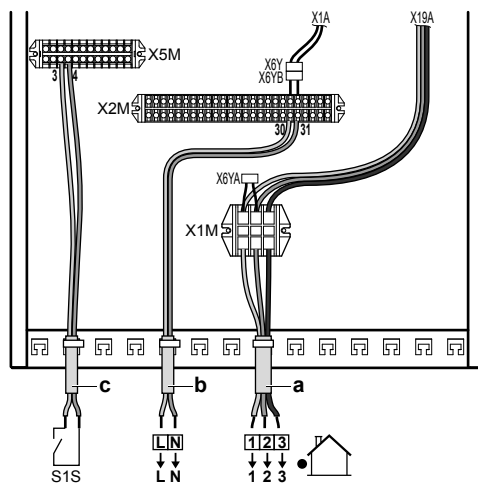

- a Interconnection cable (=main power supply)
b Normal kWh rate power supply
c Preferential power supply contact

- 2 Fix the cable with cable ties to the cable tie mountings.



INFORMATION

In case of preferential kWh rate power supply, the necessity of separate normal kWh rate power supply to indoor unit (b) X2M30/31 depends on the type of preferential kWh rate power supply.

Separate connection to the indoor unit is required:

- if preferential kWh rate power supply is interrupted when active, OR
- if no power consumption of the indoor unit is allowed at the preferential kWh rate power supply when active.

7.9.8 To connect the backup heater power supply

**CAUTION**

To guarantee the unit is completely earthed, always connect the backup heater power supply and the earth cable.

**CAUTION**

If the indoor unit has a tank with a built-in electrical booster heater (EKHW), use a dedicated power circuit for the backup heater and booster heater. NEVER use a power circuit shared by another appliance. This power circuit must be protected with the required safety devices according to the applicable legislation.

**CAUTION**

To guarantee the unit is completely earthed, always connect the backup heater power supply and the earth cable.

The backup heater capacity can vary, depending on the indoor unit model. Make sure that the power supply is in accordance with the backup heater capacity, as listed in the table below.

Backup heater type	Backup heater capacity	Power supply	Maximum running current	$Z_{max}(\Omega)$
*3V	3 kW	1~ 230 V	13 A	—
*9W	3 kW	1~ 230 V	13 A	—
	6 kW	1~ 230 V	26 A ^{(a)(b)}	—
	6 kW	3~ 230 V	15 A	—
	6 kW	3N~ 400 V	8.6 A	—
	9 kW	3N~ 400 V	13 A	—

- (a) Equipment complying with EN/IEC 61000-3-12 (European/International Technical Standard setting the limits for harmonic currents produced by equipment connected to public low-voltage systems with input current >16 A and ≤75 A per phase.).
- (b) This equipment complies with EN/IEC 61000-3-11 (European/International Technical Standard setting the limits for voltage changes, voltage fluctuations and flicker in public low-voltage supply systems for equipment with rated current ≤75 A) provided that the system impedance Z_{sys} is less than or equal to Z_{max} at the interface point between the user's supply and the public system. It is the responsibility of the installer or user of the equipment to ensure, by consultation with the distribution network operator if necessary, that the equipment is connected only to a supply with a system impedance Z_{sys} less than or equal to Z_{max} .

- 1 Connect the backup heater power supply. For *3V models, a double-pole fuse is used for F1B. For *9W models, a 4-pole fuse is used for F1B.
- 2 If required, modify the connections on terminals X6M and X7M.

Backup heater type	Connections to backup heater power supply	Connections to terminals
3 kW 1~ 230 V (*3V)		—

Backup heater type	Connections to backup heater power supply	Connections to terminals
3 kW 1~ 230 V (*9W)		
6 kW 1~ 230 V (*9W)		
6 kW 3~ 230 V (*9W)		
6 kW 3N~ 400 V (*9W) 9 kW 3N~ 400 V (*9W)		

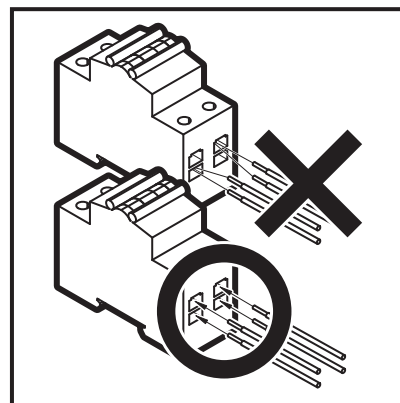
Special remark for fuses:**Special remark for terminals:**

As mentioned on the table above, the connections on the terminals X6M and X7M need to be changed to configure a backup heater. Refer to the illustration below as a caution about handling the terminals.

7 Installation

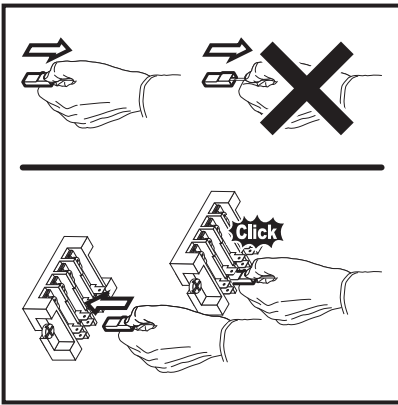

- 3 Fix the cable with cable ties to the cable tie mountings.
- 4 Configure the user interface for the respective power supply. See "8.2.2 Quick wizard: Standard" on page 49.

During connection of the backup heater, miswiring is possible. To detect possible miswiring, it is highly recommended to measure the resistance value of the heater elements. Depending on the different backup heater types, following resistance values (see table below) should be measured. ALWAYS measure the resistance on the contactor clamps K1M, K2M, and K5M.

		3 kW 1~ 230 V	6 kW 1~ 230 V	6 kW 3~ 230 V	6 kW 3N~ 400 V	9 kW 3N~ 400 V
K1M/1	K5M/13	52.9Ω	52.9Ω	52.9Ω	∞	∞
	K1M/3	∞	∞	∞	105.8Ω	105.8Ω
	K1M/5	∞	∞	∞	105.8Ω	105.8Ω
K1M/3	K1M/5	26.5Ω	26.5Ω	26.5Ω	105.8Ω	105.8Ω
K2M/1	K5M/13	∞	26.5Ω	26.5Ω	∞	∞
	K2M/3	∞	∞	∞	52.9Ω	52.9Ω
	K2M/5	∞	∞	∞	52.9Ω	52.9Ω
K2M/3	K2M/5	52.9Ω	52.9Ω	52.9Ω	52.9Ω	52.9Ω
K1M/5	K2M/1	∞	∞	∞	∞	∞

Example measure resistance between K1M/1 and K5M/13:

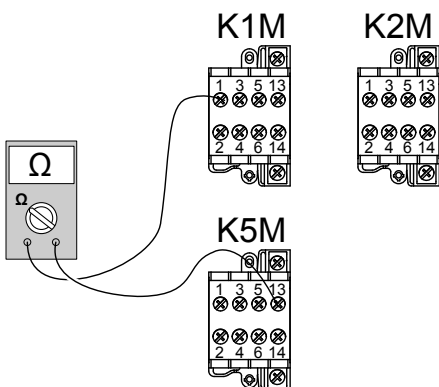

7.9.9 To connect the user interface

- If you use 1 user interface, you can install it at the indoor unit (for control close to the indoor unit), or in the room (when used as room thermostat).
- If you use 2 user interfaces, you can install 1 user interface at the indoor unit (for control close to the indoor unit) + 1 user interface in the room (used as room thermostat).

The procedure differs slightly depending on where you install the user interface.

#	At the indoor unit	In the room
1	<p>Connect the user interface cable to the indoor unit. Fix the cable with cable ties to the cable tie mountings.</p> <p>a Main user interface^(a) b Optional user interface</p>	
2	<p>Insert a screwdriver into the slots underneath the user interface and carefully separate the faceplate from the wallplate. The PCB is mounted in the faceplate of the user interface. Be careful NOT to damage it.</p>	
3	<p>Fix the wallplate of the user interface to the sheet metal of the unit. Be careful NOT to distort the shape of the backside of the user interface by overtightening the mounting screws.</p>	<p>Fix the wallplate of the user interface to the wall.</p>
4	<p>Connect as shown in 4A.</p>	<p>Connect as shown in 4A, 4B, 4C or 4D.</p>
5	<p>Reinstall the faceplate onto the wallplate. Be careful NOT to pinch the wiring when attaching the frontplate to the unit.</p>	

(a) The main user interface is required for operation, but has to be ordered separately (mandatory option).

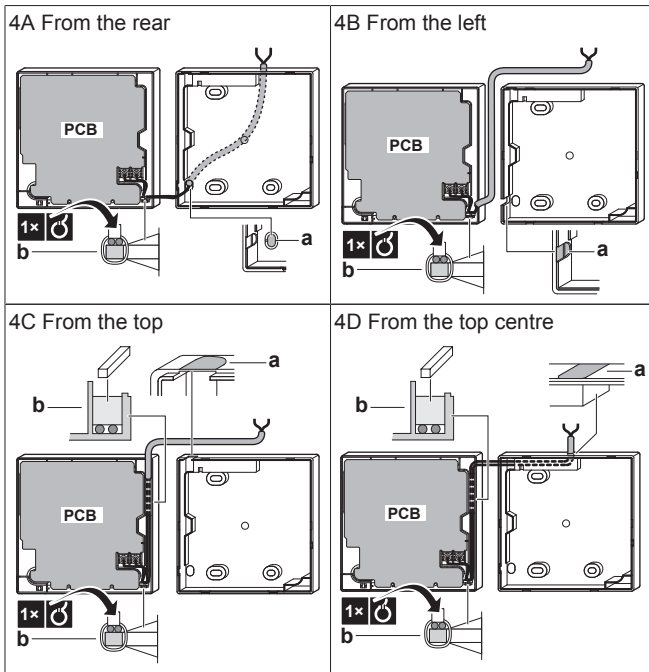

- a Notch this part for the wiring to pass through with nippers etc.
- b Secure the wiring to the front part of the casing using the wiring retainer and clamp.

7.9.10 To connect the shut-off valve

- 1 Connect the valve control cable to the appropriate terminals as shown in the illustration below.



NOTICE

Wiring is different for a NC (normal closed) valve and a NO (normal open) valve.

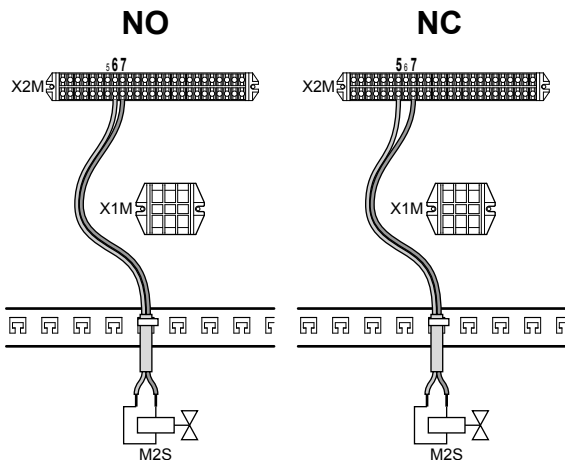

- 2 Fix the cable with cable ties to the cable tie mountings.

7.9.11 To connect the electrical meters



INFORMATION

In case of an electrical meter with transistor output, check the polarity. The positive polarity MUST be connected to X5M/7 and X5M/9; the negative polarity to X5M/8 and X5M/10.

- 1 Connect the electrical meters cable to the appropriate terminals as shown in the illustration below.

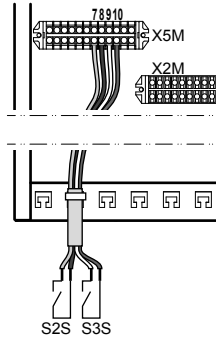

- 2 Fix the cable with cable ties to the cable tie mountings.

7.9.12 To connect the domestic hot water pump

- 1 Connect the domestic hot water pump cable to the appropriate terminals as shown in the illustration below.

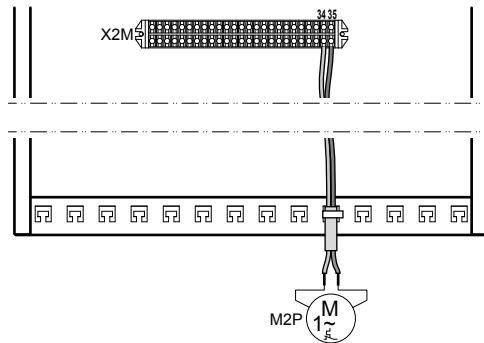

- 2 Fix the cable with cable ties to the cable tie mountings.

7.9.13 To connect the alarm output

- 1 Connect the alarm output cable to the appropriate terminals as shown in the illustration below.

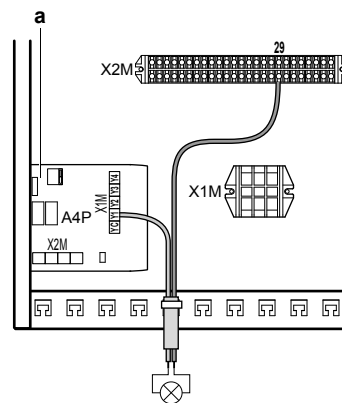

- a Installation of EKRPH1B is required.
- 2 Fix the cable with cable ties to the cable tie mountings.

7 Installation

7.9.14 To connect the space cooling/heating ON/OFF output

- 1 Connect the space cooling/heating ON/OFF output cable to the appropriate terminals as shown in the illustration below.

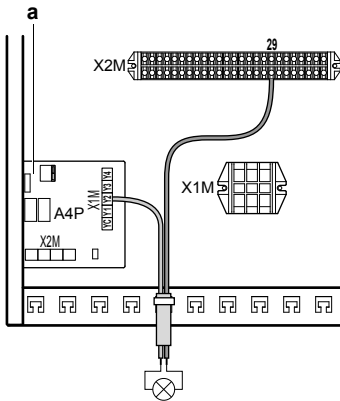

a Installation of EKR P1HB is required.

- 2 Fix the cable with cable ties to the cable tie mountings.

7.9.15 To connect the changeover to external heat source

- 1 Connect the changeover to external heat source cable to the appropriate terminals as shown in the illustration below.

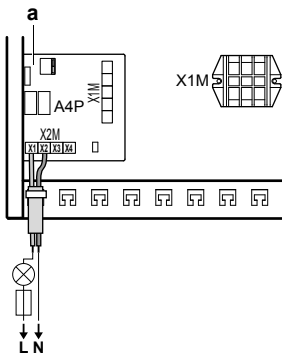

a Installation of EKR P1HB is required.

- 2 Fix the cable with cable ties to the cable tie mountings.

7.9.16 To connect the power consumption digital inputs

- 1 Connect the power consumption digital inputs cable to the appropriate terminals as shown in the illustration below.

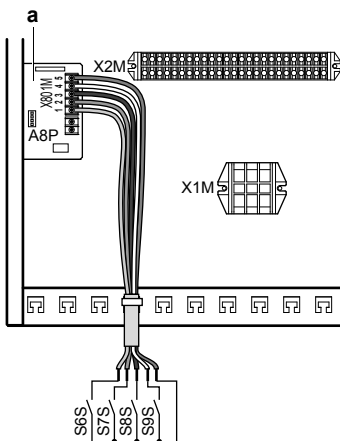

a Installation of EKR P1AHTA is required.

- 2 Fix the cable with cable ties to the cable tie mountings.

7.10 Finishing the outdoor unit installation

7.10.1 To finish the outdoor unit installation

- 1 Insulate and fix the refrigerant piping and interconnection cable as follows:

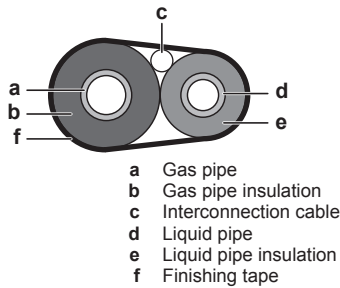

- 2 Install the service cover.

7.10.2 To close the outdoor unit

- 1 Close the switch box cover.
- 2 Close the service cover.



NOTICE

When closing the outdoor unit cover, make sure that the tightening torque does NOT exceed 4.1 N•m.

7.11 Finishing the indoor unit installation

7.11.1 To fix the user interface cover to the indoor unit

- 1 Make sure that the front panel is removed from the indoor unit. See "7.2.3 To open the indoor unit" on page 30.
- 2 Plug the user interface cover into the hinges.

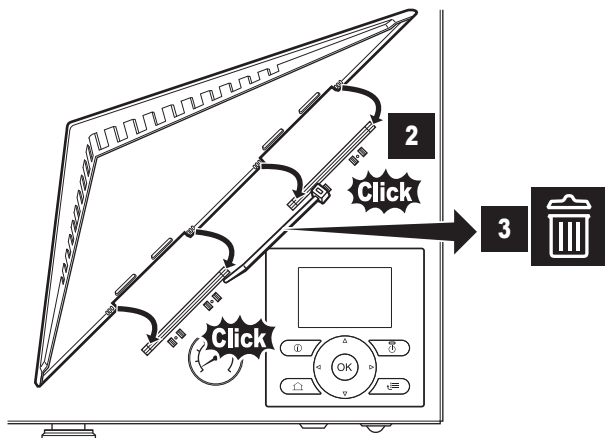

- 3 Mount the front panel to the indoor unit.

7.11.2 To close the indoor unit

- 1 Close the switch box cover.
- 2 Reinstall the front panel.



NOTICE

When closing the indoor unit cover, make sure that the tightening torque does NOT exceed 4.1 N•m.

8 Configuration

8.1 Overview: Configuration

This chapter describes what you have to do and know to configure the system after it is installed.

Why

If you do NOT configure the system correctly, it might NOT work as expected. The configuration influences the following:

- The calculations of the software
- What you can see on and do with the user interface

How

You can configure the system using two different methods.

Method	Description
Configuring via the user interface	First time – Quick wizard. When you turn ON the user interface for the first time (via the indoor unit), a quick wizard starts to help you configure the system. Afterwards. If necessary, you can make changes to the configuration afterwards.
Configuring via the PC configurator	You can prepare the configuration off-site on PC and afterwards upload the configuration to the system with the PC configurator. See also: " 8.1.1 To connect the PC cable to the switch box " on page 47.



INFORMATION

When the installer settings are changed, the user interface will request to confirm. When confirmed, the screen will shortly turn OFF and "busy" will be displayed for several seconds.

Accessing settings – Legend for tables

You can access the installer settings using two different methods. However, NOT all settings are accessible via both methods. If so, the corresponding table columns in this chapter are set to N/A (not applicable).

Method	Column in tables
Accessing settings via the breadcrumb in the menu structure .	#
Accessing settings via the code in the overview settings .	Code

See also:

- "[To access the installer settings](#)" on page 47
- "[8.5 Menu structure: Overview installer settings](#)" on page 72

8.1.1 To connect the PC cable to the switch box

Prerequisite: The EKPCCAB kit is required.

- 1 Connect the cable with USB connection to your PC.
- 2 Connect the plug of the cable to X10A on A1P of the switch box of the indoor unit.

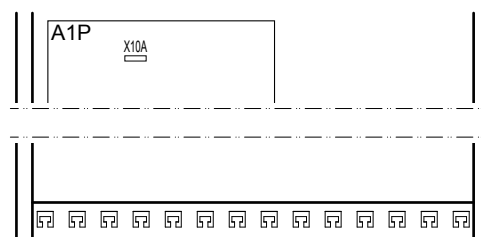

- 3 Pay special attention to the position of the plug!

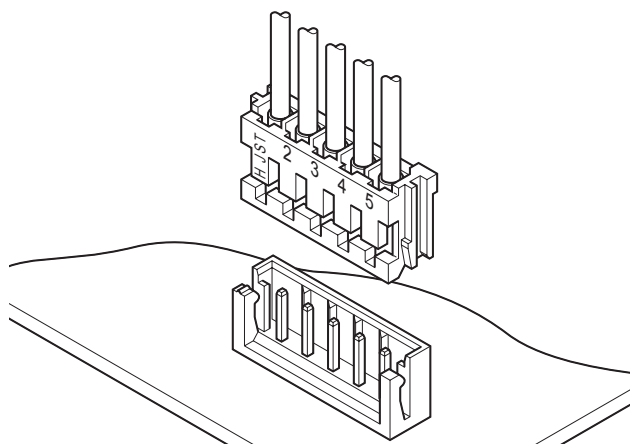

8.1.2 To access the most used commands

To access the installer settings

- 1 Set the user permission level to Installer.
- 2 Go to [A]: > Installer settings.

To access the overview settings

- 1 Set the user permission level to Installer.
- 2 Go to [A.8]: > Installer settings > Overview settings.

To set the user permission level to Installer

- 1 Set the user permission level to Adv. end user.
- 2 Go to [6.4]: > Information > User permission level.
- 3 Press for more than 4 seconds.
Result: is displayed on the home pages.
- 4 If you do NOT press any button for more than 1 hour or press again for more than 4 seconds, the installer permission level switches back to End user.

To set the user permission level to Advanced end user

- 1 Go to the main menu or any of its submenus: .
- 2 Press for more than 4 seconds.

Result: The user permission level switches to Adv. end user. Additional information is displayed and "+" is added to the menu title. The user permission level will stay in Adv. end user until set otherwise.

To set the user permission level to End user

- 1 Press for more than 4 seconds.

Result: The user permission level switches to End user. The user interface will return to the default home screen.

8 Configuration

To modify an overview setting

Example: Modify [1-01] from 15 to 20.

- 1 Go to [A.8]: > Installer settings > Overview settings.
- 2 Go to the corresponding screen of the first part of the setting by using the and button.



INFORMATION

An additional 0-digit is added to the first part of the setting when you access the codes in the overview settings.

Example: [1-01]: "1" will result in "01".

Overview settings				
		01		
00	01	15	02	03
04	05	06	07	
08	09	0a	0b	
0c	0d	0e	0f	
OK Confirm Adjust Scroll				

- 3 Go to the corresponding second part of the setting by using the and button.

Overview settings				
		01		
00	01	15	02	03
04	05	06	07	
08	09	0a	0b	
0c	0d	0e	0f	
OK Confirm Adjust Scroll				

Result: The value to be modified is now highlighted.

- 4 Modify the value by using the and button.

Overview settings				
		01		
00	01	20	02	03
04	05	06	07	
08	09	0a	0b	
0c	0d	0e	0f	
OK Confirm Adjust Scroll				

- 5 Repeat previous steps if you have to modify other settings.
- 6 Push to confirm the modification of the parameter.
- 7 At installer settings menu, press to confirm the settings.

Installer settings	
The system will restart.	
	Cancel
OK Confirm Adjust	

Result: The system will restart.

8.1.3 To copy the system settings from the first to the second user interface

If a second user interface is connected, the installer must first proceed below instructions for the proper configuration of the 2 user interfaces.

This procedure offers you also the possibility to copy the language set from one user interface to the other one: e.g. from EKRUCAL2 to EKRUCAL1.

This procedure offers you also the possibility to copy the language set from one user interface to the other one: e.g. from EKRUCBL2 to EKRUCBL1.

- 1 When power is turned on for the first time, both user interfaces display:

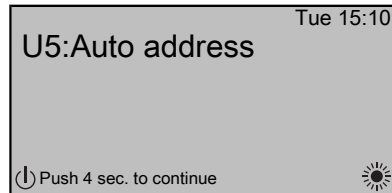

- 2 Push for 4 seconds on the user interface on which you want to proceed to the quick wizard. This user interface is now the main user interface.



INFORMATION

During the quick wizard, the second user interface displays Busy and will NOT be possible to operate.

- 3 The quick wizard will guide you.
- 4 For proper operation of the system, the local data on the two user interfaces must be the same. If this is NOT the case, both user interfaces will display:

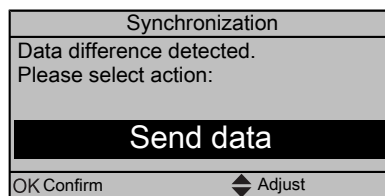

- 5 Select the required action:
 - Send data: the user interface you are operating contains the correct data and the data on the other user interface will be overwritten.
 - Receive data: the user interface you are operating does NOT contain the correct data and the data on the other user interface will be used to overwrite.
- 6 The user interface requests confirmation if you are sure to proceed.

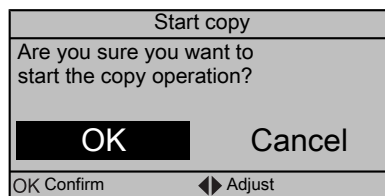

- 7 Confirm the selection on the screen by pushing and all data (languages, schedules etc.) will be synchronised from the selected source user interface to the other one.



INFORMATION

- During the copying, both controllers will NOT allow operation.
- The copy operation can take up until 90 minutes.
- It is recommended to change installer settings, or the configuration of the unit, on the main user interface. If not, it can take up to 5 minutes before these changes are visible in the menu structure.

- 8 Your system is now set to be operated by the 2 user interfaces.

8.1.4 To copy the language set from the first to the second user interface

See "8.1.3 To copy the system settings from the first to the second user interface" on page 48.

8.1.5 Quick wizard: Set the system layout after first power ON

After first power ON of the system, you are guided on the user interface to do initial settings:

- language,
- date,
- time,
- system layout.

By confirming the system layout, you can proceed with the installation and commissioning of the system.

- 1 At power ON, the quick wizard starts as long as the system layout was NOT confirmed yet, by setting the language.

Language	
Select the desired language	
[Redacted]	
OK Confirm	Adjust

- 2 Set the current date and time.

Date	
What is the date today?	
Sun 1 Jan 2012	
OK Confirm	Adjust Scroll

Time	
What is the current time?	
00 : 00	
OK Confirm	Adjust Scroll

- 3 Set the system layout settings: Standard, Options, Capacities. For more details, see ["8.2 Basic configuration" on page 49](#).

A.2 System layout 1	
Standard	
Options	
Capacities	
Confirm layout	
OK Select	Scroll

- 4 After configuration, select Confirm layout and press **OK**.

Confirm layout	
Please confirm the system layout. The system will restart and will be ready for first startup.	
OK	Cancel
OK Confirm	Adjust

- 5 The user interface re-initialises and you can proceed the installation by setting the other applicable settings and commissioning of the system.

When the installer settings are changed, the system will request to confirm. When confirmation is complete, the screen will shortly turn OFF and "busy" will be displayed for several seconds.

8.2 Basic configuration

8.2.1 Quick wizard: Language / time and date

#	Code	Description
[A.1]	N/A	Language
[1]	N/A	Time and date

8.2.2 Quick wizard: Standard

Backup heater configuration (only for *9W model)

The backup heater in a *9W model is adapted to be connected to most common European electricity grids. Besides hardware configuration, the grid type and the relay setting must be set on the user interface.

#	Code	Description
[A.2.1.5]	[5-0D]	BUH type: <ul style="list-style-type: none"> • 1 (1P,(1/1+2)): 6 kW 1~ 230 V (*9W) • 3 (3P,(1/1+2)): 6 kW 3~ 230 V (*9W) • 4 (3PN,(1/2)): 6 kW 3N~ 400 V (*9W) • 5 (3PN,(1/1+2)): 9 kW 3N~ 400 V (*9W)

Relay setting

Relay setting	Backup heater operation	
	If backup heater step 1 is active:	If backup heater step 2 is active:
1/1+2	Relay 1 ON	Relays 1+2 ON
1/2	Relay 1 ON	Relay 2 ON

Space heating/cooling settings

The system can heat up or cool down a space. Depending on the type of application, the space heating/cooling settings must be made accordingly.

#	Code	Description
[A.2.1.7]	[C-07]	Unit control method: <ul style="list-style-type: none"> • 0 (LWT control): Unit operation is decided based on the leaving water temperature regardless the actual room temperature and/or heating or cooling demand of the room. • 1 (Ext RT control): Unit operation is decided by the external thermostat or equivalent (e.g. heat pump convector). • 2 (RT control): Unit operation is decided based on the ambient temperature of the user interface.

8 Configuration

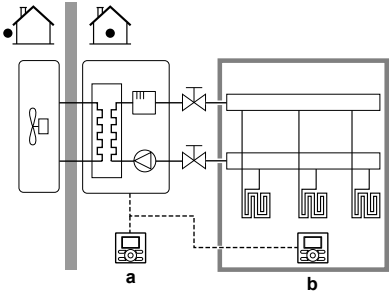
#	Code	Description
[A.2.1.B]	N/A	<p>Only if there are 2 user interfaces (1 installed in the room, 1 installed at the indoor unit):</p>  <ul style="list-style-type: none"> a: At unit b: In room as room thermostat <p>User interface location:</p> <ul style="list-style-type: none"> At unit: the other user interface is automatically set to In room and if RT control is selected act as room thermostat. In room (default): the other user interface is automatically set to At unit and if RT control is selected to act as room thermostat.

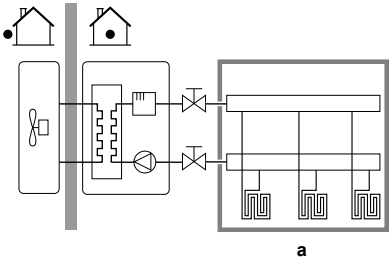
#	Code	Description
[A.2.1.8]	[7-02]	<p>The system can supply leaving water to up to 2 water temperature zones. During configuration, the number of water zones must be set.</p> <p>Number of LWT zones:</p> <ul style="list-style-type: none"> 0 (1 LWT zone)(default): Only 1 leaving water temperature zone. This zone is called the main leaving water temperature zone.  <ul style="list-style-type: none"> a: Main LWT zone <p style="text-align: right;">continued >></p>

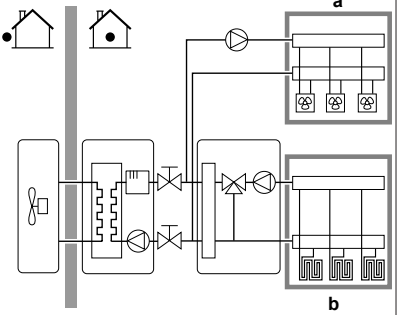
#	Code	Description
[A.2.1.8]	[7-02]	<p><< continuation</p> <ul style="list-style-type: none"> 1 (2 LWT zones): 2 leaving water temperature zones. The zone with the lowest leaving water temperature (in heating) is called the main leaving water temperature zone. The zone with the highest leaving water temperature (in heating) is called the additional leaving water temperature zone. In practice, the main leaving water temperature zone consists of the higher load heat emitters and a mixing station is installed to achieve the desired leaving water temperature.  <ul style="list-style-type: none"> a: Add LWT zone b: Main LWT zone

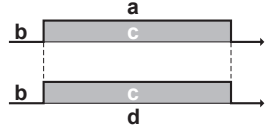
#	Code	Description
[A.2.1.9]	[F-0D]	<p>When the space heating/cooling control is OFF by the user interface, the pump is always OFF. When the space heating/cooling control is On, you can select the desired pump operation mode (only applicable during space heating/cooling)</p> <p>Pump operation mode:</p> <ul style="list-style-type: none"> 0 (Continuous): Continuous pump operation, regardless of thermo ON or OFF condition. Remark: continuous pump operation requires more energy than sample or request pump operation.  <ul style="list-style-type: none"> a: Space heating/cooling control (user interface) b: OFF c: On d: Pump operation <p style="text-align: right;">continued >></p>

#	Code	Description
[A.2.1.9]	[F-0D]	<p><< continuation</p> <ul style="list-style-type: none"> 1 (Sample)(default): The pump is ON. When there is heating or cooling demand as the leaving temperature has not reached the desired temperature yet. When thermo OFF condition occurs, the pump runs every 5 minutes to check the water temperature and demand heating or cooling if necessary. Remark: Sample is NOT available in extended room thermostat control or room thermostat control. <ul style="list-style-type: none"> a: Space heating/cooling control (user interface) b: OFF c: On d: LWT temperature e: Actual f: Desired g: Pump operation <p style="text-align: right;">continued >></p>

#	Code	Description
[A.2.1.9]	[F-0D]	<p><< continuation</p> <ul style="list-style-type: none"> 2 (Request): Pump operation based on request. Example: Using a room thermostat creates thermo ON/OFF condition. When there is no such demand, the pump is OFF. Remark: Request is NOT available in leaving water temperature control. <ul style="list-style-type: none"> a: Space heating/cooling control (user interface) b: OFF c: On d: Heating demand (by ext RT or RT) e: Pump operation

Following settings must be made accordingly.

#	Code	Description
[A.2.2.1]	[E-05]	<p>DHW operation:</p> <p>Can the system prepare domestic hot water?</p> <ul style="list-style-type: none"> 0 (No): NOT installed. Default for EHBH/X. 1 (Yes): Installed. Default for EHVH/X. Remark: For EHVH/X, the domestic hot water tank is by default installed. Do NOT change this setting.
[A.2.2.3]	[E-07]	<p>During domestic hot water preparation, the heat pump can be assisted by an electrical heater to ensure the domestic hot water preparation even for high desired tank temperatures.</p> <p>DHW tank type:</p> <ul style="list-style-type: none"> 0 (Type 1): Tank with booster heater installed at the side of the tank. Default for EHBH/X. 1 (Type 2): Default for EHVH/X. The backup heater will also be used for domestic hot water heating. <p>Range: 0~6. However, values 2~6 are not applicable for this setting. If the setting is set to 6, an error code will appear and the system will NOT operate.</p>
[A.2.2.A]	[D-02]	<p>The indoor unit offers the possibility to connect a field supplied domestic hot water pump (On/OFF type). Depending on the installation and configuration on the user interface, we distinguish its functionality.</p> <p>DHW pump:</p> <ul style="list-style-type: none"> 0 (No)(default): NOT installed. 1 (Secondary rtrn): Installed for instant hot water when water is tapped. The end-user sets the operation timing (weekly schedule time) of the domestic hot water pump when it should run. Control of this pump is possible through the indoor unit. 2 (Disinf. shunt): Installed for disinfection. It runs when the disinfection function of the domestic hot water tank is running. No further settings are needed. <p>See also illustrations below.</p>

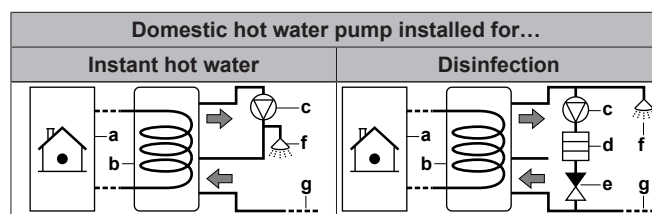

- a Indoor unit
- b Tank
- c Domestic hot water pump
- d Heater element
- e Non-return valve
- f Shower
- g Cold water

8.2.3 Quick wizard: Options

Domestic hot water settings

This chapter only applies to systems with a domestic hot water tank installed:

- EHBH/X: an optional domestic hot water tank is available,
- EHVH/X: a domestic hot water tank is standard incorporated into the indoor unit.

8 Configuration



INFORMATION

The correct domestic hot water default settings becomes only applicable when domestic hot water operation is activated ([E-05]=1).

Thermostats and external sensors



NOTICE

If an external room thermostat is used, the external room thermostat will control the room frost protection. However, the room frost protection is only possible if the leaving water temperature control on the unit's user interface is turned ON.

See ["5 Application guidelines" on page 11.](#)

#	Code	Description
[A.2.2.4]	[C-05]	<p>Contact type main</p> <p>In external room thermostat control, the contact type of the optional room thermostat or heat pump convector for the main leaving water temperature zone must be set. See "5 Application guidelines" on page 11.</p> <ul style="list-style-type: none"> 1 (Thermo ON/OFF): The connected external room thermostat or heat pump convector sends the heating or cooling demand by the same signal as it is connected to only 1 digital input (preserved for the main leaving water temperature zone) on the indoor unit (X2M/1). Select this value in case of a connection to the heat pump convector (FWXV). 2 (H/C request)(default): The connected external room thermostat sends separate heating and cooling demand and is therefore connected to the 2 digital input (preserved for the main leaving water temperature zone) on the indoor unit (X2M/1 and 2). Select this value in case of connection with the wired (EKRTWA) or wireless (EKRTR1) room thermostat.
[A.2.2.5]	[C-06]	<p>Contact type add.</p> <p>In external room thermostat control with 2 leaving water temperature zones, the type of the optional room thermostat for the additional leaving water temperature zone must be set. See "5 Application guidelines" on page 11.</p> <ul style="list-style-type: none"> 1 (Thermo ON/OFF): See Contact type main. Connected on the indoor unit (X2M/1a). 2 (H/C request)(default): See Contact type main. Connected on the indoor unit (X2M/1a and 2a).

#	Code	Description
[A.2.2.B]	[C-08]	<p>External sensor</p> <p>When an optional external ambient sensor is connected, the type of the sensor must be set. See "5 Application guidelines" on page 11.</p> <ul style="list-style-type: none"> 0 (No)(default): NOT installed. The thermistor in the user interface and in the outdoor unit are used for measurement. 1 (Outdoor sensor): Installed. The outdoor sensor will be used to measure the outdoor ambient temperature. Remark: For some functionality, the temperature sensor in the outdoor unit is still used. 2 (Room sensor): Installed. The temperature sensor in the user interface is NOT used anymore. Remark: This value has only meaning in room thermostat control.

Digital I/O PCB

Modification of these settings is only needed when the optional digital I/O PCB is installed. The digital I/O PCB has multiple functionality which need to be configured. See ["5 Application guidelines" on page 11.](#)

#	Code	Description
[A.2.2.6.1]	[C-02]	<p>Ext. backup heat src</p> <p>Indicates if the space heating is also performed by means of another heat source than the system.</p> <ul style="list-style-type: none"> 0 (No)(default): NOT installed. 1 (Bivalent): Installed. The auxiliary boiler (gasboiler, oil burner) will operate when the outdoor ambient temperature is low. During the bivalent operation, the heat pump is turned OFF. Set this value in case an auxiliary boiler is used. See "5 Application guidelines" on page 11.
[A.2.2.6.2]	[D-07]	<p>Solar kit</p> <p>Only applicable for EHBH/X. Indicates if the domestic hot water tank is also heated by thermal solar panels.</p> <ul style="list-style-type: none"> 0 (No)(default): NOT installed. 1 (Yes): Installed. The domestic hot water tank can –besides by the heat pump– also be heated by thermal solar panels. Set this value if thermal solar panels are installed. See "5 Application guidelines" on page 11.

#	Code	Description
[A.2.2.6.3]	[C-09]	Alarm output Indicates the logic of the alarm output on the digital I/O PCB during malfunctioning. <ul style="list-style-type: none"> 0 (Normally open)(default): The alarm output will be powered when an alarm occurs. By setting this value, a distinction is made between malfunctioning and detection of a power failure of the unit. 1 (Normally closed): The alarm output will NOT be powered when an alarm occurs.
[A.2.2.6.4]	[F-04]	Bottom plate heater Only applicable for EHBH/X11+16 and EHVH/X11+16. Indicates if an optional bottom plate heater is installed on the outdoor unit. The power of the bottom plate heater is in this case supplied by the indoor unit. <ul style="list-style-type: none"> 0 (No)(default): NOT installed. 1 (Yes): Installed. Remark: If this value is set, the output on the digital I/O PCB cannot be used for space heating/cooling output. See "5 Application guidelines" on page 11.

Alarm output logic

[C-09]	Alarm	No alarm	No power supply to unit
0 (default)	Closed output	Open output	Open output
1	Open output	Closed output	

Demand PCB

The demand PCB is used to enable the power consumption control by digital inputs. See ["5 Application guidelines" on page 11](#).

#	Code	Description
[A.2.2.7]	[D-04]	Demand PCB Only applicable for EHBH/X04+08 and EHVH/X04+08. Indicates if the optional demand PCB is installed. <ul style="list-style-type: none"> 0 (No)(default) 1 (Pwr consmp ctrl)

Energy metering

When energy metering is performed by the use of external power meters, configure the settings as described below. Select the pulse frequency output of each power meter in accordance with the power meter specifications. It is possible to connect (up to 2) power meters with different pulse frequencies. When only 1 or no power meter is used, select No to indicate the corresponding pulse input is NOT used.

#	Code	Description
[A.2.2.8]	[D-08]	Optional external kWh meter 1: <ul style="list-style-type: none"> 0 (No): NOT installed 1: Installed (0.1 pulse/kWh) 2: Installed (1 pulse/kWh) 3: Installed (10 pulse/kWh) 4: Installed (100 pulse/kWh) 5: Installed (1000 pulse/kWh)

#	Code	Description
[A.2.2.9]	[D-09]	Optional external kWh meter 2: <ul style="list-style-type: none"> 0 (No): NOT installed 1: Installed (0.1 pulse/kWh) 2: Installed (1 pulse/kWh) 3: Installed (10 pulse/kWh) 4: Installed (100 pulse/kWh) 5: Installed (1000 pulse/kWh)

8.2.4 Quick wizard: Capacities (energy metering)

The capacities of all electrical heaters must be set for the energy metering and/or power consumption control feature to work properly. When measuring the resistance value of each heater, you can set the exact heater capacity and this will lead to more accurate energy data.

#	Code	Description
[A.2.3.1]	[6-02]	Booster heater: Only applies to domestic hot water tanks with an internal booster heater (EKHW). The capacity of the booster heater at nominal voltage. Default: 0 kW. Range: 0~10 kW (in steps of 0.2 kW)
[A.2.3.2]	[6-03]	BUH: step 1: The capacity of the first step of the backup heater at nominal voltage. Default: 3 kW. Range: 0~10 kW (in steps of 0.2 kW)
[A.2.3.3]	[6-04]	BUH: step 2: Only applies to a two-step backup heater (*9W). The capacity difference between the second and first step of the backup heater at nominal voltage. Nominal value depends on the backup heater configuration: <ul style="list-style-type: none"> 3 kW, 1N~ 230 V: 0 kW 6 kW, 1N~ 230 V: 3 kW (6 kW-3 kW) 6 kW, 3~ 230 V: 3 kW (6 kW-3 kW) 6 kW, 3N~ 400 V: 3 kW (6 kW-3 kW) 9 kW, 3N~ 400 V: 6 kW (9 kW-3 kW) Range: 0~10 kW (in steps of 0.2 kW): <ul style="list-style-type: none"> *3V: default 0 kW *9W: default 6 kW
[A.2.3.6]	[6-07]	Bottom plate heater: Only applies to an optional bottom plate heater (EKBPPTH16A). The capacity of the optional bottom plate heater at nominal voltage. Default: 0 W. Range: 0~200 W (in steps of 10 W)

8.2.5 Space heating/cooling control

The basic required settings in order to configure the space heating/cooling of your system are described in this chapter. The weather-dependent installer settings define the parameters for the weather-dependent operation of the unit. When weather-dependent operation is active, the water temperature is determined automatically depending on the outdoor temperature. Low outdoor temperatures will result in warmer water and vice versa. During weather-dependent operation, the user has the possibility to shift up or down the target water temperature by a maximum of 5°C.

See the user reference guide and/or operation manual for more details about this function.

8 Configuration

Leaving water temperature: Main zone

#	Code	Description
[A.3.1.1.1]	N/A	<p>LWT setpoint mode:</p> <ul style="list-style-type: none"> Fixed (default) The desired leaving water temperature is: <ul style="list-style-type: none"> NOT weather-dependent (i.e. does NOT depend on the outdoor ambient temperature) fixed in time (i.e., NOT scheduled) Weather dep.: The desired leaving water temperature is: <ul style="list-style-type: none"> weather-dependent (i.e. depends on the outdoor ambient temperature) fixed in time (i.e., NOT scheduled) <p style="text-align: right;">continued >></p>

#	Code	Description
[A.3.1.1.1]	N/A	<p><< continuation</p> <ul style="list-style-type: none"> Fixed/scheduled: The desired leaving water temperature is: <ul style="list-style-type: none"> NOT weather-dependent (i.e., does NOT depend on the outdoor ambient temperature) according a schedule. The scheduled actions consists of desired shift actions, either preset or custom. <p>Remark: This value can only be set in leaving water temperature control.</p> WD/scheduled: The desired leaving water temperature is: <ul style="list-style-type: none"> weather-dependent (i.e., does depend on the outdoor ambient temperature) according a schedule. The scheduled actions consists of desired leaving water temperatures either preset or custom. <p>Remark: This value can only be set in leaving water temperature control.</p>

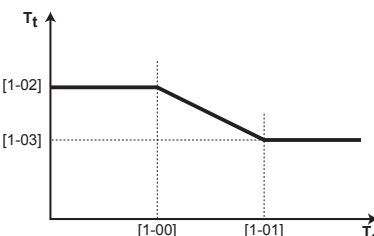
#	Code	Description
[7.7.1.1]	[1-00] [1-01] [1-02] [1-03]	<p>Set weather-dependent heating:</p>  <ul style="list-style-type: none"> T_t: Target leaving water temperature (main) T_a: Outdoor temperature <p style="text-align: right;">continued >></p>

#	Code	Description
[7.7.1.1]	[1-00] [1-01] [1-02] [1-03]	<p><< continuation</p> <ul style="list-style-type: none"> [1-00]: Low outdoor ambient temperature. $-40^{\circ}\text{C}\sim+5^{\circ}\text{C}$ (default: -10°C) [1-01]: High outdoor ambient temperature. $10^{\circ}\text{C}\sim25^{\circ}\text{C}$ (default: 15°C) [1-02]: Desired leaving water temperature when the outdoor temperature equals or drops below the low ambient temperature. $[9-01]\sim[9-00]^{\circ}\text{C}$ (default: 35°C). Note: This value should be higher than [1-03] as for low outdoor temperatures warmer water is required. [1-03]: Desired leaving water temperature when the outdoor temperature equals or rises above the high ambient temperature. $[9-01]\sim\min(45, [9-00])^{\circ}\text{C}$ (default: 25°C). Note: This value should be lower than [1-02] as for high outdoor temperatures less warm water is required.

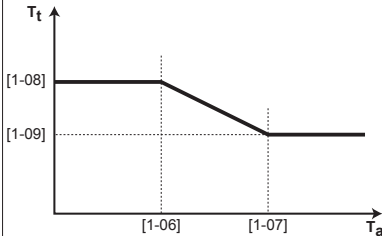
#	Code	Description
[7.7.1.2]	[1-06] [1-07] [1-08] [1-09]	<p>Set weather-dependent cooling:</p>  <ul style="list-style-type: none"> T_t: Target leaving water temperature (main) T_a: Outdoor temperature <p style="text-align: right;">continued >></p>

#	Code	Description
[7.7.1.2]	[1-06] [1-07] [1-08] [1-09]	<< continuation <ul style="list-style-type: none"> [1-06]: Low outdoor ambient temperature. 10°C~25°C (default: 20°C) [1-07]: High outdoor ambient temperature. 25°C~43°C (default: 35°C) [1-08]: Desired leaving water temperature when the outdoor temperature equals or drops below the low ambient temperature. [9-03]~[9-02]°C (default: 22°C). Note: This value should be higher than [1-09] as for low outdoor temperatures less cold water suffices. [1-09]: Desired leaving water temperature when the outdoor temperature equals or rises above the high ambient temperature. [9-03]~[9-02]°C (default: 18°C). Note: This value should be lower than [1-08] as for high outdoor temperatures colder water is required.

Leaving water temperature: Additional zone

Only applicable if 2 leaving water temperature zones are present.

#	Code	Description
[A.3.1.2.1]	N/A	LWT setpoint mode: <ul style="list-style-type: none"> Fixed (default): The desired leaving water temperature is: <ul style="list-style-type: none"> NOT weather-dependent (i.e. does NOT depend on the outdoor ambient temperature) fixed in time (i.e., NOT scheduled) Weather dep.: The desired leaving water temperature is: <ul style="list-style-type: none"> weather-dependent (i.e. depends on the outdoor ambient temperature) fixed in time (i.e., NOT scheduled) Fixed/scheduled: The desired leaving water temperature is: <ul style="list-style-type: none"> NOT weather-dependent (i.e., does NOT depend on the outdoor ambient temperature) according a schedule. The scheduled actions are On or OFF. Remark: This value can only be set in leaving water temperature control. WD/scheduled: The desired leaving water temperature is: <ul style="list-style-type: none"> weather-dependent (i.e., does depend on the outdoor ambient temperature) according a schedule. The scheduled actions are On or OFF. Remark: This value can only be set in leaving water temperature control.

#	Code	Description
[7.7.2.1]	[0-00] [0-01] [0-02] [0-03]	Set weather-dependent heating: <ul style="list-style-type: none"> T_i: Target leaving water temperature (main) T_a: Outdoor temperature continued >>

#	Code	Description
[7.7.2.1]	[0-00] [0-01] [0-02] [0-03]	<< continuation <ul style="list-style-type: none"> [0-03]: Low outdoor ambient temperature. -40°C~+5°C (default: -10°C) [0-02]: High outdoor ambient temperature. 10°C~25°C (default: 15°C) [0-01]: Desired leaving water temperature when the outdoor temperature equals or drops below the low ambient temperature. [9-05]~[9-06]°C (default: 45°C). Note: This value should be higher than [0-00] as for low outdoor temperatures warmer water is required. [0-00]: Desired leaving water temperature when the outdoor temperature equals or rises above the high ambient temperature. [9-05]~min(45, [9-06])°C (default: 35°C). Note: This value should be lower than [0-01] as for high outdoor temperatures less warm water is required.

#	Code	Description
[7.7.2.2]	[0-04] [0-05] [0-06] [0-07]	Set weather-dependent cooling: <ul style="list-style-type: none"> T_i: Target leaving water temperature (main) T_a: Outdoor temperature continued >>

8 Configuration

#	Code	Description
[7.7.2.2]	[0-04]	<< continuation
	[0-05]	<ul style="list-style-type: none"> [0-07]: Low outdoor ambient temperature. 10°C~25°C (default: 20°C)
	[0-06]	<ul style="list-style-type: none"> [0-06]: High outdoor ambient temperature. 25°C~43°C (default: 35°C)
	[0-07]	<ul style="list-style-type: none"> [0-05]: Desired leaving water temperature when the outdoor temperature equals or drops below the low ambient temperature. [9-07]~[9-08]°C (default: 12°C). Note: This value should be higher than [0-04] as for low outdoor temperatures less cold water suffices. [0-04]: Desired leaving water temperature when the outdoor temperature equals or rises above the high ambient temperature. [9-07]~[9-08]°C (default: 8°C). Note: This value should be lower than [0-05] as for high outdoor temperatures colder water is required.

Leaving water temperature: Delta T source

Temperature difference for entering and leaving water. The unit is designed to support under floor loops operation. The recommended leaving water temperature (set by the user interface) for under floor loops is 35°C. In such case, the unit will be controlled to realize a temperature difference of 5°C which means that the entering water to the unit is around 30°C. Depending on the installed application (radiators, heat pump convector, under floor loops) or situation, it can be possible to change the difference between entering and leaving water temperature. Note that the pump will regulate its flow to keep the Δt .

#	Code	Description
[A.3.1.3.1]	[9-09]	Heating: required temperature difference between entering and leaving water. Range: 3°C~10°C (in steps of 1°C; default value: 5°C).
[A.3.1.3.2]	[9-0A]	Cooling: required temperature difference between entering and leaving water. Range: 3°C~10°C (in steps of 1°C; default value: 5°C).

Leaving water temperature: Modulation

Only applicable in case of room thermostat control. When using the room thermostat functionality, the customer needs to set the desired room temperature. The unit will supply hot water to the heat emitters and the room will be heated. Additionally, also the desired leaving water temperature must be configured: when turning on the modulation, the desired leaving water temperature will be calculated automatically by the unit (based on the preset temperatures, if weather-dependent is selected, modulation will be done based on the desired weather-dependent temperatures); when turning off the modulation, you can set the desired leaving water temperature on the user interface. Moreover, with the modulation turned on, the desired leaving water temperature is lowered or raised in function of the desired room temperature and the difference between the actual and the desired room temperature. This results in:

- stable room temperatures exactly matching the desired temperature (higher comfort level)
- less On/OFF cycles (lower noise level, higher comfort and higher efficiency)

- water temperatures as low as possible to match the desired temperature (higher efficiency)

#	Code	Description
[A.3.1.1.5]	[8-05]	Modulated LWT: <ul style="list-style-type: none"> No (default): disabled. Note: The desired leaving water temperature needs to be set on the user interface. Yes: enabled. Note: The desired leaving water temperature can only be read out on the user interface

Leaving water temperature: Emitter type

Only applicable in case of room thermostat control. Depending on the system water volume and the heat emitters type, the heat up or cool down of a space can take longer. This setting can compensate for a slow or a quick heating/cooling system during the heat up/cool down cycle.

Note: The setting of the emitter type will influence the maximum modulation of the desired leaving water temperature and the possibility for usage of the automatic cooling/heating changeover based on the indoor ambient temperature.

Therefore it is important to set this correctly.

#	Code	Description
[A.3.1.1.7]	[9-0B]	Emitter type: Reaction time of the system: <ul style="list-style-type: none"> Quick Example: Small water volume and fan coils. Slow Example: Large water volume, floor heating loops.

8.2.6 Domestic hot water control

Only applicable in case an optional domestic hot water tank is installed.

Configuring the desired tank temperature

The domestic hot water can be prepared in 3 different ways. They differ from each other by the way the desired tank temperature is set and how the unit acts upon it.

#	Code	Description
[A.4.1]	[6-0D]	Domestic hot water Type: <ul style="list-style-type: none"> 0 (Reheat only): Only reheat operation is allowed. 1 (Reheat + sched.): The domestic hot water tank is heated according to a schedule and between the scheduled heatup cycles, reheat operation is allowed. 2 (Scheduled only): The domestic hot water tank can ONLY be heated according to a schedule.

See "8.3.2 Domestic hot water control: advanced" on page 60 for more details.

INFORMATION

There is a risk of space heating (cooling) capacity shortage/comfort problem (in case of frequent domestic hot water operation, frequent and long space heating/cooling interruption will happen) when selecting [6-0D]=0 ([A.4.1] Domestic hot water Type=Reheat only) in case of a domestic hot water tank without an internal booster heater.

Maximum DHW temperature setpoint

The maximum temperature that users can select for the domestic hot water. You can use this setting to limit the temperatures at the hot water taps.

**INFORMATION**

During disinfection of the domestic hot water tank, the DHW temperature can exceed this maximum temperature.

**INFORMATION**

Limit the maximum hot water temperature according to the applicable legislation.

#	Code	Description
[A.4.5]	[6-0E]	<p>Maximum setpoint</p> <p>The maximum temperature that users can select for the domestic hot water. You can use this setting to limit the temperature at the hot water taps.</p> <p>If</p> <ul style="list-style-type: none"> [E-07]≠1: 40°C~80°C (default: 60°C) (for EHBH/X in combination with EKHW) [E-07]=1: 40°C~60°C (default: 60°C) (only for EHVH/X) <p>The maximum temperature is NOT applicable during disinfection function. See disinfection function.</p>

8.2.7 Contact/helpdesk number

#	Code	Description
[6.3.2]	N/A	Number that users can call in case of problems.

8.3 Advanced configuration/ optimization**8.3.1 Space heating/cooling operation: advanced****Preset leaving water temperature**

You can define preset leaving water temperatures:

- economic (denotes the desired leaving water temperature which results in the lowest energy consumption)
- comfort (denotes the desired leaving water temperature which results in the highest energy consumption).

Preset values make it easy to use the same value in the schedule or to adjust the desired leaving water temperature according to the room temperature (see modulation). If you later want to change the value, you ONLY have to do it in one place. Depending on whether the desired leaving water temperature is weather dependent or NOT, the desired shift values or the absolute desired leaving water temperature should be specified.

**NOTICE**

The preset leaving water temperatures are ONLY applicable for the main zone, as the schedule for the additional zone consists of On/OFF actions.

**NOTICE**

Select preset leaving water temperatures in accordance with the design and selected heat emitters to ensure the balance between desired room and leaving water temperatures.

#	Code	Description
Preset leaving water temperature for the main leaving water temperature zone in case of NOT weather dependent		
[7.4.2.1]	[8-09]	Comfort (heating) [9-01]~[9-00] (default: 35°C)
[7.4.2.2]	[8-0A]	Eco (heating) [9-01]~[9-00] (default: 33°C)
[7.4.2.3]	[8-07]	Comfort (cooling) [9-03]~[9-02] (default: 18°C)
[7.4.2.4]	[8-08]	Eco (cooling) [9-03]~[9-02] (default: 20°C)
Preset leaving water temperature (shift value) for the main leaving water temperature zone in case of weather dependent		
[7.4.2.5]	N/A	Comfort (heating) -10°C~+10°C (default: 0°C)
[7.4.2.6]	N/A	Eco (heating) -10°C~+10°C (default: -2°C)
[7.4.2.7]	N/A	Comfort (cooling) -10°C~+10°C (default: 0°C)
[7.4.2.8]	N/A	Eco (cooling) -10°C~+10°C (default: 2°C)

Temperature ranges (leaving water temperatures)

The purpose of this setting is to prevent selecting a wrong (i.e. too hot or too cold) leaving water temperature. Therefore the available desired heating temperature range and desired cooling temperature range can be configured.

**NOTICE**

In case of a floor heating application it is important to limit the:

- maximum leaving water temperature at heating operation according to the specifications of the floor heating installation.
- the minimum leaving water temperature at cooling operation to 18~20°C to prevent condensation on the floor.

**NOTICE**

- When adjusting the leaving water temperature ranges, all desired leaving water temperatures are also adjusted to guarantee they are between the limits.
- Always balance between the desired leaving water temperature with the desired room temperature and/or the capacity (according to the design and selection of the heat emitters). The desired leaving water temperature is the result of several settings (preset values, shift values, weather dependent curves, modulation). As a result, too high or too low leaving water temperatures could occur which lead to overtemperatures or capacity shortage. By limiting the leaving water temperature range to adequate values (depending on the heat emitter), such situations can be avoided.

Example: Set the minimum leaving water temperature to 28°C to avoid NOT to be able to heat up the room: leaving water temperatures MUST be sufficiently higher than the room temperatures (in heating).

8 Configuration

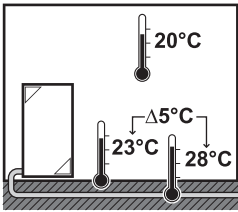

#	Code	Description
Leaving water temperature range for the main leaving water temperature zone (= the leaving water temperature zone with the lowest leaving water temperature in heating operation and the highest leaving water temperature in cooling operation)		
[A.3.1.1.2.2]	[9-00]	Maximum temp (heating) 37°C~depending on outdoor unit (default: 55°C)
[A.3.1.1.2.1]	[9-01]	Minimum temp (heating) 15°C~37°C (default: 25°C)
[A.3.1.1.2.4]	[9-02]	Maximum temp (cooling) 18°C~22°C (default: 22°C)
[A.3.1.1.2.3]	[9-03]	Minimum temp (cooling) 5°C~18°C (default: 5°C)
Leaving water temperature range for the additional leaving water temperature zone (= the leaving water temperature zone with the highest leaving water temperature in heating operation and the lowest leaving water temperature in cooling operation)		
[A.3.1.2.2.2]	[9-06]	Maximum temp (heating) 37°C~depending on outdoor unit (default: 55°C)
[A.3.1.2.2.1]	[9-05]	Minimum temp (heating) 15°C~37°C (default: 25°C)
[A.3.1.2.2.4]	[9-08]	Maximum temp (cooling) 18°C~22°C (default: 22°C)
[A.3.1.2.2.3]	[9-07]	Minimum temp (cooling) 5°C~18°C (default: 5°C)

Leaving water temperature overshoot temperature

This function defines how much the water temperature may rise above the desired leaving water temperature before the compressor stops. The compressor will startup again when the leaving water temperature drops below the desired leaving water temperature. This function is ONLY applicable in heating mode.

#	Code	Description
N/A	[9-04]	1°C~4°C (default: 1°C)

Leaving water temperature compensation around 0°C

In heating operation, the desired leaving water temperature is locally increased around an outdoor temperature of 0°C. This compensation can be selected when using an absolute or a weather dependent desired temperature (see illustration below). Use this setting to compensate for possible heat losses of the building due to the evaporation of melted ice or snow (e.g. in cold region countries).

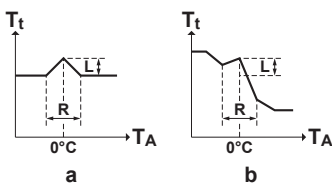

a Absolute desired LWT
b Weather dependent desired LWT

#	Code	Description
N/A	[D-03]	<ul style="list-style-type: none"> 0 (disabled) (default) 1 (enabled) L=2°C, R=4°C (-2°C<T_A<2°C) 2 (enabled) L=4°C, R=4°C (-2°C<T_A<2°C) 3 (enabled) L=2°C, R=8°C (-4°C<T_A<4°C) 4 (enabled) L=4°C, R=8°C (-4°C<T_A<4°C)

Leaving water temperature maximum modulation

ONLY applicable in room thermostat control and when modulation is enabled. The maximum modulation (=variance) on the desired leaving water temperature decided on the difference between the actual and desired room temperature, e.g. 3°C modulation means the desired leaving water temperature can be increased or lowered by 3°C. Increasing the modulation results in better performance (less On/OFF, faster heat up), but note that depending on the heat emitter, there MUST ALWAYS be a balance (refer to the design and selection of the heat emitters) between the desired leaving water temperature and the desired room temperature.

#	Code	Description
N/A	[8-06]	0°C~10°C (default: 3°C)

Weather dependent cooling allowance

ONLY applicable for EHBX and EHVX. It is possible to disable weather dependent cooling, meaning the desired leaving water temperature in cooling operation does NOT depend on the outdoor ambient temperature and this regardless whether weather dependent is selected or NOT. Both for the main leaving water temperature zone as for the additional leaving water temperature zone, this can be set separately.

#	Code	Description
N/A	[1-04]	Weather dependent cooling of the main leaving water temperature zone is... <ul style="list-style-type: none"> 0 (disabled) 1 (enabled) (default)
N/A	[1-05]	Weather dependent cooling of the additional leaving water temperature zone is... <ul style="list-style-type: none"> 0 (disabled) 1 (enabled) (default)

Temperature ranges (room temperature)

ONLY applicable in room thermostat control. In order to save energy by preventing overheating or undercooling the room, you can limit the range of the room temperature, both for heating and/or cooling.



NOTICE

When adjusting the room temperature ranges, all desired room temperatures are also adjusted to guarantee they are between the limits.

#	Code	Description
Room temp. range		
[A.3.2.1.2]	[3-06]	Maximum temp (heating) 18°C~30°C (default: 30°C)
[A.3.2.1.1]	[3-07]	Minimum temp (heating) 12°C~18°C (default: 12°C)
[A.3.2.1.4]	[3-08]	Maximum temp (cooling) 25°C~35°C (default: 35°C)

#	Code	Description
[A.3.2.1.3]	[3-09]	Minimum temp (cooling) 15°C~25°C (default: 15°C)

Room temperature step

ONLY applicable in room thermostat control and when the temperature is displayed in °C.

#	Code	Description
[A.3.2.4]	N/A	Room temp. step <ul style="list-style-type: none"> 1°C (default). The desired room temperature on the user interface is settable per 1°C. 0.5°C. The desired room temperature on the user interface is settable per 0.5°C. The actual room temperature is displayed with an accuracy of 0.1°C.

Room temperature hysteresis

ONLY applicable in case of room thermostat control. The hysteresis band around the desired room temperature is settable. It is recommended NOT to change the room temperature hysteresis as it is set for an optimal use of the system.

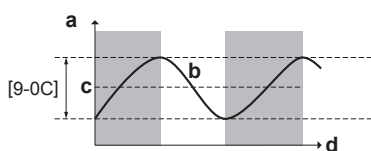

- a Room temperature
b Actual room temperature
c Desired room temperature
d Time

#	Code	Description
N/A	[9-0C]	1°C~6°C (default: 1°C)

Room temperature offset

ONLY applicable in case of room thermostat control. You can calibrate the (external) room temperature sensor. It is possible to give an offset to the room thermistor value measured by the user interface or by the external room sensor. The settings can be used to compensate for situations where the user interface or external room sensor CANNOT be installed on the ideal installation location (see installation manual and/or installer reference guide).

#	Code	Description
Room temp. offset: Offset on the actual room temperature measured on the user interface sensor.		
[A.3.2.2]	[2-0A]	-5°C~5°C, step 0.5°C (default: 0°C)
Ext. room sensor offset: ONLY applicable if the external room sensor option is installed and configured (see [C-08])		
[A.3.2.3]	[2-09]	-5°C~5°C, step 0.5°C (default: 0°C)

Room frost protection

ONLY applicable in case of room thermostat control. When the actual room temperature would drop below the room frost temperature, the unit will supply leaving water (in heating operation mode) to the heat emitters to heat up the room again.



NOTICE

Even if the room thermostat control is OFF on the user interface, room frost protection remains active.



NOTICE

If Emergency is set to Manual ([A.5.1.2]=0), and the unit is triggered to start emergency operation, the user interface will ask confirmation before starting. Room frost protection is active even if the user does NOT confirm emergency operation.



INFORMATION

If an U4 error occurs, room frost protection is NOT guaranteed.



INFORMATION

If an U5 error occurs:

- when 1 user interface is connected, room frost protection is NOT guaranteed,
- when 2 user interfaces are connected and the second user interface used for room temperature control is disconnected (due to miswiring, damage of the cable), then room frost protection is NOT guaranteed.

#	Code	Description
N/A	[2-06]	Room frost protection <ul style="list-style-type: none"> 0: disabled (default) 1: enabled
N/A	[2-05]	Room antifrost temperature 4°C~16°C (default: 12°C)

Shut-off valve

The following is only applicable in case of 2 leaving water temperature zones. In case of 1 leaving water temperature zone, connect the shut-off valve to the heating/cooling output.

The shut-off valve, which is in the main leaving water temperature zone, output is configurable.



INFORMATION

During defrost operation, the shut-off valve is ALWAYS opened.

Thermo On/OFF: the valve closes, depending on [F-0B] when there is no heating demand from the main zone. Enable this setting to:

- avoid leaving water supply to the heat emitters in the main LWT zone (through the mixing valve station) when there is request from the additional LWT zone.
- activate the On/OFF pump of the mixing valve station ONLY when there is demand. See "5 Application guidelines" on page 11.

#	Code	Description
[A.3.1.1.6.1]	[F-0B]	The shut-off valve: <ul style="list-style-type: none"> 0 (No)(default): is NOT influenced by heating or cooling demand. 1 (Yes): closes when there is NO heating or cooling demand.



INFORMATION

The setting [F-0B] is only valid when there is a thermostat or external room thermostat request setting (NOT in case of leaving water temperature setting).

Cooling: ONLY applicable for EHBX and EHVX. The shut-off valve closes, depending on [F-0C] when the unit is running in cooling operation mode. Enable this setting to avoid cold leaving water through the heat emitter and the forming of condensation (e.g. under floor heating loops or radiators).

8 Configuration

#	Code	Description
[A.3.1.1.6.2]	[F-0C]	The shut-off valve: <ul style="list-style-type: none"> 0 (No): is NOT influenced by changing the space operation mode to cooling. 1 (Yes)(default): closes when the space operation mode is cooling.

Operation range

Depending on the average outdoor temperature, the operation of the unit in space heating or space cooling is prohibited.

Space heating OFF temp: When the averaged outdoor temperature raises above this value, space heating is turned OFF to avoid overheating.

#	Code	Description
[A.3.3.1]	[4-02]	<ul style="list-style-type: none"> EHBH/X04+08 and EHVH/X04+08: 14°C~25°C (default: 25°C) <p>Remark: In the menu structure, the highest value is 25°C, but in the overview settings you can set this value up to 35°C!</p> <ul style="list-style-type: none"> EHBH/X11+16 and EHVH/X11+16: 14°C~35°C (default: 35°C) <p>The same setting is also used in automatic heating/cooling changeover.</p>

Space cooling On temp: ONLY applicable for EHBX and EHVX. When the averaged outdoor temperature drops below this value, space cooling is turned OFF.

#	Code	Description
[A.3.3.2]	[F-01]	10°C~35°C (default: 20°C) The same setting is also used in automatic heating/cooling changeover.

Automatic heating/cooling changeover

ONLY applicable for EHBX and EHVX. The end-user sets the desired operation mode on the user interface: Heating, Cooling or Automatic (see also operation manual/user reference guide). When Automatic is selected, the changing of the operation mode is based on:

- Monthly allowance for heating and/or cooling: the end-user indicates on a monthly base which operation is allowed ([7.5]: both heating/cooling or heating ONLY or cooling ONLY). If the allowed operation mode changes to cooling ONLY, the operation mode changes to cooling. If the allowed operation mode changes to heating ONLY, the operation mode changes to heating.
- Averaged outdoor temperature: the operation mode will be changed in order to ALWAYS be within range determined by the space heating OFF temperature for heating and the space cooling On temperature for cooling. If the outdoor temperature drops, the operation mode switches to heating and vice versa. Note that the outdoor temperature will be time-averaged (see "8 Configuration" on page 47).

When the outdoor temperature is between the space cooling On and the space heating OFF temperature, the operation mode remains unchanged unless the system is configured in room thermostat control with one leaving water temperature zone and quick heat emitters. In that case, the operation mode will change based on:

- Measured indoor temperature: besides the heating and the cooling desired room temperature, the installer sets a hysteresis value (e.g. when in heating, this value is related to the desired cooling temperature) and an offset value (e.g. when in heating, this value is related to the desired heating temperature). Example: the desired room temperature in heating is 22°C and in cooling 24°C, with a hysteresis value of 1°C and an offset of 4°C. Changeover from heating to cooling will occur when the room

temperature rises above the maximum of the desired cooling temperature added by the hysteresis value (thus 25°C) and the desired heating temperature added by the offset value (thus 26°C). Oppositely, changeover from cooling to heating will occur when the room temperature drops below the minimum of the desired heating temperature subtracted by the hysteresis value (thus 21°C) and the desired cooling temperature subtracted by the offset value (thus 20°C).

- Guard timer to prevent too frequent changing from heating to cooling and vice versa.

Changeover settings related to the outdoor temperature (ONLY when automatic is selected):

#	Code	Description
[A.3.3.1]	[4-02]	Space heating OFF temp. If the outdoor temperature rises above this value, the operation mode will change to cooling: <ul style="list-style-type: none"> EHBH/X04+08 and EHVH/X04+08: 14°C~25°C (default: 25°C) <p>Remark: In the menu structure, the highest value is 25°C, but in the overview settings you can set this value up to 35°C!</p> <ul style="list-style-type: none"> EHBH/X11+16 and EHVH/X11+16: 14°C~35°C (default: 35°C)
[A.3.3.2]	[F-01]	Space cooling On temp. If the outdoor temperature drops below this value, the operation mode will change to heating: Range: 10°C~35°C (default: 20°C)

Changeover settings related to the indoor temperature. ONLY applicable when Automatic is selected and the system is configured in room thermostat control with 1 leaving water temperature zone and quick heat emitters.

N/A	[4-0B]	Hysteresis: Ensures that changeover is ONLY done when necessary. Example: the space operation mode ONLY changes from cooling to heating when the room temperature drops below the desired heating temperature subtracted by the hysteresis. Range: 1°C~10°C, step 0.5°C (default: 1°C)
N/A	[4-0D]	Offset: Ensures that the active desired room temperature can be reached. Example: if heating to cooling changeover would occur below the desired room temperature in heating, this desired room temperature could never be reached. Range: 1°C~10°C, step 0.5°C (default: 3°C)

8.3.2 Domestic hot water control: advanced

Preset tank temperatures

Only applicable when domestic hot water preparation is scheduled or scheduled + reheat.

You can define preset tank temperatures:

- storage economic
- storage comfort
- reheat

Preset values make it easy to use the same value in the schedule. If you later want to change the value, you only have to do it in 1 place (see also operation manual and/or user reference guide).

Storage comfort: When programming the schedule, you can make use of the tank temperatures set as preset values. The tank will then heat up until these setpoint temperatures have been reached. Additionally, a storage stop can be programmed. This feature puts a stop to tank heating even if the setpoint has NOT been reached. Only program a storage stop when tank heating is absolutely undesirable.

#	Code	Description
[7.4.3.1]	[6-0A]	30°C~[6-0E]°C (default: 60°C)

Storage eco: The storage economic temperature denotes the lower desired tank temperature. It is the desired temperature when a storage economic action is scheduled (preferably during day).

#	Code	Description
[7.4.3.2]	[6-0B]	30°C~min(50, [6-0E])°C (default: 45°C)

Reheat: The desired reheat tank temperature is used:

- in reheat mode or scheduled + reheat mode: The guaranteed minimum tank temperature is set by T_{HP_OFF} [6-08], which is either [6-0C] or the weather dependent setpoint, minus the reheat hysteresis. If the tank temperature drops below this value, the tank is heated up.

#	Code	Description
[7.4.3.3]	[6-0C]	30°C~min(50, [6-0E])°C (default: 45°C)

Weather dependent

The weather dependent installer settings define the parameters for the weather dependent operation of the unit. When weather dependent operation is active the desired tank temperature is determined automatically depending on the averaged outdoor temperature: low outdoor temperatures will result in higher desired tank temperatures as the cold water tap is colder and vice versa. In case of scheduled or scheduled+reheat domestic hot water preparation, the storage comfort temperature is weather dependent (according to the weather dependent curve), the storage economic and reheat temperature are NOT weather dependent. In case of reheat only domestic hot water preparation, the desired tank temperature is weather dependent (according to the weather dependent curve). During weather dependent operation, the end-user cannot adjust the desired tank temperature on the user interface.

#	Code	Description
[A.4.6]	N/A	<p>Weather dependent desired tank temperature is:</p> <ul style="list-style-type: none"> Fixed (default): disabled. All desired tank temperature are NOT weather dependent. Weather dep.: enabled. In scheduled or scheduled+reheat mode, the storage comfort temperature is weather dependent. Storage economic and reheat temperatures are NOT weather dependent. In reheat mode, the desired tank temperature is weather dependent. <p>Note: When the displayed tank temperature is weather dependent, it cannot be adjusted on the user interface.</p>

#	Code	Description
[A.4.7]	[0-0E] [0-0D] [0-0C] [0-0B]	<p>Weather-dependent curve</p> <ul style="list-style-type: none"> T_{DHW}: The desired tank temperature. T_a: The (averaged) outdoor ambient temperature [0-0E]: low outdoor ambient temperature: -40°C~5°C (default: -10°C) [0-0D]: high outdoor ambient temperature: 10°C~25°C (default: 15°C) [0-0C]: desired tank temperature when the outdoor temperature equals or drops below the low ambient temperature: 45°C~[6-0E]°C (default: 60°C) [0-0B]: desired tank temperature when the outdoor temperature equals or rises above the high ambient temperature: 35°C~[6-0E]°C (default: 50°C)

8 Configuration

Booster heater and heat pump operation

For systems with separate domestic hot water tank (only for EHBH/X)

#	Code	Description
N/A	[4-03]	<p>Defines the operation permission of the booster heater depending on ambient, domestic hot water temperature or operation mode of heat pump. This setting is only applicable in reheat mode for applications with separate domestic hot water tank.</p> <ul style="list-style-type: none"> 0: Booster heater operation is NOT allowed except for "Disinfection function" and "Powerful domestic water heating". Only use this in case the capacity of the heat pump can cover the heating requirements of the house and domestic hot water over the complete heating season. If the outdoor temperature is below setting [5-03] and [5-02]=1, the domestic hot water will not be heated. The domestic hot water temperature can be maximum the heat pump OFF temperature. 1: Booster heater operation is allowed when required. 2: The booster heater is allowed outside the operation range of the heat pump for domestic hot water operation. Booster heater operation is only allowed if: <ul style="list-style-type: none"> Ambient temperature is out of the operating range: $T_a < [5-03]$ or $T_a > 35^\circ\text{C}$ Domestic hot water temperature is 2°C lower than the heat pump OFF temperature. <p style="text-align: right;">continued >></p>

#	Code	Description
N/A	[4-03]	<p><< continuation</p> <p>The booster heater will be allowed to operate when $T_a < [5-03]$ depends of the status of [5-02].</p> <p>If bivalent operation is enabled and permission signal for auxiliary boiler is ON, the booster heater will be restricted even when $T_a < [5-03]$. See [C-02].</p> <ul style="list-style-type: none"> 3 (default): The booster heater is allowed when the heat pump is NOT active in domestic hot water operation. Same as setting 1, but simultaneous heat pump domestic hot water operation and booster heater operation is not allowed. <p>When setting [4-03]=1/2/3, the booster heater operation can still be restricted by the booster heater allowance schedule.</p>

#	Code	Description
N/A	[7-00]	<p>Overshoot temperature. Temperature difference above the domestic hot water set point temperature before the booster heater is turned OFF. The domestic hot water tank temperature will increase with [7-00] above selected temperature set point.</p> <p>Range: $0^\circ\text{C} \sim 4^\circ\text{C}$ (default: 0°C)</p>
N/A	[7-01]	<p>Hysteresis. Temperature difference between booster heater ON and booster heater OFF temperature. The minimum hysteresis temperature is 2°C.</p> <p>Range: $2^\circ\text{C} \sim 40^\circ\text{C}$ (default: 2°C)</p>
N/A	[6-00]	<p>The temperature difference determining the heat pump ON temperature.</p> <p>Range: $2^\circ\text{C} \sim 20^\circ\text{C}$ (default: 2°C)</p>
N/A	[6-01]	<p>The temperature difference determining the heat pump OFF temperature.</p> <p>Range: $0^\circ\text{C} \sim 10^\circ\text{C}$ (default: 2°C)</p>

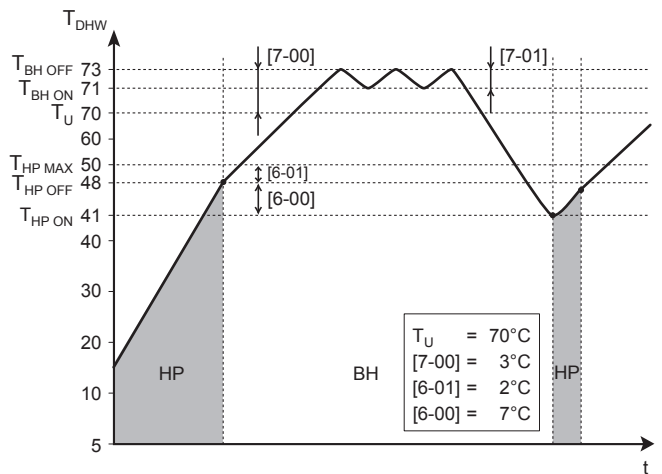

BH Booster heater

HP Heat pump. If heating up time by the heat pump takes too long, auxiliary heating by the booster heater can take place

$T_{BH\ OFF}$ Booster heater OFF temperature ($T_U + [7-00]$)

$T_{BH\ ON}$ Booster heater ON temperature ($T_{BH\ OFF} - [7-01]$)

$T_{HP\ MAX}$ Maximum heat pump temperature at sensor in domestic hot water tank

$T_{HP\ OFF}$ Heat pump OFF temperature ($T_{HP\ MAX} - [6-01]$)

$T_{HP\ ON}$ Heat pump ON temperature ($T_{HP\ OFF} - [6-00]$)

T_{DHW} Domestic hot water temperature

T_U User set point temperature (as set on the user interface)

t Time

Timers for simultaneous request space and domestic hot water operation

#	Code	Description
N/A	[8-00]	Do not change. (default: 1)
N/A	[8-01]	<p>Maximum running time for domestic hot water operation. Domestic hot water heating stops even when the target domestic hot water temperature is NOT reached. The actual maximum running time also depends on setting [8-04].</p> <ul style="list-style-type: none"> When system layout = Room thermostat control: This preset value is only taken into account if there is a request for space heating or cooling. If there is NO request for space heating/cooling, the tank is heated until the setpoint has been reached. When system layout ≠ Room thermostat control: This preset value is always taken into account. <p>Range: 5~95 minutes (default: 30)</p>
N/A	[8-02]	<p>Anti-recycling time.</p> <p>Minimum time between two cycles for domestic hot water. The actual anti-recycling time also depends on setting [8-04].</p> <p>Range: 0~10 hours (default: 3) (step: 1/2 hour) (only for EHBH/X).</p> <p>Range: 0~10 hours (default: 0.5) (step: 1/2 hour) (only for EHVH/X).</p> <p>Remark: The minimum time is 1/2 hour even when the selected value is 0.</p>
N/A	[8-03]	<p>Booster heater delay timer.</p> <p>Only for EKHW</p> <p>Start-up delay time for the booster heater when domestic hot water mode is active.</p> <ul style="list-style-type: none"> When domestic hot water mode is NOT active, the delay time is 20 minutes. The delay time starts from booster heater ON temperature. By adapting the booster heater delay time versus the maximum running time, you can find an optimal balance between the energy efficiency and the heat up time. If the booster heater delay time is set too high, it might take a long time before the domestic hot water reaches its set temperature. The setting [8-03] is only meaningful if setting [4-03]=1. Setting [4-03]=0/2/3 limits the booster heater automatically in relation to heat pump operation time in domestic water heating mode. Make sure that [8-03] is always in relation with the maximum running time [8-01]. <p>Range: 20~95 minutes (default: 50).</p>
N/A	[8-04]	<p>Additional running time for the maximum running time depending on the outdoor temperature [4-02] or [F-01].</p> <p>Range: 0~95 minutes (default: 95).</p>

[8-02]: Anti-recycling time

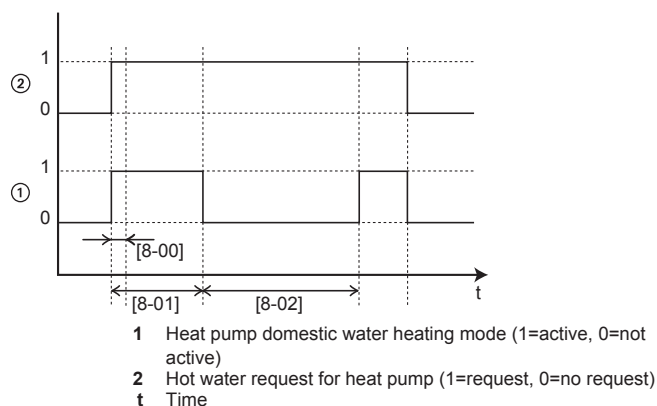

[8-03]: Booster heater delay timer

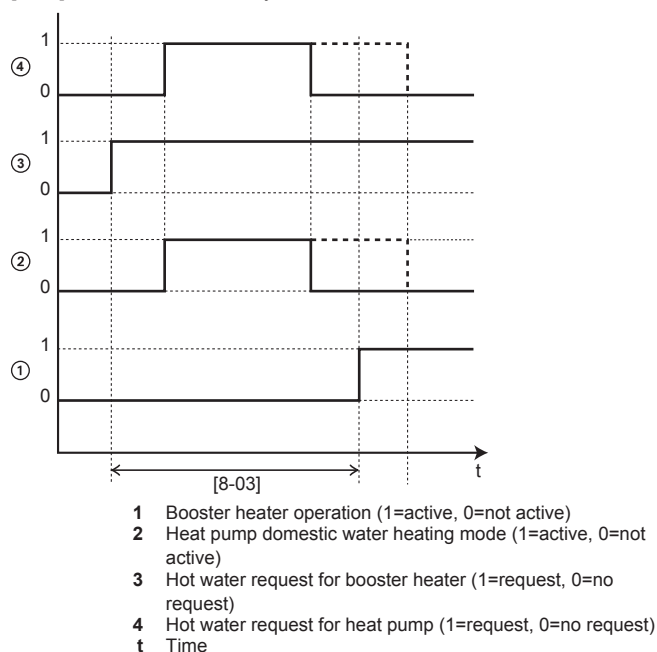

[8-04]: Additional running time at [4-02]/[F-01]

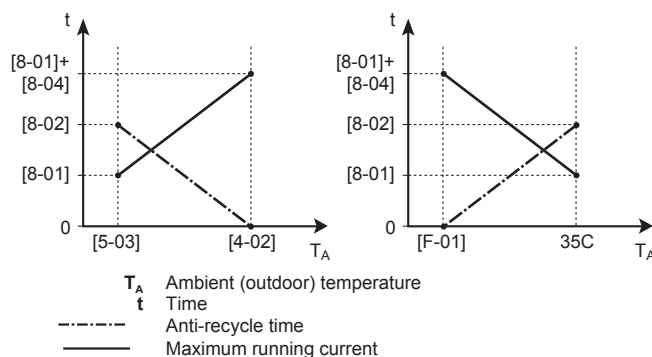

Disinfection

Applies only to installations with a domestic hot water tank.

The disinfection function disinfects the domestic hot water tank by periodically heating the domestic hot water to a specific temperature.



CAUTION

The disinfection function settings **MUST** be configured by the installer according to the applicable legislation.

8 Configuration

#	Code	Description
[A.4.4.2]	[2-00]	Operation day: <ul style="list-style-type: none"> ▪ 0: Each day ▪ 1: Monday ▪ 2: Tuesday ▪ 3: Wednesday ▪ 4: Thursday ▪ 5: Friday ▪ 6: Saturday ▪ 7: Sunday
[A.4.4.1]	[2-01]	Disinfection <ul style="list-style-type: none"> ▪ 0: No ▪ 1: Yes
[A.4.4.3]	[2-02]	Start time: 00~23:00, step: 1:00.
[A.4.4.4]	[2-03]	Temperature target: <ul style="list-style-type: none"> ▪ With booster heater: 55°C~80°C, default: 70°C. ▪ Without booster heater: 60°C (fixed).
[A.4.4.5]	[2-04]	Duration: <ul style="list-style-type: none"> ▪ With booster heater: 5~60 minutes, default: 10 minutes. ▪ Without booster heater: 40~60 minutes, default: 40 minutes.

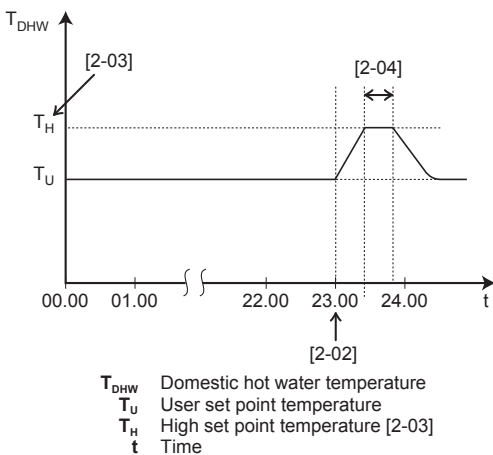

WARNING

Be aware that the domestic hot water temperature at the hot water tap will be equal to the value selected in field setting [2-03] after a disinfection operation.

When the high domestic hot water temperature can be a potential risk for human injuries, a mixing valve (field supply) shall be installed at the hot water outlet connection of the domestic hot water tank. This mixing valve shall secure that the hot water temperature at the hot water tap never rise above a set maximum value. This maximum allowable hot water temperature shall be selected according to the applicable legislation.



CAUTION

Be sure that the disinfection function start time [A.4.4.3] with defined duration [A.4.4.5] is NOT interrupted by possible domestic hot water demand.



CAUTION

The booster heater permission schedule is used to restrict or allow booster heater operation based on a weekly program. Advice: In order to avoid unsuccessful disinfection function, at least allow the booster heater (by the weekly program) for minimum 4 hours starting from the scheduled start-up of disinfection. If the booster heater is restricted during disinfection, this function will NOT be successful and the applicable warning AH will be generated.



INFORMATION

In case of error code AH and no interruption of the disinfection function occurred due to domestic hot water tapping, following actions are recommended:

- When the Domestic hot water > Type > Reheat or Reheat + sched. is selected, it is recommended to program the start-up of the disinfection function at least 4 hours later than the last expected large hot water tapping. This start-up can be set by installer settings (disinfection function).
- When the Domestic hot water > Type > Scheduled only is selected, it is recommended to program a Storage eco 3 hours before the scheduled start-up of the disinfection function to preheat the tank.



INFORMATION

Disinfection function is restarted in case the domestic hot water temperature drops 5°C below the disinfection target temperature within the duration time.



INFORMATION

An AH error occurs if you do the following during disinfection:

- Set the user permission level to Installer.
- Go to the DHW tank temperature home page (Tank).
- Press \downarrow to interrupt the disinfection.

8.3.3 Heat source settings

Backup heater

For systems without domestic hot water tank or with separate domestic hot water tank (only for EHBH/X)

Backup heater operation mode: defines when backup heater operation is enabled or disabled. This setting is only overruled when backup heating is required during defrost operation or malfunctioning of the outdoor unit (when [A.5.1.2] is enabled).

For systems with an integrated domestic hot water tank (only for EHVH/X)

Backup heater operation mode: defines when backup heater operation is disabled or only allowed during domestic hot water operation. This setting is only overruled when backup heating is required during defrost operation or malfunctioning of the outdoor unit (when [A.5.1.2] is enabled).

#	Code	Description
[A.5.1.1]	[4-00]	Backup heater operation: <ul style="list-style-type: none"> ▪ 0: Disabled ▪ 1 (default): Enabled

#	Code	Description
[A.5.1.3]	[4-07]	Defines whether backup heater second step is: <ul style="list-style-type: none"> 1: Allowed 0: NOT allowed In this way it is possible to limit the backup heater capacity.
N/A	[5-00]	Is backup heater operation allowed above equilibrium temperature during space heating operation? <ul style="list-style-type: none"> 1: NOT allowed 0: Allowed
[A.5.1.4]	[5-01]	Equilibrium temperature. Outdoor temperature below which operation of the backup heater is allowed. Range: $-15^{\circ}\text{C}\sim 35^{\circ}\text{C}$ (default: 0°C) (step: 1°C)

i INFORMATION

Only for systems with integrated domestic hot water tank: If backup heater operation during space heating needs to be limited but can be allowed for domestic hot water operation, then put [4-00] on 1, [5-00] on 1, and [5-01] on -15°C .

i INFORMATION

Only for systems with integrated domestic hot water tank: If the storage temperature set point is higher than 50°C , Daikin recommends NOT to disable the backup heater second step because it will have a big impact on the required time for the unit to heat up the domestic hot water tank.

Auto emergency

When the heat pump fails to operate the backup heater can serve as an emergency heater and either automatically or non-automatically take over the heat load. When auto emergency is set to Automatic and a heat pump failure occurs, the backup heater will automatically take over the heat load. When a heat pump failure occurs and auto emergency is set to Manual the domestic hot water and space heating operations will stop and need to be recovered manually. The user interface will then ask you to confirm whether the backup heater can take over the heat load or not. When the heat pump fails, **i** will appear on the user interface. If the house is unattended for longer periods, we recommend that setting [A.5.1.2] Emergency shall be set to Automatic.

#	Code	Description
[A.5.1.2]	N/A	Defines whether in an emergency situation the backup heater is allowed to automatically take over the entire heat load or whether manual confirmation is required. <ul style="list-style-type: none"> 0: Manual (default) 1: Automatic

i INFORMATION

The auto emergency setting can be set in the menu structure of the user interface only.

i INFORMATION

If a heat pump failure occurs and [A.5.1.2] is set to Manual, the room frost protection function, the underfloor heating screed dryout function, and the water pipe antifreeze function will remain active even if the user does NOT confirm emergency operation.

Bivalent

Applies only to installations with an auxiliary boiler (alternating operation, parallel connected). The purpose of this function is to determine — based on the outdoor temperature (possibility 1) or on energy prices (possibility 2) — which heating source can/will provide the space heating, either the indoor unit or an auxiliary boiler.

The field setting "bivalent operation" applies only the indoor unit space heating operation and the permission signal for the auxiliary boiler.

Possibility 1

The installer can set an equilibrium temperature below which the boiler will always operate when electric prices (High, Medium, Low) are "0" in the menu structure.

! NOTICE

Do NOT use overview settings!

When the "bivalent operation" function is enabled, the indoor unit will stop automatically in space heating operation when the outdoor temperature drops below "bivalent ON temperature" and the permission signal for the auxiliary boiler becomes active.

When the bivalent operation function is disabled, the space heating by indoor unit is possible at all outdoor temperatures (see operation ranges) and permission signal for auxiliary boiler is ALWAYS deactivated.

- [C-03] Bivalent ON temperature: defines the outdoor temperature below which the permission signal for the auxiliary boiler will be active (closed, KCR on EKR1HB) and space heating by indoor unit will be stopped.
- [C-04] Bivalent hysteresis: defines the temperature difference between bivalent ON temperature and bivalent OFF temperature.

Permission signal X1–X2 (EKR1HB)

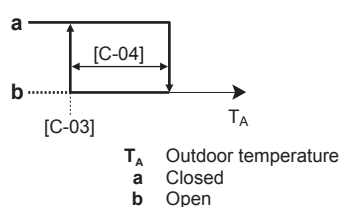

#	Code	Description
N/A	[C-03]	Range: $-25^{\circ}\text{C}\sim 25^{\circ}\text{C}$ (default: 0°C) (step: 1°C)
N/A	[C-04]	Range: $2^{\circ}\text{C}\sim 10^{\circ}\text{C}$ (default: 3°C) (step: 1°C)

Possibility 2

The installer can set an equilibrium temperature based on energy prices when energy prices [7.4.5] and [7.4.6] are changed in the menu structure.

#	Code	Description
[7.4.5.1]	N/A	What is the high electricity price?
[7.4.5.2]	N/A	What is the medium electricity price?

8 Configuration

#	Code	Description
[7.4.5.3]	N/A	What is the low electricity price?
[7.4.6]	N/A	What is the fuel price?

NOTICE

Do NOT use overview settings!

Depending on the energy prices, this equilibrium point T changes between a range of [C-04].

When T_A reaches the T_{eq} point, then the bivalent heat source permission will be active. To prevent too much switching, there is a hysteresis of 3°C.

- [C-03] ON temperature. Below this temperature, bivalent will always be ON. The equilibrium point is ignored.
- [C-04] Operation range between which the equilibrium point is calculated.

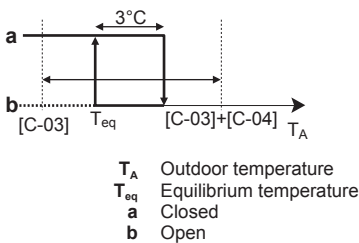

#	Code	Description
N/A	[C-03]	Range: -25°C~25°C (default: 0°C) (step: 1°C)
N/A	[C-04]	Range: 2°C~10°C (default: 3°C) (step: 1°C)

It is recommended to choose [C-04] bigger than the default value to have an optimal operation when choosing possibility 2. Depending on the used boiler, the boiler efficiency should be chosen as follows:

#	Code	Description
[A.6.A]	[7-05]	<ul style="list-style-type: none"> • 0: Very high • 1: High • 2: Medium • 3: Low • 4: Very low

INFORMATION

Electricity price can only be set when bivalent is ON ([A.2.2.6.1] or [C-02]). These values can only be set in menu structure [7.4.5.1], [7.4.5.2] and [7.4.5.3]. Do NOT use overview settings.

INFORMATION

Boiler efficiency [A.6.A] or [7-05] becomes visible when bivalent is ON ([A.2.2.6.1] or [C-02]).

CAUTION

Make sure to observe all rules mentioned in application guideline 5 when bivalent operation function is enabled.

Daikin shall NOT be held liable for any damage resulting from failure to observe this rule.

INFORMATION

- The combination of setting [4-03]=0/2 with bivalent operation at low outdoor temperature can result in domestic hot water shortage.
- The bivalent operation function has no impact on the domestic water heating mode. The domestic hot water is still and only heated by the indoor unit.
- The permission signal for the auxiliary boiler is located on the EGRP1HB (digital I/O PCB). When it is activated, the contact X1, X2 is closed and open when it is deactivated. See illustration below for the schematic location of this contact.

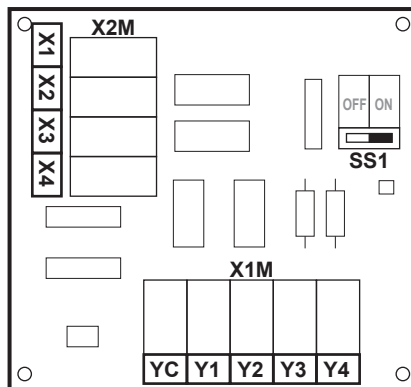

Bottom plate heater

Applies only to installation with an outdoor unit ERHQ and the option bottom plate heater kit is installed.

- [F-02] Bottom plate heater ON temperature: defines the outdoor temperature below which the bottom plate heater will be activated by indoor unit in order to prevent ice build-up in the bottom plate of the outdoor unit at lower outdoor temperatures.
- [F-03] Bottom plate heater hysteresis: defines the temperature difference between bottom plate heater ON temperature and the bottom plate heater OFF temperature.

Bottom plate heater

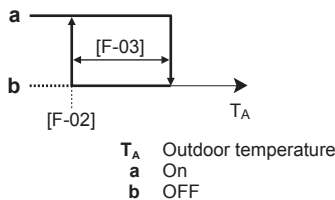

CAUTION

The bottom plate heater is controlled via EGRP1HB.

#	Code	Description
N/A	[F-02]	Bottom plate heater ON temperature: 3°C~10°C (default: 3°C)
N/A	[F-03]	Hysteresis: 2°C~5°C (default: 5°C)

INFORMATION

Dependent from setting [F-04] contact Y2 located on digital I/O PCB (EGRP1HB) controls the option bottom plate heater. See illustration below for the schematic location of this contact. For complete upwiring, see "14.6 Wiring diagram" on page 92.

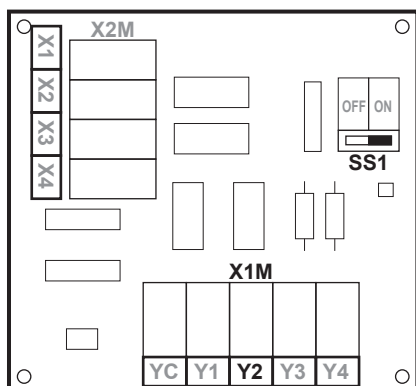

8.3.4 System settings

Priorities

For systems with separate domestic hot water tank (only for EHBH/X)

#	Code	Description
N/A	[5-02]	Space heating priority. Defines whether domestic hot water is made by booster heater only when outdoor temperature is below space heating priority temperature. It is recommended to enable this function to shorten tank heating operation time and guaranteed domestic hot water comfort. <ul style="list-style-type: none"> 0: disabled 1: enabled [5-01] Equilibrium temperature and [5-03] Space heating priority temperature are related to backup heater. So, you must set [5-03] equal or a few degrees higher than [5-01].
N/A	[5-03]	Space heating priority temperature. Defines the outdoor temperature which below the domestic hot water will be heated by booster heater only. Range: -15°C~35°C (default: 0°C).
N/A	[5-04]	Set point correction for domestic hot water temperature: set point correction for the desired domestic hot water temperature, to be applied at low outdoor temperature when space heating priority is enabled. The corrected (higher) set point will make sure that the total heat capacity of the water in the tank remains approximately unchanged, by compensating for the colder bottom water layer of the tank (because the heat exchanger coil is not operational) with a warmer top layer. Range: 0°C~20°C (default: 10°C).
N/A	[C-00]	If a solar kit is installed, what has priority to heat up the tank? <ul style="list-style-type: none"> 0: Solar kit 1: Heat pump

#	Code	Description
N/A	[C-01]	If there is a simultaneous demand for space heating/cooling and domestic hot water heating (by heat pump), which operation mode has priority? <ul style="list-style-type: none"> 0: The operation mode with the highest request has priority. 1: Always space heating/cooling has priority.

For systems with an integrated domestic hot water tank (only for EHVH/X)

#	Code	Description
N/A	[5-02]	Space heating priority. Defines whether backup heater will assist the heat pump during domestic hot water operation. Consequence: Shorter tank heating operation time and shorter interruption of the space heating cycle. This setting MUST always be 1. [5-01] Equilibrium temperature and [5-03] Space heating priority temperature are related to backup heater. So, you must set [5-03] equal or a few degrees higher than [5-01]. If the backup heater operation is limited ([4-00]=0) and the outdoor temperature is lower than setting [5-03], the domestic hot water will not be heated with the backup heater.
N/A	[5-03]	Space heating priority temperature. Defines the outdoor temperature which below the backup heater will assist during domestic hot water heating.
N/A	[C-00]	If a solar kit is installed, what has priority to heat up the tank? <ul style="list-style-type: none"> 0: Solar kit 1: Heat pump
N/A	[C-01]	If there is a simultaneous demand for space heating/cooling and domestic hot water heating (by heat pump), which operation mode has priority? <ul style="list-style-type: none"> 0: The operation mode with the highest request has priority. 1: Always space heating/cooling has priority.

Auto-restart

When power returns after a power supply failure, the auto restart function reapplies the remote controller settings at the time of the power failure. Therefore, it is recommended to always enable the function.

If the preferential kWh rate power supply is of the type that power supply is interrupted, always enable the auto restart function. Continuous indoor unit control can be guaranteed independent of the preferential kWh rate power supply status, by connecting the indoor unit to a normal kWh rate power supply.

8 Configuration

#	Code	Description
[A.6.1]	[3-00]	Is the auto restart function of the unit allowed? <ul style="list-style-type: none"> 0: No 1 (default): Yes

Preferential kWh rate power supply

#	Code	Description
[A.2.1.6]	[D-01]	Connection to a preferential kWh rate power supply: <ul style="list-style-type: none"> 0 (default): The outdoor unit is connected to a normal power supply. 1: The outdoor unit is connected to a preferential kWh rate power supply. When the preferential kWh rate signal is sent by the electricity company, the contact will open and the unit will go in forced off mode. When the signal is released again, the voltage-free contact will close and the unit will restart operation. Therefore, always enable the auto restart function. 2: The outdoor unit is connected to a preferential kWh rate power supply. When the preferential kWh rate signal is sent by the electricity company, the contact will close and the unit will go in forced off mode. When the signal is released again, the voltage-free contact will open and the unit will restart operation. Therefore, always enable the auto restart function.
[A.6.2.1]	[D-00]	Which heaters are allowed to operate during preferential kWh rate power supply? <ul style="list-style-type: none"> 0 (default): None 1: Booster heater only 2: Backup heater only 3: All heaters <p>See table below.</p> <p>Settings 1, 2 and 3 are only meaningful if the preferential kWh rate power supply is of type 1 or indoor unit is connected to a normal kWh rate power supply (via 30-31 X2M) and the backup heater and booster heater are NOT connected to the preferential kWh rate power supply.</p>

Only for EHBH/X + EKHW:

[D-00]	Booster heater	Backup heater	Compressor
0 (default)	Forced OFF	Forced OFF	Forced OFF
1	Permitted	Permitted	
2	Forced OFF		
3	Permitted		

Only for EHVH/X: Do NOT use 1 or 3.

[D-00]	Backup heater	Compressor
0 (default)	Forced OFF	Forced OFF
2	Allowed	

Power saving function



INFORMATION

Only applicable for ERLQ004~008CAV3.

Defines whether the outdoor unit power supply can be interrupted (internally by indoor unit control) during stand-still conditions (no space heating/cooling nor domestic hot water demand). The final decision to allow power interruption of the outdoor unit during standstill depends on the ambient temperature, compressor conditions and minimum internal timers.

To enable the power saving function setting, [E-08] needs to be enabled on the user interface in combination with the removal of the power saving connector at the outdoor unit.



NOTICE

The power saving connector at the outdoor unit shall only be removed when the main power supply to the application is switched OFF.

In case of ERLQ004~008CAV3

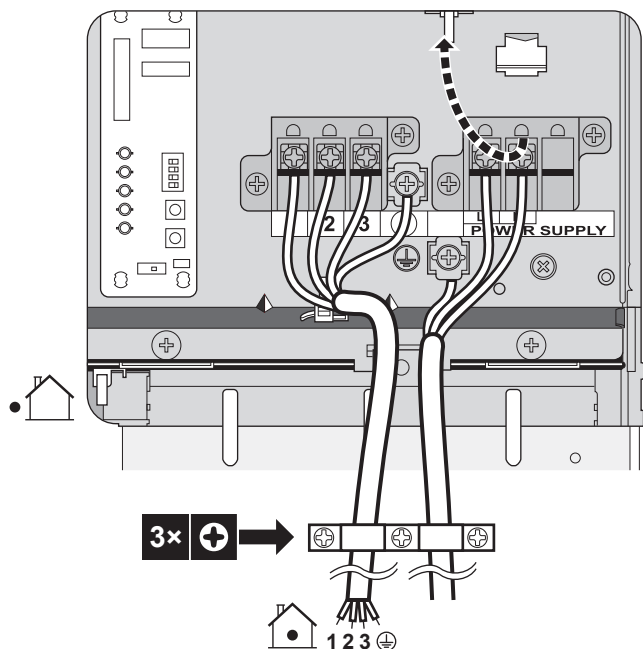

#	Code	Description
N/A	[E-08]	Power saving function for outdoor unit: <ul style="list-style-type: none"> 0: Disabled 1 (default): Enabled

In case of ERHQ011~016BAV3, ERHQ011~016BAW1, ERLQ011~016CAV3, and ERLQ011~016CAW1

Do NOT change the default setting.

#	Code	Description
N/A	[E-08]	Power saving function for outdoor unit: <ul style="list-style-type: none"> 0 (default): Disabled 1: Enabled

Power consumption control

Only applicable for EHBH/X04+08 + EHVH/X04+08. See "5 Application guidelines" on page 11 for detailed information about this functionality.

Pwr consumpt. control

#	Code	Description
[A.6.3.1]	[4-08]	Mode: <ul style="list-style-type: none"> 0 (No limitation)(default): Disabled. 1 (Continuous): Enabled: You can set one power limitation value (in A or kW) to which the system power consumption will be limited for all the time. 2 (Digital inputs): Enabled: You can set up to four different power limitation values (in A or kW) to which the system power consumption will be limited when the corresponding digital input asks.
[A.6.3.2]	[4-09]	Type: <ul style="list-style-type: none"> 0 (Current): The limitation values are set in A. 1 (Power)(default): The limitation values are set in kW.
[A.6.3.3]	[5-05]	Value: Only applicable in case of full time power limitation mode. 0 A~50 A, step: 1 A (default: 50 A)
[A.6.3.4]	[5-09]	Value: Only applicable in case of full time power limitation mode. 0 kW~20 kW, step: 0.5 kW (default: 20 kW)
Amp. limits for DI: Only applicable in case of power limitation mode based on digital inputs and based on current values.		
[A.6.3.5.1]	[5-05]	Limit DI1 0 A~50 A, step: 1 A (default: 50 A)
[A.6.3.5.2]	[5-06]	Limit DI2 0 A~50 A, step: 1 A (default: 50 A)
[A.6.3.5.3]	[5-07]	Limit DI3 0 A~50 A, step: 1 A (default: 50 A)
[A.6.3.5.4]	[5-08]	Limit DI4 0 A~50 A, step: 1 A (default: 50 A)
kW limits for DI: Only applicable in case of power limitation mode based on digital inputs and based on power values.		
[A.6.3.6.1]	[5-09]	Limit DI1 0 kW~20 kW, step: 0.5 kW (default: 20 kW)
[A.6.3.6.2]	[5-0A]	Limit DI2 0 kW~20 kW, step: 0.5 kW (default: 20 kW)
[A.6.3.6.3]	[5-0B]	Limit DI3 0 kW~20 kW, step: 0.5 kW (default: 20 kW)
[A.6.3.6.4]	[5-0C]	Limit DI4 0 kW~20 kW, step: 0.5 kW (default: 20 kW)
Priority: Only applicable in case of an optional EKHV.		

#	Code	Description
[A.6.3.7]	[4-01]	Power consumption control DISABLED [4-08]=0 <ul style="list-style-type: none"> 0 (None)(default): Backup heater and booster heater can operate simultaneously. 1 (BSH): The booster heater is prioritized. 2 (BUH): The backup heater is prioritized. Power consumption control ENABLED [4-08]=1 or 2 <ul style="list-style-type: none"> 0 (None)(default): Depending on the power limitation level, the booster heater will be limited first, before the backup heater is limited. 1 (BSH): Depending on the power limitation level, the backup heater will be limited first, before the booster heater is limited. 2 (BUH): Depending on the power limitation level, the booster heater will be limited first, before the backup heater is limited.

Note: In case of power consumption control is DISABLED (for all models) the setting [4-01] defines whether backup heater and booster heater can operate simultaneously, or if the booster heater/backup heater has priority over the backup heater/booster heater.

In case of power consumption control is ENABLED (only for EHBH/X04+08 and EHVH/X04+08), the setting [4-01] defines the priority of the electrical heaters depending on applicable limitation.

#	Code	Description
[A.6.3.7]	[4-01]	<ul style="list-style-type: none"> 0 (None)(default): No heater is prioritized. If the power consumption control is enabled, the booster heater will be limited first. 1 (BSH): The booster heater is prioritized. If the power consumption control is enabled, the backup heater (step 1 and/or step 2) will be limited first, before the booster heater is limited. 2 (BUH): The backup heater is prioritized. If the power consumption control is enabled, the booster heater will be limited first, before the backup heater is limited.

Average timer

The average timer corrects the influence of ambient temperature variations. The weather-dependent set point calculation is done on the average outdoor temperature.

The outdoor temperature is averaged over the selected time period.

#	Code	Description
[A.6.4]	[1-0A]	Outdoor average timer: <ul style="list-style-type: none"> 0: No averaging (default) 1: 12 hours 2: 24 hours 3: 48 hours 4: 72 hours

8 Configuration



INFORMATION

If the power saving function is activated (see [E-08]), the average outdoor temperature calculation is only possible in case the external outdoor temperature sensor is used. See "5.7 Setting up an external temperature sensor" on page 22.

Offset temperature external outdoor ambient sensor

Only applicable in case of an external outdoor ambient sensor is installed and configured.

You can calibrate the external outdoor ambient temperature sensor. It is possible to give an offset to the thermistor value. The setting can be used to compensate for situations where the external outdoor ambient sensor cannot be installed on the ideal installation location (see installation).

#	Code	Description
[A.6.5]	[2-0B]	-5°C~5°C, step: 0.5°C (default: 0°C)

Forced defrost

You can manually start a defrost operation.

The decision to execute the manual defrost operation is made by the outdoor unit and depends on ambient and heat exchanger conditions. When the outdoor unit accepted the forced defrost operation, will be displayed on the user interface. If is NOT displayed within 6 minutes after forced defrost operation was enabled, the outdoor unit ignored the forced defrost request.

#	Code	Description
[A.6.6]	N/A	Do you want to start a defrost operation?

Pump operation

When the pump operation function is disabled the pump will stop if the outdoor temperature is higher than the value set by [4-02] or if the outdoor temperature drops below the value set by [F-01]. When the pump operation is enabled, the pump operation is possible at all outdoor temperatures.

#	Code	Description
N/A	[F-00]	Pump operation: <ul style="list-style-type: none"> ▪ 0: Disabled if outdoor temperature is higher than [4-02] or lower than [F-01] depending on heating/cooling operation mode. ▪ 1: Possible at all outdoor temperatures.

Pump operation during flow abnormality [F-09] defines whether the pump stops at flow abnormality or allow to continue operation when flow abnormality occurs. This functionality is only valid in specific conditions where it is preferable to keep the pump active when $T_a < 4^\circ\text{C}$ (pump will be activated for 10 minutes and deactivated after 10 minutes). Daikin shall NOT be held liable for any damage resulting this functionality.

#	Code	Description
N/A	[F-09]	Pump continue operation when flow abnormality: <ul style="list-style-type: none"> ▪ 0: Pump will be deactivated. ▪ 1: Pump will be activated when $T_a < 4^\circ\text{C}$ (10 minutes ON – 10 minutes OFF)

Pump speed limitation

Pump speed limitation [9-0D] defines the maximum pump speed. In normal conditions, the default setting should NOT be modified. The pump speed limitation will be overruled when the flow rate is in the range of the minimum flow (error 7H).

#	Code	Description
N/A	[9-0D]	Pump speed limitation <ul style="list-style-type: none"> ▪ 0: No limitation. ▪ 1~4: General limitation. There is limitation in all conditions. The required delta T control and comfort are NOT guaranteed. ▪ 5~8 (default: 6): Limitation when no actuators. When there is no heating/cooling output, the pump speed limitation is applicable. When there is heating/cooling output, the pump speed is only determined by delta T in relation to the required capacity. With this limitation range, delta T is possible and the comfort is guaranteed.

8.4 Menu structure: Overview user settings

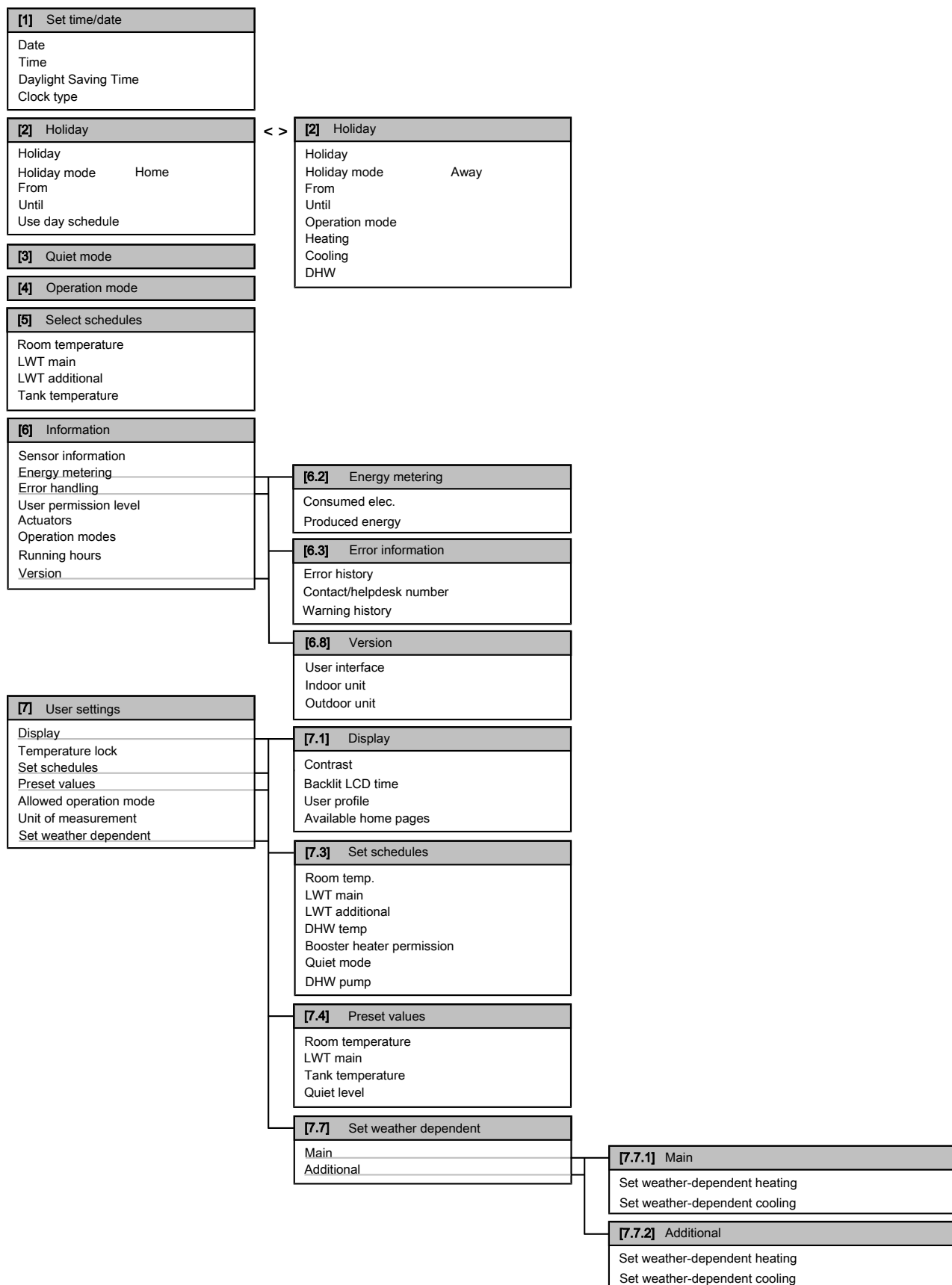

8 Configuration



INFORMATION

Depending on the selected installer settings, settings will be visible/invisible.

8.5 Menu structure: Overview installer settings

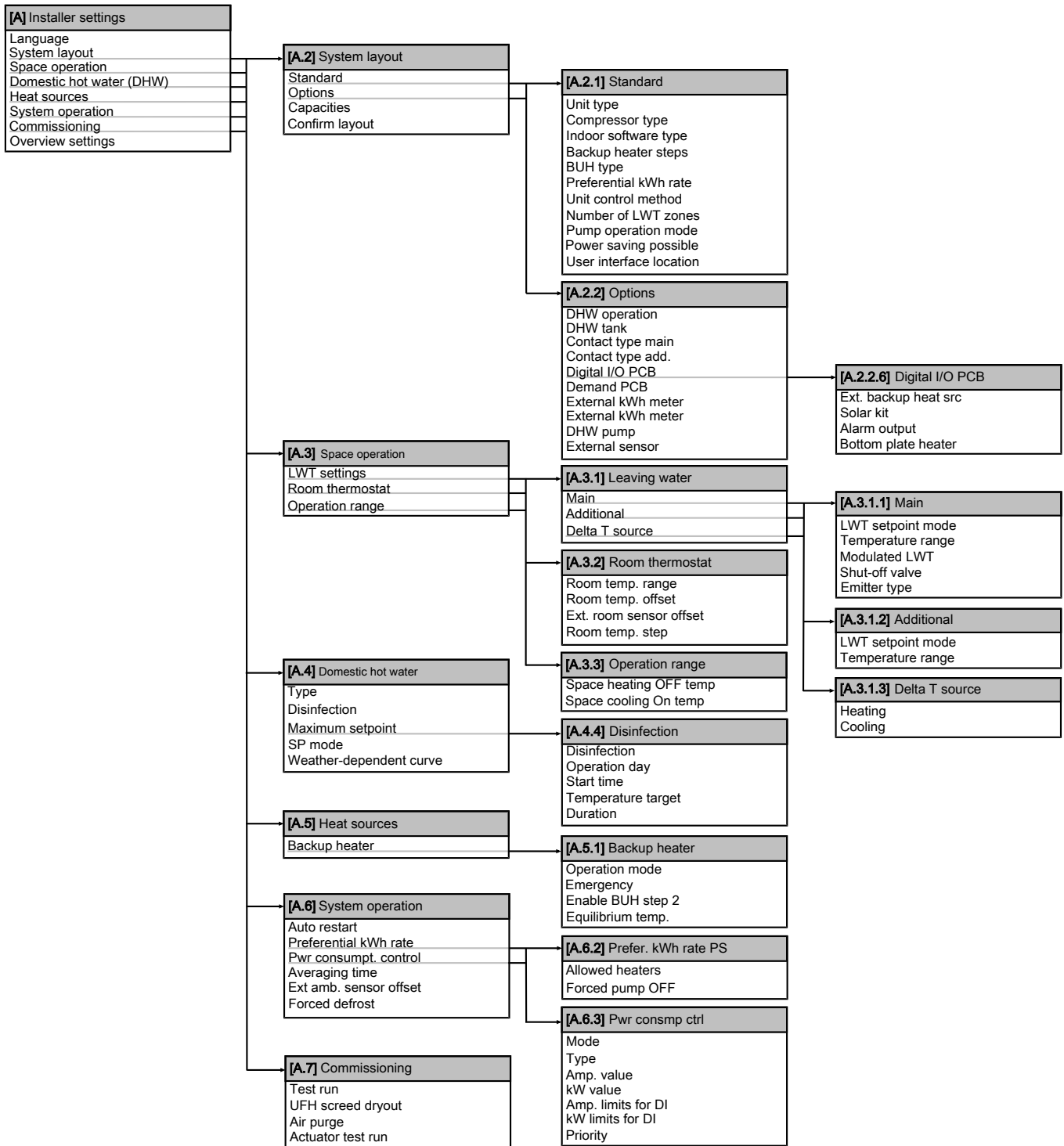

INFORMATION

Depending on the selected installer settings, settings will be visible/invisible.

9 Commissioning

9.1 Overview: Commissioning

This chapter describes what you have to do and know to commission the system after it is configured.

Typical workflow

Commissioning typically consists of the following stages:

- 1 Checking the "Checklist before commissioning".
- 2 Performing an air purge.
- 3 Performing a test run for the system.
- 4 If necessary, performing a test run for one or more actuators.
- 5 If necessary, performing an underfloor heating screed dryout.

9.2 Precautions when commissioning



INFORMATION

During the first running period of the unit, the required power may be higher than stated on the nameplate of the unit. This phenomenon is caused by the compressor, that needs a continuous run time of 50 hours before reaching smooth operation and stable power consumption.



NOTICE

Before starting up the system, the unit **MUST** be energised for at least 2 hours. The crankcase heater needs to heat up the compressor oil to avoid oil shortage and compressor breakdown during startup.



NOTICE

NEVER operate the unit without thermistors and/or pressure sensors/switches. Burning of the compressor might result.



NOTICE

Do **NOT** operate the unit until the refrigerant piping is complete (when operated this way, the compressor will break).

9.3 Checklist before commissioning

Do **NOT** operate the system before the following checks are OK:

<input type="checkbox"/>	You read the complete installation instructions, as described in the installer reference guide .
<input type="checkbox"/>	The indoor unit is properly mounted.
<input type="checkbox"/>	The outdoor unit is properly mounted.
<input type="checkbox"/>	The following field wiring has been carried out according to this document and the applicable legislation: <ul style="list-style-type: none"> ▪ Between the local supply panel and the outdoor unit ▪ Between indoor unit and outdoor unit ▪ Between the local supply panel and the indoor unit ▪ Between the indoor unit and the valves (if applicable) ▪ Between the indoor unit and the room thermostat (if applicable) ▪ Between the indoor unit and the domestic hot water tank (if applicable) ▪ Between the gas boiler and the local supply panel (only applicable in case of hybrid system)
<input type="checkbox"/>	The system is properly earthed and the earth terminals are tightened.

<input type="checkbox"/>	The fuses or locally installed protection devices are installed according to this document, and have not been bypassed.
<input type="checkbox"/>	The power supply voltage matches the voltage on the identification label of the unit.
<input type="checkbox"/>	There are NO loose connections or damaged electrical components in the switch box.
<input type="checkbox"/>	There are NO damaged components or squeezed pipes on the inside of the indoor and outdoor units.
<input type="checkbox"/>	Depending on the backup heater type, backup heater circuit breaker F1B on the switch box is turned ON.
<input type="checkbox"/>	Only for tanks with built-in booster heater: The booster heater circuit breaker F2B on the switch box is turned ON.
<input type="checkbox"/>	There are NO refrigerant leaks .
<input type="checkbox"/>	The refrigerant pipes (gas and liquid) are thermally insulated.
<input type="checkbox"/>	The correct pipe size is installed and the pipes are properly insulated.
<input type="checkbox"/>	There is NO water leak inside the indoor unit.
<input type="checkbox"/>	The shut-off valves are properly installed and fully open.
<input type="checkbox"/>	The stop valves (gas and liquid) on the outdoor unit are fully open.
<input type="checkbox"/>	The air purge valve is open (at least 2 turns).
<input type="checkbox"/>	The pressure relief valve purges water when opened.
<input type="checkbox"/>	The minimum water volume is guaranteed in all conditions. See "To check the water volume" in "6.4 Preparing water piping" on page 25 .

9.4 Checklist during commissioning

<input type="checkbox"/>	The minimum flow rate during backup heater/defrost operation is guaranteed in all conditions. See "To check the water volume and flow rate" in "6.4 Preparing water piping" on page 25 .
<input type="checkbox"/>	To perform an air purge .
<input type="checkbox"/>	To perform a test run .
<input type="checkbox"/>	To perform an actuator test run .
<input type="checkbox"/>	Underfloor screed dryout function The underfloor screed dryout function is started (if necessary).

9.4.1 To check the minimum flow rate

- 1 Confirm according to the hydraulic configuration which space heating loops can be closed due to mechanical, electronic, or other valves.
- 2 Close all space heating loops that can be closed (see previous step).
- 3 Start the pump test run operation (see ["9.4.4 To perform an actuator test run" on page 75](#)).
- 4 Go to [6.1.8]: > Information > Sensor information > Flow rate to check the flow rate. During pump test run operation, the unit can operate below this minimum required flow rate that is needed during defrost/backup heater operation.

9 Commissioning

Bypass valve foreseen?	
Yes	No
Modify the bypass valve setting to reach the minimum required flow rate + 2 l/min	In case the actual flow rate is below the minimum flow rate (required during defrost/backup heater operation), modifications at hydraulic configuration are required. Increase the space heating loops that can NOT be closed or install a pressure controlled bypass valve.

9.4.2 Air purge function

When commissioning and installing the unit, it is very important to remove all air in the water circuit. When the air purge function is running, the pump operates without actual operation of the unit and the removal of air in the water circuit will start.

NOTICE

Before starting the air purge, open the safety valve and check if the circuit is sufficiently filled with water. Only if water escapes the valve after opening it, you can start the air purge procedure.

There are 2 modes for purging air:

- Manually: the unit will operate with a fixed pump speed and in a fixed or custom position of the 3-way valve. The custom position of the 3-way valve is a helpful feature to remove all air from the water circuit in the space heating or the domestic hot water heating mode. The operation speed of the pump (slow or quick) can also be set.
- Automatic: the unit automatically changes the pump speed and the position of the 3-way valve between the space heating or the domestic hot water heating mode.

Typical workflow

Purging the air from the system should consist of:

- Performing a manual air purge
- Performing an automatic air purge

INFORMATION



Start by performing a manual air purge. When almost all the air is removed, perform an automatic air purge. If necessary, repeat performing the automatic air purge until you are sure that all air is removed from the system. During air purge function, pump speed limitation [9-0D] is NOT applicable.

Make sure the user interface shows the home screens and that the space heating and domestic hot water demands are turned off.

The air purge function automatically stops after 30 minutes.

To perform a manual air purge

Prerequisite: Make sure the user interface shows the home screens and that the space heating and domestic hot water demands are turned off.

- Set the user permission level to Installer. See ["To set the user permission level to Installer" on page 47](#).
- Set the air purge mode: go to [A.7.3.1]  > Installer settings > Commissioning > Air purge > Type.
- Select Manual and press **OK**.
- Go to [A.7.3.4]  > Installer settings > Commissioning > Air purge > Start air purge and press **OK** to start the air purge function.

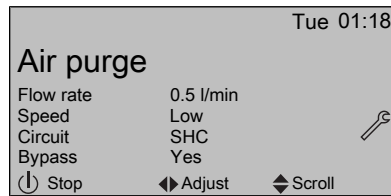

Result: The manual air purge starts and the following screen appears.



- Use the **◀** and **▶** buttons to scroll to Speed.
- Use the **▲** and **▼** buttons to set the desired pump speed.
Result: Low
Result: High
- If applicable, set the desired position of the 3-way valve. Use the **◀** and **▶** buttons to scroll to Circuit.
- Use the **▲** and **▼** buttons to set the desired position of the 3-way valve.
Result: SHC
Result: Tank

To perform an automatic air purge

Prerequisite: Make sure the user interface shows the home screens and that the space heating and domestic hot water demands are turned off.

- Set the user permission level to Installer. See ["To set the user permission level to Installer" on page 47](#).
- Set the air purge mode: go to [A.7.3.1]  > Installer settings > Commissioning > Air purge > Type.
- Select Automatic and press **OK**.
- Go to [A.7.3.4]  > Installer settings > Commissioning > Air purge > Start air purge and press **OK** to start the air purge function.

Result: Air purging will start and the following screen will be shown.

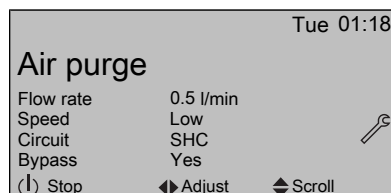

To interrupt air purge

- Press **⏻** and press **OK** to confirm the interruption of the air purge function.

9.4.3 To perform a test run

Prerequisite: Make sure the user interface shows the home screens and that the space heating and domestic hot water demands are turned off.

- Set the user permission level to Installer. See ["To set the user permission level to Installer" on page 47](#).
- Go to [A.7.1]:  > Installer settings > Commissioning > Test run.
- Select a test and press **OK**. **Example:** Heating.
- Select OK and press **OK**.

Result: The test run starts. It stops automatically when done (±30 min). To stop it manually, press **⏻**, select OK and press **OK**.

i INFORMATION

If 2 user interfaces are present, you can start a test run from both user interfaces.

- The user interface used to start the test run displays a status screen.
- The other user interface displays a "busy" screen. You cannot use the user interface as long as the "busy" screen is shown.

If the installation of the unit has been done correctly, the unit will start up during test operation in the selected operation mode. During the test mode, the correct operation of the unit can be checked by monitoring leaving water temperature (heating/cooling mode) and tank temperature (domestic hot water mode).

To monitor the temperature, go to [A.6] and select the information you want to check.

9.4.4 To perform an actuator test run

Purpose of the actuator test run is to confirm the operation of the different actuators (e.g., when you select pump operation, a test run of the pump will start).

Prerequisite: Make sure the user interface shows the home screens and that the space heating and domestic hot water demands are turned off.

- 1 Set the user permission level to Installer. See ["To set the user permission level to Installer" on page 47](#).
- 2 Make sure the room temperature control, the leaving water temperature control and the domestic hot water control are turned OFF via the user interface.
- 3 Go to [A.7.4]:  > Installer settings > Commissioning > Actuator test run.
- 4 Select an actuator and press **OK**. **Example:** Pump.
- 5 Select OK and press **OK**.

Result: The actuator test run starts. It automatically stops when finished. To stop it manually, press , select OK and press **OK**.

Possible actuator test runs

- Booster heater test
- Backup heater (step 1) test
- Backup heater (step 2) test
- Pump test

i INFORMATION

Make sure that all air is purged before executing the test run. Also avoid disturbances in the water circuit during the test run.

- Solar pump test
- 2-way valve test
- 3-way valve test
- Bottom plate heater test
- Bivalent signal test
- Alarm output test
- Cooling/heating signal test
- Quick heat-up test
- Circulation pump test

9.4.5 Underfloor heating screed dryout

This function is used for drying out the screed of an underfloor heating system very slowly during the construction of a house. It allows the installer to program and execute this program.

Make sure the user interface shows the home screens and that the space heating and domestic hot water demands are turned off.

This function can be executed without finishing the outdoor installation. In this case, the backup heater will perform the screed dryout and supply the leaving water without heat pump operation.

When no outdoor unit is installed yet, then connect the main power supply cable to the indoor unit via X2M/30 and X2M/31. See ["7.9.7 To connect the main power supply" on page 42](#).

i INFORMATION

- If Emergency is set to Manual ([A.5.1.2]=0), and the unit is triggered to start emergency operation, the user interface will ask confirmation before starting. The underfloor heating screed dryout function is active even if the user does NOT confirm emergency operation.
- During underfloor heating screed dryout, pump speed limitation [9-0D] is NOT applicable.

! NOTICE

The installer is responsible for:

- contacting the screed manufacturer for the initial heating instructions to avoid cracking the screed,
- programming the underfloor heating screed dryout schedule according to the above instruction of the screed manufacturer,
- checking the proper functioning of the setup on a regular basis,
- selecting the correct program complying with the type of the used screed of the floor.

! NOTICE

Room frost protection is default disabled ([2-06]=0). Do NOT enable this function until the underfloor screed dryout function is completed successfully. Ignoring this notice can result in cracking of the screed.

The installer can program up to 20 steps. For each step he needs to enter:

- 1 the duration in hours, up to 72 hours,
- 2 the desired leaving water temperature.

Example:

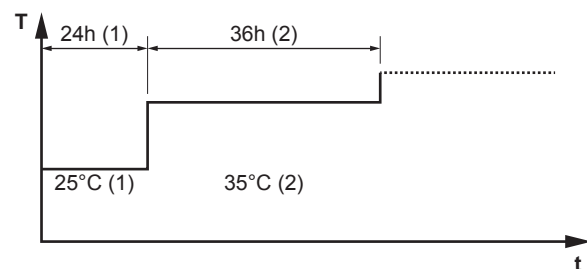

- T Desired leaving water temperature (15~55°C)
- t Duration (1~72 h)
- (1) Action step 1
- (2) Action step 2

10 Hand-over to the user

To program an underfloor heating screed dryout schedule

- 1 Set the user permission level to Installer. See "To set the user permission level to Installer" on page 47.
- 2 Go to [A.7.2]: > Installer settings > Commissioning > UFH screed dryout > Set dryout schedule.
- 3 Use the , , , and to program the schedule.
 - Use and to scroll through the schedule.
 - Use and to adjust the selection.If a time is selected, you can set the duration between 1 and 72 hours.
If a temperature is selected, you can set the desired leaving water temperature between 15°C and 55°C.
- 4 To add a new step, select "-h" or "-" on an empty line and press .
- 5 To delete a step, set the duration to "-" by pressing .
- 6 Press to save the schedule.

It is important that there is no empty step in the program. The schedule will stop when a blank step is programmed OR when 20 consecutive steps have been executed.

To perform an underfloor heating screed dryout

INFORMATION
Preferential kWh rate power supply cannot be used in combination with underfloor heating screed dryout.

Prerequisite: Make sure there is ONLY 1 user interface connected to your system to perform an underfloor heating screed dryout.

Prerequisite: Make sure the user interface shows the home screens and that the space heating and domestic hot water demands are turned off.

- 1 Go to [A.7.2]: > Installer settings > Commissioning > UFH screed dryout.
- 2 Set a dryout program.
- 3 Select Start dryout and press .
- 4 Select OK and press .

Result: The underfloor heating screed dryout starts and following screen will be shown. It stops automatically when done. To stop it manually, press , select OK and press .



To readout the status of an underfloor heating screed dryout

- 1 Press .
- 2 The current step of the program, the total remaining time, and the current desired leaving water temperature will be displayed.

INFORMATION
There is limited access to the menu structure. Only the following menus can be accessed:

- Information.
- Installer settings > Commissioning > UFH screed dryout.

To interrupt an underfloor heating screed dryout

When the program is stopped by an error, an operation switch off, or a power failure, the U3 error will be displayed on the user interface. To resolve the error codes, see "12.4 Solving problems based on error codes" on page 80. To reset the U3 error, your User permission level needs to be Installer.

- 1 Go to the underfloor heating screed dryout screen.
- 2 Press .
- 3 Press to interrupt the program.
- 4 Select OK and press .

Result: The underfloor heating screed dryout program is stopped.

When the program is stopped due to an error, an operation switch-off, or a power failure, you can read out the underfloor heating screed dryout status.

- 5 Go to [A.7.2]: > Installer settings > Commissioning > UFH screed dryout > Dryout status > Stopped at and followed by the last executed step.
- 6 Modify and restart the execution of the program.

10 Hand-over to the user

Once the test run is finished and the unit operates properly, please make sure the following is clear for the user:

- Fill in the installer setting table (in the operation manual) with the actual settings.
- Make sure that the user has the printed documentation and ask him/her to keep it for future reference. Inform the user that he can find the complete documentation on the url as earlier described in this manual.
- Explain the user how to properly operate the system and what to do in case of problems.
- Show the user what to do in relation to maintaining the unit.
- Explain the user about energy saving tips as described in the operation manual.

11 Maintenance and service

NOTICE
Maintenance should preferably be carried out yearly by an installer or service agent.

11.1 Overview: Maintenance and service

This chapter contains information about:

- The yearly maintenance of the outdoor unit
- The yearly maintenance of the indoor unit

11.2 Maintenance safety precautions



DANGER: RISK OF ELECTROCUTION



DANGER: RISK OF BURNING



NOTICE: Risk of electrostatic discharge

Before performing any maintenance or service work, touch a metal part of the unit in order to eliminate static electricity and to protect the PCB.

11.2.1 Opening the indoor unit

See "7.2.4 To open the switch box cover of the indoor unit" on page 30.

11.3 Checklist for yearly maintenance of the outdoor unit

Check the following at least once a year:

- Outdoor unit heat exchanger.

The heat exchanger of the outdoor unit can get blocked up due to dust, dirt, leaves, etc. It is recommended to clean the heat exchanger yearly. A blocked heat exchanger can lead to too low pressure or too high pressure leading to worse performance.

11.4 Checklist for yearly maintenance of the indoor unit

Check the following at least once a year:

- Water pressure
- Water filter
- Water pressure relief valve
- Pressure relief valve of the domestic hot water tank
- Switch box
- Booster heater of the domestic hot water tank

Water pressure

Check whether the water pressure is above 1 bar. If it is lower, add water.

Water filter

Clean the water filter.



NOTICE

Handle the water filter with care. Do NOT use excessive force when you reinsert the water filter so as NOT to damage the water filter mesh.

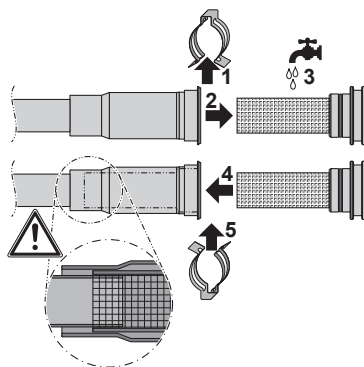

Water pressure relief valve

Open the valve and check if it operates correctly. **The water may be very hot!**

Checkpoints are:

- The water flow coming from the relief valve is high enough, no blockage of the valve or in between piping is suspected.
- Dirty water coming out of the relief valve:
 - open the valve until the discharged water does NOT contain dirt anymore
 - flush the system and install an additional water filter (a magnetic cyclone filter is preferable).

To make sure this water originates from the tank, check after a tank heat up cycle.

It is recommended to do this maintenance more frequently.

Relief valve of the domestic hot water tank (field supply)

Open the valve and check the correct operation. **Water may be very hot!**

Checkpoints are:

- The water flow coming from the relief valve is high enough, no blockage of the valve or in between piping is suspected.
- Dirty water coming out of the relief valve:
 - open the valve until the discharged water does not contain dirt anymore
 - flush and clean the complete tank, including the piping between the relief valve and cold water inlet.

To make sure this water originates from the tank, check after a tank heat up cycle.

It is recommended to do this maintenance more frequently.

Switch box

- Carry out a thorough visual inspection of the switch box and look for obvious defects such as loose connections or defective wiring.
- Using an ohmmeter, check if contactors K1M, K2M, K3M and K5M (depending on your installation) operate correctly. All contacts of these contactors must be in open position when the power is turned OFF.



WARNING

If the internal wiring is damaged, it has to be replaced by the manufacturer, its service agent or similarly qualified persons.

Booster heater of the domestic hot water tank



INFORMATION

Only for wall-mounted units equipped with a domestic hot water tank with a built-in electrical booster heater (EKHW).

It is recommended to remove lime buildup on the booster heater to extend its life span, especially in regions with hard water. To do so, drain the domestic hot water tank, remove the booster heater from the domestic hot water tank and immerse in a bucket (or similar) with lime-removing product for 24 hours.

12 Troubleshooting

12 Troubleshooting

12.1 Overview: Troubleshooting

This chapter describes what you have to do in case of problems.

It contains information about:

- Solving problems based on symptoms
- Solving problems based on error codes

Before troubleshooting

Carry out a thorough visual inspection of the unit and look for obvious defects such as loose connections or defective wiring.

12.2 Precautions when troubleshooting



WARNING

- When carrying out an inspection on the switch box of the unit, always make sure that the unit is disconnected from the mains. Turn off the respective circuit breaker.
- When a safety device was activated, stop the unit and find out why the safety device was activated before resetting it. NEVER bridge safety devices or change their values to a value other than the factory default setting. If you are unable to find the cause of the problem, call your dealer.



DANGER: RISK OF ELECTROCUTION



WARNING

Prevent hazard due to the inadvertent resetting of the thermal cut-out: this appliance must NOT be supplied through an external switching device, such as a timer, or connected to a circuit that is regularly turned ON and OFF by the utility.



DANGER: RISK OF BURNING

12.3 Solving problems based on symptoms

12.3.1 Symptom: The unit is NOT heating or cooling as expected

Possible causes	Corrective action
The temperature setting is NOT correct	Check the temperature setting on the remote controller. Refer to the operation manual.

Possible causes	Corrective action
The water flow is too low	<p>Check and make sure that:</p> <ul style="list-style-type: none"> • All shut-off valves of the water circuit are completely open. • The water filter is clean. Clean if necessary. • There is no air in the system. Purge air if necessary. You can purge air manually (see "To perform a manual air purge" on page 74) or use the automatic air purge function (see "To perform an automatic air purge" on page 74). • The water pressure is >1 bar. • The expansion vessel is NOT broken. • The resistance in the water circuit is NOT too high for the pump (see "14.9 ESP curve" on page 110). <p>If the problem persists after you have conducted all of the above checks, contact your dealer. In some cases, it is normal that the unit decides to use a low water flow.</p>
The water volume in the installation is too low	<p>Make sure that the water volume in the installation is above the minimum required value (see "6.4.3 To check the water volume and flow rate" on page 26).</p>

12.3.2 Symptom: The compressor does NOT start (space heating or domestic water heating)

Possible causes	Corrective action
The unit must start up out of its operation range (the water temperature is too low)	<p>If the water temperature is too low, the unit uses the backup heater to reach the minimum water temperature first (15°C).</p> <p>Check and make sure that:</p> <ul style="list-style-type: none"> • The power supply to the backup heater is correctly wired. • The backup heater thermal protector is NOT activated. • The backup heater contactors are NOT broken. <p>If the problem persists after you have conducted all of the above checks, contact your dealer.</p>
The preferential kWh rate power supply settings and electrical connections do NOT match	<p>This should match with the connections as explained in "6.5 Preparing electrical wiring" on page 27 and "7.9.7 To connect the main power supply" on page 42.</p>
The preferential kWh rate signal was sent by the electricity company	<p>Wait for the power to return (2 hours max.).</p>

12.3.3 Symptom: The pump is making noise (cavitation)

Possible causes	Corrective action
There is air in the system	Purge air manually (see "To perform a manual air purge" on page 74) or use the automatic air purge function (see "To perform an automatic air purge" on page 74).
The water pressure at the pump inlet is too low	Check and make sure that: <ul style="list-style-type: none"> ▪ The water pressure is >1 bar. ▪ The manometer is not broken. ▪ The expansion vessel is NOT broken. ▪ The pre-pressure setting of the expansion vessel is correct (see "6.4.4 Changing the pre-pressure of the expansion vessel" on page 27).

12.3.4 Symptom: The pressure relief valve opens

Possible causes	Corrective action
The expansion vessel is broken	Replace the expansion vessel.
The water volume in the installation is too high	Make sure that the water volume in the installation is below the maximum allowed value (see "6.4.3 To check the water volume and flow rate" on page 26 and "6.4.4 Changing the pre-pressure of the expansion vessel" on page 27).
The water circuit head is too high	The water circuit head is the difference in height between the indoor unit and the highest point of the water circuit. If the indoor unit is located at the highest point of the installation, the installation height is considered 0 m. The maximum water circuit head is 10 m. Check the installation requirements.

12.3.5 Symptom: The water pressure relief valve leaks

Possible causes	Corrective action
Dirt is blocking the water pressure relief valve outlet	Check whether the pressure relief valve works correctly by turning the red knob on the valve counterclockwise: <ul style="list-style-type: none"> ▪ If you do NOT hear a clacking sound, contact your dealer. ▪ If the water keeps running out of the unit, close both the water inlet and outlet shut-off valves first and then contact your dealer.

12.3.6 Symptom: The space is NOT sufficiently heated at low outdoor temperatures

Possible causes	Corrective action
The backup heater operation is not activated	Check and make sure that: <ul style="list-style-type: none"> ▪ The backup heater operation mode is enabled. Go to: <ul style="list-style-type: none"> ▪ [A.5.1.1] > Installer settings > Heat sources > Backup heater > Operation mode [4-00] ▪ The thermal protector of the backup heater has not been activated. If it has, check: <ul style="list-style-type: none"> ▪ The water pressure ▪ Whether there is air in the system ▪ The air purge operation Press the reset button in the switch box. See "14.4 Components" on page 88 for the location of the reset button.
The backup heater equilibrium temperature has not been configured correctly	Increase the "equilibrium temperature" to activate the backup heater operation at a higher outdoor temperature. Go to: <ul style="list-style-type: none"> ▪ [A.5.1.4] > Installer settings > Heat sources > Backup heater > Equilibrium temp. OR ▪ [A.8] > Installer settings > Overview settings [5-01]
Too much heat pump capacity is used for heating domestic hot water (applies only to installations with a domestic hot water tank)	Check and make sure that the "space heating priority" settings have been configured appropriately: <ul style="list-style-type: none"> ▪ Make sure that the "space heating priority status" has been enabled. Go to [A.8] > Installer settings > Overview settings [5-02] ▪ Increase the "space heating priority temperature" to activate backup heater operation at a higher outdoor temperature. Go to [A.8] > Installer settings > Overview settings [5-03]

12.3.7 Symptom: The pressure at the tapping point is temporarily unusual high



Possible causes	Corrective action
Failing or blocked pressure relief valve.	<ul style="list-style-type: none"> ▪ Flush and clean the complete tank including the piping between pressure relief valve and the cold water inlet. ▪ Replace the pressure relief valve.

12 Troubleshooting

12.3.8 Symptom: Decoration panels are pushed away due to a swollen tank

Possible causes	Corrective action
Failing or blocked pressure relief valve.	Contact your local dealer.

12.3.9 Symptom: Tank disinfection function is NOT completed correctly (AH-error)

Possible causes	Corrective action
The disinfection function was interrupted by domestic hot water tapping	Program the start-up of the disinfection function when the coming 4 hours NO domestic hot water tapping is expected.
Large domestic hot water tapping happened recently before the programmed start-up of the disinfection function	When the Domestic hot water > Type > Reheat or Reheat + sched. is selected, it is recommended to program the start-up the disinfection function at least 4 hours later than the last expected large hot water tapping. This start-up can be set by installer settings (disinfection function). When the Domestic hot water > Type > Scheduled only is selected, it is recommended to program a Storage eco 3 hours before the scheduled start-up of the disinfection function to preheat the tank.
The disinfection operation was stopped manually: with the user interface displaying the DHW home page and its user permission level set to Installer, the  button was pressed during disinfection operation.	Do NOT press the  button while the disinfection function is active.

12.4 Solving problems based on error codes

When a problem happens, an error code appears on the user interface. It is important to understand the problem and to take countermeasure before resetting the error code. This should be done by a licensed installer or by your local dealer.

This chapter gives you an overview of all error codes and the content of the error code as it appears on the user interface.

For a more detailed troubleshooting guideline for each error, please see the service manual.

12.4.1 Error codes: Overview

Error codes of the outdoor unit

Error code	Detailed error code	Description
A5	00	OU: High pressure cooling/Peak cut/ freeze protection problem. Please contact your dealer.
E1	00	OU: PCB defect. Power reset required. Please contact your dealer.

Error code	Detailed error code	Description
E3	00	OU: Actuation of high pressure switch (HPS). Please contact your dealer.
E5	00	OU: Overheat of inverter compressor motor. Please contact your dealer.
E6	00	OU: Compressor startup defect. Please contact your dealer.
E7	00	OU: Malfunction of outdoor unit fan motor. Please contact your dealer.
E8	00	OU: Power input overvoltage. Please contact your dealer.
EA	00	OU: Cool/heat switchover problem. Please contact your dealer.
H0	00	OU: Voltage/current sensor problem. Please contact your dealer.
H3	00	OU: Malfunction of high pressure switch (HPS) Please contact your dealer.
H6	00	OU: Malfunction of position detection sensor. Please contact your dealer.
H8	00	OU: Malfunction of compressor input (CT) system. Please contact your dealer.
H9	00	OU: Malfunction of outdoor air thermistor. Please contact your dealer.
F3	00	OU: Malfunction of discharge pipe temperature. Please contact your dealer.
F6	00	OU: Abnormal high pressure in cooling. Please contact your dealer.
FA	00	OU: Abnormal high pressure, actuation of HPS. Please contact your dealer.
JA	00	OU: Malfunction of high pressure sensor. Please contact your dealer.
J3	00	OU: Malfunction of discharge pipe thermistor. Please contact your dealer.

Error code	Detailed error code	Description
J6	00	OU: Malfunction of heat exchanger thermistor. Please contact your dealer.
L3	00	OU: Electrical box temperature rise problem. Please contact your dealer.
L4	00	OU: Malfunction of inverter radiating fin temperature rise. Please contact your dealer.
L5	00	OU: Inverter instantaneous overcurrent (DC). Please contact your dealer.
P4	00	OU: Malfunction of radiating fin temperature sensor. Please contact your dealer.
U0	00	OU: Shortage of refrigerant. Please contact your dealer.
U2	00	OU: Defect of power supply voltage. Please contact your dealer.
U7	00	OU: Transmission malfunction between main CPU- INV CPU. Please contact your dealer.
UA	00	OU: Indoor/outdoor combination problem. Power reset required.

Error codes of the indoor unit

Error code	Detailed error code	Description
A1	00	Zero cross detection problem. Power reset required. Please contact your dealer.
AA	01	Backup heater overheated. Power reset required. Please contact your dealer.
UA	00	Indoor unit, outdoor unit matching problem. Power reset required.
7H	01	Water flow problem.
89	01	Heat exchanger frozen.
8H	00	Abnormal increase outlet water temperature.

Error code	Detailed error code	Description
8F	00	Abnormal increase outlet water temperature (DHW).
C0	00	Flow sensor/switch malfunction. Please contact your dealer.
U3	00	Under floor heating screed dryout function not completed correctly.
81	00	Leaving water temperature sensor problem. Please contact your dealer.
C4	00	Heat exchanger temperature sensor problem. Please contact your dealer.
80	00	Returning water temperature sensor problem. Please contact your dealer.
U5	00	User interface communication problem.
U4	00	Indoor/outdoor unit communication problem.
EC	00	Abnormal increase tank temperature.
HC	00	Tank temperature sensor problem. Please contact your dealer.
CJ	02	Room temperature sensor problem. Please contact your dealer.
H1	00	External temperature sensor problem. Please contact your dealer.
89	02	Heat exchanger frozen.
A1	00	EEPROM reading error.
AH	00	Tank disinfection function not completed correctly.
89	03	Heat exchanger frozen.

13 Disposal

Error code	Detailed error code	Description
AJ	03	Too long DHW heat-up time required.
UA	17	Tank type problem

INFORMATION

In case of error code AH and no interruption of the disinfection function occurred due to domestic hot water tapping, following actions are recommended:

- When the Domestic hot water > Type > Reheat or Reheat + sched. is selected, it is recommended to program the start-up of the disinfection function at least 4 hours later than the last expected large hot water tapping. This start-up can be set by installer settings (disinfection function).
- When the Domestic hot water > Type > Scheduled only is selected, it is recommended to program a Storage eco 3 hours before the scheduled start-up of the disinfection function to preheat the tank.

NOTICE

When the minimum water flow (in relation to the applicable operation mode) is lower than described in the table below, the unit will stop operation and the user interface will display error 7H.

Minimum required flow during heat pump operation		
04 models	Heating	6 l/min
	Cooling	6 l/min
08 models	Heating	6 l/min
	Cooling	10 l/min
11 models	Heating	10 l/min
	Cooling	15 l/min
16 models	Heating	10 l/min
	Cooling	15 l/min

Minimum required flow during defrost operation	
04+08 models	12 l/min
11+16 models	15 l/min

Minimum required flow during backup heater operation	
All models	12 l/min

INFORMATION

Error AJ-03 is reset automatically from the moment there is a normal tank heat-up.

13 Disposal

13.1 Overview: Disposal

Typical workflow

Disposing of the system typically consists of the following stages:

- Pumping down the system.
- Dismantling the system according to the applicable legislation.
- Treating the refrigerant, oil and other parts according to the applicable legislation.

INFORMATION

For more details, see the service manual.

13.2 To pump down

Example: To protect the environment, pump down when relocating the unit or when disposing of the unit.

NOTICE

During pump down operation, stop the compressor before removing the refrigerant piping. If the compressor is still running and the stop valve is open during pump down, air will be sucked into the system. Compressor breakage and other injury will be the result due to abnormal pressure in the refrigerant cycle.

Pump down operation will extract all refrigerant from the system into the outdoor unit.

- Remove the valve lid from liquid stop valve and gas stop valve.
- Carry out the forced cooling operation.
- After 5 to 10 minutes (after only 1 or 2 minutes in case of very low ambient temperatures (<-10°C)), close the liquid stop valve with a hexagonal wrench.
- Check with the manifold if the vacuum is reached.
- After 2-3 minutes, close the gas stop valve and stop forced cooling operation.

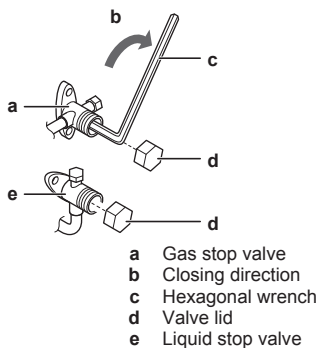

13.3 To start and stop forced cooling

Confirm that DIP switch SW2 is in COOL mode.

- 1 Press the forced cooling operation switch SW1 to begin forced cooling.
- 2 Press the forced cooling operation switch SW1 to stop forced cooling.

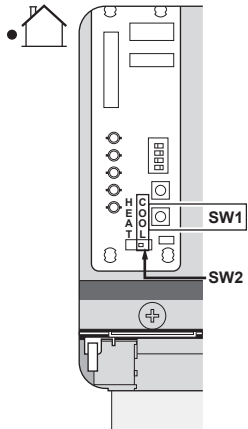

NOTICE

Take care that while running forced cooling operation, the water temperature remains higher than 5°C (see temperature read out of the indoor unit). You can achieve this, for example, by activating all fans of the fan coil units.

14 Technical data

14 Technical data

14.1 Overview: Technical data

This chapter contains information about:

- Dimensions and service space
- Centre of gravity
- Components
- Piping diagram
- Wiring diagram
- Technical specifications
- Operation range
- ESP curve

14.2 Dimensions and service space

14.2.1 Dimensions and service space: Outdoor unit

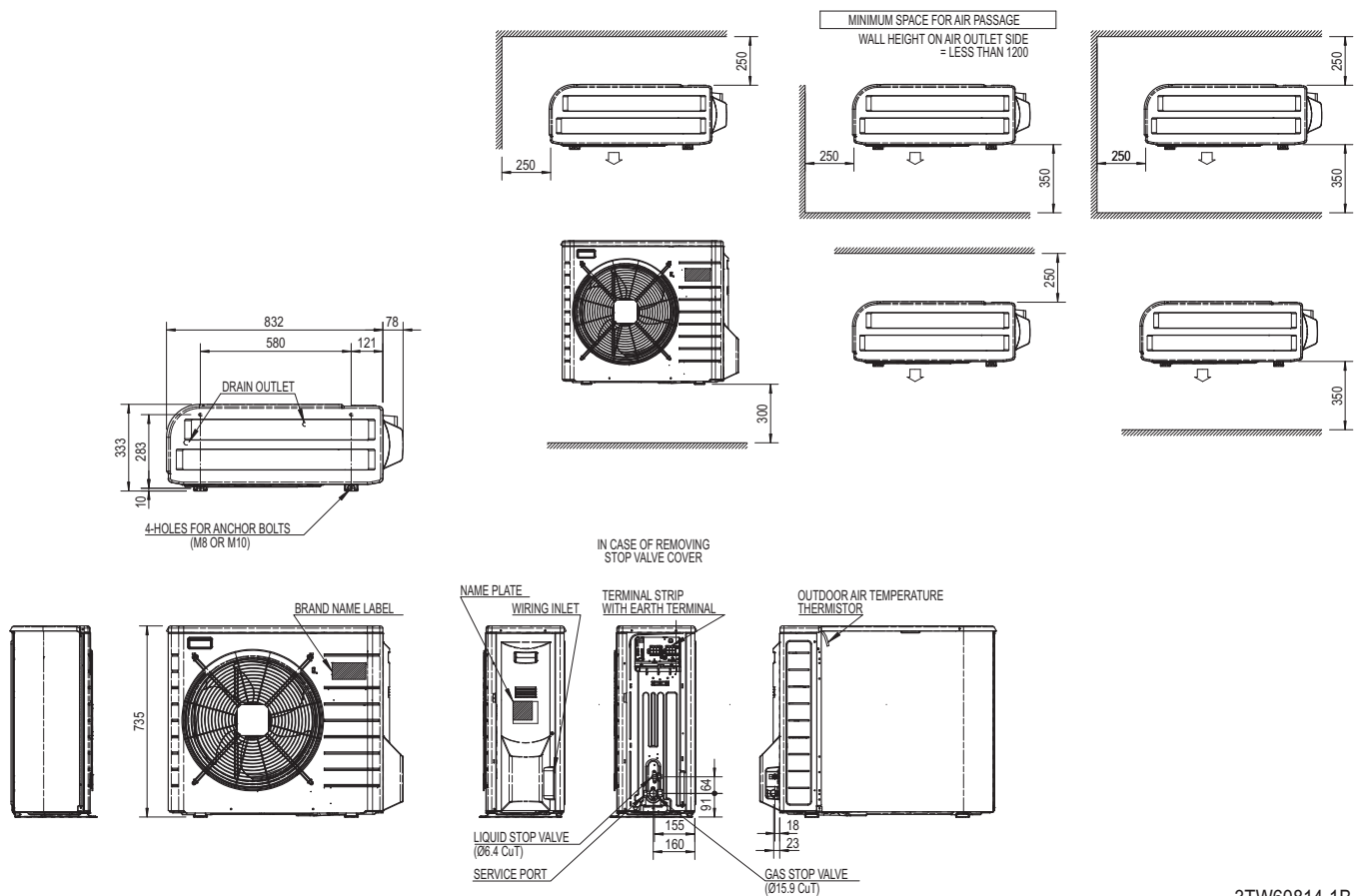

3TW60814-1B

14.2.2 Dimensions and service space: Indoor unit

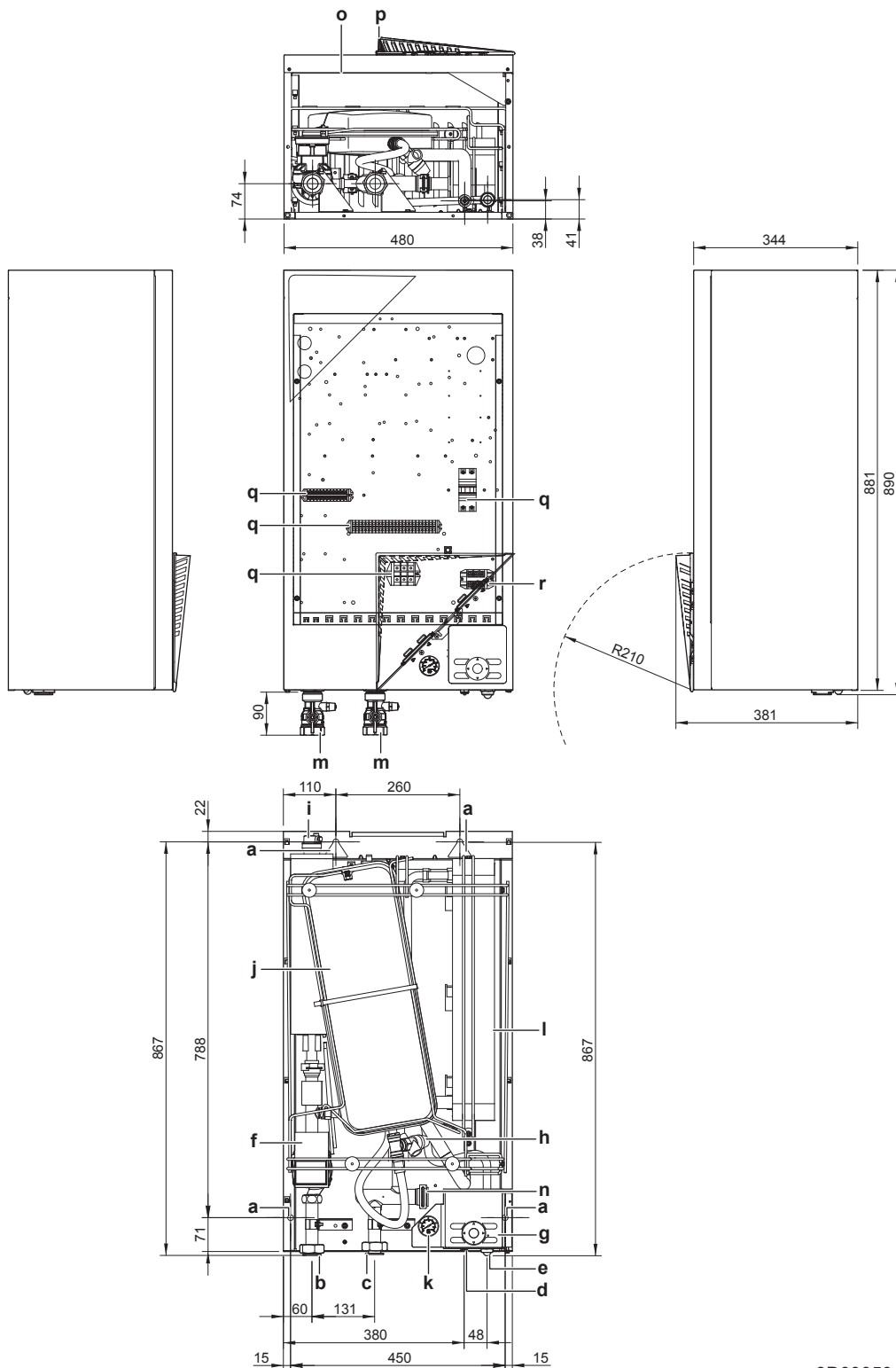

3D090501

- a Holes (Ø12 mm) for wall fixation
- b Water outlet connection (1-1/4" F BSP)
- c Water inlet connection (1-1/4" F BSP)
- d Refrigerant liquid connection Ø6.35 mm flare connection
- e Refrigerant suction connection Ø15.9 mm flare connection
- f Pump
- g User interface
- h Safety valve pressure
- i Air purge
- j Expansion vessel
- k Pressure gauge
- l Heat exchanger (refrigerant/water)
- m Stop valve with drain/fill valve (1-1/4" F BSP) (included accessory)
- n Water filter

14 Technical data

- o Wire entrance of the power supply/communication wire
- p Service door
- q Switch box terminals
- r Switch box terminals for the domestic hot water tank (option)

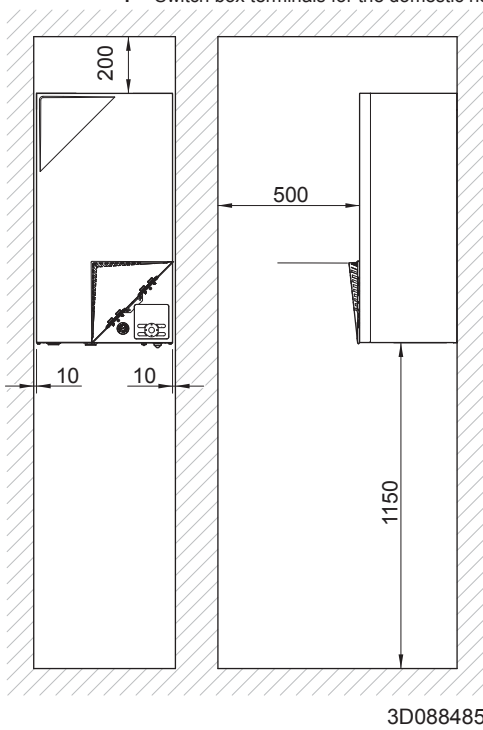

3D088485

14.3 Center of gravity

14.3.1 Center of gravity: Outdoor unit

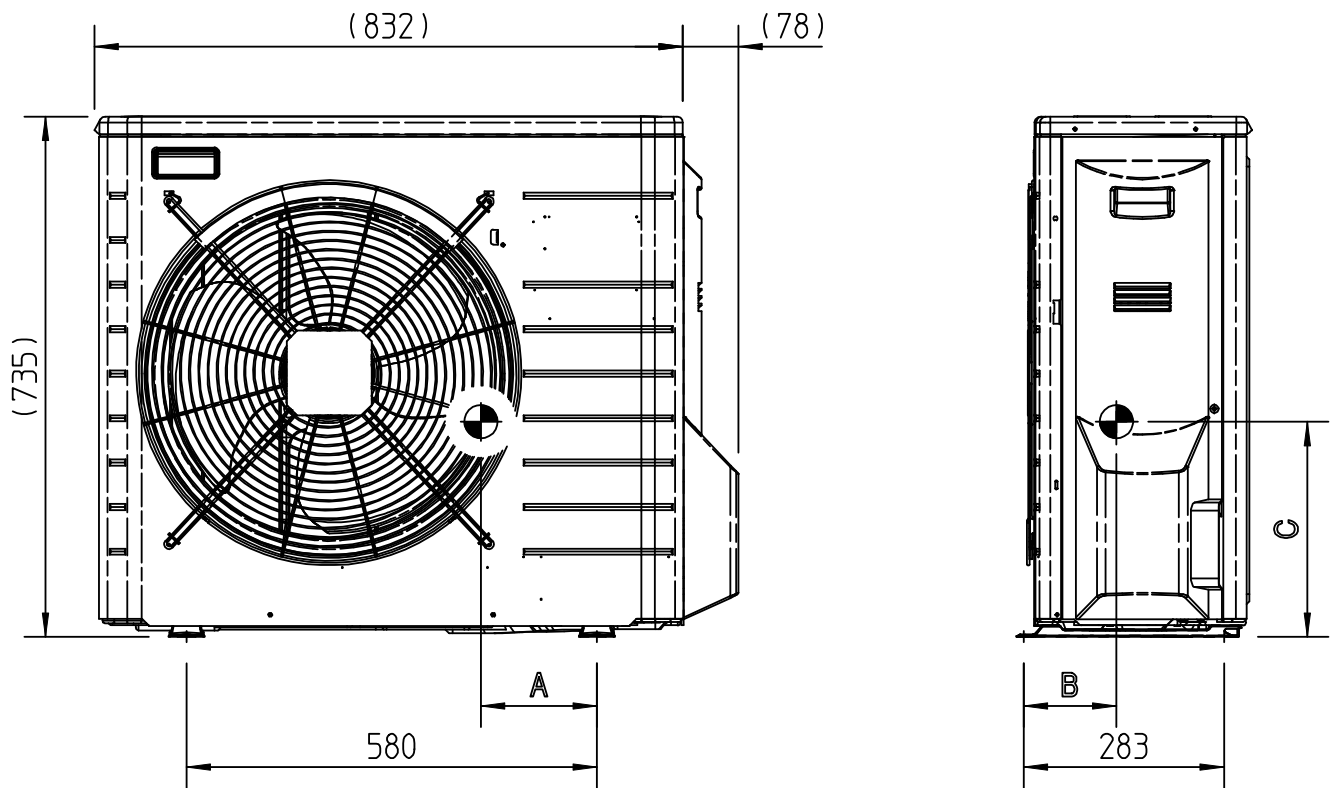

UNIT	A	B	C
ERLQ*004	169	130	306
ERLQ*006/8	164	131	306

4TW60819-1

14 Technical data

14.4 Components

14.4.1 Components: Outdoor unit

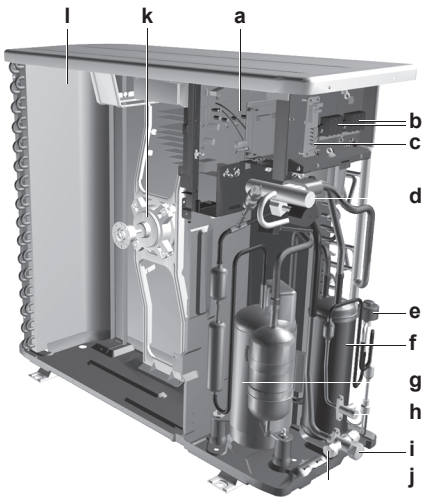

- a Switch box main PCB (inverter and control PCB)
- b Terminal communication and power supply
- c Service PCB
- d 4-way valve
- e Electronic expansion valve (main)
- f Accumulator
- g Compressor
- h Liquid stop valve
- i Gas stop valve
- j Service port
- k Fan motor
- l Heat exchanger

14.4.2 Components: Switch box (outdoor unit)

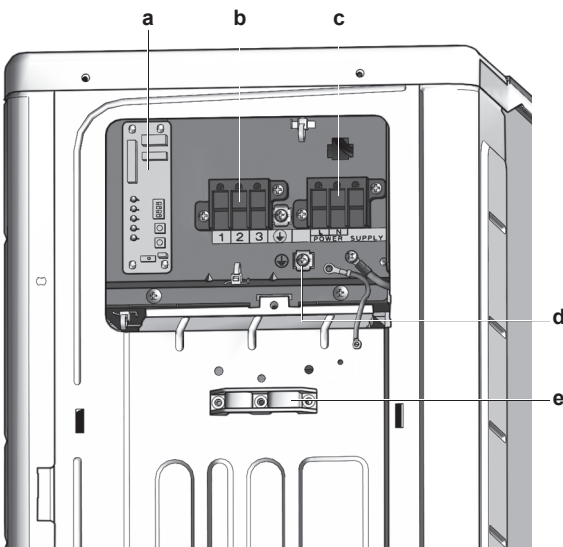

- a Service PCB
- b Terminal communication cable
- c Terminal power supply cable
- d Earth connection
- e Wire clamp

14.4.3 Components: Indoor unit

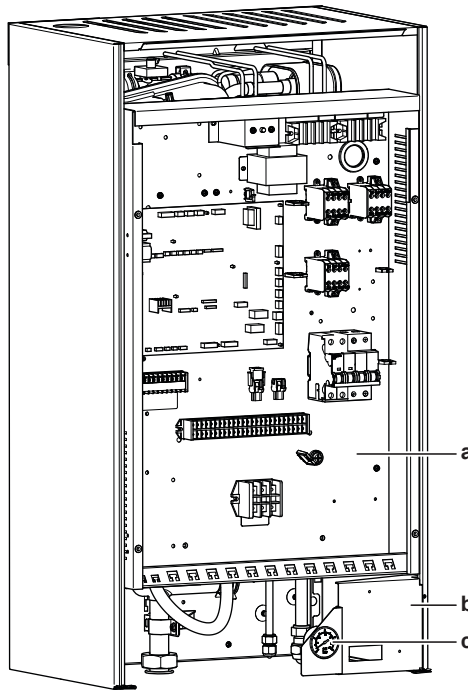

10+12 HP

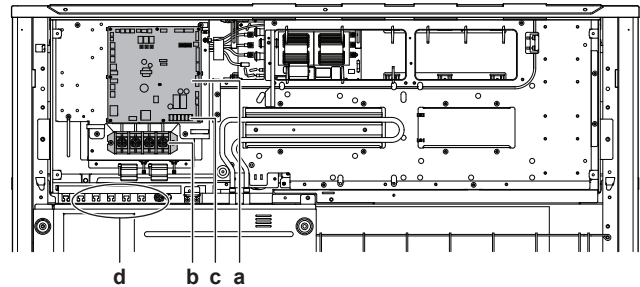

- a Switch box
Contains the main electronic and electrical parts of the indoor unit.
- b User interface (optional)
- c Manometer
Allows readout of the water pressure in the water circuit.
- d Air purge valve
Remaining air in the water circuit will be automatically removed via the air purge valve.
- e Expansion vessel (10 l)
- f Flow sensor
Gives feedback to the interface about the actual flow. Based on this information (and other), the interface adjusts the pump speed.
- g Heat exchanger
- h Water pump
Circulates the water in the water circuit.
- i Water filter
Removes dirt from the water to prevent damage to the pump or blockage of the heat exchanger.
- j Pressure relief valve
Prevents excessive water pressure in the water circuit by opening at 3 bar.
- k Refrigerant gas connection R410A
- l Refrigerant liquid connection R410A
- m Water inlet connection
- n Drain and fill valves
- o Shut-off valves (accessory)
Allows isolation of the indoor unit water circuit side from the residential water circuit side.
- p Water outlet connection

- q Thermistors
Determines the water and refrigerant temperature at various points in the circuit.
- r Backup heater thermal fuse
The fuse is blown when the temperature becomes higher than the backup heater thermal protector temperature.
- s Backup heater thermal protector
The protector activates when the temperature of the backup heater becomes too high.
- t Backup heater
Provides additional heating in case of cold outdoor temperatures. Also serves as backup in case of malfunctioning of the outdoor unit.
- u Air valve

14.4.4 Components: Switch box (indoor unit)

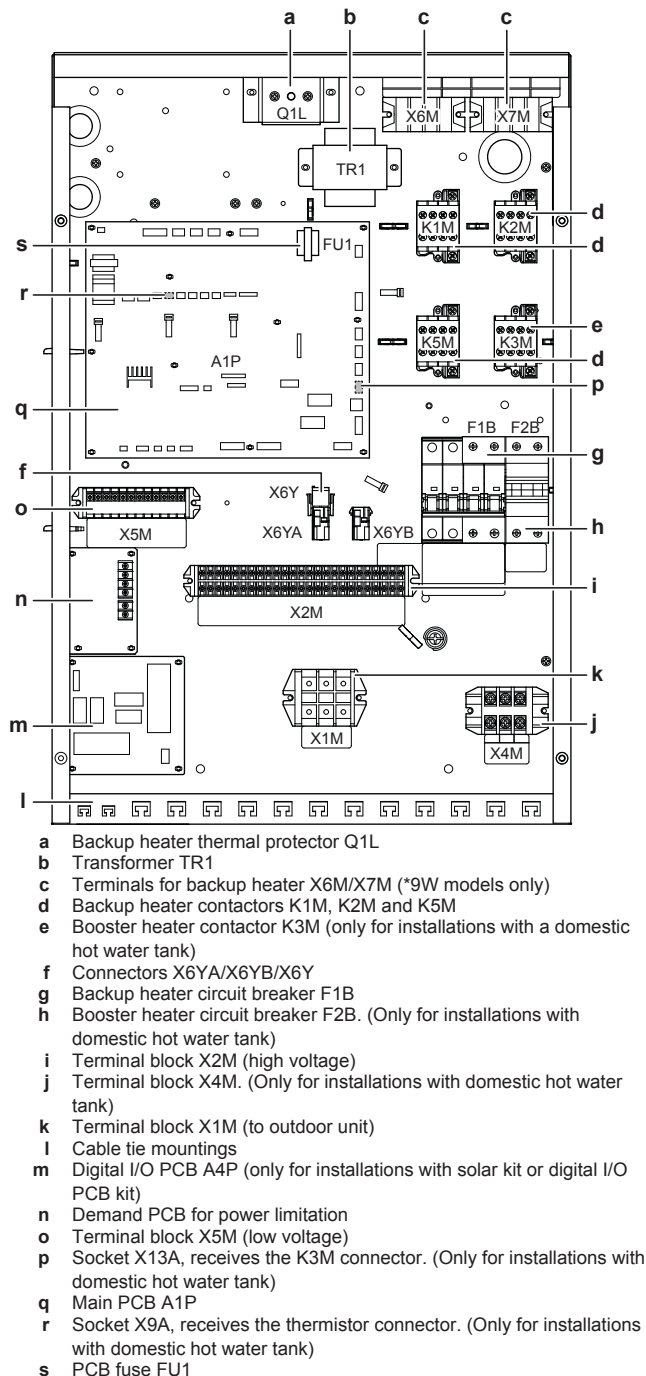

14 Technical data

14.5 Piping diagram

14.5.1 Piping diagram: Outdoor unit

OUTDOOR UNIT

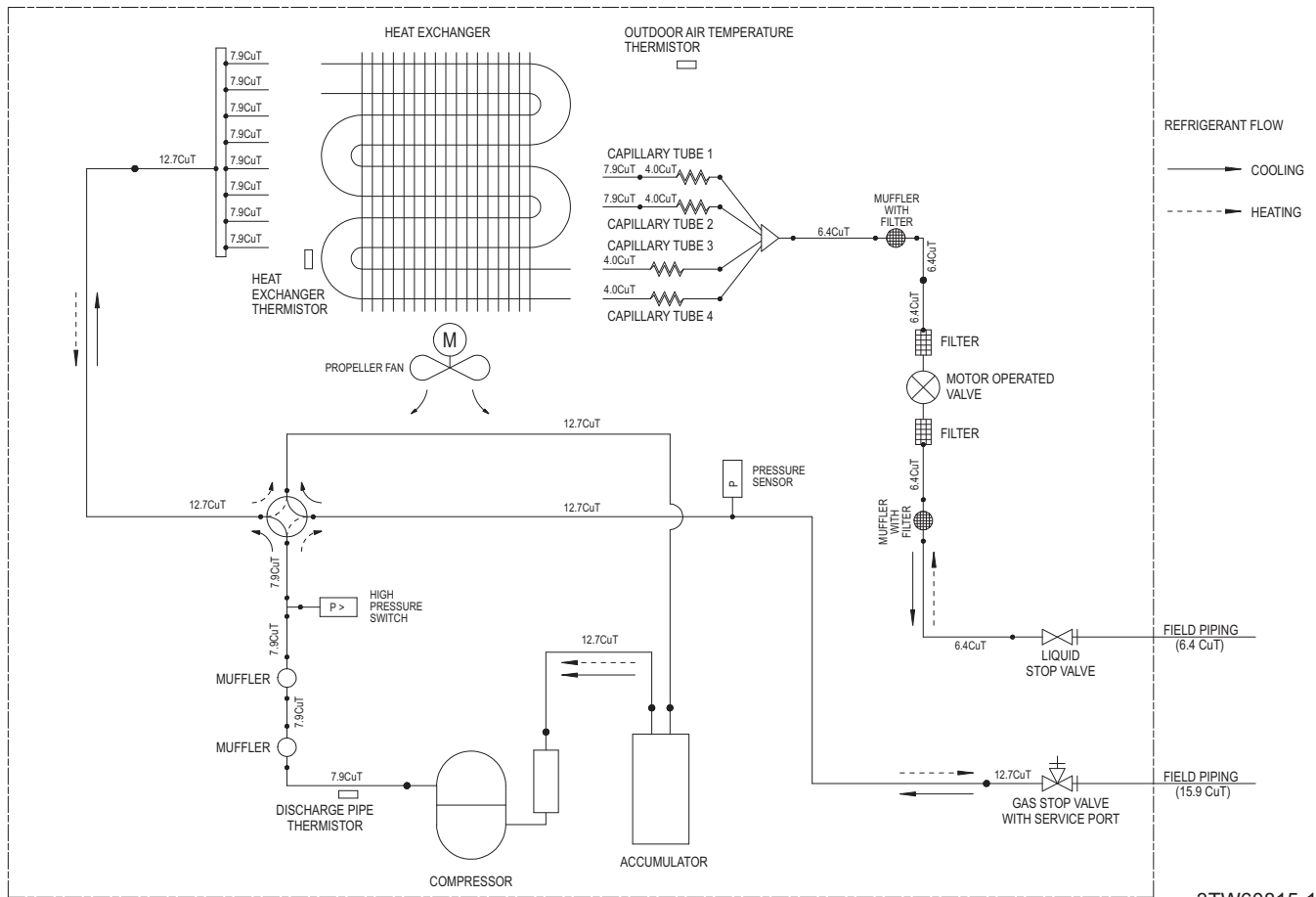

3TW60815-1

14.5.2 Piping diagram: Indoor unit

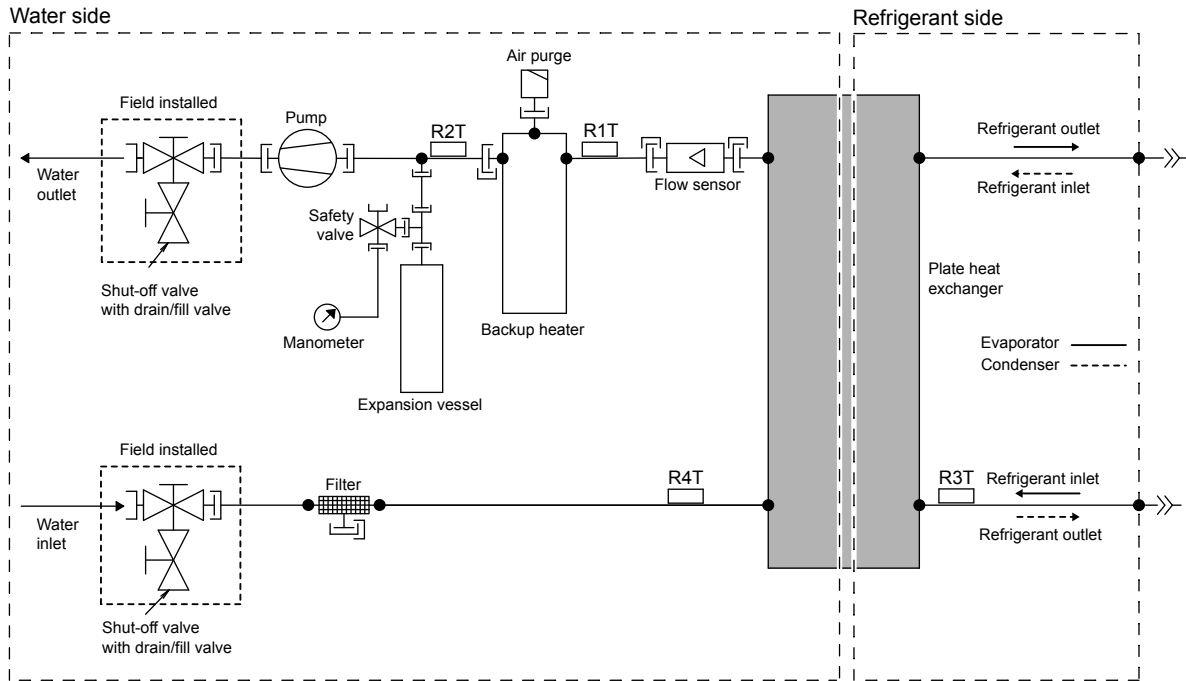

LEGEND	
	Check valve
	Flare connection
	Spinned pipe
	Pinched pipe
	Screw connection
	Quick coupling
	Flange connection
	Brazed connection

Thermistor	Description
R4T	Inlet water thermistor
R3T	Refrigerant liquid side thermistor
R2T	Outlet water backup heater thermistor
R1T	Outlet water heat exchanger thermistor

3D088485

14 Technical data

14.6 Wiring diagram

14.6.1 Wiring diagram: Outdoor unit

See the internal wiring diagram supplied with the unit (on the inside of the indoor unit switch box cover). The abbreviations used are listed below.

Only for ERLQ004CAV3

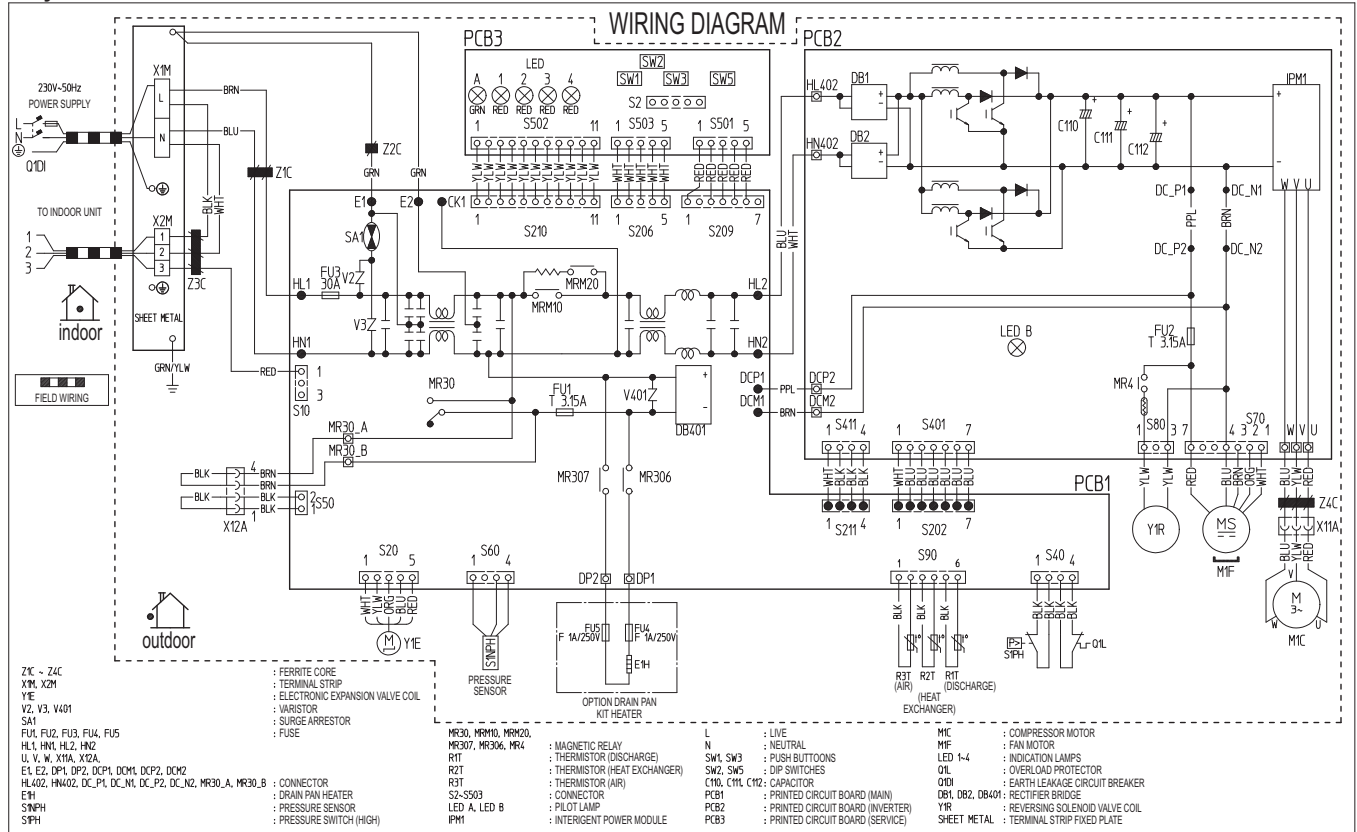

Only for ERLQ006CAV3+ERLQ008CAV3

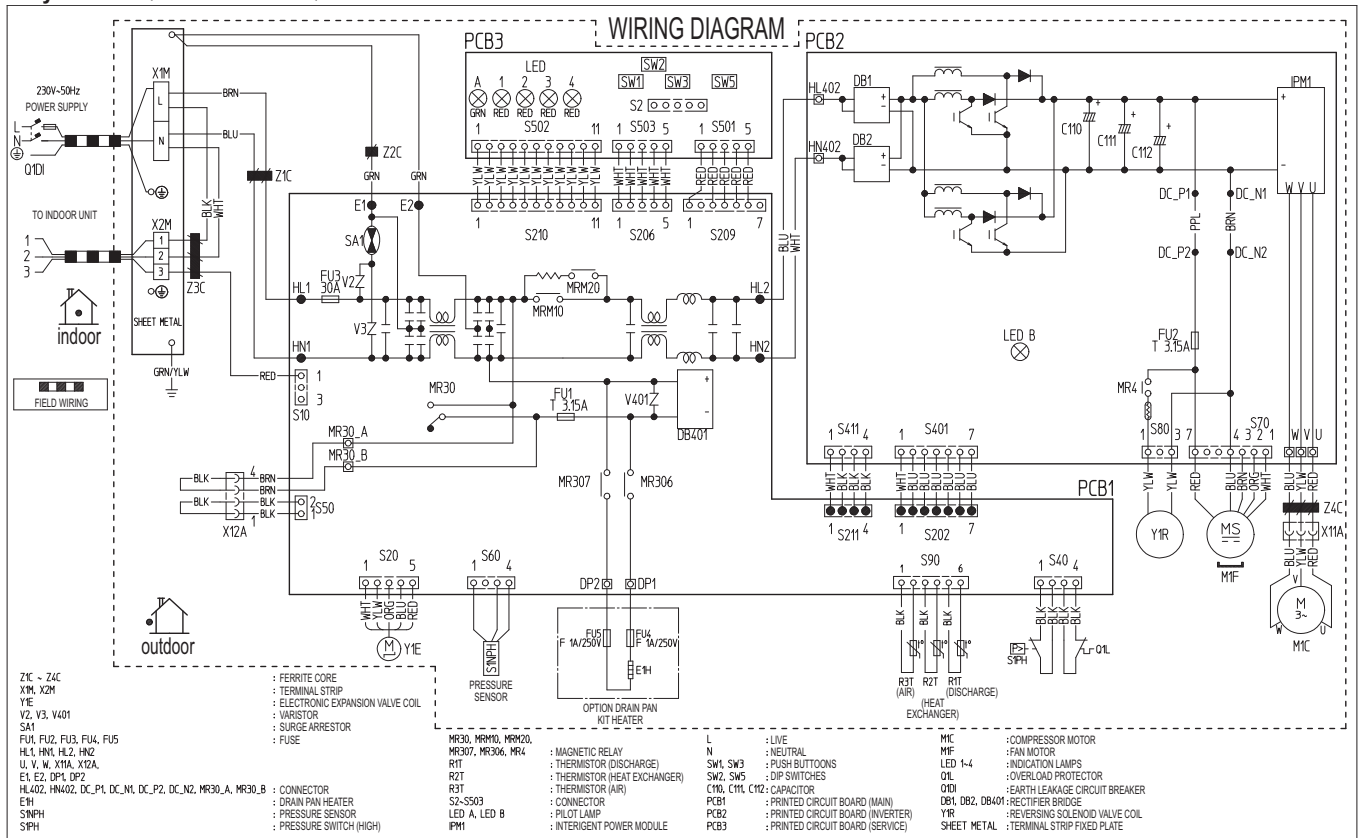

NOTES: REFER TO PURCHASING SPECIFICATION AS303002, UNLESS OTHERWISE SPECIFIED
THIS DRAWING WAS DRAWN ON CAD SYSTEM
SIZE: LENGTH 140 x WIDTH 230.

3TW60816-2

C110~C112	Capacitor	R1T	Thermistor (discharge)
DB1, DB2, DB401	Rectifier bridge	R2T	Thermistor (heat exchanger)
DC_N1, DC_N2	Connector	R3T	Thermistor (air)
DC_P1, DC_P2	Connector	S1NPH	Pressure sensor
DC_P1, DC_P2	Connector	S1PH	High pressure switch
DP1, DP2	Connector	S2~S503	Connector
E1, E2	Connector	SA1	Surge arrestor
E1H	Drain pan heater	SHEET METAL	Sheet metal
FU1~FU5	Fuse	SW1, SW3	Push buttons
HL1, HL2, HL402	Connector	SW2, SW5	DIP switch
HN1, HN2, HN402	Connector	U	Connector
IPM1	Interigent power module	V	Connector
L	Live	V2, V3, V401	Varistor
LED 1~LED 4	Indication lamps	W	Connector
LED A, LED B	Pilot lamp	X11A, X12A	Connector
M1C	Compressor motor	X1M, X2M	Terminal strip
M1F	Compressor fan	Y1E	Electronic expansion valve
MR30, MRM306, MRM307, MR4	Magnetic relay	Y1R	Reversing solenoid valve coil
MRM10, MRM20	Magnetic relay	Z1C~Z4C	Ferrite core
MR30_A~MR30_B	Connector	== ■■■ ==	Field wiring
N	Neutral	□□□□	Terminal strip
PCB1	Printed circuit board (main)	⊞	Connector
PCB2	Printed circuit board (inverter)	○	Terminal
PCB3	Printed circuit board (service)	⊞	Protective earth
Q1DI	Earth leakage circuit breaker	BLK	Black
Q1L	Overload protector	BLU	Blue

14 Technical data

BRN	Brown
GRN	Green
ORG	Orange
PPL	Purple
RED	Red
WHT	White
YLW	Yellow

14.6.2 Wiring diagram: Indoor unit

See the internal wiring diagram supplied with the unit (on the inside of the indoor unit switch box cover). The abbreviations used are listed below.

Position in switch box

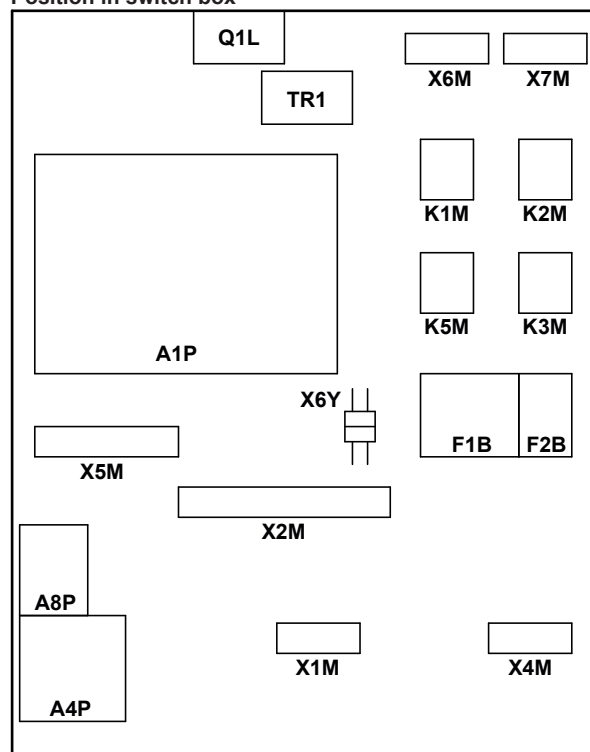

Backup heater configuration (only for *9W):

- 3V3 (1N~, 230 V, 3 kW)
- 6V3 (1N~, 230 V, 6 kW)
- 6WN (3N~, 400 V, 6 kW)
- 9WN (3N~, 400 V, 9 kW)
- 6T1 (3~, 230 V, 6 kW)

User installed options:

- Bottom plate heater
- Domestic hot water tank
- Domestic hot water tank with solar connection
- Remote user interface
- External indoor thermistor
- External outdoor thermistor
- Digital I/O PCB
- Demand PCB
- Solar pump and control station

Main leaving water temperature:

- On/OFF thermostat (wired)
- On/OFF thermostat (wireless)
- External thermistor on On/OFF thermostat (wireless)
- Heat pump convector

Additional leaving water temperature:

- On/OFF thermostat (wired)
- On/OFF thermostat (wireless)
- External thermistor on On/OFF thermostat (wireless)
- Heat pump convector

14 Technical data

only for *KHWE*Z2

only for *KHWS*Z2

only for *KHWE*V3

only for *KHWS*V3

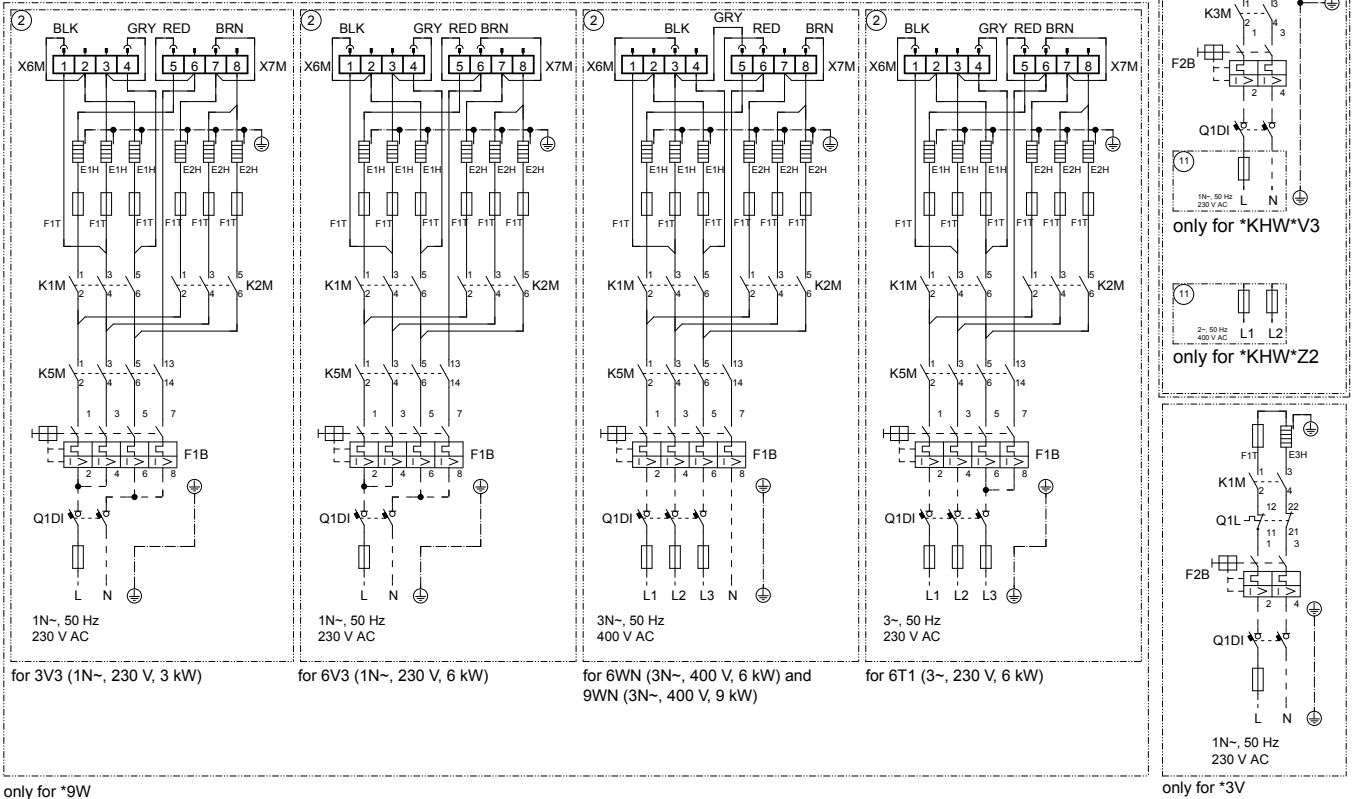
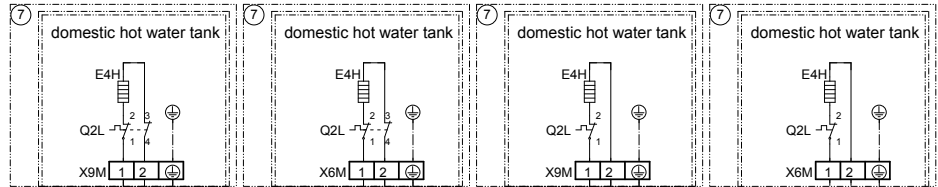

14 Technical data

A3P	*	Solar pump station PCB
A3P	*	On/OFF thermostat (PC=power circuit)
A3P	*	Heat pump convector
A4P	*	Digital I/O PCB
A4P	*	Receiver PCB (Wireless On/OFF thermostat)
A8P	*	Demand PCB
B1L		Flow sensor
BSK	*	Solar pump station relay
DS1(A8P)	*	DIP switch
E1H		Backup heater element (1 kW)
E2H		Backup heater element (2 kW)
E3H		Backup heater element (3 kW)
E4H	*	Booster heater (3 kW)
F1B		Overcurrent fuse backup heater
F2B	*	Overcurrent fuse booster heater
F1T		Thermal fuse backup heater
F1U, F2U	*	Fuse 5 A 250 V for digital I/O PCB
FU1		Fuse T 6.3 A 250 V for PCB
PHC1	*	Optocoupler input circuit
K1M, K2M		Contacteur backup heater
K3M	*	Contacteur booster heater
K5M		Safety contacteur backup heater (only for *9W)
K*R		Relay on PCB
M1P		Main supply pump
M2P	#	Domestic hot water pump
M2S	#	2-way valve for cooling mode
M3S	(*)	3-way valve for floor heating/domestic hot water
Q1DI, Q2DI	#	Earth leakage circuit breaker
Q1L		Thermal protector backup heater
Q2L	*	Thermal protector booster heater
R1T		Outlet water heat exchanger thermistor
R1T (A2P)		Ambient sensor user interface
R1T (A3P)	*	Ambient sensor On/OFF thermostat
R2T		Outlet backup heater thermistor
R2T	*	External sensor (floor or ambient)
R3T		Refrigerant liquid side thermistor
R4T		Inlet water thermistor
R5T	(*)	Domestic hot water thermistor
R6T	*	External indoor or outdoor ambient thermistor
R1H (A3P)	*	Humidity sensor
S1S	#	Preferential kWh rate power supply contact
S2S	#	Electrical meter pulse input 1
S3S	#	Electrical meter pulse input 2
S6S~S9S	#	Digital power limitation inputs
SS1 (A4P)	*	Selector switch
TR1		Power supply transformer
X*M		Terminal strip
X*Y		Connector

* = Optional
 (*) = Standard for EHVH/X, optional for EHBH/X
 # = Field supply

BLK	Black
BRN	Brown
GRY	Grey
RED	Red

Notes to go through before starting the unit

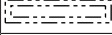
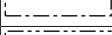
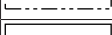
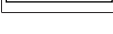
English	Translation
X1M	Main terminal
X2M	Field wiring terminal for AC
X5M	Field wiring terminal for DC
X6M, X7M	Backup heater terminal
X4M	Booster heater terminal
-----	Earth wiring
15	Wire number 15
-----	Field supply
→ **/12.2	Connection ** continues on page 12 column 2
①	Several wiring possibilities
	Option
	Not mounted in switch box
	Wiring depending on model
	PCB

Electrical connection diagram

For more details, please check the unit wiring.

Power supply

STANDARD PART

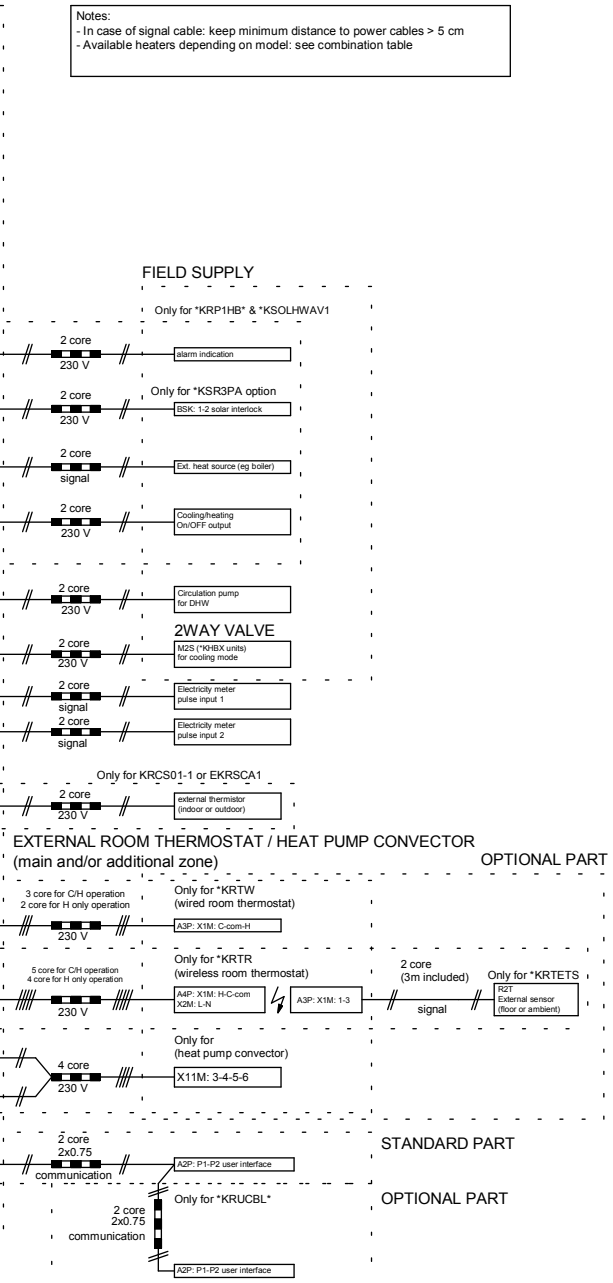
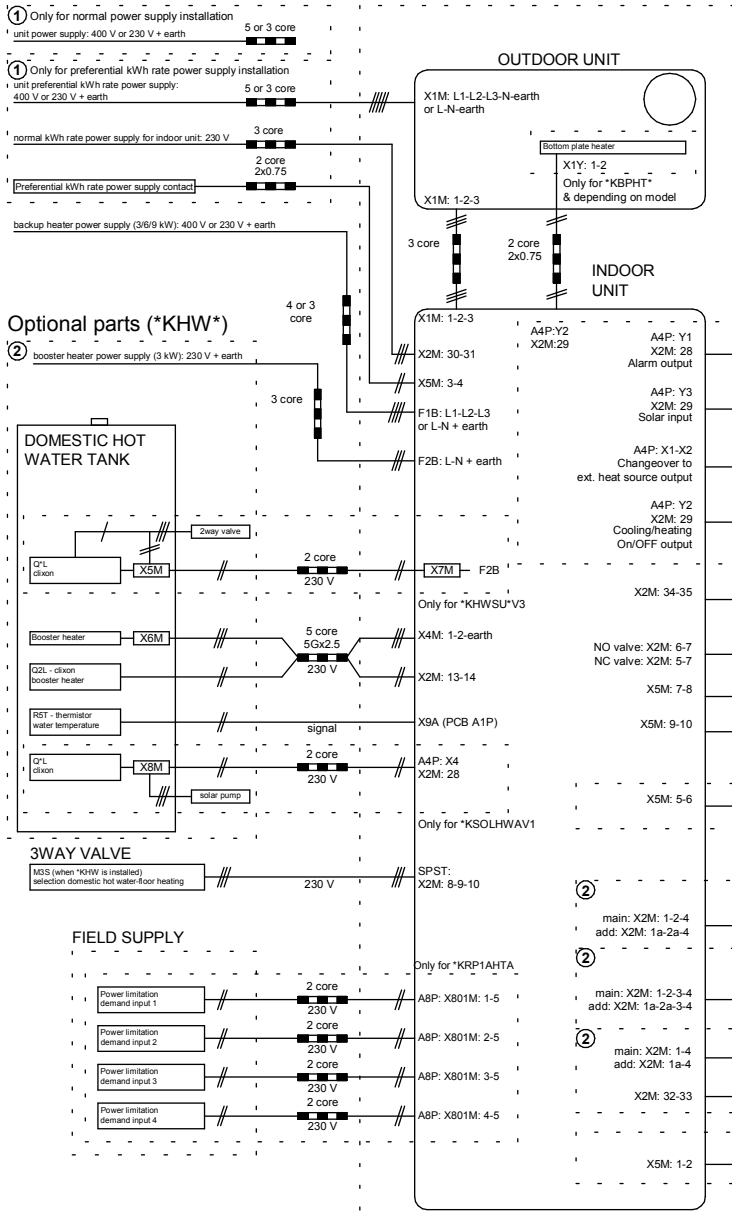

4D090420

14 Technical data

* electrical meter specification

- pulse meter type/voltage free contact for 5 VDC detection by PCB
- possible number of pulse:
 - 0.1 pulse/kWh
 - 1pulse/kWh
 - 10pulse/kWh
 - 100 pulse/kWh
 - 1000 pulse/kWh
- pulse duration:
 - minimum On time 40ms
 - minimum OFF time 100ms
- measurement type (depending on installation):
 - single phase AC meter
 - three phase AC meter (balanced loads)
 - three phase AC meter (unbalanced loads)

* electrical meter installation guideline

- General: it is the responsibility of the installer to cover the complete power consumption with electrical meters (combination of estimation and metering is not allowed)
- Required number of electrical meters:

Outdoor unit type		*RLQ(04/06/08)*			*R*Q(011/014/016)*V3			*R*Q(011/014/016)*W1					
Indoor unit type		*HB(H/X)(04/08)C*			*HB(H/X)16C*			*HB(H/X)16C*					
Backup heater type (#)	3V / 9W	9W	9W	3V / 9W	9W	9W	3V / 9W	9W	9W				
	1~ 230V	3~ 400V	3~ 230V	1~ 230V	3~ 400V	3~ 230V	1~ 230V	3~ 400V	3~ 230V				
	3 / 6 kW	6 / 9 kW	6 kW	3 / 6 kW	6 / 9 kW	6 kW	3 / 6 kW	6 / 9 kW	6 kW				
Regular kWh rate power supply													
Electrical meter type	1~	1	1	-	-	1	1	-	-	1	-	1	-
	3~ balanced	-	1	-	-	-	1	-	-	1	-	1	-
	3~ unbalanced	-	-	1	1	-	-	1	1	-	1	-	1
Benefit kWh rate power supply													
Electrical meter type	1~	2	1	1	2	1	1	1	-	-	-	-	
	3~ balanced	-	-	-	-	-	-	1	1	1	1	1	
	3~ unbalanced	-	1	1	-	1	1	-	1	1	1	1	

4D078288-B

14.7 Technical specifications

14.7.1 Technical specifications: Outdoor unit

Nominal capacity and nominal input

		Heating only type			Reversible type		
Outdoor units		ERLQ004CAV 3	ERLQ006CAV 3	ERLQ008CAV 3	ERLQ004CAV 3	ERLQ006CAV 3	ERLQ008CAV 3
Indoor units		EHBH04	EHBH08		EHBX04	EHBX08	
		EHVH04	EHVH08		EHVX04	EHVX08	
Condition 1^(a)							
Heating capacity	Minimum	1.80 kW					
	Nominal	4.40 kW	6.00 kW	7.40 kW	4.40 kW	6.00 kW	7.40 kW
	Maximum	5.12 kW	8.35 kW	10.02 kW	5.12 kW	8.35 kW	10.02 kW
Cooling capacity	Minimum	—			2.00 kW	2.50 kW	
	Nominal	—			5.00 kW	6.76 kW	6.86 kW
	Maximum	—					
Heating PI	Nominal	0.87 kW	1.27 kW	1.66 kW	0.87 kW	1.27 kW	1.66 kW
Cooling PI	Nominal	—			1.48 kW	1.96 kW	2.01 kW
COP	Nominal	5.04	4.74	4.45	5.04	4.74	4.45
EER	Nominal	—			3.37	3.45	3.42
Condition 2^(b)							
Heating capacity	Minimum	1.80 kW					
	Nominal	4.03 kW	5.67 kW	6.89 kW	4.03 kW	5.67 kW	6.89 kW
	Maximum	4.90 kW	7.95 kW	9.53 kW	4.90 kW	7.95 kW	9.53 kW
Cooling capacity	Minimum	—			2.00 kW	2.50 kW	
	Nominal	—			4.17 kW	4.84 kW	5.36 kW
	Maximum	—					
Heating PI	Nominal	1.13 kW	1.59 kW	2.01 kW	1.13 kW	1.59 kW	2.01 kW
Cooling PI	Nominal	—			1.80 kW	2.07 kW	2.34 kW
COP	Nominal	3.58	3.56	3.42	3.58	3.56	3.42
EER	Nominal	—			2.32	2.34	2.29

(a) In heating: Ambient temperature DB/WB 7°C/6°C – leaving water condenser 35°C (DT=5°C). In cooling: Ambient temperature 35°C – leaving water evaporator 18°C (DT=5°C)

(b) In heating: Ambient temperature DB/WB 7°C/6°C – leaving water condenser 45°C (DT=5°C). In cooling: Ambient temperature 35°C – leaving water evaporator 7°C (DT=5°C)

Technical specifications

Outdoor units	ERLQ004CAV3	ERLQ006CAV3	ERLQ008CAV3
Casing			
Colour	Ivory white		
Material	Polyester painted galvanised steel		
Dimensions			
Packing (H×W×D)	797×990×390 mm		
Unit (H×W×D)	735×832×307 mm		
Weight			
Machine weight	54 kg	56 kg	
Gross weight	57 kg	59 kg	
Packing			
Material	EPS, carton		
Weight	3 kg		
Heat exchanger			

14 Technical data

Outdoor units		ERLQ004CAV3	ERLQ006CAV3	ERLQ008CAV3
Specifications	Length	845 mm		
	Nr. of rows	2		
	Fin pitch	1.8 mm		
	Nr. of passes	—		
	Face area	—		
	Nr. of stages	32		
Tube type	Ø8 Hi-Xa			
Fin	Type	WF fin		
	Treatment	Anti-corrosion treatment		
Fan				
Type	Propeller fan			
Quantity	1			
Air flow rate (nominal at 230 V)	Heating	45 m³/min	47 m³/min	
	Cooling	52.5 m³/min		
Discharge direction	Horizontal			
Motor	Quantity	1		
	Output	53 W		
Compressor				
Quantity	1			
Motor	Model	2YC36BXD#C	2YC45DXD#C	
	Type	Hermetically sealed swing compressor		
	Output	—		
PED				
Category of unit	I (excluded from scope of PED due to article 1, item 3.6 of 97/23/EC)			
Operation range ⁽¹⁾				
Heating (outdoor unit)*	Minimum	-25°C DB		
	Maximum	25°C DB		
Cooling (outdoor unit)	Minimum	10°C DB		
	Maximum	43°C DB		
Domestic hot water (outdoor unit)**	Minimum	-25°C DB		
	Maximum	35°C DB		
Sound level				
Nominal - Heating	Sound power	61 dBA	62 dBA	
	Sound pressure ⁽²⁾	48 dBA	49 dBA	
Nominal - Cooling	Sound power	63 dBA		
	Sound pressure ⁽²⁾	48 dBA	49 dBA	50 dBA
Night quiet	Sound pressure	—		
Refrigerant				
Type	R410A			
Charge	1.45 kg	1.60 kg		
Control	Expansion valve (electronic type)			
Nr. of circuits	1			
Refrigerant oil				
Type	FVC50K			
Charged volume	0.75 l			
Piping connections				
Liquid	Type	Flare connection		
	Diameter (OD)	Ø6.35 mm		
Gas	Type	Flare connection		
	Diameter (OD)	Ø15.9 mm		

(1) See operation range drawing. *Range increase by support backup heater. **Range increase by support booster heater or backup heater.

(2) The sound pressure level is measured via a microphone at a certain distance from the unit. It is a relative value depending on the distance and acoustic environment. Refer to the sound spectrum drawing for more information.

Outdoor units		ERLQ004CAV3	ERLQ006CAV3	ERLQ008CAV3
Drain	Quantity	2		
	Type	Hole		
	Diameter (OD)	1× Ø15 mm + 1× Ø20 mm		
Piping length	Minimum	3 m		
	Maximum	30 m		
	Equivalent	—		
	Chargeless	10 m		
Additional refrigerant charge		0.02 kg/m IF >10 m		
Maximum height difference between outdoor unit and indoor unit		20 m		
Defrost method		Reverse cycle		
Defrost control		Sensor for outdoor heat exchanger temperature		
Capacity control method		Inverter controlled		

Electrical specifications

		ERLQ004-008CAV3	
Power supply			
Name	V3		
Phase	1		
Frequency	50 Hz		
Voltage	230 V		
Voltage range	Minimum	-10%	
	Maximum	+10%	
Current			
Nominal running current	Cooling	—	
	Heating	—	
Starting current	Cooling	15.7 A	18 A ⁽³⁾
	Heating	—	
Maximum running current	Cooling	15.7 A	18 A ⁽³⁾
	Heating	—	
Z _{max}	—		
Minimum S _{sc} value	Equipment complying with EN/IEC 61000-3-12 ⁽⁴⁾		
Recommended fuses	16 A		20 A
Wiring connections			
For power supply	Quantity	3	
	Remark	—	
For connection with indoor	Quantity	3	
	Remark	No earth wire	

Figure A: Starting current

Daikin inverter controlled compressor starting current always less than or equal to maximal running current.

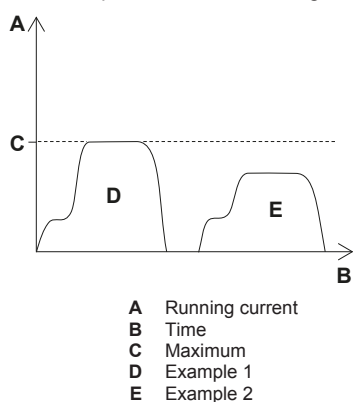

Standard on/off compressor starting current to maximum running current

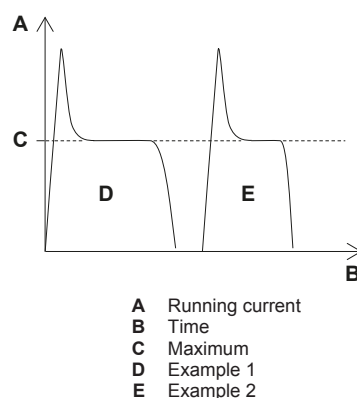

(3) See figure A.

(4) European/International Technical Standard setting the limits for harmonic currents produced by equipment connected to public low-voltage systems with input current >16 A and ≤75 A per phase.

14 Technical data

14.7.2 Technical specifications: Indoor unit

Technical specifications

Indoor units		EHBH04CB3V	EHBH08CB3V	EHBH08CB9W	EHBX04CB3V	EHBX08CB3V	EHBX08CB9W
Nominal input (indoor unit only)		75 W					
Casing							
Colour		White					
Material		Pre-coated sheetmetal					
Dimensions							
Packing (H×W×D)		890×480×344 mm					
Unit (H×W×D)		415×650×1016 mm					
Weight of machine (net)		41 kg	43 kg	45 kg	42 kg	44 kg	45 kg
Weight of machine (packed)		45 kg	46 kg	48 kg	45 kg	47 kg	48 kg
Packing materials							
Material		EPS – carton – PP (straps)					
Weight		3 kg					
PED							
Category of unit		Art. 3.3§3 ⁽¹⁾	Category I ⁽¹⁾		Art 3.3§3 ⁽¹⁾	Category I ⁽¹⁾	
Most critical part		—	Plate heat exchanger		—	Plate heat exchanger	
	Ps*V	—	51 bar		—	51 bar	
Pump							
Type		DC motor					
Nr. of speed		Inverter controlled					
Power input		45 W					
Water side heat exchanger							
Type		Braze plated					
Quantity		1					
Water volume		0.9 l	1.3 l		0.9 l	1.3 l	
Water flow rate	Minimum	13 l/min ⁽²⁾					
	Maximum	13 l/min	21.5 l/min		13 l/min	21.5 l/min	
Expansion vessel	Volume	10 l					
	Maximum water pressure	3 bar					
	Pre-pressure	1 bar					
Water filter	Diameter perforations	1					
	Material	Copper + brass + stainless steel					
Water circuit							
Piping connections Ø		G 1-1/4 female					
Safety valve		3 bar					
Manometer		Yes					
Drain valve/fill valve		Yes					
Shut-off valves		Yes					
Air purge valve		Yes					
Total water volume		3 l ⁽³⁾	4.0 l ⁽³⁾		3.0 l ⁽³⁾	4.0 l ⁽³⁾	
Refrigerant circuit							
Gas side		Ø15.9 mm					
Liquid side		Ø6.4 mm					
Sound power level							
Nominal		40 dBA ⁽⁴⁾					
Sound pressure level							
Nominal		26 dBA ⁽⁵⁾					
Operation range							

Indoor units		EHBH04CB3V	EHBH08CB3V	EHBH08CB9W	EHBX04CB3V	EHBX08CB3V	EHBX08CB9W
Heating	Heating at water side	Maximally 55°C					
	Indoor installation	5~35°C DB					
	Domestic hot water at water side	80°C ⁽⁶⁾					
Safety devices		Thermal cut out					

Electrical specifications

		EHBH04CB3V	EHBH08CB3V	EHBH08CB9W	EHBX04CB3V	EHBX08CB3V	EHBX08CB9W
Power supply	Name	See ⁽⁷⁾					
	Voltage range	-10%~+10%					
Wiring connections							
For power supply backup heater	Quantity of wires	3G		Refer to installation manual		3G	Refer to installation manual
	Type of wires	See ⁽⁶⁾					
Communication cable to outdoor unit	Quantity of wires	3					
	Type of wires	2.5 mm ²					
Preferential kWh rate power supply	Quantity of wires	Power: 2					
	Type of wires	Power: 6.3 A ⁽⁹⁾					
Electricity meter	Quantity of wires	2					
	Type of wires	Minimum 0.75 mm ² (5 V DC pulse detection)					
Domestic hot water pump	Quantity of wires	2					
	Type of wires	Minimum 0.75 mm ² (2 A in rush, 1 A continuous)					
For power supply connection to optional EKHW	Quantity	3G					
	Type of wires	13 A ⁽⁸⁾					
For connection to optional model EKHW + Q2L	Quantity	5G					
	Type of wires	For more details of the voltage range and current, refer to installation manual. ⁽⁸⁾					
For connection with R5T	Quantity	Wire included in option EKHW					
For connection with R6T	Quantity of wires	2					
	Type of wires	Minimum 0.75 mm ²					
For connection with A3P	Quantity of wires	Depends on thermostat type					
	Type of wires	Voltage 230 V/maximum current: 100 mA/minimum 0.75 mm ² . ⁽⁸⁾					
For connection with M2S	Quantity of wires	2					
	Type of wires	Voltage 230 V/maximum current: 100 mA/minimum 0.75 mm ² . ⁽⁸⁾					
For connection with M3S	Quantity of wires	3					
	Type of wires	Voltage 230 V/maximum current: 100 mA/minimum 0.75 mm ² . ⁽⁸⁾					
For connection with bottom plate heater	Quantity of wires	2					
	Type of wires	Voltage 230 V/maximum current: 100 mA/minimum 0.75 mm ² . ⁽⁸⁾					
For connection with user interface	Quantity of wires	2					
	Type of wires	0.75 mm ² ~1.25 mm ² (maximum length 500 m)					
For connection with optional FWXV (demand input and output)	Quantity of wires	4					
	Type of wires	100 mA, minimum 0.75 mm ²					

- (1) PED unit category: excluded from scope of PED due to article 1, item 3.6 of 97/23/EC.
- (2) Operation area is extended to lower flow rates only in case the unit operated with heat pump only. (Not in startup, no backup heater operation, no defrost operation).
- (3) Including piping + PHE + backup heater; excluding expansion vessel.
- (4) DB/WB 7°C/6°C – LWC 35°C (DT=5°C)
- (5) The sound pressure level is measured in an anechoic room at 1 m distance from the unit. It is a relative value, depending on the distance and acoustic environment. The sound pressure level mentioned is maximum possible value inside operation range of unit.
- (6) >50°C BSH only, no heat pump operation.
- (7) Above mentioned power supply of the hydrobox is for the backup heater only. The switch box and the pump of the hydrobox are supplied via the outdoor unit. The optional domestic hot water tank has a separate power supply.
- (8) Select diameter and type according to national and local regulations.
- (9) Select diameter and type according to national and local regulations. Equipment complying with EN/IEC 61000-3-12: European/technical standard setting the limits for harmonic currents produced by equipment connected to public low-voltage system with input >16 A and ≤75 A per phase.

14 Technical data

(10) Above mentioned power supply of the hydrobox is for the backup heater only. The switch box and the pump of the hydrobox are supplied via the outdoor unit. The optional domestic hot water tank has a separate power supply.

Electrical specifications of backup heater and booster heater (only for EKHW)

Type	3V		9W				
Backup heater							
Capacity setting	3 kW	6 kW	3 kW	6 kW	9 kW		
Capacity stage	1	2	1	2			
Capacity stage 1	3 kW						
Capacity stage 2	—	6	—	6	9		
Minimum delay between stages	See figure 1		See figure 2				
Power supply ⁽¹⁾	1~ 50 Hz	3~ 50 Hz	1~ 50 Hz		3~ 50 Hz		
Voltage	230 V				400 V		
Nominal current	13 A	15.1 A	13 A	26 A	8.7 A	13 A	
Z _{max} (backup heater) ⁽²⁾	—						
Minimum S _{sc} value	—		(5)		—		
Booster heater (optional EKHW models)							
Capacity setting	3 kW						
Capacity stage	1						
Minimum time delay between stages	See figure 3						
Nominal current	V3	26 (13+13) A	28.1 (15.1+13) A	26 (13+13) A	39 (26+13) A	21.7 (8.7+13) A	26 (13+13) A
	Z2	—				16.2 (8.7+7.5) A	20.5 (13+7.5) A
Minimum S _{sc} value	V3	(3)					
	Z2	—				(3)	

(1) The above mentioned power supply of the hydrobox is for the backup heater only. The switch box and the pump of the hydrobox are supplied with the outdoor unit. The optional domestic hot water tank has a separate power supply.

(2) In accordance with EN/IEC 61000-3-11, it may be necessary to consult the distribution network operator to ensure that the equipment is connected only to a supply Zsysnode:1261007898681260911529 ≤Zmaxnode:1261007898681260911528.

Figure 1: Backup heater (*3V), minimum time delay between stages

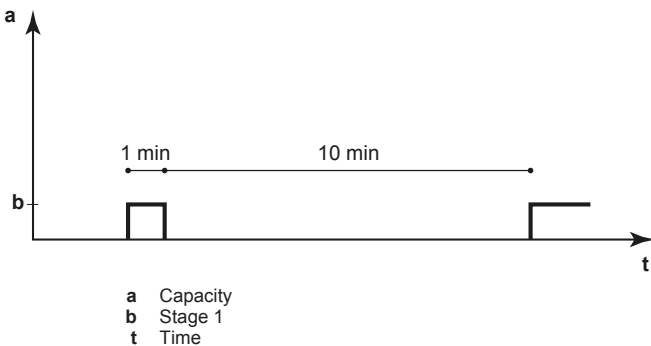

Figure 3: Booster heater (EKHW), minimum time delay between stages

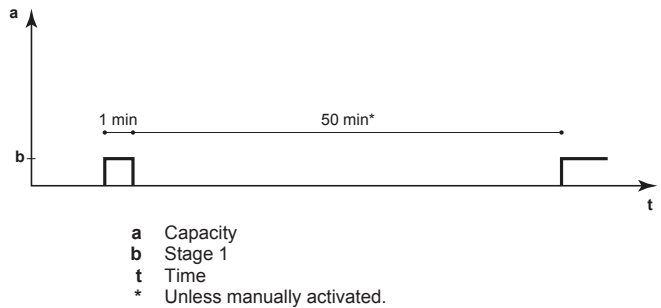
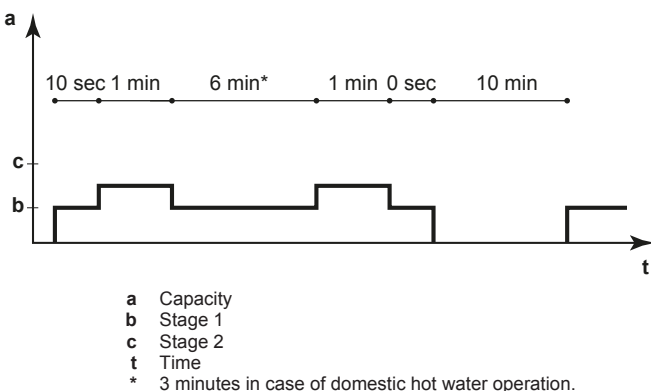

Figure 2: Backup heater (*9W), minimum time delay between stages



(5) The equipment complies with EN/IEC 61000-3-12.

14.8 Operation range

14.8.1 Operation range: Heating and cooling

Space heating and cooling mode (for current models in this manual)

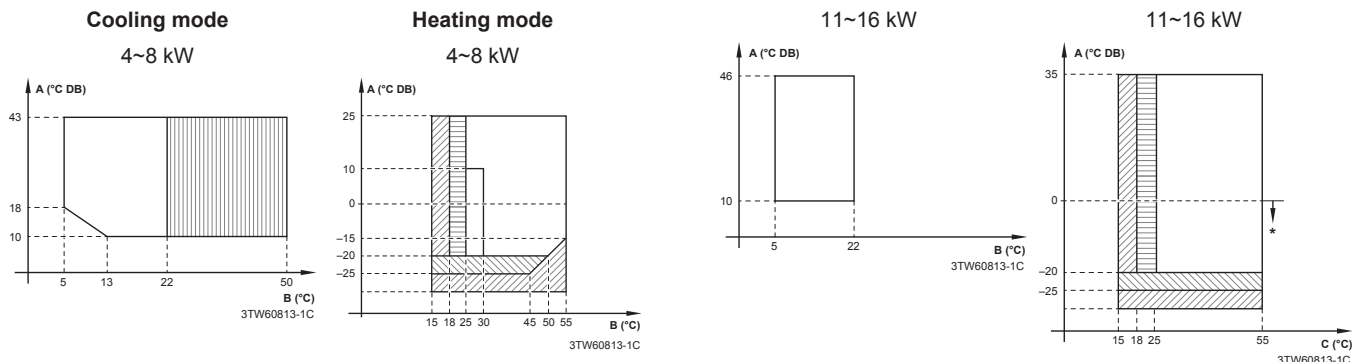

- A** Outdoor temperature
- B** Leaving water evaporator temperature
- C** Leaving water condenser temperature
- ▨ Backup heater only operation. No outdoor operation.
- ▨ Outdoor unit operation is possible if setpoint $\geq 25^{\circ}\text{C}$.
- ▨ Operation of outdoor unit is possible, but with possible capacity reduction. If the outdoor temperature $< -25^{\circ}\text{C}$, the outdoor unit will stop. Indoor unit and backup heater operation will continue.
- ▨ Pull-down area.

Remark: In restricted power supply mode, the outdoor unit, booster heater, and backup heater can only operate separately.

- (*) ERLQ units include special equipment (insulation, heater sheet,...) to ensure proper operation in areas with low ambient temperatures and high humidity conditions. In such conditions, the ERHQ models may experience problems with severe ice buildup on the air-cooled coil. If such conditions are expected, the ERLQ must be installed instead. These models contain countermeasures (insulation, heater sheet,...) to prevent freeze-up.

14 Technical data

14.8.2 Operation range: Domestic hot water

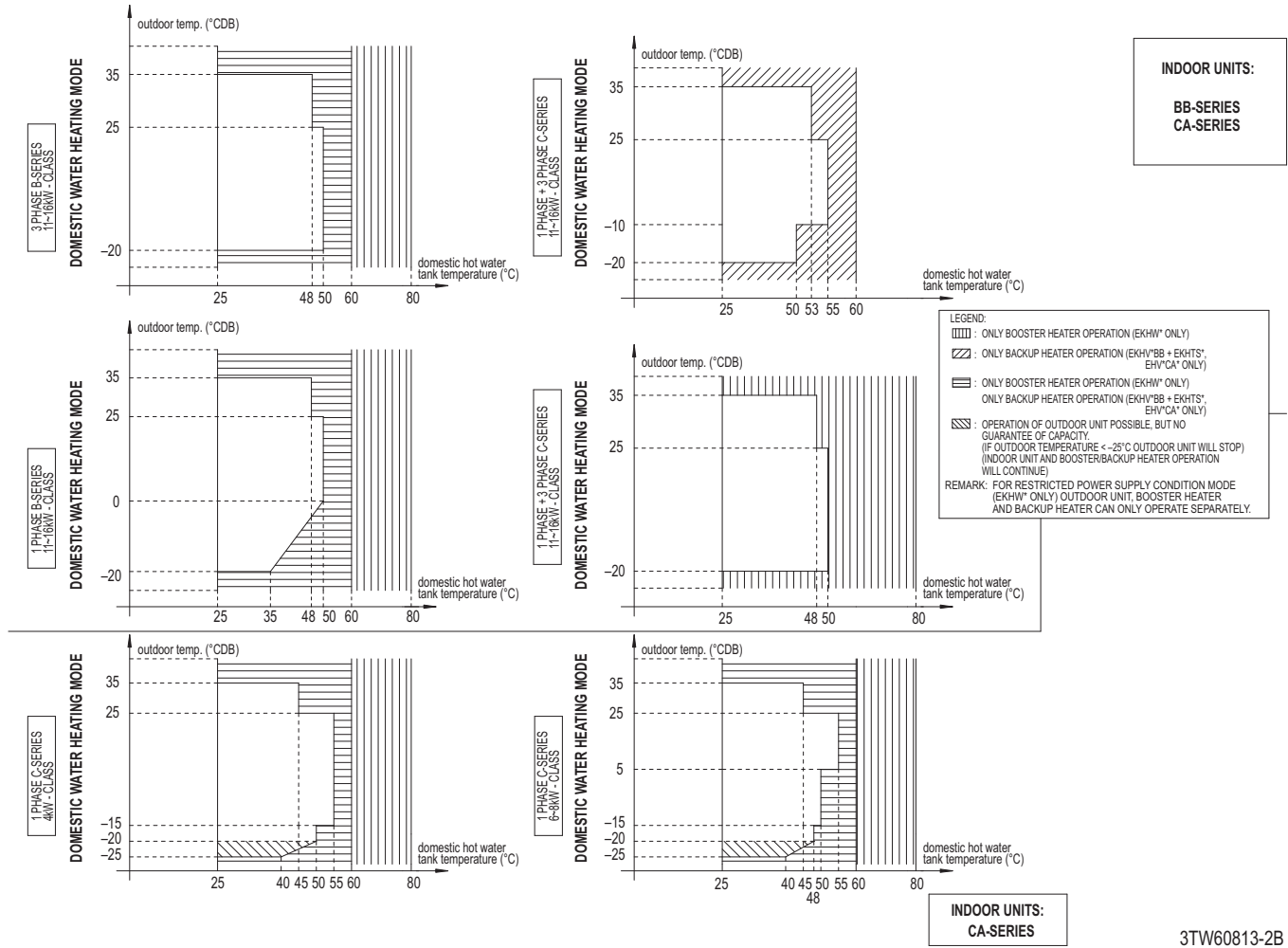

14.8.3 Drain pan necessity

Entering water temperature limit to prevent condensation

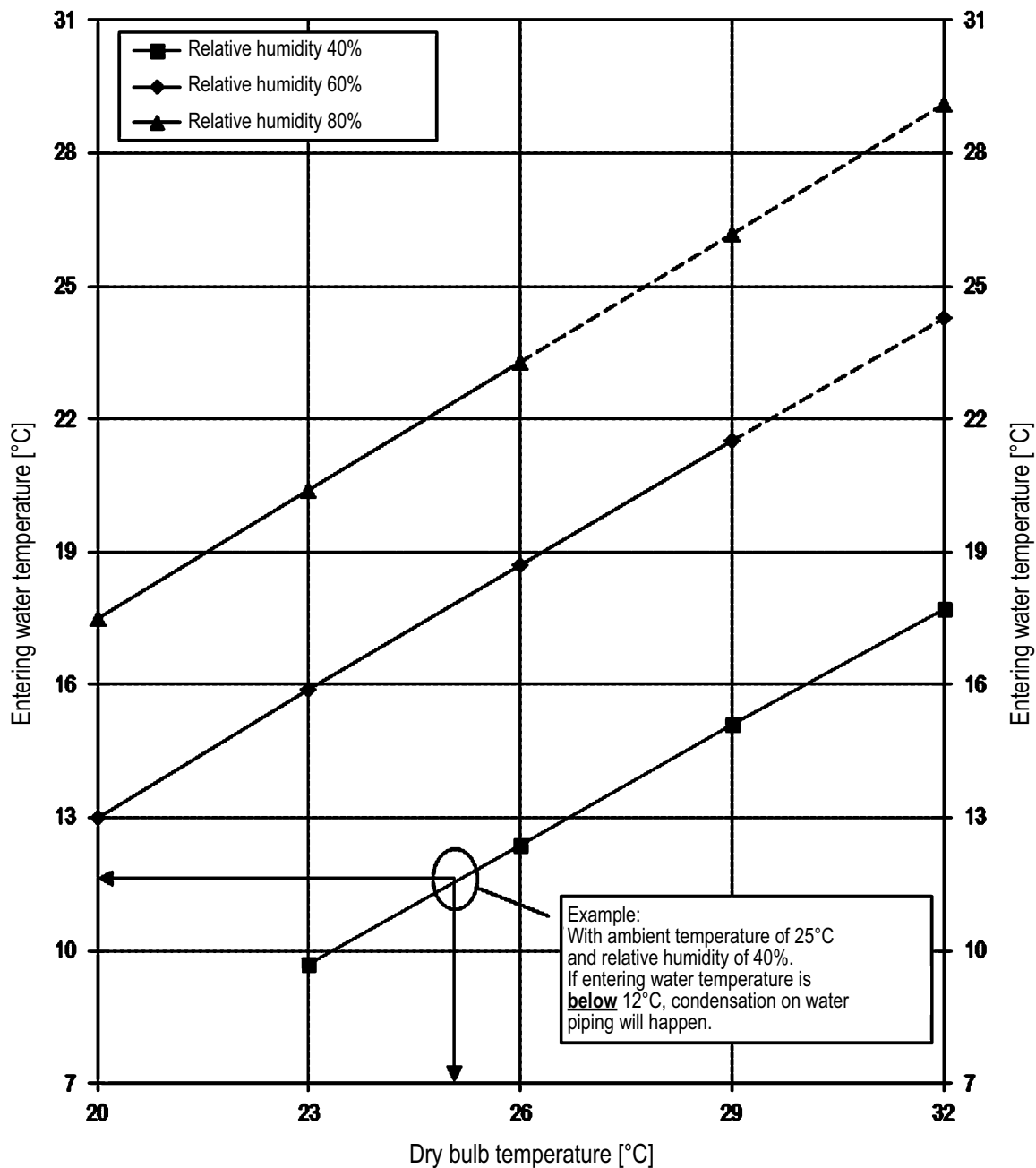

1. Refer to psychometric chart for more information.
2. If condensation is expected, installation of EKHB DPCA2 - drainpan kit must be considered.

4D078990

14 Technical data

14.9 ESP curve

14.9.1 ESP curve: Indoor unit

Note: A flow error will occur when the minimum water flow rate is not reached.

EHBH/X04=EHBH/X04

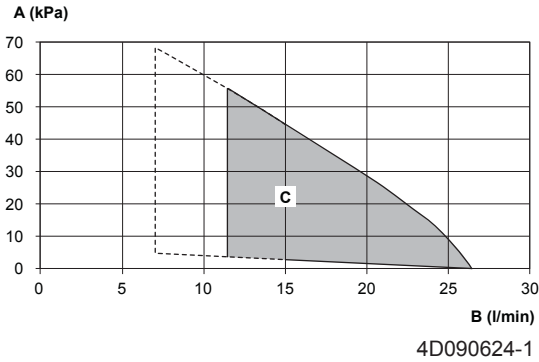

EHBH/X08=EHBH/X08

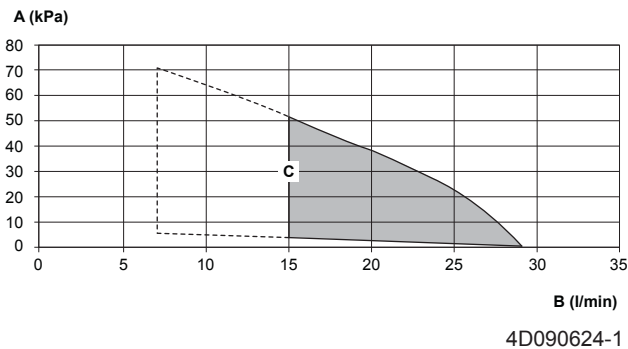

- A** External static pressure
- B** Water flow rate
- C** Operation range

Operation area is extended to lower flow rates only in case the unit operates with heat pump only. (Not in startup, no backup heater operation, no defrost operation).

ESP=External static pressure [kPa] in the space heating/cooling circuit.

Flow=Water flow through the unit in the space heating/cooling circuit.

Notes:

- Selecting a flow outside the area of operation can cause damage or malfunction of the unit. See also the minimum and maximum allowed water flow range in the technical specifications.
- Water quality MUST be according to EN directive EC98/83EC.

15 Glossary

Dealer

Sales distributor for the product.

Authorized installer

Technical skilled person who is qualified to install the product.

User

Person who is owner of the product and/or operates the product.

Applicable legislation

All international, European, national and local directives, laws, regulations and/or codes that are relevant and applicable for a certain product or domain.

Service company

Qualified company which can perform or coordinate the required service to the product.

Installation manual

Instruction manual specified for a certain product or application, explaining how to install, configure and maintain it.

Operation manual

Instruction manual specified for a certain product or application, explaining how to operate it.

Accessories

Labels, manuals, information sheets and equipment that are delivered with the product and that need to be installed according to the instructions in the accompanying documentation.

Optional equipment

Equipment made or approved by Daikin that can be combined with the product according to the instructions in the accompanying documentation.

Field supply

Equipment not made by Daikin that can be combined with the product according to the instructions in the accompanying documentation.

Field settings table

Applicable indoor units

*HBH04CB3V	*HVH04S18CB3V
*HBH08CB3V	*HVH08S18CB3V
*HBH11CB3V	*HVH11S18CB3V
*HBH16CB3V	*HVH16S18CB3V
*HBX04CB3V	*HVX04S18CB3V
*HBX08CB3V	*HVX08S18CB3V
*HBX11CB3V	*HVX11S18CB3V
*HBX16CB3V	*HVX16S18CB3V
*HBH08CB9W	*HVH08S26CB9W
*HBH11CB9W	*HVH11S26CB9W
*HBH16CB9W	*HVH16S26CB9W
*HBX08CB9W	*HVX08S26CB9W
*HBX11CB9W	*HVX11S26CB9W
*HBX16CB9W	*HVX16S26CB9W

Notes

- (*1) *HB*
- (*2) *HV*
- (*3) *3V
- (*4) *9W
- (*5) *04/08*
- (*6) *11/16*

Field settings table					Installer setting at variance with default value	
Breadcrumb	Field code	Setting name	Range, step	Default value	Date	Value
User settings						
└ Preset values						
└ Room temperature						
7.4.1.1		Comfort (heating)	R/W	[3-07]~[3-06], step: A.3.2.4 21°C		
7.4.1.2		Eco (heating)	R/W	[3-07]~[3-06], step: A.3.2.4 19°C		
7.4.1.3		Comfort (cooling)	R/W	[3-08]~[3-09], step: A.3.2.4 24°C		
7.4.1.4		Eco (cooling)	R/W	[3-08]~[3-09], step: A.3.2.4 26°C		
└ LWT main						
7.4.2.1	[8-09]	Comfort (heating)	R/W	[9-01]~[9-00], step: 1°C 35°C		
7.4.2.2	[8-0A]	Eco (heating)	R/W	[9-01]~[9-00], step: 1°C 33°C		
7.4.2.3	[8-07]	Comfort (cooling)	R/W	[9-03]~[9-02], step: 1°C 18°C		
7.4.2.4	[8-08]	Eco (cooling)	R/W	[9-03]~[9-02], step: 1°C 20°C		
7.4.2.5		Comfort (heating)	R/W	-10~10°C, step: 1°C 0°C		
7.4.2.6		Eco (heating)	R/W	-10~10°C, step: 1°C -2°C		
7.4.2.7		Comfort (cooling)	R/W	-10~10°C, step: 1°C 0°C		
7.4.2.8		Eco (cooling)	R/W	-10~10°C, step: 1°C 2°C		
└ Tank temperature						
7.4.3.1	[6-0A]	Storage comfort	R/W	30~[6-0E]°C, step: 1°C 60°C		
7.4.3.2	[6-0B]	Storage eco	R/W	30~min(50, [6-0E])°C, step: 1°C 45°C		
7.4.3.3	[6-0C]	Reheat	R/W	30~min(50, [6-0E])°C, step: 1°C 45°C		
└ Quiet level						
7.4.4			R/W	0: Level 1 1: Level 2 2: Level 3		
└ Electricity price						
7.4.5.1	[C-0C] [D-0C]	High	R/W	0,00~990/kWh 0/kWh		
7.4.5.2	[C-0D] [D-0D]	Medium	R/W	0,00~990/kWh 0/kWh		
7.4.5.3	[C-0E] [D-0E]	Low	R/W	0,00~990/kWh 0/kWh		
└ Fuel price						
7.4.6			R/W	0,00~990/kWh 0,00~290/MBtu 8,0/kWh		
└ Set weather dependent						
└ Main						
└ Set weather-dependent heating						
7.7.1.1	[1-00]	Set weather-dependent heating	R/W	Low ambient temp. for LWT main zone heating WD curve. -40~5°C, step: 1°C -10°C		
7.7.1.1	[1-01]	Set weather-dependent heating	R/W	High ambient temp. for LWT main zone heating WD curve. 10~25°C, step: 1°C 15°C		
7.7.1.1	[1-02]	Set weather-dependent heating	R/W	Leaving water value for low ambient temp. for LWT main zone heating WD curve. [9-01]~[9-00]°C, step: 1°C 35°C		
7.7.1.1	[1-03]	Set weather-dependent heating	R/W	Leaving water value for high ambient temp. for LWT main zone heating WD curve. [9-01]~min(45, [9-00])°C, step: 1°C 25°C		
└ Set weather-dependent cooling						
7.7.1.2	[1-06]	Set weather-dependent cooling	R/W	Low ambient temp. for LWT main zone cooling WD curve. 10~25°C, step: 1°C 20°C		
7.7.1.2	[1-07]	Set weather-dependent cooling	R/W	High ambient temp. for LWT main zone cooling WD curve. 25~43°C, step: 1°C 35°C		
7.7.1.2	[1-08]	Set weather-dependent cooling	R/W	Leaving water value for low ambient temp. for LWT main zone cooling WD curve. [9-03]~[9-02]°C, step: 1°C 22°C		
7.7.1.2	[1-09]	Set weather-dependent cooling	R/W	Leaving water value for high ambient temp. for LWT main zone cooling WD curve. [9-03]~[9-02]°C, step: 1°C 18°C		
└ Additional						
└ Set weather-dependent heating						
7.7.2.1	[0-00]	Set weather-dependent heating	R/W	Leaving water value for high ambient temp. for LWT add zone heating WD curve. [9-05]~min(45, [9-06])°C, step: 1°C 35°C		
7.7.2.1	[0-01]	Set weather-dependent heating	R/W	Leaving water value for low ambient temp. for LWT add zone heating WD curve. [9-05]~[9-06]°C, step: 1°C 45°C		
7.7.2.1	[0-02]	Set weather-dependent heating	R/W	High ambient temp. for LWT add zone heating WD curve. 10~25°C, step: 1°C 15°C		
7.7.2.1	[0-03]	Set weather-dependent heating	R/W	Low ambient temp. for LWT add zone heating WD curve. -40~5°C, step: 1°C -10°C		
└ Set weather-dependent cooling						
7.7.2.2	[0-04]	Set weather-dependent cooling	R/W	Leaving water value for high ambient temp. for LWT add zone cooling WD curve. [9-07]~[9-08]°C, step: 1°C 8°C		
7.7.2.2	[0-05]	Set weather-dependent cooling	R/W	Leaving water value for low ambient temp. for LWT add zone cooling WD curve. [9-07]~[9-08]°C, step: 1°C 12°C		
7.7.2.2	[0-06]	Set weather-dependent cooling	R/W	High ambient temp. for LWT add zone cooling WD curve. 25~43°C, step: 1°C 35°C		
7.7.2.2	[0-07]	Set weather-dependent cooling	R/W	Low ambient temp. for LWT add zone cooling WD curve. 10~25°C, step: 1°C 20°C		
Installer settings						
└ System layout						
└ Standard						
A.2.1.1	[E-00]	Unit type	R/O	0~5 0: LT split		
A.2.1.2	[E-01]	Compressor type	R/O	0: 8 1: 16		
A.2.1.3	[E-02]	Indoor software type	R/O	0: Type 1 1: Type 2		
A.2.1.4	[E-03]	Backup heater steps	R/O	0: No BUH 1: 1 step 2: 2 steps		

(*1) *HB* (*2) *HV*
 (*3) *3V* (*4) *9W*
 (*5) *04/08*
 (*6) *11/16*

Field settings table				Installer setting at variance with default value			
Breadcrumb	Field code	Setting name		Range, step	Date	Value	
				Default value			
A.2.1.5	[5-0D]	BUH type		R/W	0: 1P (1/2) 1: 1P, (1/1+2) 2: 3P, (1/2) 3: 3P, (1/1+2) (*3) 4: 3PN, (1/2) 5: 3PN, (1/1+2) (*4)		
A.2.1.6	[D-01]	Preferential kWh rate		R/W	0: No 1: Active open 2: Active closed		
A.2.1.7	[C-07]	Unit control method		R/W	0: LWT control 1: Ext RT control 2: RT control		
A.2.1.8	[7-02]	Number of LWT zones		R/W	0: 1 LWT zone 1: 2 LWT zones		
A.2.1.9	[F-0D]	Pump operation mode		R/W	0: Continuous 1: Sample 2: Request		
A.2.1.A	[E-04]	Power saving possible		R/O	0: No 1: Yes		
A.2.1.B		User interface location		R/W	0: At unit 1: In room		
Options							
A.2.2.1	[E-05]	DHW operation		R/W	0: No (*1) 1: Yes (*2)		
A.2.2.3	[E-07]	DHW tank type		R/W	0-6 0: Type 1 (*1) 1: Type 2 (*2)		
A.2.2.4	[C-05]	Contact type main		R/W	1: Thermo ON/OFF 2: C/H request		
A.2.2.5	[C-06]	Contact type add.		R/W	1: Thermo ON/OFF 2: C/H request		
A.2.2.6.1	[C-02]	Digital I/O PCB	Ext. backup heat src	R/W	0: No 1: Bivalent 2: - 3: -		
A.2.2.6.2	[D-07]	Digital I/O PCB	Solar kit	R/W	0: No 1: Yes		
A.2.2.6.3	[C-09]	Digital I/O PCB	Alarm output	R/W	0: Normally open 1: Normally closed		
A.2.2.6.4	[F-04]	Digital I/O PCB	Bottom plate heater	R/W	0: No 1: Yes		
A.2.2.7	[D-04]	Demand PCB		R/W	0: No 1: Pwr consmp ctrl		
A.2.2.8	[D-08]	External kWh meter 1		R/W	0: No 1: 0,1 pulse/kWh 2: 1 pulse/kWh 3: 10 pulse/kWh 4: 100 pulse/kWh 5: 1000 pulse/kWh		
A.2.2.9	[D-09]	External kWh meter 2		R/W	0: No 1: 0,1 pulse/kWh 2: 1 pulse/kWh 3: 10 pulse/kWh 4: 100 pulse/kWh 5: 1000 pulse/kWh		
A.2.2.A	[D-02]	DHW pump		R/W	0: No 1: Secondary rtm 2: Disinf. shunt		
A.2.2.B	[C-08]	External sensor		R/W	0: No 1: Outdoor sensor 2: Room sensor		
A.2.2.D	[E-0B]	Bi-zone kit	Is a bi-zone kit installed?	R/O	0: No (#)		
Capacities							
A.2.3.1	[6-02]	Booster heater		R/W	0-10kW, step: 0,2kW 0kW		
A.2.3.2	[6-03]	BUH: step 1		R/W	0-10kW, step: 0,2kW 3kW		
A.2.3.3	[6-04]	BUH: step 2		R/W	0-10kW, step: 0,2kW 0kW (*3) 6kW (*4)		
A.2.3.6	[6-07]	Bottom plate heater		R/W	0-200W, step: 10W 0W		
Space operation							
LWT settings							
Main							
A.3.1.1.1		LWT setpoint mode		R/W	0: Fixed 1: Weather dep. 2: Fixed + scheduled 3: WD + scheduled		
A.3.1.1.2.1	[9-01]	Temperature range	Minimum temp (heating)	R/W	15-37°C, step: 1°C 25°C		
A.3.1.1.2.2	[9-00]	Temperature range	Maximum temp (heating)	R/W	37-depending on outdoor unit, step: 1°C 55°C		
A.3.1.1.2.3	[9-03]	Temperature range	Minimum temp (cooling)	R/W	5-18°C, step: 1°C 5°C		
A.3.1.1.2.4	[9-02]	Temperature range	Maximum temp (cooling)	R/W	18-22°C, step: 1°C 22°C		
A.3.1.1.5	[8-05]	Modulated LWT		R/W	0: No 1: Yes		
A.3.1.1.6.1	[F-0B]	Shut-off valve	Thermo On/OFF	R/W	0: No 1: Yes		
A.3.1.1.6.2	[F-0C]	Shut-off valve	Cooling	R/W	0: No 1: Yes		
A.3.1.1.7	[9-0B]	Emitter type		R/W	0: Quick 1: Slow		
Additional							
A.3.1.2.1		LWT setpoint mode		R/W	0: Fixed 1: Weather dep. 2: Fixed + scheduled 3: WD + scheduled		
A.3.1.2.2.1	[9-05]	Temperature range	Minimum temp (heating)	R/W	15-37°C, step: 1°C 25°C		

(*1) *HB*_* (*2) *HV*_*
 (*3) *3V*_* (*4) *9W*_*
 (*5) *04/08*_*
 (*6) *11/16*_*

(#) Setting is not applicable for this unit.

Field settings table						Installer setting at variance with default value	
Breadcrumb	Field code	Setting name		Range, step	Default value	Date	Value
A.3.1.2.2.2	[9-06]	Temperature range	Maximum temp (heating)	R/W	37~depending on outdoor unit, step: 1°C 55°C		
A.3.1.2.2.3	[9-07]	Temperature range	Minimum temp (cooling)	R/W	5~18°C, step: 1°C 5°C		
A.3.1.2.2.4	[9-08]	Temperature range	Maximum temp (cooling)	R/W	18~22°C, step: 1°C 22°C		
Delta T source							
A.3.1.3.1	[9-09]	Heating		R/W	3~10°C, step: 1°C 5°C		
A.3.1.3.2	[9-0A]	Cooling		R/W	3~10°C, step: 1°C 5°C		
Room thermostat							
A.3.2.1.1	[3-07]	Room temp. range	Minimum temp (heating)	R/W	12~18°C, step: A.3.2.4 12°C		
A.3.2.1.2	[3-06]	Room temp. range	Maximum temp (heating)	R/W	18~30°C, step: A.3.2.4 30°C		
A.3.2.1.3	[3-09]	Room temp. range	Minimum temp (cooling)	R/W	15~25°C, step: A.3.2.4 15°C		
A.3.2.1.4	[3-08]	Room temp. range	Maximum temp (cooling)	R/W	25~35°C, step: A.3.2.4 35°C		
A.3.2.2	[2-0A]	Room temp. offset		R/W	-5~5°C, step: 0,5°C 0°C		
A.3.2.3	[2-09]	Ext. room sensor offset		R/W	-5~5°C, step: 0,5°C 0°C		
A.3.2.4		Room temp. step		R/W	0: 0,5 °C 1: 1 °C		
Operation range							
A.3.3.1	[4-02]	Space heating OFF temp		R/W	14~25°C, step: 1°C 25°C (*5) 14~35°C, step: 1°C 35°C (*6)		
A.3.3.2	[F-01]	Space cooling On temp		R/W	10~35°C, step: 1°C 20°C		
Domestic hot water (DHW)							
Type							
A.4.1	[6-0D]			R/W	0: Reheat only 1: Reheat + sched. 2: Scheduled only		
Disinfection							
A.4.4.1	[2-01]	Disinfection		R/W	0: No 1: Yes		
A.4.4.2	[2-00]	Operation day		R/W	0: Each day 1: Monday 2: Tuesday 3: Wednesday 4: Thursday 5: Friday 6: Saturday 7: Sunday		
A.4.4.3	[2-02]	Start time		R/W	0~23 hour, step: 1 hour 23		
A.4.4.4	[2-03]	Temperature target		R/W	[E-07]#1 : 55~80°C, step: 5°C 70°C [E-07]=1 : 60°C 60°C		
A.4.4.5	[2-04]	Duration		R/W	[E-07]#1 : 5~60 min, step: 5 min 10 min [E-07]=1 : 40~60 min, step: 5 min 40 min		
Maximum setpoint							
A.4.5	[6-0E]			R/W	[E-07]#1 : 40~80°C, step: 1°C 60°C [E-07]=1 : 40~60°C, step: 1°C 60°C		
SP mode							
A.4.6				R/W	0: Fixed 1: Weather dep.		
Weather dependent curve							
A.4.7	[0-0B]	Weather-dependent curve	Leaving water value for high ambient temp. for DHW WD curve.	R/W	35~[6-0E]°C, step: 1°C 50°C		
A.4.7	[0-0C]	Weather-dependent curve	Leaving water value for low ambient temp. for DHW WD curve.	R/W	45~[6-0E]°C, step: 1°C 60°C		
A.4.7	[0-0D]	Weather-dependent curve	High ambient temp. for DHW WD curve.	R/W	10~25°C, step: 1°C 15°C		
A.4.7	[0-0E]	Weather-dependent curve	Low ambient temp. for DHW WD curve.	R/W	-40~5°C, step: 1°C -10°C		
Heat sources							
Backup heater							
A.5.1.1	[4-00]	Operation mode		R/W	0: Disabled 1: Enabled 2: Only DHW		
A.5.1.2		Emergency		R/W	0: Manual 1: Automatic		
A.5.1.3	[4-07]	Enable BUH step 2		R/W	0: No 1: Yes		
A.5.1.4	[5-01]	Equilibrium temp.		R/W	-15~35°C, step: 1°C 0°C		
System operation							
Auto restart							
A.6.1	[3-00]			R/W	0: No 1: Yes		
Preferential kWh rate							
A.6.2.1	[D-00]	Allowed heaters		R/W	0: None 1: BSH only 2: BUH only 3: All heaters		
A.6.2.2	[D-05]	Forced pump OFF		R/W	0: Forced off 1: As normal		
Pwr consumpt. Control							
A.6.3.1	[4-08]	Mode		R/W	0: No limitation 1: Continuous 2: Digital inputs		

(*1) *HB* (*2) *HV*
 (*3) *3V* (*4) *9W*
 (*5) *04/08*
 (*6) *11/16*

Field settings table					Installer setting at variance with default value		
Breadcrumb	Field code	Setting name		Range, step	Default value	Date	Value
A.6.3.2	[4-09]	Type		R/W	0: Current 1: Power		
A.6.3.3	[5-05]	Amp. value		R/W	0-50 A, step: 1 A 50 A		
A.6.3.4	[5-09]	kW value		R/W	0-20 kW, step: 0.5 kW 20 kW		
A.6.3.5.1	[5-05]	Amp. limits for DI	Limit DI1	R/W	0-50 A, step: 1 A 50 A		
A.6.3.5.2	[5-06]	Amp. limits for DI	Limit DI2	R/W	0-50 A, step: 1 A 50 A		
A.6.3.5.3	[5-07]	Amp. limits for DI	Limit DI3	R/W	0-50 A, step: 1 A 50 A		
A.6.3.5.4	[5-08]	Amp. limits for DI	Limit DI4	R/W	0-50 A, step: 1 A 50 A		
A.6.3.6.1	[5-09]	kW limits for DI	Limit DI1	R/W	0-20 kW, step: 0.5 kW 20 kW		
A.6.3.6.2	[5-0A]	kW limits for DI	Limit DI2	R/W	0-20 kW, step: 0.5 kW 20 kW		
A.6.3.6.3	[5-0B]	kW limits for DI	Limit DI3	R/W	0-20 kW, step: 0.5 kW 20 kW		
A.6.3.6.4	[5-0C]	kW limits for DI	Limit DI4	R/W	0-20 kW, step: 0.5 kW 20 kW		
A.6.3.7	[4-01]	Priority		R/W	0: None 1: BSH 2: BUH		
└─ Averaging time							
A.6.4	[1-0A]			R/W	0: No averaging 1: 12 hours 2: 24 hours 3: 48 hours 4: 72 hours		
└─ Ext amb. sensor offset							
A.6.5	[2-0B]			R/W	-5-5°C, step: 0.5°C 0°C		
└─ Boiler efficiency							
A.6.A	[7-05]			R/W	0: Very high 1: High 2: Medium 3: Low 4: Very low		
└─ Overview settings							
A.8	[0-00]	Leaving water value for high ambient temp. for LWT add zone heating WD curve.		R/W	[9-05]-min(45,[9-06])°C, step: 1°C 35°C		
A.8	[0-01]	Leaving water value for low ambient temp. for LWT add zone heating WD curve.		R/W	[9-05]-[9-06]°C, step: 1°C 45°C		
A.8	[0-02]	High ambient temp. for LWT add zone heating WD curve.		R/W	10-25°C, step: 1°C 15°C		
A.8	[0-03]	Low ambient temp. for LWT add zone heating WD curve.		R/W	-40-5°C, step: 1°C -10°C		
A.8	[0-04]	Leaving water value for high ambient temp. for LWT add zone cooling WD curve.		R/W	[9-07]-[9-08]°C, step: 1°C 8°C		
A.8	[0-05]	Leaving water value for low ambient temp. for LWT add zone cooling WD curve.		R/W	[9-07]-[9-08]°C, step: 1°C 12°C		
A.8	[0-06]	High ambient temp. for LWT add zone cooling WD curve.		R/W	25-43°C, step: 1°C 35°C		
A.8	[0-07]	Low ambient temp. for LWT add zone cooling WD curve.		R/W	10-25°C, step: 1°C 20°C		
A.8	[0-0B]	Leaving water value for high ambient temp. for DHW WD curve.		R/W	35-[6-0E]°C, step: 1°C 50°C		
A.8	[0-0C]	Leaving water value for low ambient temp. for DHW WD curve.		R/W	45-[6-0E]°C, step: 1°C 60°C		
A.8	[0-0D]	High ambient temp. for DHW WD curve.		R/W	10-25°C, step: 1°C 15°C		
A.8	[0-0E]	Low ambient temp. for DHW WD curve.		R/W	-40-5°C, step: 1°C -10°C		
A.8	[1-00]	Low ambient temp. for LWT main zone heating WD curve.		R/W	-40-5°C, step: 1°C -10°C		
A.8	[1-01]	High ambient temp. for LWT main zone heating WD curve.		R/W	10-25°C, step: 1°C 15°C		
A.8	[1-02]	Leaving water value for low ambient temp. for LWT main zone heating WD curve.		R/W	[9-01]-[9-00], step: 1°C 35°C		
A.8	[1-03]	Leaving water value for high ambient temp. for LWT main zone heating WD curve.		R/W	[9-01]-min(45,[9-00])°C, step: 1°C 25°C		
A.8	[1-04]	Weather dependent cooling of the main leaving water temperature zone.		R/W	0: Disabled 1: Enabled		
A.8	[1-05]	Weather dependent cooling of the additional leaving water temperature zone		R/W	0: Disabled 1: Enabled		
A.8	[1-06]	Low ambient temp. for LWT main zone cooling WD curve.		R/W	10-25°C, step: 1°C 20°C		
A.8	[1-07]	High ambient temp. for LWT main zone cooling WD curve.		R/W	25-43°C, step: 1°C 35°C		
A.8	[1-08]	Leaving water value for low ambient temp. for LWT main zone cooling WD curve.		R/W	[9-03]-[9-02]°C, step: 1°C 22°C		
A.8	[1-09]	Leaving water value for high ambient temp. for LWT main zone cooling WD curve.		R/W	[9-03]-[9-02]°C, step: 1°C 18°C		
A.8	[1-0A]	What is the averaging time for the outdoor temp?		R/W	0: No averaging 1: 12 hours 2: 24 hours 3: 48 hours 4: 72 hours		
A.8	[1-0B]	--			5		
A.8	[1-0C]	--			5		
A.8	[1-0D]	--			5		
A.8	[1-0E]	--			5		
A.8	[2-00]	When should the disinfection function be executed?		R/W	0: Each day 1: Monday 2: Tuesday 3: Wednesday 4: Thursday 5: Friday 6: Saturday 7: Sunday		

(*1) *HB*_*2) *HV*_
 (*3) *3V_*4) *9W_
 (*5) *04/08*_
 (*6) *11/16*

(#) Setting is not applicable for this unit.

4P383508-1 - 2015.01

Field settings table					Installer setting at variance with default value	
Breadcrumb	Field code	Setting name	Range, step	Default value	Date	Value
A.8	[2-01]	Should the disinfection function be executed?	R/W	0: No 1: Yes		
A.8	[2-02]	When should the disinfection function start?	R/W	0~23 hour, step: 1 hour 23		
A.8	[2-03]	What is the disinfection target temperature?	R/W	[E-07]≠1 : 55~80°C, step: 5°C 70°C [E-07]=1 : 60°C 60°C		
A.8	[2-04]	How long must the tank temperature be maintained?	R/W	[E-07]≠1: 5~60 min, step: 5 min 10 min [E-07]=1: 40~60 min, step: 5 min 40 min		
A.8	[2-05]	Room antifrost temperature	R/W	4~16°C, step: 1°C 12°C		
A.8	[2-06]	Room frost protection	R/W	0: Disabled 1: Enabled		
A.8	[2-09]	Adjust the offset on the measured room temperature	R/W	-5~5°C, step: 0,5°C 0°C		
A.8	[2-0A]	Adjust the offset on the measured room temperature	R/W	-5~5°C, step: 0,5°C 0°C		
A.8	[2-0B]	What is the required offset on the measured outdoor temp.?	R/W	-5~5°C, step: 0,5°C 0°C		
A.8	[3-00]	Is auto restart of the unit allowed?	R/W	0: No 1: Yes		
A.8	[3-01]	--		0		
A.8	[3-02]	--		1		
A.8	[3-03]	--		4		
A.8	[3-04]	--		2		
A.8	[3-05]	--		1		
A.8	[3-06]	What is the maximum desired room temperature in heating?	R/W	18~30°C, step: A.3.2.4 30°C		
A.8	[3-07]	What is the minimum desired room temperature in heating?	R/W	12~18°C, step: A.3.2.4 12°C		
A.8	[3-08]	What is the maximum desired room temperature in cooling?	R/W	25~35°C, step: A.3.2.4 35°C		
A.8	[3-09]	What is the minimum desired room temperature in cooling?	R/W	15~25°C, step: A.3.2.4 15°C		
A.8	[4-00]	What is the BUH operation mode?	R/W	0: Disabled 1: Enabled 2: Only DHW		
A.8	[4-01]	Which electric heater has priority?	R/W	0: None 1: BSH 2: BUH		
A.8	[4-02]	Below which outdoor temperature is heating allowed?	R/W	14~35°C, step: 1°C 25°C (*5) 14~35°C, step: 1°C 35°C (*6)		
A.8	[4-03]	Operation permission of the booster heater.	R/W	0: Limited 1: No limit 2: Most optimum 3: Optimum		
A.8	[4-04]	--		2		
A.8	[4-05]	--		0		
A.8	[4-06]	-- (Do not change this value)		0/1		
A.8	[4-07]	Enable the second step of the backup heater?	R/W	0: No 1: Yes		
A.8	[4-08]	Which power limitation mode is required on the system?	R/W	0: No limitation 1: Continuous 2: Digital inputs		
A.8	[4-09]	Which power limitation type is required?	R/W	0: Current 1: Power		
A.8	[4-0A]	--		0		
A.8	[4-0B]	Automatic cooling/heating changeover hysteresis.	R/W	1~10°C, step: 0,5°C 1°C		
A.8	[4-0D]	Automatic cooling/heating changeover offset.	R/W	1~10°C, step: 0,5°C 3°C		
A.8	[5-00]	Is backup heater operation allowed above equilibrium temperature during space heating operation?	R/W	0: Allowed 1: Not allowed		
A.8	[5-01]	What is the equilibrium temperature for the building?	R/W	-15~35°C, step: 1°C 0°C		
A.8	[5-02]	Space heating priority.	R/W	0: Disabled [E-07]≠1 1: Enabled [E-07]=1		
A.8	[5-03]	Space heating priority temperature.	R/W	-15~35°C, step: 1°C 0°C		
A.8	[5-04]	Set point correction for domestic hot water temperature.	R/W	0~20°C, step: 1°C 10°C		
A.8	[5-05]	What is the requested limit for DI1?	R/W	0~50 A, step: 1 A 50 A		
A.8	[5-06]	What is the requested limit for DI2?	R/W	0~50 A, step: 1 A 50 A		
A.8	[5-07]	What is the requested limit for DI3?	R/W	0~50 A, step: 1 A 50 A		
A.8	[5-08]	What is the requested limit for DI4?	R/W	0~50 A, step: 1 A 50 A		
A.8	[5-09]	What is the requested limit for DI1?	R/W	0~20 kW, step: 0,5 kW 20 kW		
A.8	[5-0A]	What is the requested limit for DI2?	R/W	0~20 kW, step: 0,5 kW 20 kW		
A.8	[5-0B]	What is the requested limit for DI3?	R/W	0~20 kW, step: 0,5 kW 20 kW		
A.8	[5-0C]	What is the requested limit for DI4?	R/W	0~20 kW, step: 0,5 kW 20 kW		
A.8	[5-0D]	What type of backup heater installation is used?	R/W	0: 1P,(1/2) 1: 1P,(1/1+2) 2: 3P,(1/2) 3: 3P,(1/1+2) (*3) 4: 3PN,(1/2) 5: 3PN,(1/1+2) (*4)		
A.8	[5-0E]	--		1		
A.8	[6-00]	The temperature difference determining the heat pump ON temperature.	R/W	2~20°C, step: 1°C 2°C		
A.8	[6-01]	The temperature difference determining the heat pump OFF temperature.	R/W	0~10°C, step: 1°C 2°C		

(*1) *HB* (*2) *HV*
 (*3) *3V* (*4) *9W*
 (*5) *04/08*
 (*6) *11/16*

Field settings table					Installer setting at variance with default value	
Breadcrumb	Field code	Setting name	Range, step	Default value	Date	Value
A.8	[6-02]	What is the capacity of the booster heater?	R/W	0~10kW, step: 0,2kW 0kW		
A.8	[6-03]	What is the capacity of the backup heater step 1?	R/W	0~10kW, step: 0,2kW 3kW		
A.8	[6-04]	What is the capacity of the backup heater step 2?	R/W	0~10kW, step: 0,2kW 0kW (*3) 6kW (*4)		
A.8	[6-05]	--		0		
A.8	[6-06]	--		0		
A.8	[6-07]	What is the capacity of the bottom plate heater?	R/W	0~200W, step: 10W 0W		
A.8	[6-08]	What is the hysteresis to be used in reheat mode?	R/W	2~20°C, step: 1°C 10°C		
A.8	[6-09]	--		0		
A.8	[6-0A]	What is the desired comfort storage temperature?	R/W	30-[6-0E]°C, step: 1°C 60°C		
A.8	[6-0B]	What is the desired eco storage temperature?	R/W	30~min(50, [6-0E])°C, step: 1°C 45°C		
A.8	[6-0C]	What is the desired reheat temperature?	R/W	30~min(50, [6-0E])°C, step: 1°C 45°C		
A.8	[6-0D]	What is the desired DHW production type?	R/W	0: Reheat only 1: Reheat + sched. 2: Scheduled only		
A.8	[6-0E]	What is the maximum temperature setpoint?	R/W	[E-07]#1 : 40~80°C, step: 1°C 60°C [E-07]=1 : 40~60°C, step: 1°C 60°C		
A.8	[7-00]	Domestic hot water booster heater overshoot temperature.	R/W	0~4°C, step: 1°C 0°C		
A.8	[7-01]	Domestic hot water booster heater hysteresis.	R/W	2~40°C, step: 1°C 2°C		
A.8	[7-02]	How many leaving water temperature zones are there?	R/W	0: 1 LWT zone 1: 2 LWT zones		
A.8	[7-03]	--		2,5		
A.8	[7-04]	--		0		
A.8	[7-05]	Boiler efficiency	R/W	0: Very high 1: High 2: Medium 3: Low 4: Very low		
A.8	[8-00]	--		1 min		
A.8	[8-01]	Maximum running time for domestic hot water operation.	R/W	5~95 min, step: 5 min 30 min		
A.8	[8-02]	Anti-recycling time.	R/W	0~10 hour, step: 0,5 hour 0,5 hour [E-07]=1 3 hour [E-07]#1		
A.8	[8-03]	Booster heater delay timer.	R/W	20~95 min, step: 5 min 50 min		
A.8	[8-04]	Additional running time for the maximum running time.	R/W	0~95 min, step: 5 min 95 min		
A.8	[8-05]	Allow modulation of the LWT to control the room temp?	R/W	0: No 1: Yes		
A.8	[8-06]	Leaving water temperature maximum modulation.	R/W	0~10°C, step: 1°C 3°C		
A.8	[8-07]	What is the desired comfort main LWT in cooling?	R/W	[9-03]~[9-02], step: 1°C 18°C		
A.8	[8-08]	What is the desired eco main LWT in cooling?	R/W	[9-03]~[9-02], step: 1°C 20°C		
A.8	[8-09]	What is the desired comfort main LWT in heating?	R/W	[9-01]~[9-00], step: 1°C 35°C		
A.8	[8-0A]	What is the desired eco main LWT in heating?	R/W	[9-01]~[9-00], step: 1°C 33°C		
A.8	[8-0B]	--		13		
A.8	[8-0C]	--		10		
A.8	[8-0D]	--		16		
A.8	[9-00]	What is the maximum desired LWT for main zone in heating?	R/W	37~depending on outdoor unit, step: 1°C 55°C		
A.8	[9-01]	What is the minimum desired LWT for main zone in heating?	R/W	15~37°C, step: 1°C 25°C		
A.8	[9-02]	What is the maximum desired LWT for main zone in cooling?	R/W	18~22°C, step: 1°C 22°C		
A.8	[9-03]	What is the minimum desired LWT for main zone in cooling?	R/W	5~18°C, step: 1°C 5°C		
A.8	[9-04]	Leaving water temperature overshoot temperature.	R/W	1~4°C, step: 1°C 1°C		
A.8	[9-05]	What is the minimum desired LWT for add. zone in heating?	R/W	15~37°C, step: 1°C 25°C		
A.8	[9-06]	What is the maximum desired LWT for add. zone in heating?	R/W	37~depending on outdoor unit, step: 1°C 55°C		
A.8	[9-07]	What is the minimum desired LWT for add. zone in cooling?	R/W	5~18°C, step: 1°C 5°C		
A.8	[9-08]	What is the maximum desired LWT for add. zone in cooling?	R/W	18~22°C, step: 1°C 22°C		
A.8	[9-09]	What is the desired delta T in heating?	R/W	3~10°C, step: 1°C 5°C		
A.8	[9-0A]	What is the desired delta T in cooling?	R/W	3~10°C, step: 1°C 5°C		
A.8	[9-0B]	What emitter type is connected to the main LWT zone?	R/W	0: Quick 1: Slow		
A.8	[9-0C]	Room temperature hysteresis.	R/W	1~6°C, step: 0,5°C 1°C		
A.8	[9-0D]	Pump speed limitation	R/W	0~8, step:1 0 : 100% 1~4 : 80~50% 5~8 : 80~50% 6		
A.8	[9-0E]	--		6		
A.8	[A-00]	--		0		
A.8	[A-01]	--		0 (*5) 3 (*6)		

(*1) *HB*_*2) *HV*_*

(*3) *3V_*4) *9W_*

(*5) *04/08*_*

(*6) *11/16*_*

(#) Setting is not applicable for this unit.

4P383508-1 - 2015.01

Field settings table					Installer setting at variance with default value	
Breadcrumb	Field code	Setting name	Range, step	Default value	Date	Value
A.8	[A-02]	--		0 (*5) 1 (*6)		
A.8	[A-03]	--		0		
A.8	[A-04]	--		0		
A.8	[B-00]	--		0		
A.8	[B-01]	--		0		
A.8	[B-02]	--		0		
A.8	[B-03]	--		0		
A.8	[B-04]	--		0		
A.8	[C-00]	Domestic heating water priority.	R/W	0: Solar priority 1: Heat pump priority		
A.8	[C-01]	--		0		
A.8	[C-02]	Is an external backup heat source connected?	R/W	0: No 1: Bivalent 2: - 3: -		
A.8	[C-03]	Bivalent activation temperature.	R/W	-25~25°C, step: 1°C 0°C		
A.8	[C-04]	Bivalent hysteresis temperature.	R/W	2~10°C, step: 1°C 3°C		
A.8	[C-05]	What is the thermo request contact type for the main zone?	R/W	1: Thermo ON/OFF 2: C/H request		
A.8	[C-06]	What is the thermo request contact type for the add. zone?	R/W	0: - 1: Thermo ON/OFF 2: C/H request		
A.8	[C-07]	What is the unit control method in space operation?	R/W	0: LWT control 1: Ext RT control 2: RT control		
A.8	[C-08]	Which type of external sensor is installed?	R/W	0: No 1: Outdoor sensor 2: Room sensor		
A.8	[C-09]	What is the required alarm output contact type?	R/W	0: Normally open 1: Normally closed		
A.8	[C-0A]	--		0		
A.8	[C-0C]	High electricity price decimal (Do not use)	R/W	0~7 0		
A.8	[C-0D]	Medium electricity price decimal (Do not use)	R/W	0~7 0		
A.8	[C-0E]	Low electricity price decimal (Do not use)	R/W	0~7 0		
A.8	[D-00]	Which heaters are permitted if prefer. kWh rate PS is cut?	R/W	0: None 1: BSH only 2: BUH only 3: All heaters		
A.8	[D-01]	Contact type of preferential kWh rate PS installation?	R/W	0: No 1: Active open 2: Active closed		
A.8	[D-02]	Which type of DHW pump is installed?	R/W	0: No 1: Secondary rtm 2: Disinf. shunt		
A.8	[D-03]	Leaving water temperature compensation around 0°C.	R/W	0: Disabled 1: Enabled, shift 2°C (from -2 to 2°C) 2: Enabled, shift 4°C (from -2 to 2°C) 3: Enabled, shift 2°C (from -4 to 4°C) 4: Enabled, shift 4°C (from -4 to 4°C)		
A.8	[D-04]	Is a demand PCB connected?	R/W	0: No 1: Pwr consmp ctrl		
A.8	[D-05]	Is the pump allowed to run if prefer. kWh rate PS is cut?	R/W	0: Forced off 1: As normal		
A.8	[D-07]	Is a solar kit connected?	R/W	0: No 1: Yes		
A.8	[D-08]	Is an external kWh meter used for power measurement?	R/W	0: No 1: 0,1 pulse/kWh 2: 1 pulse/kWh 3: 10 pulse/kWh 4: 100 pulse/kWh 5: 1000 pulse/kWh		
A.8	[D-09]	Is an external kWh meter used for power measurement?	R/W	0: No 1: 0,1 pulse/kWh 2: 1 pulse/kWh 3: 10 pulse/kWh 4: 100 pulse/kWh 5: 1000 pulse/kWh		
A.8	[D-0A]	--		0		
A.8	[D-0B]	--		2		
A.8	[D-0C]	What is the high electricity price (Do not use)	R/W	0~49 0		
A.8	[D-0D]	What is the medium electricity price (Do not use)	R/W	0~49 0		
A.8	[D-0E]	What is the low electricity price (Do not use)	R/W	0~49 0		
A.8	[E-00]	Which type of unit is installed?	R/O	0~5 0: LT split		
A.8	[E-01]	Which type of compressor is installed?	R/O	0: 8 1: 16		
A.8	[E-02]	What is the indoor unit software type?	R/O	0: Type 1 1: Type 2		
A.8	[E-03]	What is the number of backup heater steps?	R/O	0: No BUH 1: 1 step 2: 2 steps		
A.8	[E-04]	Is the power saving function available on the outdoor unit?	R/O	0: No 1: Yes		
A.8	[E-05]	Can the system prepare domestic hot water?	R/W	0: No (*1) 1: Yes (*2)		
A.8	[E-06]	Is a DHW tank installed in the system?	R/O	0: No 1: Yes		
A.8	[E-07]	What kind of DHW tank is installed?	R/W	0~6 0: Type 1 (*1) 1: Type 2 (*2)		
A.8	[E-08]	Power saving function for outdoor unit.	R/W	0: Disabled (*6) 1: Enabled (*5)		
A.8	[E-09]	--		0		
A.8	[E-0A]	--		0		

(*1) *HB* (*2) *HV*
 (*3) *3V* (*4) *9W*
 (*5) *04/08*
 (*6) *11/16*

Field settings table				Installer setting at variance with default value		
Breadcrumb	Field code	Setting name	Range, step	Default value	Date	Value
A.8	[E-0B]	Is a bi-zone kit installed?	R/O	0 (#)		
A.8	[E-0C]	--		0		
A.8	[F-00]	Pump operation allowed outside range.	R/W	0: Disabled 1: Enabled		
A.8	[F-01]	Above which outdoor temperature is cooling allowed?	R/W	10~35°C, step: 1°C 20°C		
A.8	[F-02]	Bottom plate heater ON temperature.	R/W	3~10°C, step: 1°C 3°C		
A.8	[F-03]	Bottom plate heater hysteresis.	R/W	2~5°C, step: 1°C 5°C		
A.8	[F-04]	Is a bottom plate heater connected?	R/W	0: No 1: Yes		
A.8	[F-05]	--		0		
A.8	[F-06]	--		0		
A.8	[F-09]	Pump operation during flow abnormality.	R/W	0: Disabled 1: Enabled		
A.8	[F-0A]	--		0		
A.8	[F-0B]	Close shut-off valve during thermo OFF?	R/W	0: No 1: Yes		
A.8	[F-0C]	Close shut-off valve during cooling?	R/W	0: No 1: Yes		
A.8	[F-0D]	What is the pump operation mode?	R/W	0: Continuous 1: Sample 2: Request		

(*1) *HB*_*2) *HV*_
 (*3) *3V_*4) *9W_
 (*5) *04/08*_
 (*6) *11/16*

(#) Setting is not applicable for this unit.

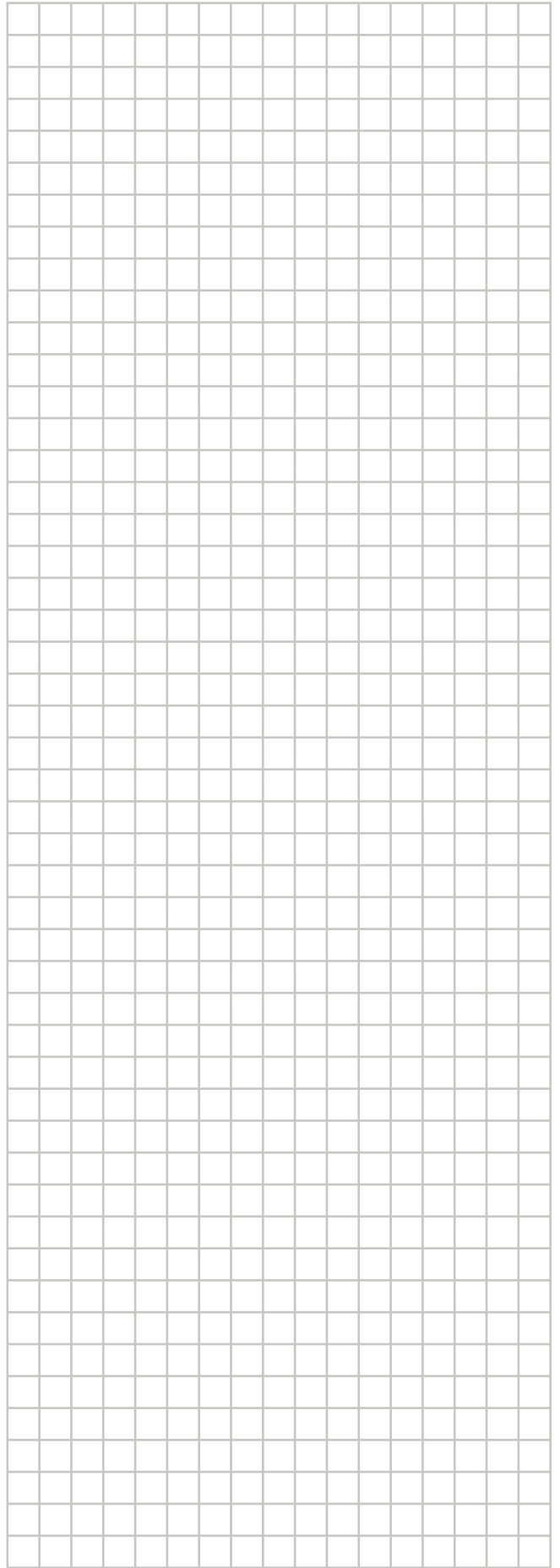
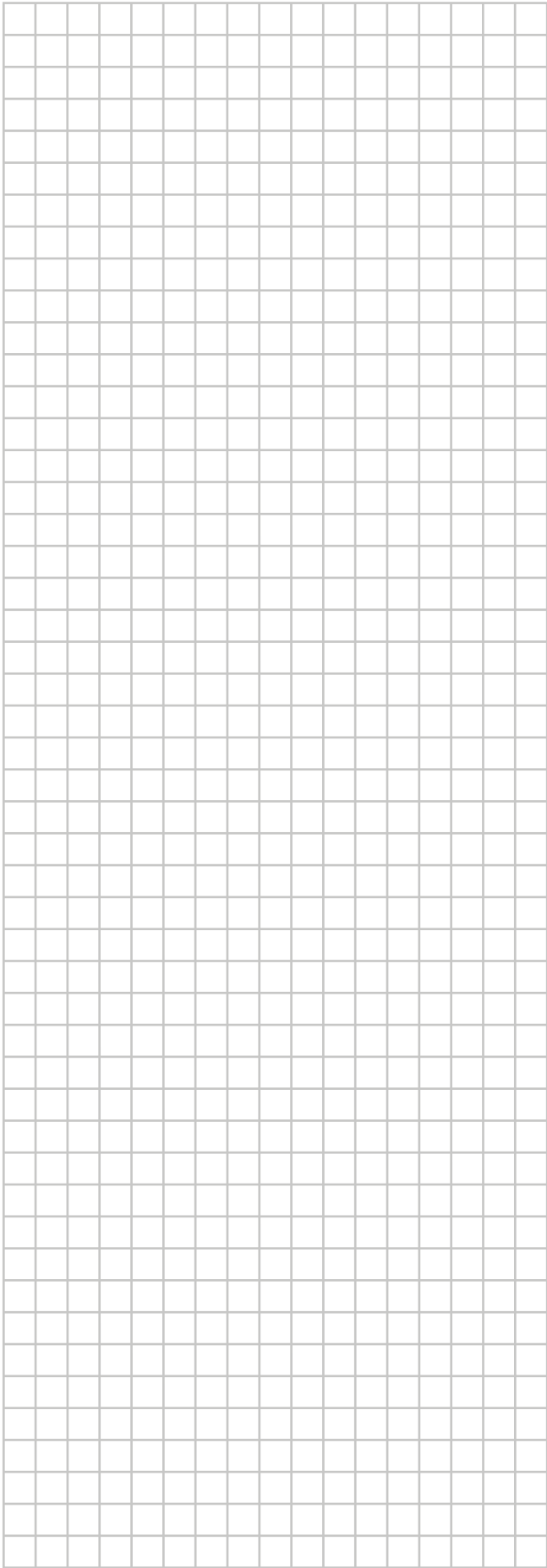

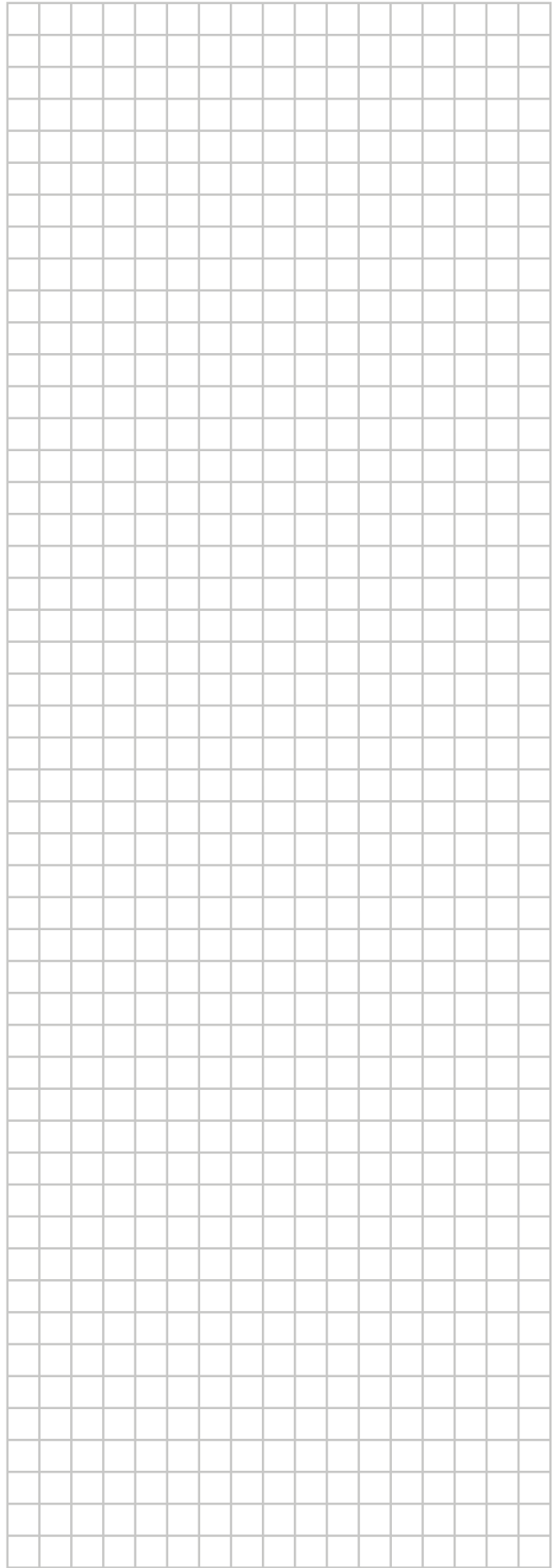
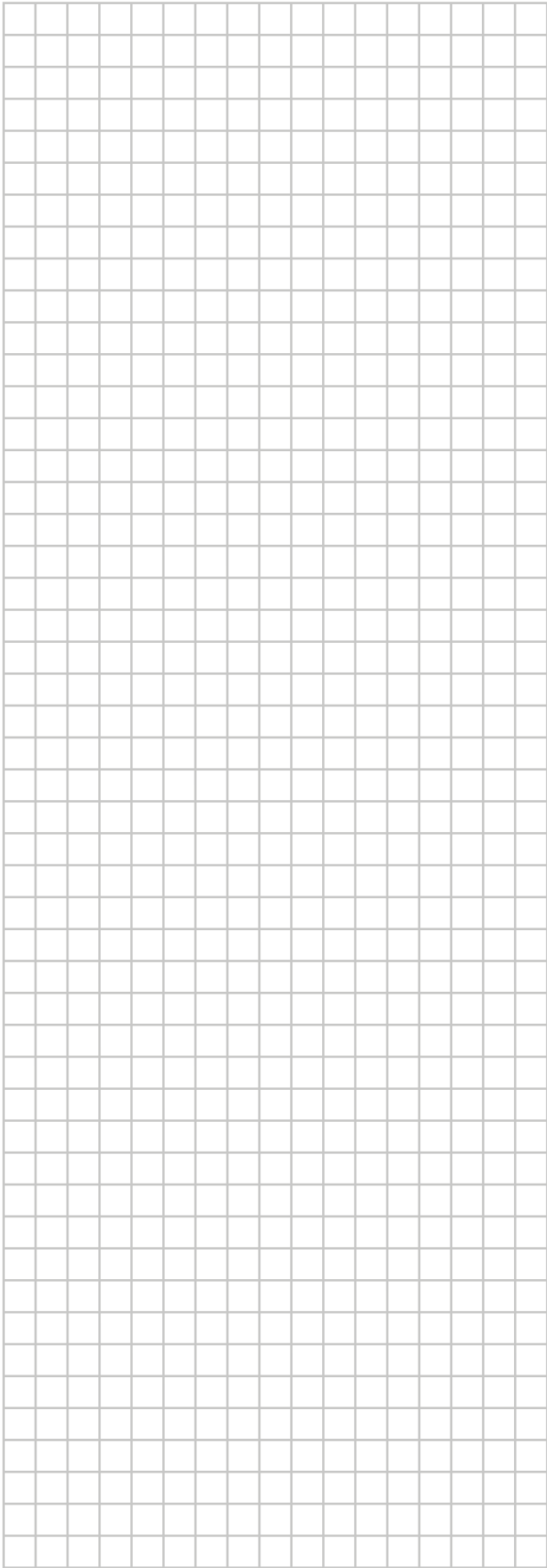

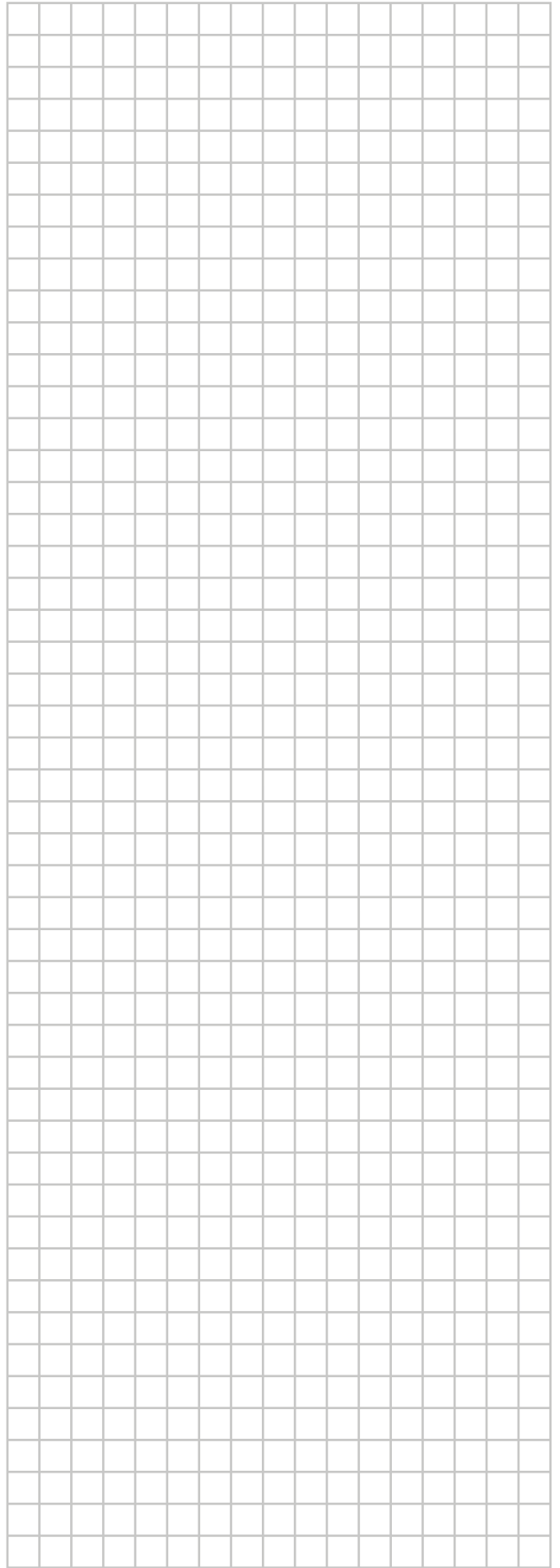
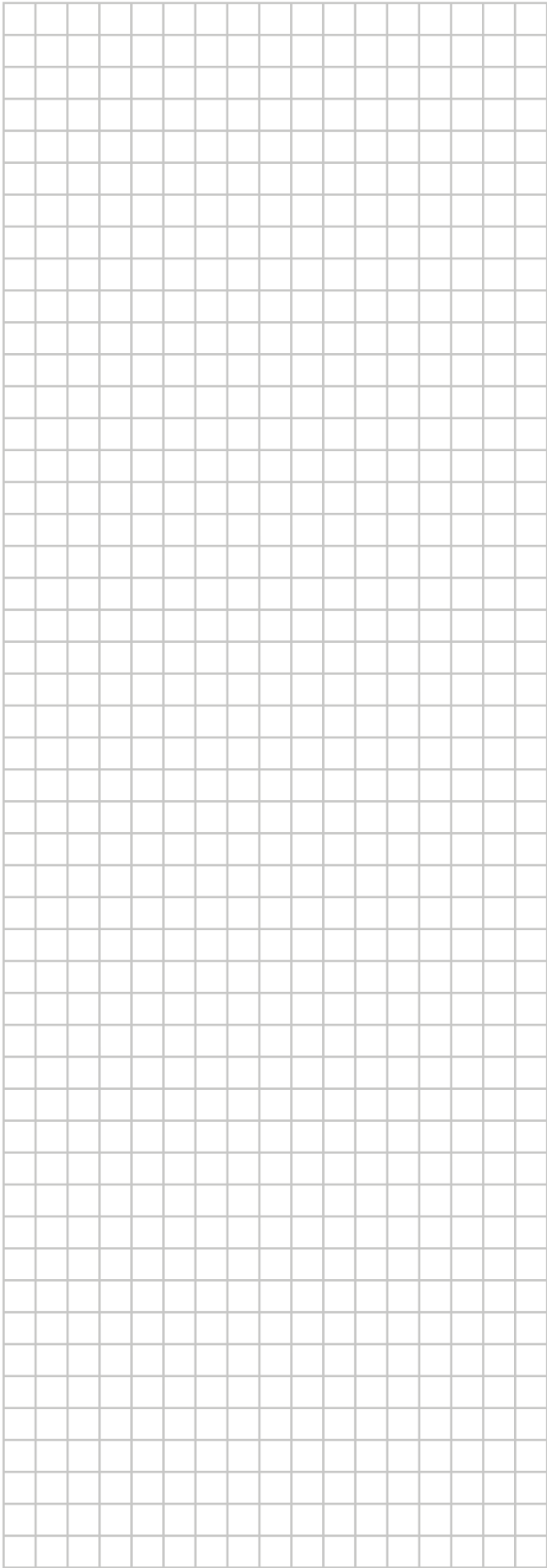

ERC

Copyright 2015 Daikin